

# Jet Towel Hand dryer

**MODEL**

<b>JT-S2AP-W-NE</b>	Heater Model
<b>JT-S2AP-S-NE</b>	
<b>JT-S2A-W-NE</b>	Heater-less Model
Unit colour	-W (White) -S (Silver)

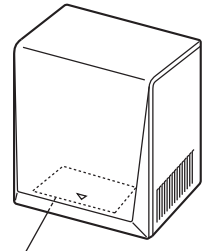

Location of Model Name display  
Location of power supply voltage display

Single-phase 220 – 240V AC

## INSTALLATION MANUAL

## For Dealers and Installers

Read the manual thoroughly before beginning installation to ensure the unit is installed safely and correctly. Local installation standards should be obeyed and installation should be performed by the dealer or a qualified professional.





The "INSTRUCTION MANUAL" is for the customer. Be sure to hand it to the customer.



**INDEX**

Safety Precautions .....	2
■ Checking the installation environment .....	3
Parts to be installed .....	4
■ Main unit .....	4
■ Accessories .....	5
■ Required items .....	5
Use environment .....	6
■ Required space for installation .....	6
■ Suitable walls .....	6
■ Installation position .....	6
Installation procedure .....	7
■ Fixing the installation panel .....	8
■ Fixing the base .....	8
■ Removing the terminal cover .....	9
■ Wiring .....	9
■ Checking the setting .....	11
■ Attaching the front cover .....	12
Checking after installation .....	13
■ Removing the front cover after installation .....	13
Test Run .....	14
Instructions given to customer .....	14

# Safety Precautions

•The dangers arising from improper handling and the extents of the dangers are classified and explained as shown below.

 <b>Warning</b> The following may lead to death or serious personal injury if handled incorrectly.		
 <p>Prohibited</p>	<ul style="list-style-type: none"> <li>•Do not install in locations where they may be leakages of combustible gas. This may cause fires.</li> <li>•Do not install in locations where salt damage may occur or where corrosive, neutral or reductive gases are present. This may cause malfunctions.</li> <li>•Do not scratch, damage, process, excessively bend, pull, twist or bundle the power cable. Please also refrain from placing heavy objects onto it or trapping it. Failure to do so may damage the power cable, causing fires or electric shocks.</li> </ul>	 <p>Important ! Follow instructions</p> <ul style="list-style-type: none"> <li>•Wiring work is to be done by a certified electrical worker in accordance with technical standards for electrical equipment and internal wiring regulations. Incorrect wiring work may cause electric shocks or fires.</li> <li>•Use single-phase 220 – 240V AC power. Using the incorrect power supply may cause fires, electric shocks or malfunctions.</li> <li>•Use exclusive wiring for the power source. Using this unit with other devices on a branch socket may cause abnormal heat, which may cause fires.</li> <li>•Be sure to install a ground-fault circuit interrupter. Failure to do so may result in electric shocks.</li> <li>•The unit shall be installed in accordance with national wiring regulations.</li> <li>•A means for disconnection must be incorporated in the fixed wiring in accordance with wiring rules.</li> </ul>
 <p>Do not disassemble</p>	<ul style="list-style-type: none"> <li>•Do not attempt any disassembly or modification of the unit that is not expressly stated in this manual. Doing so may result in fires, electric shocks or injuries.</li> </ul>	
 <p>Do not use in the baths/shower room</p>	<ul style="list-style-type: none"> <li>•Do not use in a hot location such as a shower room, where condensation may form on the unit or where water may splash directly onto the unit. This may cause electric shocks or malfunctions.</li> </ul>	

 <b>Caution</b> The following may lead to minor injuries or damage to property if the unit is handled incorrectly.		
 <p>Prohibited</p>	<ul style="list-style-type: none"> <li>•Do not install when the unit (power cable) is electrified. Doing so may result in electric shocks.</li> </ul>	 <p>Important ! Follow instructions</p> <ul style="list-style-type: none"> <li>•Install securely in a location strong enough to support the weight of the unit. Injuries may be caused if the unit falls off the wall.</li> <li>•Wear gloves when installing the unit. Not doing so may result in injuries.</li> </ul>

## Safety Precautions (continued)



### Warning

- **Single-phase 220 – 240V AC power is used.**

Using the incorrect power supply may cause fires, electric shocks or malfunctions.

#### ■ Checking the installation environment

**Do not install the unit in the following types of locations.**

(This may cause malfunctions.)

- **Outdoors**
- **Locations where the temperature could be lower than 0°C.**
- **Locations where there is a lot of dust.**
- **Locations where the temperature could be higher than 40°C.**
- **Locations where there is a lot of condensation.**
- **Locations where salt damage may occur.**
- **Locations where the unit is in direct or strong sunlight** (may cause the sensor to malfunction).
- **In vehicles** (including ships and airplanes)
- **Locations where corrosive, neutral or reductive gasses are present.**  
(This may shorten the working life of the unit and/or cause malfunctions.)
- **Near food or tableware**
- **Locations where the unit may come into direct contact with water.**
- **Kitchens**  
(Where there is a risk of water splashing.)
- **Rooms that have a sterilisation basin, swimming pools and baths.**

# Parts to be installed

■ **Main unit** ※ Shaded areas in the figure indicate antibacterial material (excluding outlet nozzle areas).

## ■ Front

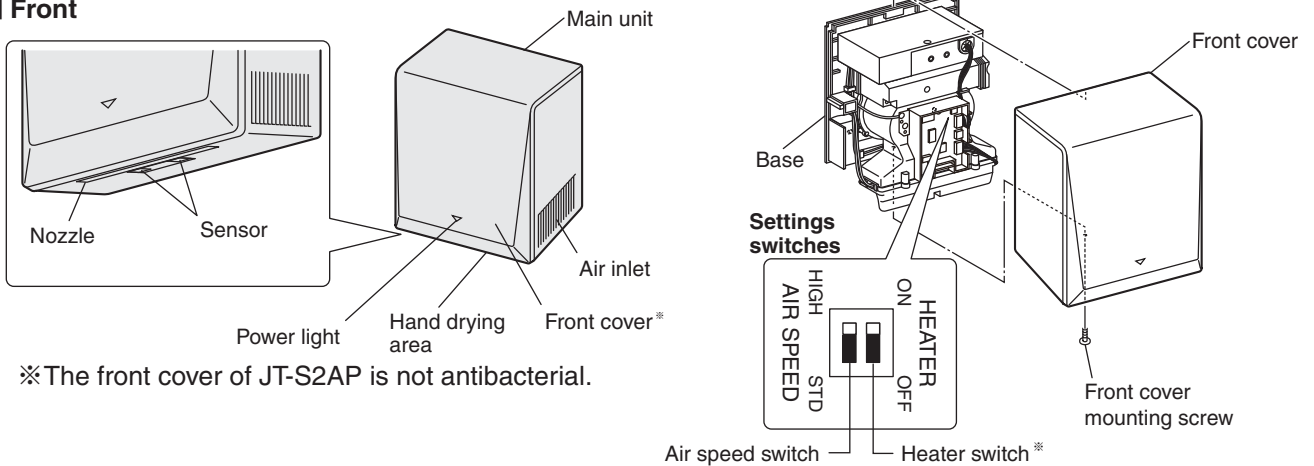

※The front cover of JT-S2AP is not antibacterial.

※JT-S2A does not have the heater switch.

### NOTE

- Prevent scratching on the front cover. Rust may form on the scratched area. (JT-S2AP only)
- Please refer to "**Heater ON/OFF setting**" (Page 11) while turning the heater on/off.
- Please refer to "**Air speed HIGH/STD setting**" (Page 11) while adjusting the air speed.

## ■ Rear

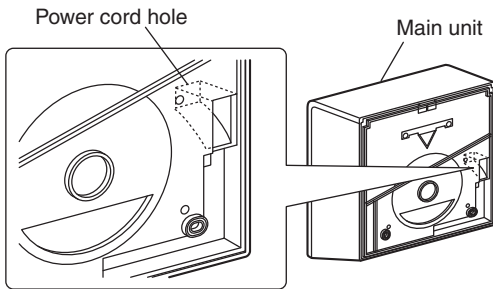

## <External dimensions>

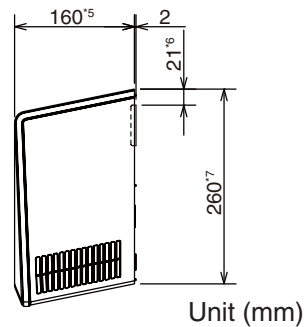
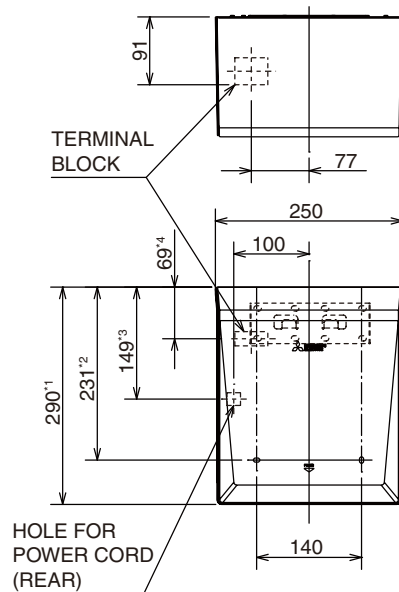

JT-S2A



- \*1: 292
- \*2: 233
- \*3: 151
- \*4: 71
- \*5: 162
- \*6: 23
- \*7: 262

### NOTE

- Refer to "Use environment". (Page 6)

# Parts to be installed (continued)

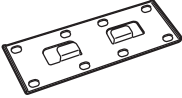
## Accessories

Mounting screws .....6 (5 × 30 Type 1 tapping screws)	Installation panel .....1	Cord clip mounting screw (4 × 14) ..... 1	Cord clip ..... 1
			

## Required items

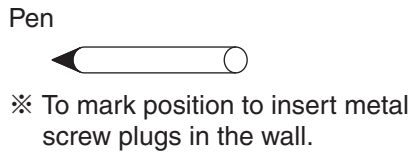
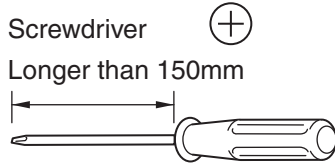

### Prepare if required

Single wire for internal wiring  
 (Cable core: between 1.0mm<sup>2</sup> and 2.5mm<sup>2</sup>)

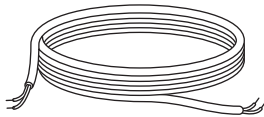

※ Not needed if the internal wiring is complete.

Screw anchor .....6

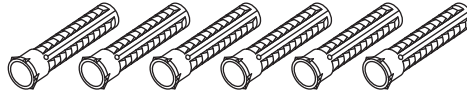

※ Use on concrete walls

Wall reinforcement

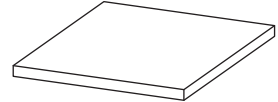

※ Reinforces walls made of materials other than concrete.

# Use environment

## Required space for installation

**Caution** Be sure to secure at least the distances listed in the righthand table from walls, flammable (combustible) materials and so on.

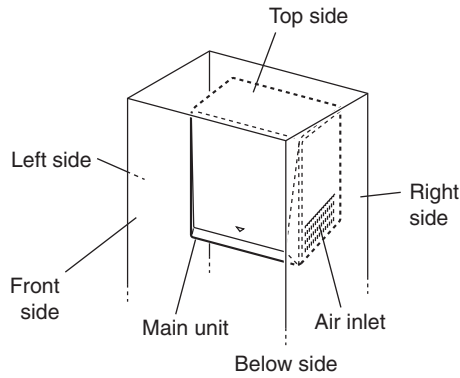

Unit (mm)	
Location	Isolation distance
Above	150
Left	100
Right	100
Front	Open
Below	Open

## Suitable walls

- When installing on a wall, select a wall with a flat and even surface.
- When installing on a concrete wall, use commercially available metal screw plugs.
- Reinforce any walls made with materials other than concrete before installation.

## Installation position

- Refer to "Installation position guide" and "Installation diagram" and install the unit in an easily accessible position.
- If it is installed at a low position, it may become wet when the sink is being washed.
- If water enters the unit, it may cause damage or cause the acoustic materials to absorb water and allow bacteria to grow.
- Do not install the main unit in locations such as those near mirrors or walls.
- This may lead to water drops flying to undesirable areas during the drying of the hands.
- Do not install the main unit in locations such as those near food or eating utensils.
- This may lead to water drops flying to undesirable areas during the drying of the hands.
- Avoid locations where people or doors might bump into the unit.

### Installation position guide

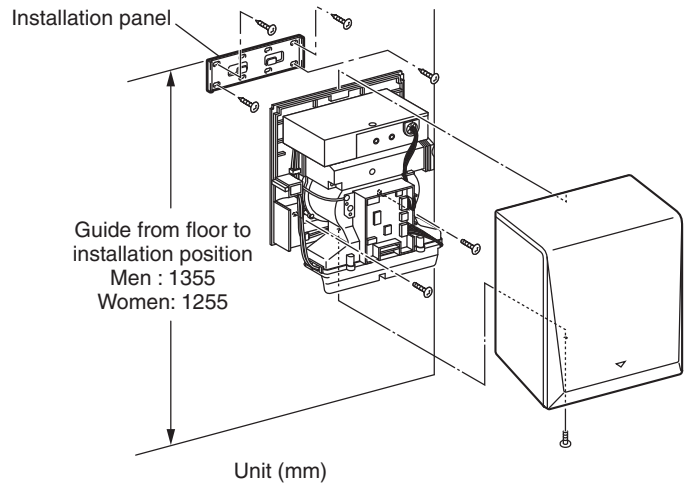

### Installation diagram

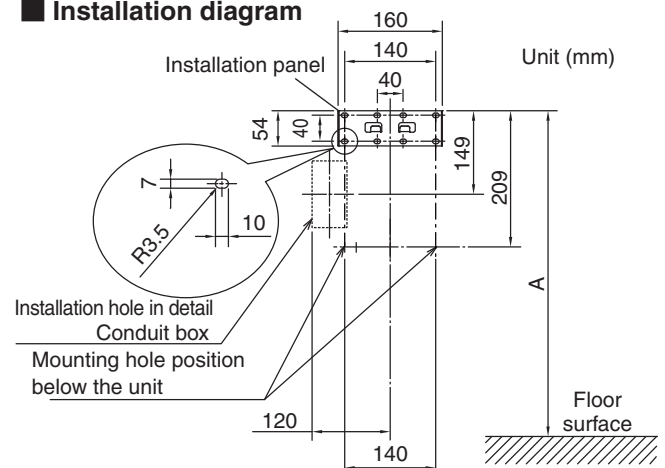

### Recommended A measurement during installation

Unit (mm)		
Space below the unit		A
When there are no objects below	Men	1355
	Women	1255

# Installation procedure

## For confirmation

- Single-phase 220 – 240V AC** power is being used (using the incorrect power supply may cause fires, electric shocks or malfunctions).
- The ground fault circuit interrupter is attached (not attaching a ground fault circuit interrupter may result in electric shocks).
- The power cable has a 1.0 mm<sup>2</sup> to 2.5 mm<sup>2</sup> core.

## Warning

### • **Single-phase 220 – 240V AC** power is used.

Using the incorrect power supply may cause fires, electric shocks or malfunctions.

## Caution

### • Do not install when the unit (power cable) is electrified.

Doing so may result in electric shocks.

1

### Confirm that the severing of wires during fixed wiring work is in accordance with wiring regulations.

- Follow the illustration on the right for the internal wiring.
- The power cable forces out the main unit and does not allow proper installation if the conduit box is not used.

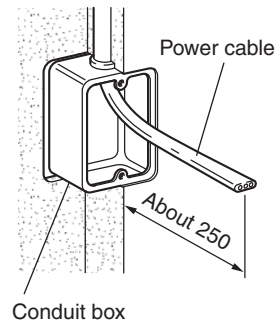

Unit (mm)

#### NOTE

- Prevent scratching on the front cover. Rust may form on the scratched area. (JT-S2AP only)

### 1. Remove the front cover mounting screw (1).

### 2. Disengage the tab of the upper part of the front cover.

- ① Attach the installation panel to the hook of the main unit
- ② Hold down the installation panel and put your hand on the claw hook to remove the front cover

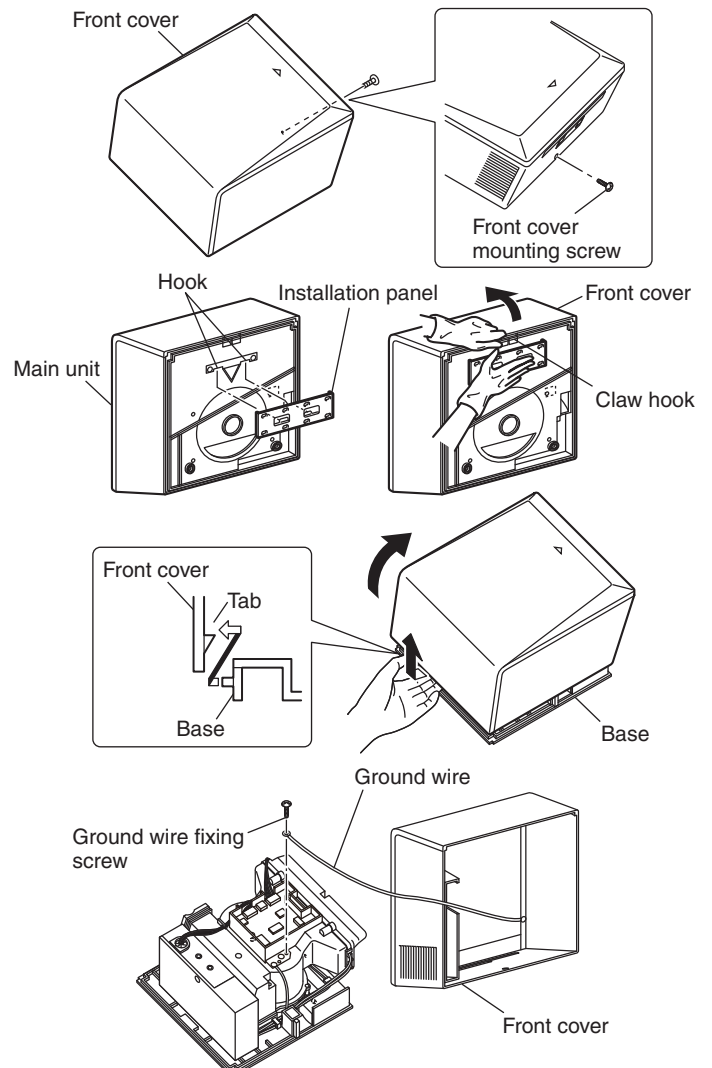

### 3. Remove the ground wire fixing screw (1) from the base and remove the front cover. (JT-S2AP only)

# Installation procedure (continued)

3

## ■ Fixing the installation panel

Fix the installation panel onto the wall with 4 accessory mounting screws (5 × 30).

- The "Installation position guide" illustrated on the right is recommended.
- When installing on a wall, select a wall with a flat and even surface.
- When installing on a concrete wall, use commercially available metal screw plugs.
- Reinforce any walls made with materials other than concrete before installation.

### Recommended A measurement during installation

		Unit (mm)
Space below the unit		A
When there are no objects below	Men	1355
	Women	1255

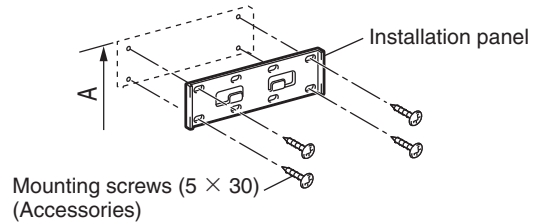

## ■ Installation position guide

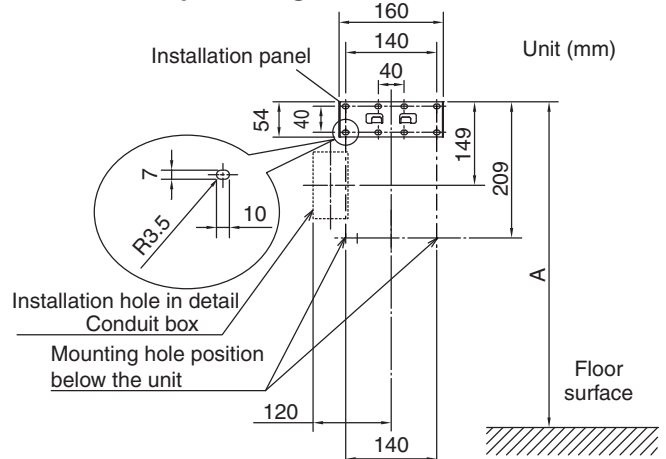

4

## ■ Fixing the base

1. Push the power cable for exclusive wiring through the power cord hole at the rear of the base.
2. Engage the base with the 2 hooks on the installation panel.
3. Check that the 2 hooks on the front cover are hooked in the base.
4. Check that the power cable is not trapped behind the base.
5. While lightly pressing the base against the wall, fix it with the accessory mounting screws (5x30) (2).

- To install the unit on a concrete wall, before fixing the base, embed commercially available wall plugs into the wall with the following procedure.

- ① Temporarily put the base on the installation panel.
- ② Mark the position of the hole in the wall through the mounting screw hole with a pen.
- ③ Remove the base and embed the commercially available wall plugs into the marked positions.

- Reinforce any walls made with materials other than concrete before installation.

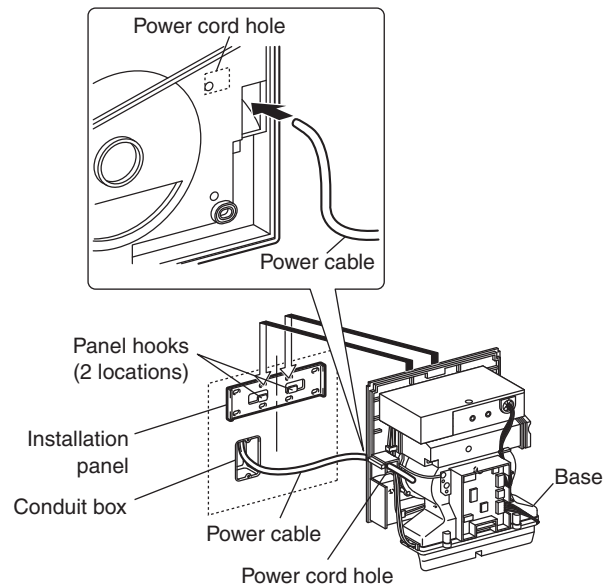

### Plug positioning

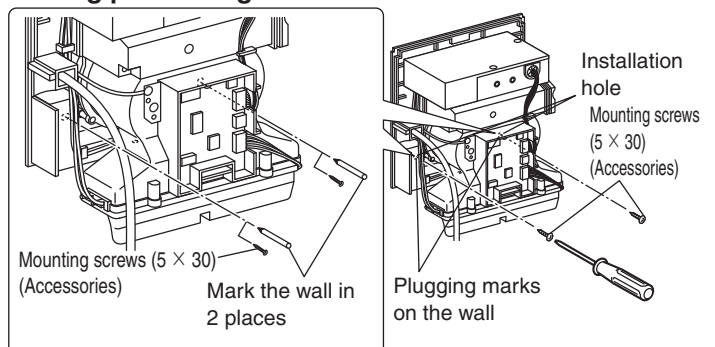



# Installation procedure (continued)

5

## ■ Removing the terminal cover

1. Remove the terminal cover mounting screw (1) and remove the terminal cover.

※ Be careful not to lose the cord bushing.

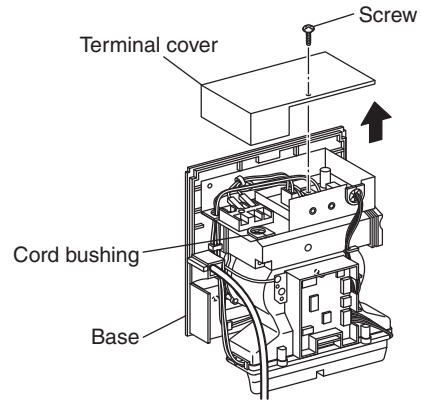

## ■ Wiring

### ⚠ Warning

- **Single-phase 220 – 240V AC** power is used.

Using the incorrect power supply may cause fires, electric shocks or malfunctions.

### ⚠ Caution

- Make sure that the main unit does not fall as the base is not attached to the wall with screws. Injuries may be caused if the unit falls off the wall.

## JT-S2A

Connect the power cable to the terminal block. (Ensure the polarity)

1. Remove 12mm (single wire) or 8mm (stranded wire) of wire sheath from the end.
2. Fix the power cable to the terminal block.
  - When stranded wire is used for the power cable, attach an insulated ring tongue terminal using an appropriate tool.
  - Proper torque is 1.2N·m
3. Check that the power cable is securely fixed to the terminal block.
4. Use the cord clip mounting screw hole to fix the power cable with the accessory cord clip and mounting screw (4 × 14).
  - Proper torque is 1.2N·m
  - Fix it where the external wire sheath of the power cable is when it is fixed in the cord clip mounting position.

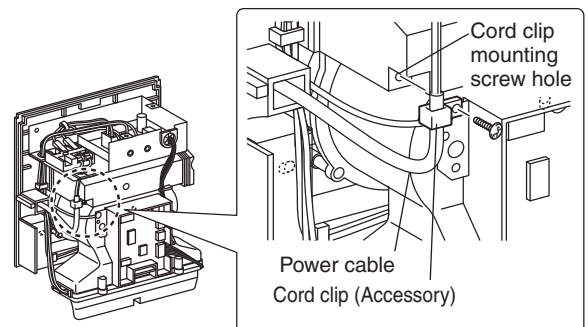
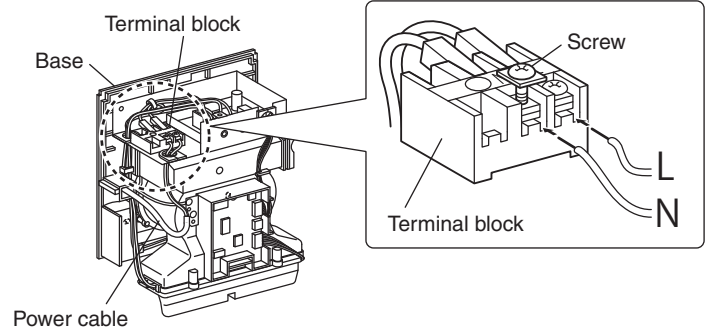
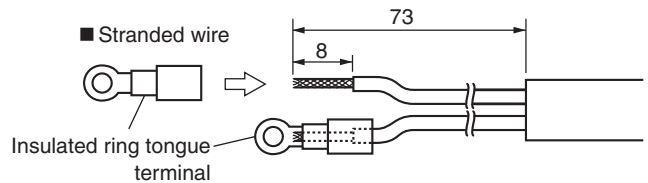
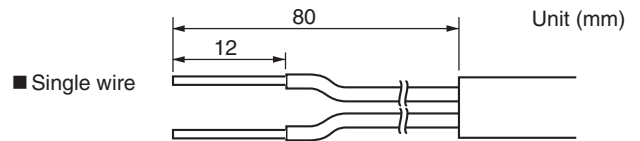

6

# Installation procedure (continued)



## Warning

- **Single-phase 220 – 240V AC power is used.**

Using the incorrect power supply may cause fires, electric shocks or malfunctions.



## Caution

- **Make sure that the main unit does not fall as the base is not attached to the wall with screws.** Injuries may be caused if the unit falls off the wall.

## JT-S2AP

Connect the power cable to the terminal block. (Ensure the polarity)

1. Remove 12mm (single wire) or 8mm (stranded wire) of wire sheath from the end.
2. Fix the power cable to the terminal block.
  - When stranded wire is used for the power cable, attach an insulated ring tongue terminal using an appropriate tool.
  - Proper torque is 1.2N·m
3. Fix the ground wire to the terminal block.
  - Proper torque is 1.2N·m
4. Check that the power cable and ground wire are securely fixed to the terminal block.
5. Fix the power cable and ground wire using the accessory cord clip, mounting screw (4x14) and cord clip mounting screw hole.
  - Proper torque is 1.2N·m
  - Clip the sheathed portions of the power cable and ground wire with the cord clip.

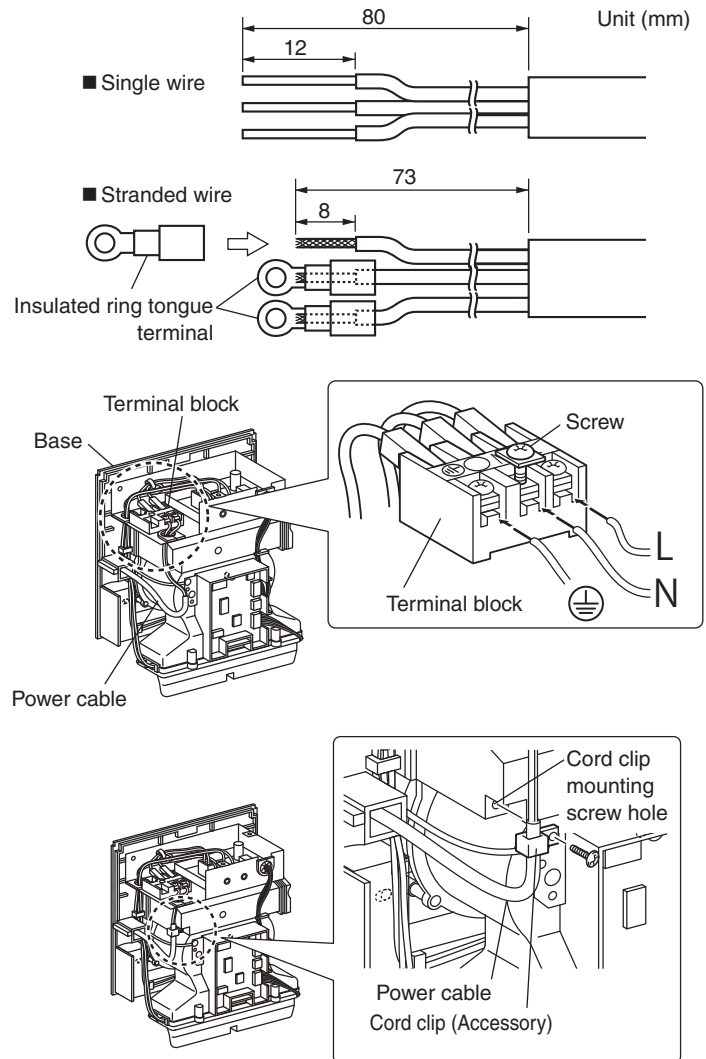

# Installation procedure (continued)

## ■ Checking the setting

- Customer is not allowed to change the setting. The installer should change the initial setting if necessary.
- The initial setting is as shown in the table below.

### Initial setting

Type	Heater	Air speed
JT-S2AP	ON	HIGH
JT-S2A	—*	HIGH

※ JT-S2A does not have the heater switch.

### 1. Check the heater and air speed setting.

- To change the heater setting, refer to "Heater ON/OFF setting".
- To change the air speed setting, refer to "Air speed HIGH/STD\* setting".
- ※ STD : Standard

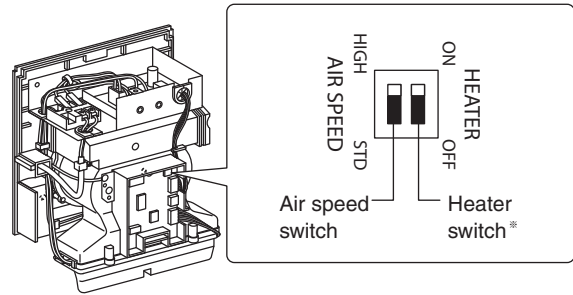

※ JT-S2A does not have the heater switch.

## ■ Heater ON/OFF setting

### ① Turn the heater switch "ON".

※ The heater may not operate during continued use as there is the danger of scalding when the temperature of the warm air rises.

The air may not feel warm when the room temperature is low (20°C or below).

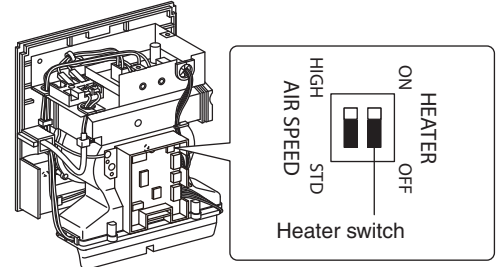

## ■ Air speed HIGH/STD setting

※ STD : Standard

### ① Set the air speed switch to "HIGH" or "STD".

- Refer to "Guide of air speed setting and drying time".

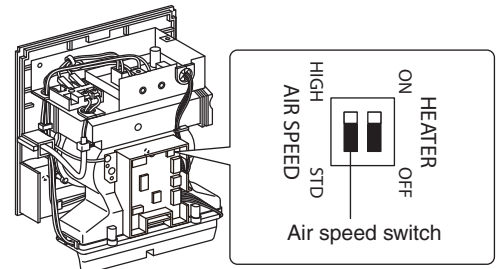

## ■ Guide of air speed setting and drying time

Settings	Drying times guide*	Noise	Use
HIGH	(approx.) 9 – 12 seconds	(approx.) 60 – 62dB	When drying quickly
STD	(approx.) 14 – 16 seconds	(approx.) 58 – 59dB	When keeping the noise level down during operation

※ Drying times are based on Mitsubishi measurements. (50mg of water per hand)

# Installation procedure (continued)

8

1. Pass the power cable through the cord bushing and fix it to the base again with the terminal cover mounting screw.
2. Check that the power cable and wires are not pinched anywhere.

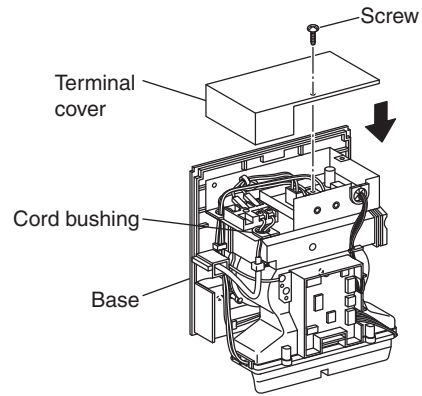

## ■ Attaching the front cover

### NOTE

- Prevent scratching on the front cover. Rust may form on the scratched area. (JT-S2AP only)

1. Fix the ground wire removed in step 3 to the base again. (JT-S2AP only)

2. Attach the front cover to the base.

- ① Fit the front cover to the bottom of the base.
- ② Align the plate inside the front cover with the slit on the right of the base and mount the front cover.

- Do not push the front cover unless the plate inside it is aligned with the slit on the right of the base. Doing so may damage the product.

3. Fix the front cover with the front cover mounting screw (1).

- The screw hole is on the bottom.

4. Check that the tab of the front cover is securely engaged.

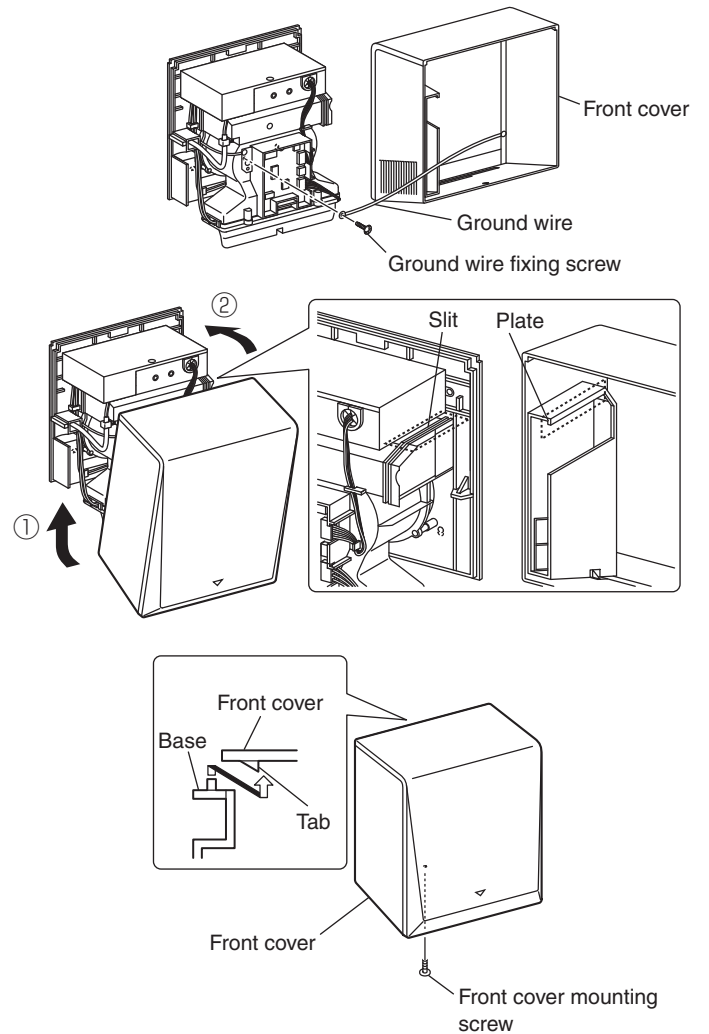

9

# Checking after installation

- When finishing the installation work, check the items in the table below again.  
Be sure to solve a problem if any.  
(Otherwise the expected performance and safety cannot be ensured.)

## ■ Points to be checked

	Item	Description	Check
1	Wiring	Check that the wiring conforms to the extension rules of the technical standards for electrical equipment. (If not, fire may occur.)	
2	Fixation of the main unit	Check that the main unit is securely fixed on a strong surface. (If not, personal injury may occur or the product may fail.)	
3	Power supply voltage	Check that the voltage is 220 - 240 VAC. (If not, the product may fail.)	
4	Grounding	Check that JT-S2AP is securely grounded. (If not, the product may malfunction or fail.)	
5	Setting	Check that the setting is correct. Customer is not allowed to change the setting. Be sure to check the operation if the initial setting is changed. The initial setting is heater "ON" and air speed "HIGH".	

## ■ Removing the front cover after installation

### NOTE

- Prevent scratching on the front cover. Rust may form on the scratched area.  
(JT-S2AP only)

- 1 Remove the front cover mounting screw (1) on the bottom of the main unit.
- 2 Insert a thin stick or the like into near the tab of the upper part of the front cover and disengage the tab.
- 3 Remove the ground wire fixing screw (1) from the base and remove the front cover.  
(JT-S2AP only)
- 4 Perform checking after installation.
  - Check the "Points to be checked".

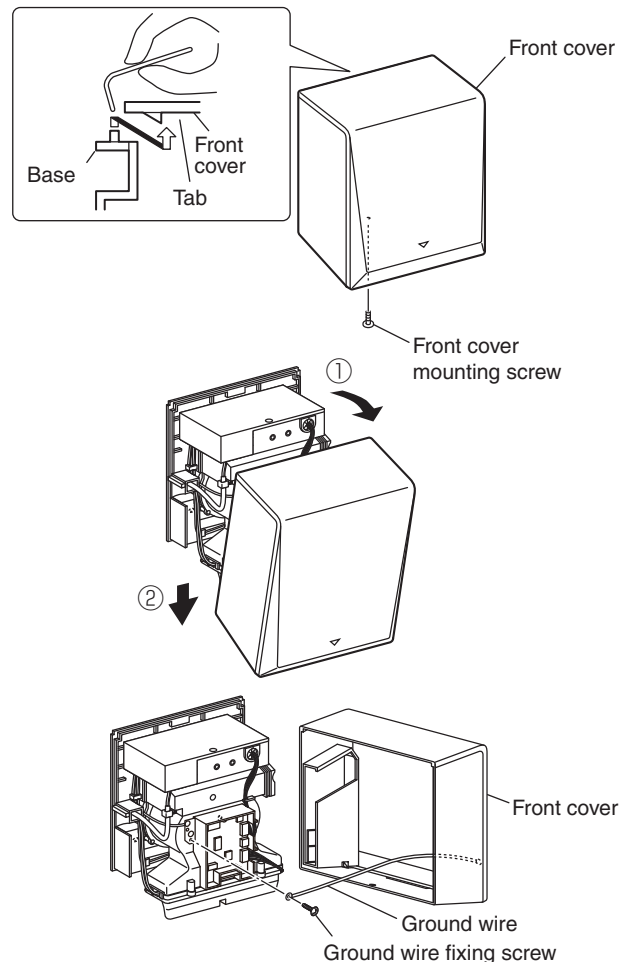

- 5 After inspection, attach the front cover in the reverse order.

# Test Run

	Step	What to check for	Check
1	<b>Check the power supply voltage</b>	<p>Is the proper power being used?            ( <b>Single-phase 220 – 240V AC</b> )</p> <p>Incorrect power supply may cause malfunctions or low wind power.</p>	
2	Turn the ground-fault circuit interrupter "ON"	Are any lights in the display on?	
3	Insert your hands to check if air is being blow.	Is the air blowing?	
		<p>Is warm air blowing? (JT-S2AP only)            ( Even if the heater switch is "ON", the heater may not operate if it is used continually.)</p> <p>※ As the heater is a simple heater, the air may not feel so warm if the room temperature is low (20°C or below).</p>	
4		Is the unit mounted securely without any vibration or abnormal noises?	

## Instructions given to customer

- Explain how to use the jet dryer to customer according to the instruction manual. Especially request customer to observe the important safety instructions in "Safety Precautions".
- Provide customer with this installation manual after completing installation.
- If user is not there, give instructions to caretaker.

## **mitsubishi electric corporation**

HEAD OFFICE: TOKYO BLDG., 2-7-3, MARUNOUCHI, CHIYODA-KU, TOKYO 100-8310, JAPAN

AUTHORIZED REPRESENTATIVE IN EU:

mitsubishi electric europe b.v.

HARMAN HOUSE, 1 GEORGE STREET, UXBRIDGE, MIDDLESEX UB8 1QQ, U.K.

## Information on Disposal



Note: This symbol mark is for EU countries only.

This symbol mark is according to the directive 2012/19/EU Article 14 Information for users and Annex IX, and/or to the directive 2006/66/EC Article 20 Information for end-users and Annex II.

### English

Your MITSUBISHI ELECTRIC product is designed and manufactured with high quality materials and components which can be recycled and/or reused.

This symbol means that electrical and electronic equipment, batteries and accumulators, at their end-of-life, should be disposed of separately from your household waste.

If a chemical symbol is printed beneath the symbol shown above, this chemical symbol means that the battery or accumulator contains a heavy metal at a certain concentration. This will be indicated as follows:

Hg: mercury (0,0005%), Cd: cadmium (0,002%),

Pb: lead (0,004%)

In the European Union there are separate collection systems for used electrical and electronic products, batteries and accumulators.

Please, dispose of this equipment, batteries and accumulators correctly at your local community waste collection/recycling centre.

Please, help us to conserve the environment we live in!

### Deutsch

Ihr MITSUBISHI ELECTRIC-Produkt wurde unter Einsatz von qualitativ hochwertigen Materialien und Komponenten konstruiert und gefertigt, die für Recycling und/oder Wiederverwendung geeignet sind.

Dieses Symbol bedeutet, dass elektrische und elektronische Geräte sowie Batterien und Akkus am Ende ihrer Nutzungsdauer von Hausmüll getrennt zu entsorgen sind.

Wenn ein chemisches Symbol unterhalb des oben abgebildeten Symbols erscheint, bedeutet dies, dass die Batterie bzw. der Akku ein Schwermetall in einer bestimmten Konzentration enthält. Dies wird wie folgt angegeben:

Hg: Quecksilber (0,0005 %), Cd: Cadmium (0,002 %),

Pb: Blei (0,004 %)

In der Europäischen Union gibt es unterschiedliche Sammelsysteme für gebrauchte Elektrik- und Elektronikgeräte einerseits sowie Batterien und Akkus andererseits.

Bitte entsorgen Sie dieses Gerät, Batterien und Akkus vorschriftsmäßig bei Ihrer kommunalen Sammelstelle oder im örtlichen Recycling-Zentrum.

Bitte helfen Sie uns, die Umwelt zu erhalten, in der wir leben!

### Italiano

Questo prodotto MITSUBISHI ELECTRIC è stato progettato e fabbricato con materiali e componenti di alta qualità, che possono essere riciclati e/o riutilizzati.

Questo simbolo significa che i prodotti elettrici ed elettronici, le batterie e gli accumulatori, devono essere smaltiti separatamente dai rifiuti casalinghi alla fine della loro vita di servizio.

Se sotto il simbolo mostrato sopra è stampato un simbolo chimico, il simbolo chimico significa che la batteria o l'accumulatore contiene un metallo pesante con una certa concentrazione. Ciò viene indicato come segue:

Hg: mercurio (0,0005%), Cd: cadmio (0,002%),

Pb: piombo (0,004%)

Nell'Unione Europea ci sono sistemi di raccolta differenziata per i prodotti elettrici ed elettronici, le batterie e gli accumulatori usati.

Per disfarsi di questo prodotto, delle batterie e degli accumulatori, portarli al centro locale di raccolta/riciclaggio dei rifiuti.

Aiutateci a conservare l'ambiente in cui viviamo!

### Français

Votre produit Mitsubishi Electric est conçu et fabriqué avec des matériels et des composants de qualité supérieure qui peuvent être recyclés et/ou réutilisés.

Ce symbole signifie que les équipements électriques et électroniques, les batteries et les accumulateurs, à la fin de leur durée de service, doivent être éliminés séparément des ordures ménagères.

Si un symbole chimique est imprimé sous le symbole illustré ci-dessus, il signifie que la batterie ou l'accumulateur contient une certaine concentration de métal lourd. Elle sera indiquée comme suit :

Hg : mercure (0,0005%), Cd : cadmium (0,002%),

Pb : plomb (0,004%)

Dans l'Union Européenne, il existe des systèmes sélectifs de collecte pour les produits électriques et électroniques, les batteries et les accumulateurs usagés.

Nous vous prions donc de confier cet équipement, ces batteries et ces accumulateurs à votre centre local de collecte/recyclage.

Aidez-nous à conserver l'environnement dans lequel nous vivons !

Les machines ou appareils électriques et électroniques contiennent souvent des matières qui, si elles sont traitées ou éliminées de manière inappropriée, peuvent s'avérer potentiellement dangereuses pour la santé humaine et pour l'environnement.

Cependant, ces matières sont nécessaires au bon fonctionnement de votre appareil ou de votre machine.

Pour cette raison, il vous est demandé de ne pas vous débarrasser de votre appareil ou machine usagé avec vos ordures ménagères.

### Español

Su producto MITSUBISHI ELECTRIC está diseñado y fabricado con materiales y componentes de alta calidad que pueden ser reciclados y/o reutilizados.

Este símbolo significa que el aparato eléctrico y electrónico, las pilas, baterías y los acumuladores, al final de su ciclo de vida, se deben tirar separadamente del resto de sus residuos domésticos.

Si hay un símbolo químico impreso debajo del símbolo mostrado arriba, este símbolo químico significa que la pila, batería o el acumulador contienen un metal pesado con cierta concentración. Esto se indicará de la forma siguiente:

Hg: mercurio (0,0005%), Cd: cadmio (0,002%),

Pb: plomo (0,004%)

En la Unión Europea existen sistemas de recogida específicos para productos eléctricos y electrónicos, pilas, baterías y acumuladores usados.

Por favor, deposite los aparatos mencionados, las pilas, baterías y acumuladores en el centro de recogida/reciclado de residuos de su lugar de residencia local cuando quiera tirarlos.

¡ Ayúdenos a conservar el medio ambiente!

### Português

O seu produto MITSUBISHI ELECTRIC foi concebido e produzido com materiais e componentes de alta qualidade que podem ser reciclados e/ou reutilizados.

Este símbolo significa que o equipamento eléctrico e electrónico, as baterias e os acumuladores, no final da sua vida útil, devem ser deitados fora separadamente do lixo doméstico.

Se houver um símbolo químico impresso por baixo do símbolo mostrado acima, o símbolo químico indica que a bateria ou acumulador contém metais pesados numa determinada concentração. Isto aparecerá indicado da maneira seguinte:

Hg: mercúrio (0,0005%), Cd: cádmio (0,002%),

Pb: chumbo (0,004%)

Na União Europeia existem sistemas de recolha separados para produtos eléctricos e electrónicos, baterias e acumuladores usados.

Por favor, entregue este equipamento, as baterias e os acumuladores correctamente, no seu ponto local de recolha/reciclagem.

Por favor, ajude-nos a conservar o ambiente em que vivemos!





## Svenska

Denna produkt från MITSUBISHI ELECTRIC är designad och tillverkad av material och komponenter med hög kvalitet som kan återvinnas och/eller återanvändas.

Denna symbol betyder att förbrukade elektriska och elektroniska produkter, batterier och ackumulatörer skall sorteras och hanteras separat från hushållsavfall.

Om det finns en kemisk beteckning tryckt under ovanstående symbol betyder det att batteriet eller ackumulatören innehåller en tungmetall med en viss koncentration. Detta anges på följande sätt:

Hg: kvicksilver (0,0005%), Cd: kadmium (0,002%),  
Pb: bly (0,004%)

Inom den Europeiska Unionen finns det separata insamlingsystem för begagnade elektriska och elektroniska produkter, batterier och ackumulatörer.

Var vänlig lämna denna produkt, batterier och ackumulatörer hos din lokala mottagningsstation för avfall och återvinning.

Var snäll och hjälp oss att bevara miljön vi lever i!

## Dansk

Dit produkt fra MITSUBISHI ELECTRIC er designet og fremstillet med kvalitetsmaterialer og komponenter, der kan genindvindes og/eller genbruges.

Dette symbol viser, at elektrisk eller elektronisk udstyr, batterier og akkumulatører ikke må bortskaffes sammen med almindeligt husholdningsaffald efter endt levetid.

Hvis der er trykt et kemisk symbol under symbolet ovenfor, betyder det, at batteriet eller akkumulatøren indeholder en bestemt koncentration af et tungmetall. Dette angives som følger:

Hg: kviksølv (0,0005 %), Cd: cadmium (0,002 %),  
Pb: bly (0,004 %)

I EU er der særlige indsamlingsordninger for brugte elektriske og elektroniske produkter, batterier og akkumulatører.

Bortskaf udstyret, batterier og akkumulatører korrekt på en lokal affalds-/genbrugsplads.

Hjælp os med at bevare det miljø, vi lever i!

## Norsk

For norske brukere:

Dette produktet fra MITSUBISHI ELECTRIC er konstruert og produsert med materialer og komponenter av høy kvalitet, som kan resirkuleres og/eller brukes om igjen.

Dette symbolet betyr at elektrisk og elektronisk utstyr, batterier og akkumulatører, ikke bør kasseres sammen med husholdningsavfallet når de har nådd slutten av sin levetid.

Hvis det er trykt et kjemisk symbol under det symbolet som er vist over, betyr det kjemiske symbolet at batteriet eller akkumulatøren inneholder et tungmetall i en viss konsentrasjon. Dette vil vises som følger:

Hg: kvikksølv (0,0005 %), Cd: kadmium (0,002 %),  
Pb: bly (0,004 %)

I Norge finnes det egne innsamlingsystemer for brukte elektriske og elektroniske produkter, batterier og akkumulatører. Kasser dette utstyret, batteriene og akkumulatørene ved den lokale gjenbruks- eller resirkuleringsstasjonen.

Hjelp oss å bevare det miljøet vi lever i!

## Suomi

Tämä MITSUBISHI ELECTRIC -tuote on suunniteltu ja valmistettu korkealuokkaisista materiaaleista ja/tai osista, jotka voidaan kierrättää ja käyttää uudelleen.

Tämä symboli tarkoittaa, että sähkö- ja elektroniikkalaitteet, paristot ja akut täytyy niiden käyttöänsä jälkeen hävittää erillään talousjätteistä.

Jos yllä olevan symbolin alapuolelle on painettu kemiallinen symboli, se tarkoittaa, että paristolla tai akulla on tietty raskasmetallipitoisuus. Se ilmoitetaan seuraavasti:

Hg: elohopea (0,0005 %), Cd: kadmium (0,002 %),  
Pb: lyijy (0,004 %)

Käytetyillä sähkö- ja elektroniikkalaitteilla, paristoilla ja akuilla on Euroopan Yhteisössä omat keräysjärjestelmänsä.

Toimita tämä laite, paristot ja akut paikalliseen jätehuolto-/kierrätyskeskukseen.

Auta meitä suojelemaan ympäristöä, jossa elämme!

## Nederlands

Mitsubishi Electric producten zijn ontwikkeld en gefabriceerd uit eerste kwaliteit materialen. De onderdelen kunnen worden gerecycled en/of worden hergebruikt.

Het symbool betekent dat de elektrische en elektronische onderdelen, batterijen en accu's op het einde van de gebruiksduur gescheiden van het huishoudelijk afval moeten worden ingezameld. Wanneer er onder het bovenstaande symbool een chemisch symbool staat gedrukt, betekent dit dat de batterij of accu zware metalen in een bepaalde concentratie bevat. Dit wordt als volgt aangeduid:

Hg: kwik (0,0005%), Cd: cadmium (0,002%),  
Pb: lood (0,004%)

In de Europese Unie worden elektrische en elektronische producten, batterijen en accu's afzonderlijk ingezameld.

Breng deze apparatuur, batterijen en accu's dan naar het gemeentelijke afvalinzamelingspunt.

Help ons mee het milieu te beschermen!

## Ελληνικά

Το προϊόν MITSUBISHI ELECTRIC που διαθέτετε είναι σχεδιασμένο και κατασκευασμένο από υλικά και εξαρτήματα υψηλής ποιότητας, τα οποία μπορούν να ανακυκλωθούν ή/και να χρησιμοποιηθούν ξανά.

Το σύμβολο αυτό σημαίνει ότι ο ηλεκτρικός και ηλεκτρονικός εξοπλισμός, οι μπαταρίες και οι συσσωρευτές, στο τέλος της διάρκειας ζωής τους, θα πρέπει να απορριφθούν ξεχωριστά από τα υπόλοιπα οικιακά απορρίμμά σας.

Αν έχει εκτυπωθεί ένα χημικό σύμβολο κάτω από το σύμβολο που απεικονίζεται ανωτέρω, αυτό το χημικό σύμβολο σημαίνει ότι η μπαταρία ή ο συσσωρευτής περιέχει ένα βαρύ μέταλλο σε ορισμένη συγκέντρωση. Αυτό θα υποδεικνύεται ως ακολούθως:

Hg: υδράργυρος (0,0005%), Cd: κάδμιο (0,002%),  
Pb: μόλυβδος (0,004%)

Στην Ευρωπαϊκή Ένωση υπάρχουν ξεχωριστά συστήματα συλλογής για τα χρησιμοποιημένα ηλεκτρικά και ηλεκτρονικά προϊόντα, τις μπαταρίες και τους συσσωρευτές.

Παρακαλούμε διαθέστε αυτόν τον εξοπλισμό, τις μπαταρίες και τους συσσωρευτές στο τοπικό σας κοινοτικό κέντρο συλλογής/ανακύκλωσης απορριμμάτων.

Βοηθήστε μας να προστατεύσουμε το περιβάλλον στο οποίο ζούμε!

### Technical Document of Fan Efficiency

Model Name	JT-S2AP, JT-S2A
Overall Efficiency	54.0%
Measurement Category	C
Efficiency Category	Static
Efficiency Grade	61
VSD	A variable speed drive is integrated within the fan
Year of Manufacture	2015
Manufacturer	Mitsubishi Electric Corporation Head Office: Tokyo Bldg., 2-7-3, Marunouchi, Chiyoda-ku, Tokyo 100-8310, Japan Authorised representative in EU: Mitsubishi Electric Europe B.V.: 1 George Street, Harman House, Uxbridge, Middlesex, UB81QQ Commercial registration no. 33279602
Motor Power Input (kW)	0.67
Flow Rate (m <sup>3</sup> /s)	0.02
Pressure (Pa)	16,520
Rotations per Minute	34,847
Specific Ratio	1.0
Information relevant for facilitating disassembly, recycling or disposal at end-of-life	Your product should be disposed of separately from household waste in line with local laws and regulations. When this product reaches its end of life, dispose of it at your local waste collection point/recycling centre. The separate collection and recycling of your product at the time of disposal will help conserve natural resources and ensure that it is recycled in a manner that protects human health and the environment. For more information for WEEE recyclers please contact us at <a href="http://www.mitsubishielectric.eu/contact_us_form">http://www.mitsubishielectric.eu/contact_us_form</a>
Information relevant to minimise impact on the environment and ensure optimal life expectancy as regards installation, use and maintenance of the fan	Remove dust on air filter around once a week.
Description of additional items used when determining the fan energy efficiency	The optimistic fan efficiency is measured in the composition of fan, motor and fan casing only.

# CHECK SHEET FICHE DE CONTRÔLE เอกสารรายการสิ่งที่ต้องตรวจสอบ 检查表 檢視表單 КОНТРОЛЬНЫЙ ЛИСТ

Current fuse in control circuit Fusibles à intensité du circuit de commande	
ฟิวส์กระแสไฟในวงจรควบคุม	FUSE1.....250 V - 20 A
控制电路内的电流保险丝	FUSE2.....250 V - 5 A
控制電路內的電流保險絲	(JT-S2AP ONLY)
Плавкая вставка по току в цепи управления	FUSE3.....250 V - 6.3 A

Thermal fuse fusion temperature	Température de fusion du fusible thermique	อุณหภูมิหลอมละลายของเทอร์โมฟิวส์	温度保險絲熔斷溫度	溫度保險絲熔斷溫度	Температура плавления термopредохранителя
<b>THERMAL FUSE1</b> (Thermal fuse in motor Fusible thermique dans le moteur) เทอร์โมฟิวส์ในมอเตอร์ 马达內溫度保險絲 馬達溫度保險絲 Термопредохранитель двигателя	.....94°C	<b>THERMAL FUSE2 (JT-S2AP ONLY)</b> (Thermal fuse in heater Fusible thermique du réchauffeur) เทอร์โมฟิวส์ในเครื่องทำความร้อน 加热器內溫度保險絲 加熱器溫度保險絲 Термопредохранитель нагревателя	.....94°C		

## Malfunction location quick reference chart (The display LED light is displayed in the blinking location)

- : Lit      ☆ : Blinking (every 0.4 sec)      ● : Unlit
- Allumé    Clignote (toutes les 0,4 sec.)      Éteint
- ติด        กระพริบ (ทุก 0.4 วินาที)           ดับ
- 点亮      闪亮 (每0.4秒一次)                熄灭
- 點亮      閃爍 (每0.4秒一次)                熄滅
- Горит     Мигает (каждые 0,4 с)            Не горит

### <Blinking cycle>

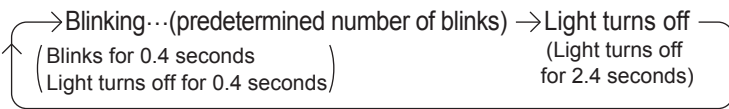

Ex: "Motor abnormality 1" blinks 3 times

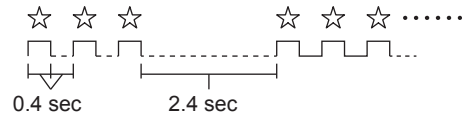

### <Cycle de clignotement>

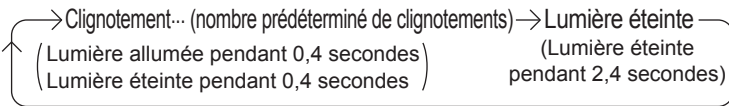

Ex. : « Anomalie moteur 1 » clignote 3 fois

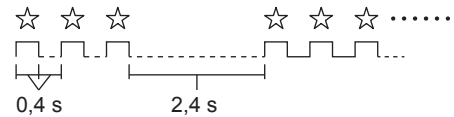

### <รอบการกระพริบ>

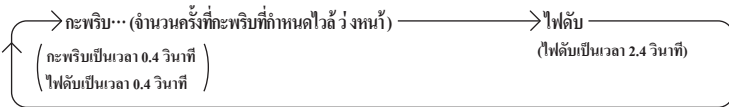

ตัวอย่าง: "การทำงานผิดปกติของมอเตอร์ 1" กระพริบ 3 ครั้ง

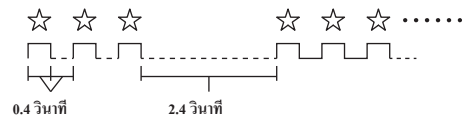

### <闪烁循环>

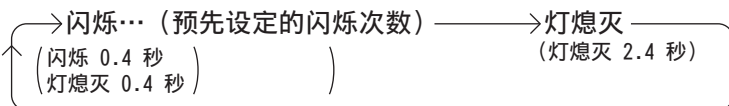

示例: "马达异常 1" 将闪烁 3 次

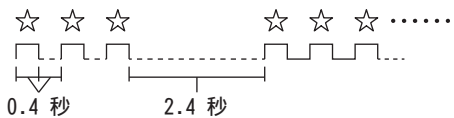

### <閃爍迴圈>

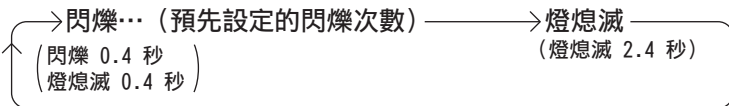

示例: 「馬達異常 1」將閃爍 3 次

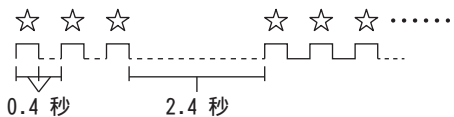

### <Цикл мигания>

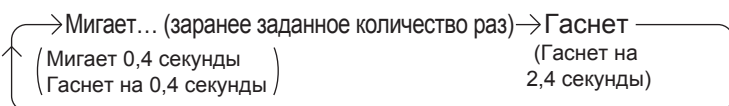

Напр.: «Нарушение в работе двигателя 1» Мигает 3 раза

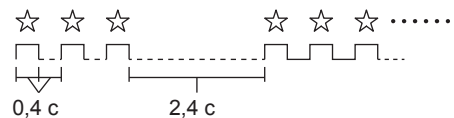

Description		POWER (LED1)	Main cause of error
Normal	When normal	○	-
	Tamper prevention	☆	30-second continuous operation (automatic return)
Abnormal	Power-supply detection abnormality	2 blinks	Power-supply noise (automatic return)
	Motor abnormality 1	3 blinks	Motor: lock/connector detached
	Motor abnormality 2	4 blinks	Motor: brush life limit/brush abnormality
	Power board temperature abnormality	5 blinks	Power board: high-temperature/low-temperature (automatic return)
	Main board temperature abnormality	6 blinks	Main board: high-temperature/low-temperature (automatic return)
	Microcomputer abnormality	7 blinks	Microcomputer abnormality (main board)
Power-supply OFF/fuse melting		●	Power-supply OFF, electric current fuse and temperature fuse melting

Description		ALIMENTATION (LED1)	Cause principale de l'erreur
Normal	En situation normale	○	-
	Prévention des altérations	☆	Fonctionnement continu pendant 30 secondes (retour automatique)
Anormal	Anomalie de détection de l'alimentation électrique	2 clignotements	Bruit de l'alimentation électrique (retour automatique)
	Anomalie moteur 1	3 clignotements	Moteur : verrou/connecteur détaché
	Anomalie moteur 2	4 clignotements	Moteur : limite de durée de vie des balais/anomalie des balais
	Anomalie de la température de la carte d'alimentation	5 clignotements	Carte d'alimentation : température élevée/basse température (retour automatique)
	Anomalie de température de la carte principale	6 clignotements	Carte principale : température élevée/basse température (retour automatique)
	Anomalie micro-ordinateur	7 clignotements	Anomalie micro-ordinateur (carte principale)
Alimentation électrique arrêtée/fusible fondu		●	Alimentation électrique arrêtée, fusible de courant électrique et fusible de température fondus

คำอธิบาย		เปิดปิด (LED 1)	สาเหตุหลักที่ทำให้เกิดข้อผิดพลาด
ปกติ	เมื่ออยู่ในสภาวะปกติ	○	-
	การป้องกันการแทรกแซงการทำงาน	☆	การใช้งานอย่างต่อเนื่อง 30 วินาที (กลับมาทำงานใหม่โดยอัตโนมัติ)
ผิดปกติ	การตรวจับการทำงานผิดปกติของแหล่งจ่ายไฟ	กะพริบ 2 ครั้ง	สัญญาณรบกวนของแหล่งจ่ายไฟ (กลับมาทำงานใหม่โดยอัตโนมัติ)
	การทำงานผิดปกติของมอเตอร์ 1	กะพริบ 3 ครั้ง	มอเตอร์: ล็อก/ขั้วต่อถูกปลดออก
	การทำงานผิดปกติของมอเตอร์ 2	กะพริบ 4 ครั้ง	มอเตอร์: ถึงขีดจำกัดอายุการใช้งานของแปรง/การทำงานผิดปกติของแปรง
	อุณหภูมิของแผงไฟผิดปกติ	กะพริบ 5 ครั้ง	แผงไฟ: อุณหภูมิสูง/อุณหภูมิต่ำ (กลับมาทำงานใหม่โดยอัตโนมัติ)
	อุณหภูมิของแผงวงจรหลักผิดปกติ	กะพริบ 6 ครั้ง	แผงวงจรหลัก: อุณหภูมิสูง/อุณหภูมิต่ำ (กลับมาทำงานใหม่โดยอัตโนมัติ)
	การทำงานผิดปกติของไมโครคอมพิวเตอร์	กะพริบ 7 ครั้ง	การทำงานผิดปกติของไมโครคอมพิวเตอร์ (แผงวงจรหลัก)
แหล่งจ่ายไฟปิดการทำงาน/ฟิวส์หลอมละลาย		●	แหล่งจ่ายไฟปิดการทำงาน, ฟิวส์กระแสไฟฟ้าและเทอร์มิสแตร์ไม่ฟิวส์หลอมละลาย

描述		电源 (LED1)	主要错误原因
正常	正常情况下	○	-
	预防篡改	☆	30 秒连续操作 (自动返回)
异常	电源检测异常	闪烁 2 次	电源噪音 (自动返回)
	马达异常 1	闪烁 3 次	马达: 锁定/连接器分离
	马达异常 2	闪烁 4 次	马达: 电刷寿命极限/电刷异常
	电源板温度异常	闪烁 5 次	电源板: 高温/低温 (自动返回)
	主板温度异常	闪烁 6 次	主板: 高温/低温 (自动返回)
	微机异常	闪烁 7 次	微机异常 (主板)
电源关闭/保险丝熔断		●	电源关闭, 电流保险丝和温度保险丝均熔断

描述		電源 (LED1)	主要出錯原因
正常	正常情况下	○	-
	預防篡改	☆	30 秒連續作業 (自動返回)
異常	電源檢測異常	閃爍 2 次	電源噪音 (自動返回)
	馬達異常 1	閃爍 3 次	馬達: 鎖定/連接器分離
	馬達異常 2	閃爍 4 次	馬達: 電刷壽命極限/電刷異常
	電源板溫度異常	閃爍 5 次	電源板: 高溫/低溫 (自動返回)
	主機板溫度異常	閃爍 6 次	主機板: 高溫/低溫 (自動返回)
	微機異常	閃爍 7 次	微機異常 (主機板)
電源關閉/保險絲熔斷		●	電源關閉, 電流保險絲和溫度保險絲均熔斷

Описание		ПИТАНИЕ (СВЕТОДИОД 1)	Главная причина ошибки
При нормальной работе	При нормальной работе	○	-
	Предотвращение вмешательства	☆	30-секундная непрерывная работа (автоматический возврат)
Нарушения в работе	Сбой в обнаружении подачи питания	Мигает 2 раза	Помехи по цепям питания (автоматический возврат)
	Нарушение в работе двигателя 1	Мигает 3 раз	Двигатель: блокировка/отсоединение коннектора
	Нарушение в работе двигателя 2	Мигает 4 раза	Двигатель: предельный срок службы щеток/нарушение в работе щеток
	Отклонение в температуре платы питания	Мигает 5 раз	Плата питания: высокая температура/низкая температура (автоматический возврат)
	Отклонение в температуре главной платы	Мигает 6 раз	Главная плата: высокая температура/низкая температура (автоматический возврат)
	Нарушение в работе микрокомпьютера	Мигает 7 раз	Нарушение в работе микрокомпьютера (главная плата)
Отключение питания/плавление предохранителя		●	Отключение питания, плавление термopредохранителя и плавкой вставки по электроток