

Air to Water Heat Pump

PUHZ-SW·HA series

PUHZ-SW·KA series

INSTALLATION MANUAL

For safe and correct use, read this manual and the indoor unit installation manual thoroughly before installing the outdoor unit. English is original. The other languages versions are translation of the original.

FOR INSTALLER

English

INSTALLATIONSHANDBUCH

Aus Sicherheitsgründen und zur richtigen Verwendung vor der Installation der Außenanlage das vorliegende Handbuch und die Installationsanleitung der Innenanlage gründlich durchlesen. Das Original ist in Englisch. Die anderen Sprachversionen sind vom Original übersetzt.

FÜR INSTALLATEURE

Deutsch

MANUEL D'INSTALLATION

Avant d'installer l'appareil extérieur, lire attentivement ce manuel, ainsi que le manuel d'installation de l'appareil intérieur pour une utilisation sûre et correcte. L'anglais est l'original. Les versions fournies dans d'autres langues sont des traductions de l'original.

POUR L'INSTALLATEUR

Français

INSTALLATIEHANDLEIDING

Lees deze handleiding en de installatiehandleiding van het binnenapparaat zorgvuldig door voordat u met het installeren van het buitenapparaat begint. Het Engels is het origineel. De andere taalversies zijn vertalingen van het origineel.

VOOR DE INSTALLATEUR

Nederlands

MANUAL DE INSTALACIÓN

Para un uso correcto y seguro, lea detalladamente este manual y el manual de instalación de la unidad interior antes de instalar la unidad exterior. El idioma original del documento es el inglés. Las versiones en los demás idiomas son traducciones del original.

PARA EL INSTALADOR

Español

MANUALE DI INSTALLAZIONE

Per un uso sicuro e corretto, leggere attentamente il presente manuale ed il manuale d'installazione dell'unità interna prima di installare l'unità esterna. Il testo originale è redatto in lingua Inglese. Le altre versioni linguistiche rappresentano traduzioni dell'originale.

PER L'INSTALLATORE

Italiano

ΕΓΧΕΙΡΙΔΙΟ ΟΔΗΓΙΩΝ ΕΓΚΑΤΑΣΤΑΣΗΣ

Για σωστή και ασφαλή χρήση, διαβάστε προσεκτικά αυτό το εγχειρίδιο καθώς και το εγχειρίδιο εγκατάστασης της εσωτερικής μονάδας, προτού εγκαταστήσετε την εξωτερική μονάδα. Η γλώσσα του πρωτοτύπου είναι η αγγλική. Οι εκδόσεις άλλων γλωσσών είναι μεταφράσεις του πρωτοτύπου.

ΓΙΑ ΑΥΤΟΝ ΠΟΥ ΚΑΝΕΙ ΤΗΝ ΕΓΚΑΤΑΣΤΑΣΗ

Ελληνικά

MANUAL DE INSTALAÇÃO

Para uma utilização segura e correcta, leia atentamente este manual e o manual de instalação da unidade interior antes de instalar o aparelho de unidade exterior. O idioma original é o inglês. As versões em outros idiomas são traduções do idioma original.

PARA O INSTALADOR

Português

INSTALLATIONSMANUAL

Læs af sikkerhedshensyn denne manual samt manualen til installation af indendørsenheden grundigt, før du installerer udendørsenheden. Engelsk er originalen. De andre sprogversioner er oversættelser af originalen.

TIL INSTALLATØREN

Dansk

INSTALLATIONSMANUAL

Läs bruksanvisningen och inomhusenhetens installationshandbok noga innan utomhusenhet installeras så att den används på ett säkert och korrekt sätt. Engelska är originalspråket. De övriga språkversionerna är översättningar av originalet.

FÖR INSTALLATÖREN

Svenska

MONTAJ ELKİTABI

Emniyetli ve doğru kullanım için, dış üniteyi monte etmeden önce bu kılavuzu ve iç ünite montaj kılavuzunu tamamiyle okuyun. Aslı İngilizce'dir. Diğer dillerdeki sürümler aslının çevirisidir.

MONTÖR İÇİN

Türkçe

РУКОВОДСТВО ПО УСТАНОВКЕ

Для обеспечения безопасной и надлежащей эксплуатации внимательно прочтите данное руководство и руководство по установке внутреннего прибора перед установкой наружного прибора. Языком оригинала является английский. Версии на других языках являются переводом оригинала.

ДЛЯ УСТАНОВИТЕЛЯ

Русский

INSTALLASJONSHÅNDBOK

For å sikre trygg og riktig bruk skal denne håndboken samt installasjonshåndboken for innendørsenheten leses grundig igjennom før enheten installeres. Engelsk er originalspråket. De andre språkversjonene er oversettelser av originalen.

FOR MONTØR

Norsk

ASENNUSOPAS

Turvallisen ja asianmukaisen käytön varmistamiseksi lue tämä opas sekä sisäyksikön asennusopas huolellisesti ennen yksikön asentamista. Alkuperäiskieli on englanti. Muut kieliversiot ovat alkuperäisen käännöksiä.

ASENTAJALLE

Suomi

Contents

1. Safety precautions.....	2	6. Water piping work	9
2. Installation location.....	3	7. Electrical work	10
3. Installing the outdoor unit.....	5	8. Special Functions	12
4. Installing the refrigerant piping.....	5	9. System control.....	12
5. Drainage piping work.....	9	10. Specifications	12



Note: This symbol mark is for EU countries only.

This symbol mark is according to the directive 2012/19/EU Article 14 Information for users and Annex IX.

Your MITSUBISHI ELECTRIC product is designed and manufactured with high quality materials and components which can be recycled and reused.

This symbol means that electrical and electronic equipment, at their end-of-life, should be disposed of separately from your household waste.

Please, dispose of this equipment at your local community waste collection/recycling centre.

In the European Union there are separate collection systems for used electrical and electronic product.

Please, help us to conserve the environment we live in!

⚠ Caution:

• Do not vent R410A into the Atmosphere:

• R410A is a Fluorinated Greenhouse gas, covered by the Kyoto Protocol, with a Global Warming Potential (GWP)=1975.

■ Heat pumps certification

The mark "NF Heat pumps" is an independent certification program proving that heat pumps' performances and production quality of the factory are conformed with the certification reference NF-414. The combinations of indoor units and outdoor units, and their applications allowed to use the NF PAC mark can be consulted on the website www.marque-nf.com

1. Safety precautions

▶ Before installing the unit, make sure you read all the "Safety precautions".
▶ Please report to or take consent by the supply authority before connection to the system.

▶ Equipment complying with IEC/EN 61000-3-12 (PUHZ-SW100/120VHA)

▶ PUHZ-SW160, 200YKA

"This equipment complies with IEC 61000-3-12 provided that the short-circuit power Ssc is greater than or equal to Ssc (*1) at the interface point between the user's supply and the public system. It is the responsibility of the installer or user of the equipment to ensure, by consultation with the distribution network operator if necessary, that the equipment is connected only to a supply with a short-circuit power Ssc greater than or equal to Ssc (*1)"

Model	Ssc (MVA)
PUHZ-SW160YKA	1.35
PUHZ-SW200YKA	1.49

⚠ Warning:

Describes precautions that must be observed to prevent danger of injury or death to the user.

⚠ Caution:

Describes precautions that must be observed to prevent damage to the unit.

After installation work has been completed, explain the "Safety Precautions," use, and maintenance of the unit to the customer according to the information in the Operation Manual and perform the test run to ensure normal operation. Both the Installation Manual and Operation Manual must be given to the user for keeping. These manuals must be passed on to subsequent users.

⚡ : Indicates a part which must be grounded.

⚠ Warning:

Carefully read the labels affixed to the main unit.

⚠ Warning:

- The unit must not be installed by the user. Ask a dealer or an authorized technician to install the unit. If the unit is installed incorrectly, water leakage, electric shock, or fire may result.
- For installation work, follow the instructions in the Installation Manual and use tools and pipe components specifically made for use with R410A refrigerant. The R410A refrigerant in the HFC system is pressurized 1.6 times the pressure of usual refrigerants. If pipe components not designed for R410A refrigerant are used and the unit is not installed correctly, the pipes may burst and cause damage or injuries. In addition, water leakage, electric shock, or fire may result.
- The unit must be installed according to the instructions in order to minimize the risk of damage from earthquakes, typhoons, or strong winds. An incorrectly installed unit may fall down and cause damage or injuries.
- The unit must be securely installed on a structure that can sustain its weight. If the unit is mounted on an unstable structure, it may fall down and cause damage or injuries.
- If the outdoor unit is installed in a small room, measures must be taken to prevent the refrigerant concentration in the room from exceeding the safety limit in the event of refrigerant leakage. Consult a dealer regarding the appropriate measures to prevent the allowable concentration from being exceeded. Should the refrigerant leak and cause the concentration limit to be exceeded, hazards due to lack of oxygen in the room may result.
- Ventilate the room if refrigerant leaks during operation. If refrigerant comes into contact with a flame, poisonous gases will be released.
- All electric work must be performed by a qualified technician according to local regulations and the instructions given in this manual. The units must be powered by dedicated power lines and the correct voltage and circuit breakers must be used. Power lines with insufficient capacity or incorrect electrical work may result in electric shock or fire.
- Use C1220 copper phosphorus, for copper and copper alloy seamless pipes, to connect the refrigerant pipes. If the pipes are not connected correctly, the unit will not be properly grounded and electric shock may result.

- Use only specified cables for wiring. The wiring connections must be made securely with no tension applied on the terminal connections. Also, never splice the cables for wiring (unless otherwise indicated in this document). Failure to observe these instructions may result in overheating or a fire.
- The terminal block cover panel of the outdoor unit must be firmly attached. If the cover panel is mounted incorrectly and dust and moisture enter the unit, electric shock or fire may result.
- When installing or relocating, or servicing the outdoor unit, use only the specified refrigerant (R410A) to charge the refrigerant lines. Do not mix it with any other refrigerant and do not allow air to remain in the lines. If air is mixed with the refrigerant, then it can be the cause of abnormal high pressure in the refrigerant line, and may result in an explosion and other hazards. The use of any refrigerant other than that specified for the system will cause mechanical failure or system malfunction or unit breakdown. In the worst case, this could lead to a serious impediment to securing product safety.
- Use only accessories authorized by Mitsubishi Electric and ask a dealer or an authorized technician to install them. If accessories are incorrectly installed, water leakage, electric shock, or fire may result.
- Do not alter the unit. Consult a dealer for repairs. If alterations or repairs are not performed correctly, water leakage, electric shock, or fire may result.
- The user should never attempt to repair the unit or transfer it to another location. If the unit is installed incorrectly, water leakage, electric shock, or fire may result. If the outdoor unit must be repaired or moved, ask a dealer or an authorized technician.
- After installation has been completed, check for refrigerant leaks. If refrigerant leaks into the room and comes into contact with the flame of a heater or portable cooking range, poisonous gases will be released.

1.1. Before installation

⚠ Caution:

- Do not use the unit in an unusual environment. If the outdoor unit is installed in areas exposed to steam, volatile oil (including machine oil), or sulfuric gas, areas exposed to high salt content such as the seaside, or areas where the unit will be covered by snow, the performance can be significantly reduced and the internal parts can be damaged.
- Do not install the unit where combustible gases may leak, be produced, or be ignited.
- The outdoor unit produces condensation during the heating operation. Make sure to provide drainage around the outdoor unit if such condensation is likely to cause damage.
- When installing the unit in a hospital or communications office, be prepared for noise and electronic interference. Inverters, home appliances, high-frequency medical equipment, and radio communications equipment

1. Safety precautions

1.2. Before installation (relocation)

⚠ Caution:

- Be extremely careful when transporting or installing the units. Two or more persons are needed to handle the unit, as it weighs 20 kg or more. Do not grasp the packaging bands. Wear protective gloves to remove the unit from the packaging and to move it, as you can injure your hands on the fins or the edge of other parts.
- Be sure to safely dispose of the packaging materials. Packaging materials, such as nails and other metal or wooden parts may cause stabs or other injuries.

1.3. Before electric work

⚠ Caution:

- Be sure to install circuit breakers. If not installed, electric shock may result.
- For the power lines, use standard cables of sufficient capacity. Otherwise, a short circuit, overheating, or fire may result.
- When installing the power lines, do not apply tension to the cables. If the connections are loosened, the cables can snap or break and overheating or fire may result.

1.4. Before starting the test run

⚠ Caution:

- Turn on the main power switch more than 12 hours before starting operation. Starting operation just after turning on the power switch can severely damage the internal parts. Keep the main power switch turned on during the operation season.
- Before starting operation, check that all panels, guards and other protective parts are correctly installed. Rotating, hot, or high voltage parts can cause injuries.
- Do not touch any switch with wet hands. Electric shock may result.

1.5. Using R410A refrigerant outdoor units

⚠ Caution:

- Use C1220 copper phosphorus, for copper and copper alloy seamless pipes, to connect the refrigerant pipes. Make sure the insides of the pipes are clean and do not contain any harmful contaminants such as sulfuric compounds, oxidants, debris, or dust. Use pipes with the specified thickness. (Refer to 4.1.) Note the following if reusing existing pipes that carried R22 refrigerant.
 - Replace the existing flare nuts and flare the flared sections again.
 - Do not use thin pipes. (Refer to 4.1.)
- Store the pipes to be used during installation indoors and keep both ends of the pipes sealed until just before brazing. (Leave elbow joints, etc. in their packaging.) If dust, debris, or moisture enters the refrigerant lines, oil deterioration or compressor breakdown may result.
- Use ester oil, ether oil, alkylbenzene oil (small amount) as the refrigeration oil applied to the flared sections. If mineral oil is mixed in the refrigeration oil, oil deterioration may result.

- The base and attachments of the outdoor unit must be periodically checked for looseness, cracks or other damage. If such defects are left uncorrected, the unit may fall down and cause damage or injuries.
- Do not clean the outdoor unit with water. Electric shock may result.
- Tighten all flare nuts to specification using a torque wrench. If tightened too much, the flare nut can break after an extended period and refrigerant can leak out.

- Be sure to ground the unit. Do not connect the ground wire to gas or water pipes, lightning rods, or telephone grounding lines. If the unit is not properly grounded, electric shock may result.
- Use circuit breakers (ground fault interrupter, isolating switch (+B fuse), and molded case circuit breaker) with the specified capacity. If the circuit breaker capacity is larger than the specified capacity, breakdown or fire may result.

- Do not touch the refrigerant pipes with bare hands during operation. The refrigerant pipes are hot or cold depending on the condition of the flowing refrigerant. If you touch the pipes, burns or frostbite may result.
- After stopping operation, be sure to wait at least five minutes before turning off the main power switch. Otherwise, water leakage or breakdown may result.

- Do not use refrigerant other than R410A refrigerant. If another refrigerant is used, the chlorine will cause the oil to deteriorate.
- Use the following tools specifically designed for use with R410A refrigerant. The following tools are necessary to use R410A refrigerant. Contact your nearest dealer for any questions.

Tools (for R410A)	
Gauge manifold	Flare tool
Charge hose	Size adjustment gauge
Gas leak detector	Vacuum pump adapter
Torque wrench	Electronic refrigerant charging scale

- Be sure to use the correct tools. If dust, debris, or moisture enters the refrigerant lines, refrigeration oil deterioration may result.
- Do not use a charging cylinder. If a charging cylinder is used, the composition of the refrigerant will change and the efficiency will be lowered.

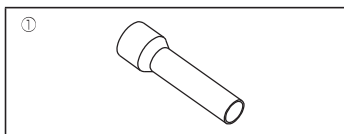

Fig. 1-1

1.6. Accessories of outdoor unit (Fig. 1-1) (SW160, 200)

The parts shown in the left are the accessories of this unit, which are affixed to the inside of the service panel.

① Joint Pipe accessory.....×1

- (1) Put flare nut which is removed from the Ball Valve on the Joint Pipe accessory and carry out flare work.
- (2) The Joint Pipe accessory and the pipe which is prepared on site must be brazed in non-oxidation status.
- (3) After the pipes are brazed, connect the Joint Pipe accessory to the Ball Valve which locates within the unit by flare connection.

* Never connect the Joint Pipe accessory to the Ball Valve before brazing. Some parts may be burnt and it may cause refrigerant leakage.

2. Installation location

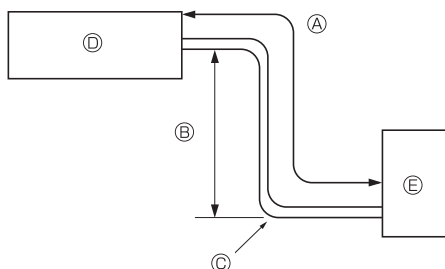

Fig. 2-1

2.1. Refrigerant pipe (Fig. 2-1)

► Check that the difference between the heights of the indoor and outdoor units, the length of refrigerant pipe, and the number of bends in the pipe are within the limits shown below.

Model	Ⓐ Pipe length (one way)	Ⓑ Height difference	Ⓒ Number of bends (one way)
SW40, 50, 75	2 m - 40 m	Max. 10 m	Max. 15
SW100, 120	2 m - 75 m	Max. 30 m	Max. 15
SW160, 200	2 m - 80 m	Max. 30 m	Max. 15

- Height difference limitations are binding regardless of which unit, indoor or out-

2. Installation location

■ SW40, 50

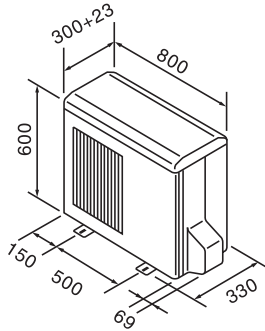

■ SW75, 100, 120, 160, 200

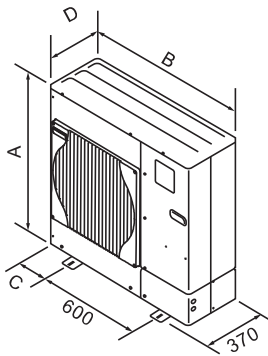

Model	A (mm)	B (mm)	C (mm)	D (mm)
SW75	943	950	175	330 + 30
SW100	1350	950	175	330 + 30
SW120	1350	950	175	330 + 30
SW160	1338	1050	225	330 + 40
SW200	1338	1050	225	330 + 40

Fig. 2-2

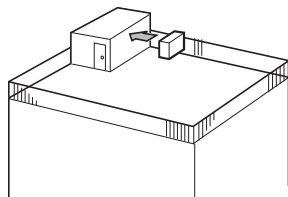

Fig. 2-3

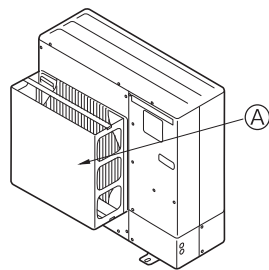

Fig. 2-4

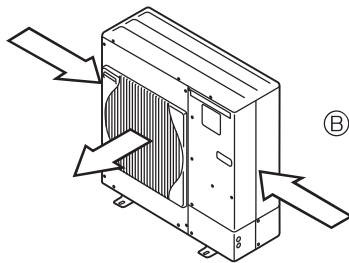

Fig. 2-5

2.2. Choosing the outdoor unit installation location

- Avoid locations exposed to direct sunlight or other sources of heat.
- Select a location from which noise emitted by the unit will not inconvenience neighbors.
- Select a location permitting easy wiring and pipe access to the power source and indoor unit.
- Avoid locations where combustible gases may leak, be produced, flow, or accumulate.
- Note that water may drain from the unit during operation.
- Select a level location that can bear the weight and vibration of the unit.
- Avoid locations where the unit can be covered by snow. In areas where heavy snow fall is anticipated, special precautions such as raising the installation location or installing a hood on the air intake must be taken to prevent the snow from blocking the air intake or blowing directly against it. This can reduce the airflow and a malfunction may result.
- Avoid locations exposed to oil, steam, or sulfuric gas.
- Use the transportation handles of the outdoor unit to transport the unit. If the unit is carried from the bottom, hands or fingers may be pinched.

2.3. Outline dimensions (Outdoor unit) (Fig. 2-2)

2.4. Ventilation and service space

2.4.1. Windy location installation

When installing the outdoor unit on a rooftop or other location unprotected from the wind, situate the air outlet of the unit so that it is not directly exposed to strong winds. Strong wind entering the air outlet may impede the normal airflow and a malfunction may result.

The following shows three examples of precautions against strong winds.

- ① Face the air outlet towards the nearest available wall about 50 cm away from the wall. (Fig. 2-3)
- ② Install an optional air guide if the unit is installed in a location where strong winds from a typhoon, etc. may directly enter the air outlet. (Fig. 2-4)
 - Ⓐ Air outlet guide
- ③ Position the unit so that the air outlet blows perpendicularly to the seasonal wind direction, if possible. (Fig. 2-5)
 - Ⓑ Wind direction

2.4.2. When installing a single outdoor unit (Refer to the last page)

Minimum dimensions are as follows, except for Max., meaning Maximum dimensions, indicated.

The figures in parentheses are for SW100-200 models.

Refer to the figures for each case.

- ① Obstacles at rear only (Fig. 2-6)
- ② Obstacles at rear and above only (Fig. 2-7)
- ③ Obstacles at rear and sides only (Fig. 2-8)
 - * 350 for SW40, 50.
- ④ Obstacles at front only (Fig. 2-9)
 - * When using an optional air outlet guide, the clearance for SW100-200 models is 500 mm or more.
- ⑤ Obstacles at front and rear only (Fig. 2-10)
 - * When using an optional air outlet guide, the clearance for SW100-200 models is 500 mm or more.
- ⑥ Obstacles at rear, sides, and above only (Fig. 2-11)
 - * 350 for SW40, 50.
 - Do not install the optional air outlet guides for upward airflow.

2.4.3. When installing multiple outdoor units (Refer to the last page)

Leave 350 mm for SW40, 50 and 10 mm for SW75-120 and 50 mm for SW160, 200 space or more between the units.

The figures in parentheses are for SW100-200 models.

- ① Obstacles at rear only (Fig. 2-12)
- ② Obstacles at rear and above only (Fig. 2-13)
 - No more than 3 units must be installed side by side. In addition, leave space as shown.
 - Do not install the optional air outlet guides for upward airflow.
- ③ Obstacles at front only (Fig. 2-14)
 - * When using an optional air outlet guide, the clearance for SW100-200 models is 1000 mm or more.
- ④ Obstacles at front and rear only (Fig. 2-15)
 - * When using an optional air outlet guide, the clearance for SW100-200 models is 1000 mm or more.
- ⑤ Single parallel unit arrangement (Fig. 2-16)
 - * When using an optional air outlet guide installed for upward airflow, the clearance is 500 (1000) mm or more.
- ⑥ Multiple parallel unit arrangement (Fig. 2-17)
 - * When using an optional air outlet guide installed for upward airflow, the clearance is 1000 (1500) mm or more.
- ⑦ Stacked unit arrangement (Fig. 2-18)
 - The units can be stacked up to two units high.
 - No more than 2 stacked units must be installed side by side. In addition, leave space as shown.

3. Installing the outdoor unit

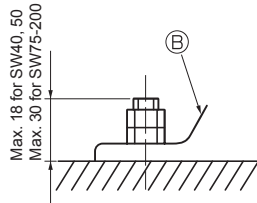
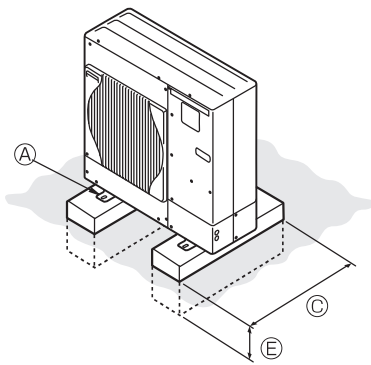

- A M10 (3/8") bolt
- B Base
- C As long as possible.
- D Vent
- E Set deep in the ground

(mm)

- Be sure to install the unit in a sturdy, level surface to prevent rattling noises during operation. (Fig. 3-1)

<Foundation specifications>

Foundation bolt	M10 (3/8")
Thickness of concrete	120 mm
Length of bolt	70 mm
Weight-bearing capacity	320 kg

- Make sure that the length of the foundation bolt is within 30 mm of the bottom surface of the base.
- Secure the base of the unit firmly with four-M10 foundation bolts in sturdy locations.

Installing the outdoor unit

- Do not block the vent. If the vent is blocked, operation will be hindered and breakdown may result.
- In addition to the unit base, use the installation holes on the back of the unit to attach wires, etc., if necessary to install the unit. Use self-tapping screws ($\phi 5 \times 15$ mm or less) and install on site.

Warning:

- The unit must be securely installed on a structure that can sustain its weight. If the unit is mounted on an unstable structure, it may fall down and cause damage or injuries.
- The unit must be installed according to the instructions in order to minimize the risk of damage from earthquakes, typhoons, or strong winds. An incorrectly installed unit may fall down and cause damage or injuries.

SW40, 50

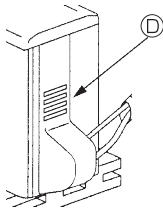

SW75-120

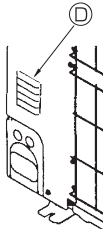

SW160, 200

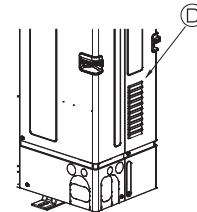

SW40, 50

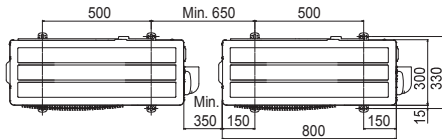

SW75-120

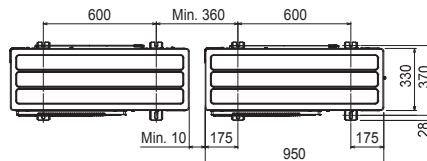
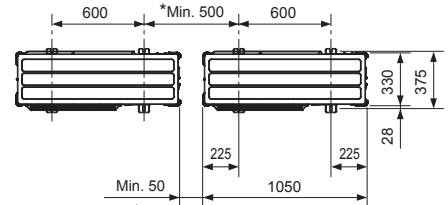

Fig. 3-1

SW160, 200



*When installing a single outdoor unit, the clearance is 15 mm or more.

4. Installing the refrigerant piping

4.1. Precautions for devices that use R410A refrigerant

- Refer to 1.5. for precautions not included below on using outdoor units with R410A refrigerant.
- Use ester oil, ether oil, alkylbenzene oil (small amount) as the refrigeration oil applied to the flared sections.
- Use C1220 copper phosphorus, for copper and copper alloy seamless pipes, to connect the refrigerant pipes. Use refrigerant pipes with the thicknesses specified in the table to the below. Make sure the insides of the pipes are clean and do not contain any harmful contaminants such as sulfuric compounds, oxidants, debris, or dust. Always apply no-oxidation brazing when brazing the pipes, otherwise, the compressor will be damaged.

Warning:

When installing or relocating, or servicing the outdoor unit, use only the specified refrigerant (R410A) to charge the refrigerant lines. Do not mix it with any other refrigerant and do not allow air to remain in the lines. If air is mixed with the refrigerant, then it can be the cause of abnormal high pressure in the refrigerant line, and may result in an explosion and other hazards.

The use of any refrigerant other than that specified for the system will cause mechanical failure or system malfunction or unit breakdown. In the worst case, this could lead to a serious impediment to securing product safety.

Pipe size (mm)	$\phi 6.35$	$\phi 9.52$	$\phi 12.7$	$\phi 15.88$	$\phi 19.05$	$\phi 22.2$	$\phi 25.4$	$\phi 28.58$
Thickness (mm)	0.8	0.8	0.8	1.0	1.0	1.0	1.0	1.0

- Do not use pipes thinner than those specified above.
- Use 1/2 H or H pipes if the diameter is 19.05 mm or larger.

4. Installing the refrigerant piping

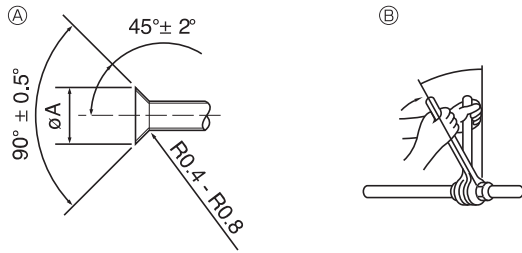

Ⓐ Flare cutting dimensions
Ⓑ Flare nut tightening torque

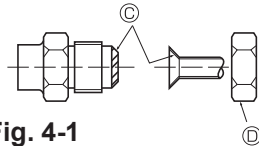

Fig. 4-1

Ⓐ (Fig. 4-1)

Copper pipe O.D. (mm)	Flare dimensions ϕA dimensions (mm)
$\phi 6.35$	8.7 - 9.1
$\phi 9.52$	12.8 - 13.2
$\phi 12.7$	16.2 - 16.6
$\phi 15.88$	19.3 - 19.7
$\phi 19.05$	23.6 - 24.0

Ⓑ (Fig. 4-1)

Copper pipe O.D. (mm)	Flare nut O.D. (mm)	Tightening torque (N·m)
$\phi 6.35$	17	14 - 18
$\phi 6.35$	22	34 - 42
$\phi 9.52$	22	34 - 42
$\phi 12.7$	26	49 - 61
$\phi 12.7$	29	68 - 82
$\phi 15.88$	29	68 - 82
$\phi 15.88$	36	100 - 120
$\phi 19.05$	36	100 - 120

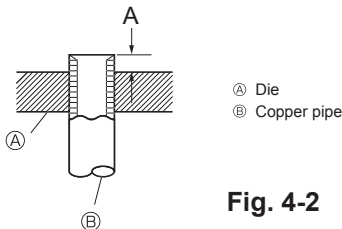
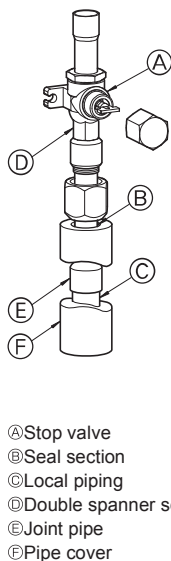
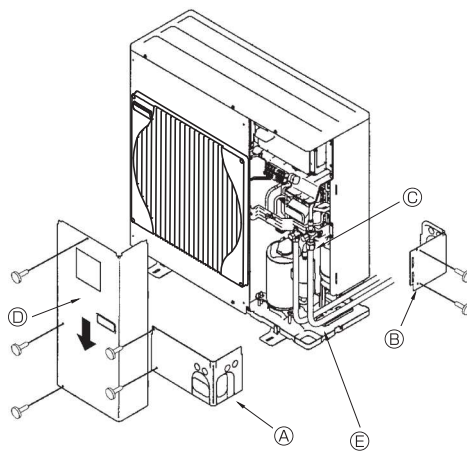

Fig. 4-2



Ⓐ Stop valve
Ⓑ Seal section
Ⓒ Local piping
Ⓓ Double spanner section
Ⓔ Joint pipe
Ⓕ Pipe cover

Fig. 4-3



Ⓐ Cover panel front
Ⓑ Cover panel rear
Ⓒ Stop valve
Ⓓ Service panel
Ⓔ Bend radius : 100 mm - 150 mm

Fig. 4-4

4.2. Connecting pipes (Fig. 4-1)

- When commercially available copper pipes are used, wrap liquid and gas pipes with commercially available insulation materials (heat-resistant to 100 °C or more, thickness of 12 mm or more). Direct contact with the bare piping may result in burns or frostbite.
- The indoor parts of the drain pipe should be wrapped with polyethylene foam insulation materials (specific gravity of 0.03, thickness of 9 mm or more).
- Apply thin layer of refrigerant oil to pipe and joint seating surface before tightening flare nut. Ⓐ
- Use two wrenches to tighten piping connections. Ⓑ
- Use leak detector or soapy water to check for gas leaks after connections are completed.
- Apply refrigerating machine oil over the entire flare seat surface. Ⓒ
- Use the flare nuts for the following pipe size. Ⓓ

	SW40, 50	SW75	SW100, 120	SW160	SW200
Gas side Pipe size (mm)	$\phi 12.7$	$\phi 15.88$	$\phi 15.88$	$\phi 25.4$	$\phi 25.4$
Liquid side Pipe size (mm)	$\phi 6.35$	$\phi 9.52$	$\phi 9.52$	$\phi 9.52$	$\phi 12.7$

- When bending the pipes, be careful not to break them. Bend radii of 100 mm to 150 mm are sufficient.
- Make sure the pipes do not contact the compressor. Abnormal noise or vibration may result.
- ① Pipes must be connected starting from the indoor unit. Flare nuts must be tightened with a torque wrench.
- ② Flare the liquid pipes and gas pipes and apply a thin layer of refrigeration oil (Applied on site).
- When usual pipe sealing is used, refer to Table 1 for flaring of R410A refrigerant pipes. The size adjustment gauge can be used to confirm A measurements.
- ③ Use the following procedure for connecting the gas-side piping. (Fig. 4-3) (SW160/200)
- 1 Braze the Ⓔ Joint pipe provided to the outdoor unit using locally procured brazing materials and Ⓒ Local piping without oxygen.
- 2 Connect the Ⓔ Joint pipe to the gas-side Stop valve. Use 2 wrenches to tighten the flare nut.
 - * If order is reversed, refrigerant leak occurs because of the part damaging by brazing fire.

Table 1 (Fig. 4-2)

Copper pipe O.D. (mm)	A (mm)	
	Flare tool for R410A	Flare tool for R22-R407C
	Clutch type	
$\phi 6.35$ (1/4")	0 - 0.5	1.0 - 1.5
$\phi 9.52$ (3/8")	0 - 0.5	1.0 - 1.5
$\phi 12.7$ (1/2")	0 - 0.5	1.0 - 1.5
$\phi 15.88$ (5/8")	0 - 0.5	1.0 - 1.5
$\phi 19.05$ (3/4")	0 - 0.5	1.0 - 1.5

⚠ Warning:

When installing the unit, securely connect the refrigerant pipes before starting the compressor.

4.3. Refrigerant piping (Fig. 4-4)

- For SW40, 50

Remove the service panel Ⓓ (1 screw).

- For SW75-200

Remove the service panel Ⓓ (3 screws: SW75-120 4 screws: SW160, 200) and the cover panel front Ⓐ (2 screws) and cover panel rear Ⓑ (2 screws: SW75-120) (4 screws: SW160, 200).

- Perform refrigerant piping connections for the indoor/outdoor unit when the outdoor unit's stop valve is completely closed.
- Vacuum-purge air from the indoor unit and the connection piping.
- After connecting the refrigerant pipes, check the connected pipes and the indoor unit for gas leaks. (Refer to 4.4 Refrigerant pipe airtight testing method)
- A high-performance vacuum pump is used at the stop valve service port to maintain a vacuum for an adequate time (at least one hour after reaching -101 kPa (5 Torr)) in order to vacuum dry the inside of the pipes. Always check the degree of vacuum at the gauge manifold. If there is any moisture left in the pipe, the degree of vacuum is sometimes not reached with short-time vacuum application. After vacuum drying, completely open the stop valves (both liquid and gas) for the outdoor unit. This completely links the indoor and outdoor refrigerant circuits.
 - If the vacuum drying is inadequate, air and water vapor remain in the refrigerant circuits and can cause abnormal rise of high pressure, abnormal drop of low pressure, deterioration of the refrigerating machine oil due to moisture, etc.
 - If the stop valves are left closed and the unit is operated, the compressor and control valves will be damaged.
- Use a leak detector or soapy water to check for gas leaks at the pipe connection sections of the outdoor unit.
- Do not use the refrigerant from the unit to purge air from the refrigerant lines.
- After the valve work is completed, tighten the valve caps to the correct torque: 20 to 25 N·m (200 to 250 kgf·cm).

Failure to replace and tighten the caps may result in refrigerant leakage. In addition, do not damage the insides of the valve caps as they act as a seal to prevent refrigerant leakage.

4. Installing the refrigerant piping

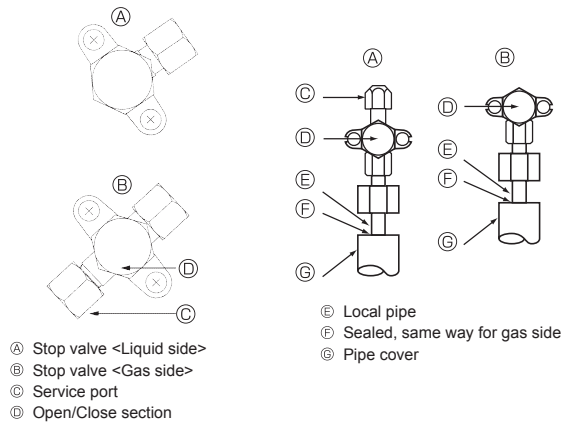

Fig. 4-5

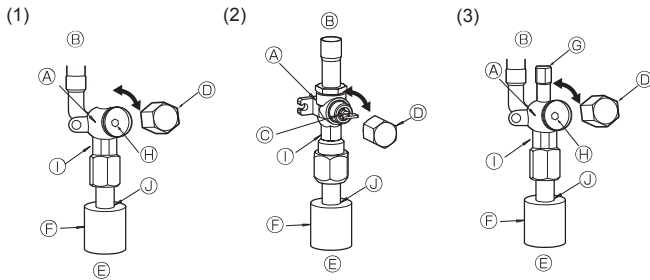

Fig. 4-6

Fig. 4-7

Fig. 4-8

- Ⓐ Valve
 Ⓑ Unit side
 Ⓒ Handle
 Ⓓ Cap
 Ⓔ Local pipe side
 Ⓕ Pipe cover
 Ⓖ Service port
 Ⓗ Wrench hole
 Ⓘ Double spanner section
 (Do not apply a spanner other than to this section.
 Doing so would cause coolant leaks.)
 Ⓙ Seal section
 (Seal the end of the heat insulation material at
 the pipe connection section with whatever seal
 material you have on hand so that water does not
 infiltrate the heat insulation material.)

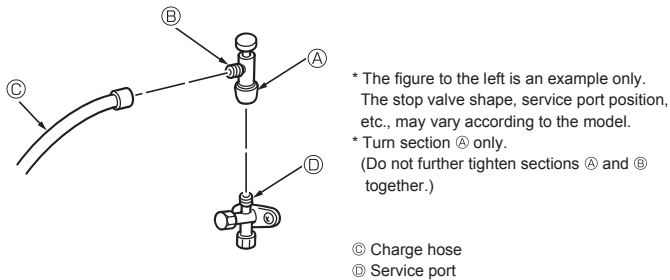

Fig. 4-9

4.4. Refrigerant pipe airtight testing method (Fig. 4-5)

- Connect the testing tools.
 - Make sure the stop valves Ⓐ Ⓑ are closed and do not open them.
 - Add pressure to the refrigerant lines through the service port Ⓒ of the liquid stop valve Ⓐ.
- Do not add pressure to the specified pressure all at once; add pressure little by little.
 - Pressurize to 0.5 MPa (5 kgf/cm²G), wait five minutes, and make sure the pressure does not decrease.
 - Pressurize to 1.5 MPa (15 kgf/cm²G), wait five minutes, and make sure the pressure does not decrease.
 - Pressurize to 4.15 MPa (41.5 kgf/cm²G) and measure the surrounding temperature and refrigerant pressure.
- If the specified pressure holds for about one day and does not decrease, the pipes have passed the test and there are no leaks.
 - If the surrounding temperature changes by 1 °C, the pressure will change by about 0.01 MPa (0.1 kgf/cm²G). Make the necessary corrections.
- If the pressure decreases in steps (2) or (3), there is a gas leak. Look for the source of the gas leak.

4.5. Stop valve opening method

The stop valve opening method varies according to the outdoor unit model. Use the appropriate method to open the stop valves.

- Gas side of SW75 (Fig. 4-6)
 - Remove the cap and turn the valve rod counter clock wise as far as it will go with the use of a 5 mm hexagonal wrench. Stop turning when it hits the stopper. (ø 15.88: Approximately 13 revolutions.)
 - Make sure that the stop valve is open completely and rotate the cap back to its original position.
- Gas side of SW100-200 (Fig. 4-7)
 - Remove the cap, pull the handle toward you and rotate 1/4 turn in a counter-clockwise direction to open.
 - Make sure that the stop valve is open completely, push in the handle and rotate the cap back to its original position.
- Liquid side of SW75-200 and Gas/Liquid side of SW40-75 (Fig. 4-8)
 - Remove the cap and turn the valve rod counterclockwise as far as it will go with the use of a 4 mm hexagonal wrench. Stop turning when it hits the stopper. (ø9.52: Approximately 10 revolutions)
 - Make sure that the stop valve is open completely, push in the handle and rotate the cap back to its original position.

Refrigerant pipes are protectively wrapped for SW75-200

- The pipes can be protectively wrapped up to a diameter of ø90 before or after connecting the pipes. Cut out the knockout in the pipe cover following the groove and wrap the pipes.

Pipe inlet gap for SW75-200

- Use putty or sealant to seal the pipe inlet around the pipes so that no gaps remain. (If the gaps are not closed, noise may be emitted or water and dust will enter the unit and breakdown may result.)

Precautions when using the charge valve (Fig. 4-9)

Do not tighten the service port too much when installing it, otherwise, the valve core could be deformed and become loose, causing a gas leak.

After positioning section Ⓑ in the desired direction, turn section Ⓐ only and tighten it. Do not further tighten sections Ⓐ and Ⓑ together after tightening section Ⓐ.

⚠ Warning:

When installing the unit, securely connect the refrigerant pipes before starting the compressor.

4. Installing the refrigerant piping

4.6. Addition of refrigerant

- Additional charging is not necessary if the pipe length does not exceed 10 m (SW40-120), 30 m (SW160, 200).
- If the pipe length exceeds 10 m (SW40-120), 30 m (SW160, 200), charge the unit with additional R410A refrigerant according to the permitted pipe lengths in the chart below.

* When the unit is stopped, charge the unit with the additional refrigerant through the liquid stop valve after the pipe extensions and indoor unit have been vacuumized.

When the unit is operating, add refrigerant to the gas check valve using a safety charger. Do not add liquid refrigerant directly to the check valve.

* After charging the unit with refrigerant, note the added refrigerant amount on the service label (attached to the unit).

Refer to the "1.5. Using R410A refrigerant outdoor unit" for more information.

- Be careful when installing multiple units. Connecting to an incorrect indoor unit can lead to abnormally high pressure and have a serious effect on operation performance.

Model	Permitted pipe length	Permitted vertical difference	Additional refrigerant charging amount					
			11 - 20 m	21 - 30 m	31 - 40 m	41 - 50 m	51 - 60 m	61 - 75 m
SW40, 50	2 m - 40 m	-10 m	0.2 kg	0.4 kg	0.6 kg	—	—	—
SW75	2 m - 40 m	-10 m	0.4 kg	0.8 kg	1.4 kg	—	—	—
SW100, 120	2 m - 75 m	-30 m	0.2 kg	0.4 kg	1.0 kg	1.6 kg	2.2 kg	2.8 kg

Model	Permitted pipe length	Permitted vertical difference	Additional refrigerant charging amount				
			31 - 40 m	41 - 50 m	51 - 60 m	61 - 70 m	71 - 80 m
SW160	2 m - 80 m	-30 m	0.9 kg	1.8 kg	2.7 kg	3.6 kg	Calculate the amount of additional refrigerant charge using formula
SW200	2 m - 80 m	-30 m	1.2 kg	2.4 kg	3.6 kg	4.8 kg	

When length exceeds 70 m

When the total length of the piping exceeds 70 m, calculate the amount of additional charge based on the following requirements.

Note: If the calculation produces a negative number (i.e. a "minus" charge), or if calculation results in an amount that is less than the "Additional charge amount for 70 m", perform the additional charge using the amount shown in "Additional charge amount for 70 m".

Amount of additional charge (kg)	=	Main piping: Liquid line size ø12.7 overall length × 0.11	+	Main piping: Liquid line size ø9.52 overall length × 0.09 (Gas line: ø25.4)	+	Branch piping: Liquid line size ø9.52 overall length × 0.06 (Gas line: ø15.88)	+	Branch piping: Liquid line size ø6.35 overall length × 0.02	-	3.6 (kg)
		(m) × 0.11 (kg/m)		(m) × 0.09 (kg/m)		(m) × 0.06 (kg/m)		(m) × 0.02 (kg/m)		

Additional charge amount for 70 meters	SW160	3.6 kg
	SW200	4.8 kg

4. Installing the refrigerant piping

4.7. Precautions when reusing existing R22 refrigerant pipes

- Refer to the flowchart below to determine if the existing pipes can be used and if it is necessary to use a filter dryer.
- If the diameter of the existing pipes is different from the specified diameter, refer to technological data materials to confirm if the pipes can be used.

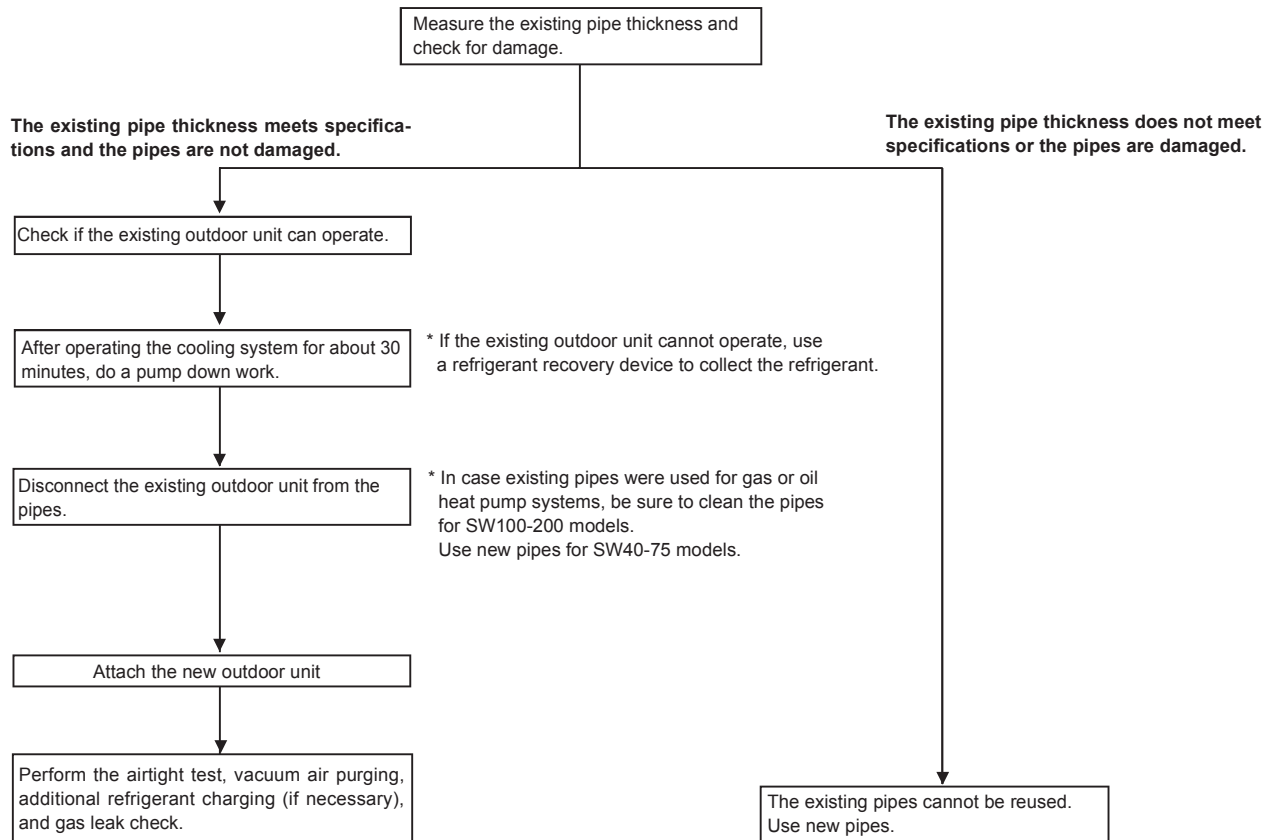

5. Drainage piping work

Outdoor unit drainage pipe connection

When drain piping is necessary, use the drain socket or the drain pan (option).

	SW40, 50	SW75	SW100, 120	SW160, 200
Drain socket	PAC-SG61DS-E			
Drain pan	PAC-SG63DP-E	PAC-SG64DP-E		PAC-SH97DP-E

6. Water piping work

Minimum water quantity

Following water quantity is required in the water circuit.

Model	Minimum water quantity (L)
SW40	30
SW50	40
SW75	60
SW100	80
SW120	120
SW160	160
SW200	200

7. Electrical work

7.1. Outdoor unit (Fig. 7-1, Fig. 7-2)

- ① Remove the service panel.
- ② Wire the cables referring to the Fig. 7-1 and the Fig. 7-2.

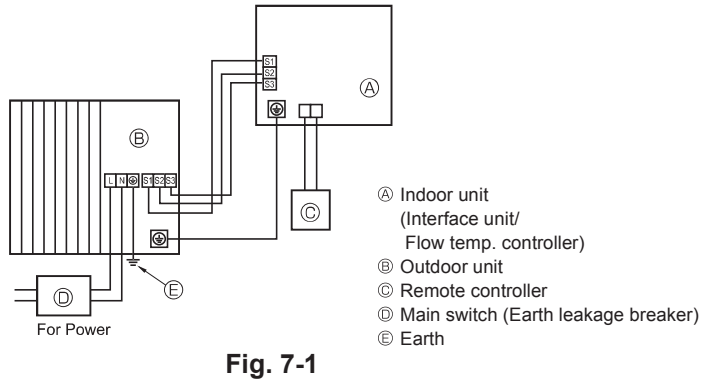

■ SW40, 50V

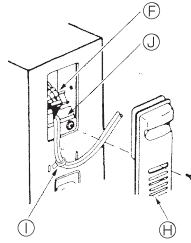

■ SW40, 50V

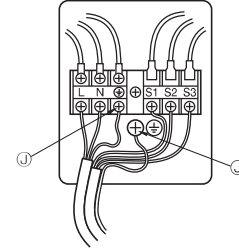

■ SW75-200

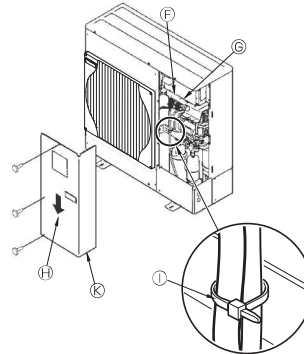

■ SW75-120V

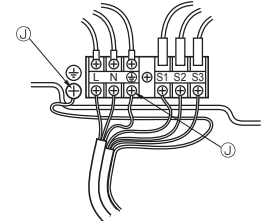

■ SW100-200Y

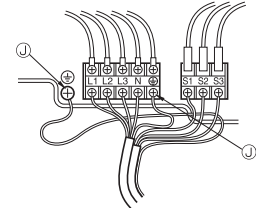

Fig. 7-2

- Ⓞ Terminal block
- Ⓞ Indoor/Outdoor connection terminal block (S1, S2, S3)
- Ⓞ Service panel
- Ⓞ Clamp
- * Clamp the cables so that they do not contact the center of the service panel or the gas valve.
- Ⓞ Earth terminal
- Ⓞ Wire the cables so that they do not contact the center of the service panel.

Note :
If the protective sheet for the electrical box is removed during servicing, be sure to reinstall it.

Caution:
Be sure to install N-Line. Without N-Line, it could cause damage to unit.

7.2. Field electrical wiring

Outdoor unit model	SW40, 50V	SW75V	SW100V	SW120V	SW100, 120Y	SW160, 200Y
Outdoor unit power supply	~N (single), 50 Hz, 230 V	~N (single), 50 Hz, 230 V	~N (single), 50 Hz, 230 V	~N (single), 50 Hz, 230 V	3N~ (3 ph 4-wires), 50 Hz, 400 V	3N~ (3 ph 4-wires), 50 Hz, 400 V
Outdoor unit input capacity Main switch (Breaker) *1	16 A	25 A	32 A	40 A	16 A	32 A
Outdoor unit power supply	3 × Min. 1.5	3 × Min. 2.5	3 × Min. 4	3 × Min. 6	5 × Min. 1.5	5 × Min. 1.5
Wiring Wire No. × size (mm ²)	Indoor unit-Outdoor unit	*2 3 × 1.5 (Polar)	3 × 1.5 (Polar)	3 × 1.5 (Polar)	3 × 1.5 (Polar)	Cable length 50m: 3×4 (Polar)/ Cable length 80m: 3×6 (Polar)
	Indoor unit-Outdoor unit earth	*2 1 × Min. 1.5	1 × Min. 1.5	1 × Min. 1.5	1 × Min. 1.5	1 × Min. 1.5
	Remote controller-Indoor unit	*3 2 × 0.3 (Non-polar)	2 × 0.3 (Non-polar)	2 × 0.3 (Non-polar)	2 × 0.3 (Non-polar)	2 × 0.3 (Non-polar)
Circuit rating	Outdoor unit L-N (single)					
	Outdoor unit L1-N, L2-N, L3-N (3 phase)	*4 AC 230 V	AC 230 V	AC 230 V	AC 230 V	AC 230 V
	Indoor unit-Outdoor unit S1-S2	*4 AC 230 V	AC 230 V	AC 230 V	AC 230 V	AC 230 V
	Indoor unit-Outdoor unit S2-S3	*4 DC 24 V	DC 24 V	DC 24 V	DC 24 V	DC 24 V
Remote controller-Indoor unit	*4 DC 12 V	DC 12 V	DC 12 V	DC 12 V	DC 12 V	DC 12 V

- *1. A breaker with at least 3.0 mm contact separation in each poles shall be provided. Use earth leakage breaker (NV).
Make sure that the current leakage breaker is one compatible with higher harmonics.
Always use a current leakage breaker that is compatible with higher harmonics as this unit is equipped with an inverter.
The use of an inadequate breaker can cause the incorrect operation of inverter.

- *2. (SW40-120)
Max. 45 m
If 2.5 mm² used, Max. 50 m
If 2.5 mm² used and S3 separated, Max. 80 m
(SW160, 200)
Max. 80 m Total Max. including all indoor/indoor connection is 80 m.



- * Use one cable for S1 and S2 and another for S3 as shown in the picture.
- *3. The 10 m wire is attached in the remote controller accessory.
- *4. The figures are NOT always against the ground.
S3 terminal has DC 24 V against S2 terminal. However between S3 and S1, these terminals are NOT electrically insulated by the transformer or other device.

7. Electrical work

- Notes:**
1. Wiring size must comply with the applicable local and national codes.
 2. Power supply cables and the cables between Interface unit/Flow temp. controller and outdoor unit shall not be lighter than polychloroprene sheathed flexible cables. (Design 60245 IEC 57)
 3. Be sure to connect the cables between Interface unit/Flow temp. controller and outdoor unit directly to the units (no intermediate connections are allowed).
Intermediate connections may result in communication errors. If water enters at the intermediate connection point, it may cause insufficient insulation to ground or a poor electrical contact.
(If an intermediate connection is necessary, be sure to take measures to prevent water from entering the cables.)
 4. Install an earth longer than other cables.
 5. Do not construct a system with a power supply that is turned ON and OFF frequently.

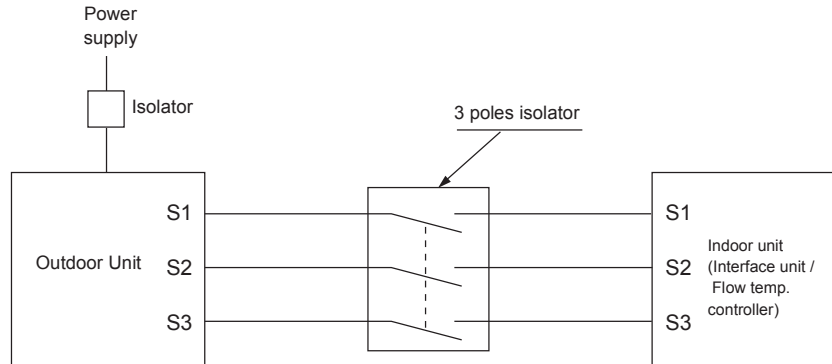





⚠ Warning:

- In case of A-control wiring, there is high voltage potential on the S3 terminal caused by electrical circuit design that has no electrical insulation between power line and communication signal line. Therefore, please turn off the main power supply when servicing. And do not touch the S1, S2, S3 terminals when the power is energized. If isolator should be used between indoor unit and outdoor unit, please use 3-pole type.

Never splice the power cable or the indoor-outdoor connection cable, otherwise it may result in a smoke, a fire or communication failure.

INDOOR-OUTDOOR CONNECTING CABLE (SW160, 200)

Cross section of cable	Wire size (mm ²)	Number of wires	Polarity	L (m)*6
Round 	2.5	3	Clockwise : S1-S2-S3 *Pay attention to stripe of yellow and green	(30) *2
Flat 	2.5	3	Not applicable (Because center wire has no cover finish)	Not applicable *5
Flat 	1.5	4	From left to right : S1-Open-S2-S3	(18) *3
Round 	2.5	4	Clockwise : S1-S2-S3-Open *Connect S1 and S3 to the opposite angle	(30) *4

*1 :Power supply cords of appliances shall not be lighter than design 60245 IEC or 227 IEC.

*2 :In case that cable with stripe of yellow and green is available.

*3 :In case of regular polarity connection (S1-S2-S3), wire size is 1.5 mm².

*4 :In case of regular polarity connection (S1-S2-S3).

*5 :In the flat cables are connected as this picture, they can be used up to 30 m.



*6 :Mentioned cable length is just a reference value.

It may be different depending on the condition of installation, humidity or materials, etc.

7.3. Breaker size setting (only for SW75)

The breaker size can be changed with DIP switches SW7-4,5 on the Control board.

SW7		Breaker size	
4	5	Both for indoor unit and outdoor unit	Only for outdoor unit
OFF	OFF	25A (Default)	20A
OFF	ON	20A	16A
ON	ON	16A	—

*1. Execute setting with the power of the unit OFF. The setting becomes valid when power is restored.

*2. Capacity restrictions may apply when operating under a high-load with a reduced breaker size.

8. Special Functions

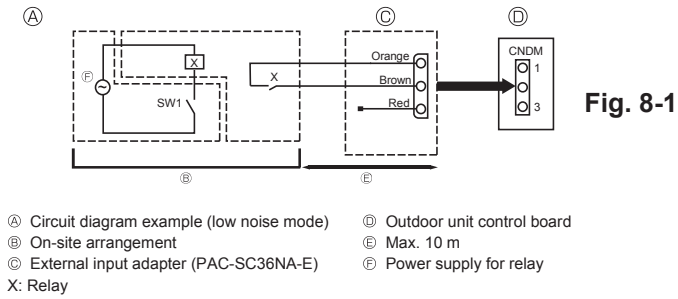

8.1. Low noise mode (on-site modification) (Fig. 8-1)

By performing the following modification, operation noise of the outdoor unit can be reduced by about 3-4 dB.

The low noise mode will be activated when a commercially available timer or the contact input of an ON/OFF switch is added to the CNDM connector (option) on the control board of the outdoor unit.

- The ability varies according to the outdoor temperature and conditions, etc.

① Complete the circuit as shown when using the external input adapter (PAC-SC36NA-E). (Option)

② SW7-1 (Outdoor unit control board): OFF

③ SW1 ON: Low noise mode
SW1 OFF: Normal operation

8.2. Refrigerant collecting (pump down)

Perform the following procedures to collect the refrigerant when moving the indoor unit or the outdoor unit.

① Supply power (circuit breaker).

- When power is supplied, make sure that "CENTRALLY CONTROLLED" is not displayed on the remote controller. If "CENTRALLY CONTROLLED" is displayed, the refrigerant collecting (pump down) cannot be completed normally.

- Start-up of the indoor-outdoor communication takes about 3 minutes after the power (circuit breaker) is turned on. Start the pump-down operation 3 to 4 minutes after the power (circuit breaker) is turned ON.

- In the case of multi-units control, before powering on, disconnect the wiring between the master indoor unit and the slave indoor unit. For more details refer to the installation manual for the indoor unit.

② After the liquid stop valve is closed, set the SWP switch on the control board of the outdoor unit to ON. The compressor (outdoor unit) and ventilators (indoor and outdoor units) start operating and refrigerant collecting operation begins. LED1 and LED2 on the control board of the outdoor unit are lit.

- Only set the SWP switch (push-button type) to ON if the unit is stopped. However, even if the unit is stopped and the SWP switch is set to ON less than 3 minutes after the compressor stops, the refrigerant collecting operation cannot be performed. Wait until compressor has been stopped for 3 minutes and then set the SWP switch to ON again.

③ Because the unit automatically stops in about 2 to 3 minutes when the refrigerant collecting operation is completed (LED1 off, LED2 lit), be sure to quickly close the gas stop valve. If LED1 is lit and LED2 is off and the outdoor unit is stopped, refrigerant collection is not properly performed. Open the liquid stop valve completely, and then repeat step ② after 3 minutes have passed.

- If the refrigerant collecting operation has been completed normally (LED1 off, LED2 lit), the unit will remain stopped until the power supply is turned off.

④ Turn off the power supply (circuit breaker).

- Note that when the extension piping is very long with large refrigerant amount, it may not be possible to perform a pump-down operation. When performing the pump-down operation, make sure that the low pressure is lowered to near 0 MPa (gauge).

⚠ Warning:

When pumping down the refrigerant, stop the compressor before disconnecting the refrigerant pipes. The compressor may burst if air etc. get into it.

9. System control

Set the refrigerant address using the DIP switch of the outdoor unit.

SW1 Function Setting

SW1 Setting	Refrigerant address	SW1 Setting	Refrigerant address
ON OFF 3 4 5 6 7	00	ON OFF 3 4 5 6 7	03
ON OFF 3 4 5 6 7	01	ON OFF 3 4 5 6 7	04
ON OFF 3 4 5 6 7	02	ON OFF 3 4 5 6 7	05

Note:

a) Up to 6 units can be connected.

b) Select one single model for all units.

c) For Dip switch setting for indoor unit, refer to the indoor unit's installation manual.

10. Specifications

			SW40	SW50	SW75	SW100	SW120	SW160	SW200
Sound level (Measured under rated operating frequency)									
SPL	Heating	dB(A)	45	46	51	54	54	62	62
	Cooling	dB(A)	45	46	48	50	51	58	60
PWL	Heating	dB(A)	62	63	69	70	72	78	78