

SERVICE MANUAL R410A

[Model Name]

PUHZ-SHW80VAA
 PUHZ-SHW112VAA
 PUHZ-SHW80YAA
 PUHZ-SHW112YAA
 PUHZ-SW75VAA
 PUHZ-SW100VAA
 PUHZ-SW75YAA
 PUHZ-SW100YAA
 PUHZ-SW75VAA-SC
 PUHZ-SW75YAA-SC

Salt proof model

PUHZ-SHW80VAA-BS
 PUHZ-SHW112VAA-BS
 PUHZ-SHW80YAA-BS
 PUHZ-SHW112YAA-BS
 PUHZ-SW75VAA-BS
 PUHZ-SW100VAA-BS
 PUHZ-SW75YAA-BS
 PUHZ-SW100YAA-BS

[Service Ref.]

PUHZ-SHW80VAA.UK
 PUHZ-SHW112VAA.UK
 PUHZ-SHW80YAA.UK
 PUHZ-SHW112YAA.UK
 PUHZ-SW75VAA.UK
 PUHZ-SW100VAA.UK
 PUHZ-SW75YAA.UK
 PUHZ-SW100YAA.UK
 PUHZ-SW75VAA-SC.UK
 PUHZ-SW75YAA-SC.UK

PUHZ-SHW80VAA-BS.UK
 PUHZ-SHW112VAA-BS.UK
 PUHZ-SHW80YAA-BS.UK
 PUHZ-SHW112YAA-BS.UK
 PUHZ-SW75VAA-BS.UK
 PUHZ-SW100VAA-BS.UK
 PUHZ-SW75YAA-BS.UK
 PUHZ-SW100YAA-BS.UK

Revision:

- Added
 PUHZ-SW75VAA-SC.UK and
 PUHZ-SW75YAA-SC.UK
 in REVISED EDITION-A.
- Some descriptions have
 been modified.

- OCH651 is void.

Note:

- This manual describes
 service data of the outdoor
 units only.

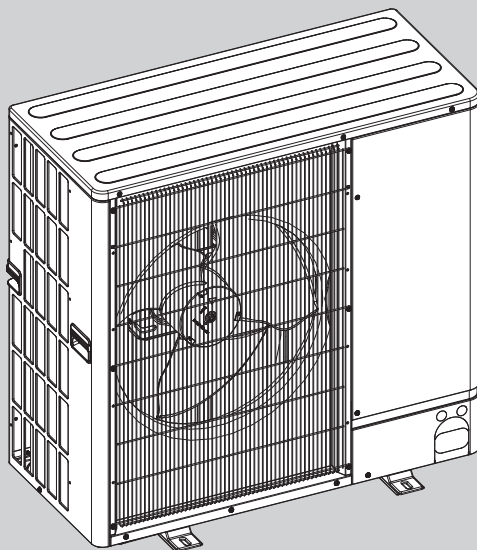

CONTENTS

1. REFERENCE MANUAL.....	2
2. SAFETY PRECAUTION	3
3. SPECIFICATIONS	7
4. DATA	10
5. OUTLINES AND DIMENSIONS.....	12
6. WIRING DIAGRAM.....	13
7. WIRING SPECIFICATIONS	17
8. REFRIGERANT SYSTEM DIAGRAM	18
9. TROUBLESHOOTING	21
10. MONITORING THE OPERATION DATA BY THE REMOTE CONTROLLER	60
11. DISASSEMBLY PROCEDURE	66

PARTS CATALOG (OCB651)

INDOOR UNIT SERVICE MANUAL

1-1. FOR AIR TO WATER SYSTEM

Model name	Service ref.	Service manual No.
EHST20C-VM6HB EHST20C-YM9HB EHST20C-TM9HB EHST20C-VM2B EHST20C-VM6B EHST20C-YM9B EHST20C-VM6EB EHST20C-YM9EB EHST20C-VM6SB	EHST20C-VM6HB.UK EHST20C-YM9HB.UK EHST20C-TM9HB.UK EHST20C-VM2B.UK EHST20C-VM6B.UK EHST20C-YM9B.UK EHST20C-VM6EB.UK EHST20C-YM9EB.UK EHST20C-VM6SB.UK	OCH531 OCB531
EHSC-VM2B EHSC-VM6B EHSC-YM9B EHSC-TM9B EHSC-VM6EB EHSC-YM9EB ERSC-VM2B	EHSC-VM2B.UK EHSC-VM6B.UK EHSC-YM9B.UK EHSC-TM9B.UK EHSC-VM6EB.UK EHSC-YM9EB.UK ERSC-VM2B.UK	OCH532 OCB532
EHSC-MEC EHSC-VM2C EHSC-VM2EC EHSC-VM6C EHSC-VM6EC EHSC-YM9C EHSC-YM9EC EHSC-TM9C EHSD-MC EHSD-MEC EHSD-VM2C EHSD-YM9C ERSC-MEC ERSC-VM2C ERSD-VM2C	EHSC-MECR2.UK EHSC-VM2CR2.UK EHSC-VM2ECR2.UK EHSC-VM6CR2.UK EHSC-VM6ECR2.UK EHSC-YM9CR2.UK EHSC-YM9ECR2.UK EHSC-TM9CR2.UK EHSD-MCR2.UK EHSD-MECR2.UK EHSD-VM2CR2.UK EHSD-YM9CR2.UK ERSC-MECR2.UK ERSC-VM2CR2.UK ERSD-VM2CR2.UK	OCH571 OCB571
EHST20C-VM2C EHST20C-VM6C EHST20C-YM9C EHST20C-TM9C EHST20C-VM2EC EHST20C-VM6EC EHST20C-YM9EC EHST20C-MHCW EHST20C-MEC EHST20D-VM2C EHST20D-VM2EC EHST20D-YM9C EHST20D-MHCW EHST20D-MEC EHST20D-MHC ERST20C-VM2C ERST20C-MEC ERST20D-VM2C ERST20D-MEC	EHST20C-VM2CR2.UK EHST20C-VM6CR2.UK EHST20C-YM9CR2.UK EHST20C-TM9CR2.UK EHST20C-VM2ECR2.UK EHST20C-VM6ECR2.UK EHST20C-YM9ECR2.UK EHST20C-MHCWR2.UK EHST20C-MECR2.UK EHST20D-VM2CR2.UK EHST20D-VM2ECR2.UK EHST20D-YM9CR2.UK EHST20D-MHCWR2.UK EHST20D-MECR2.UK EHST20D-MHCR2.UK ERST20C-VM2CR2.UK ERST20C-MECR2.UK ERST20D-VM2CR2.UK ERST20D-MECR2.UK	OCH570 OCB570
PAC-IF011B-E PAC-IF032B-E	PAC-IF011B-E PAC-IF032B-E	OCB427
PAC-IF061B-E	PAC-IF061B-ER2	OCB572
PAC-SIF051B-E	PAC-SIF051B-ER2	OCB536

2-1. ALWAYS OBSERVE FOR SAFETY

Before obtaining access to terminal, all supply circuits must be disconnected.

Preparation before the repair service.

- Prepare the proper tools.
- Prepare the proper protectors.
- Provide adequate ventilation.
- After stopping the operation of the heat pump units, turn off the power-supply breaker.
- Discharge the condenser before the work involving the electric parts.

Precautions during the repair service.

- Do not perform the work involving the electric parts with wet hands.
- Do not pour water into the electric parts.
- Do not touch the refrigerant.
- Do not touch the hot or cold areas in the refrigerating cycle.
- When the repair or the inspection of the circuit needs to be done without turning off the power, exercise great caution not to touch the live parts.

2-2. CAUTIONS RELATED TO NEW REFRIGERANT

Cautions for units utilizing refrigerant R410A

Use new refrigerant pipes.

In case of using the existing pipes for R22, be careful with the following:

- Be sure to perform replacement operation before test run.
- Change flare nut to the one provided with this product. Use a newly flared pipe.
- Avoid using thin pipes.

Make sure that the inside and outside of refrigerant piping is clean and it has no contaminants such as sulfur, oxides, dirt, shaving particles, etc, which are hazard to refrigerant cycle. In addition, use pipes with specified thickness.

Contamination inside refrigerant piping can cause deterioration of refrigerant oil, etc.

Store the piping indoors, and both ends of the piping sealed until just before brazing. (Leave elbow joints, etc. in their packaging.)

If dirt, dust or moisture enters into refrigerant cycle, that can cause deterioration of refrigerant oil or malfunction of compressor.

The refrigerant oil applied to flare and flange connections must be ester oil, ether oil or alkylbenzene oil in a small amount.

If large amount of mineral oil enters, that can cause deterioration of refrigerant oil, etc.

Charge refrigerant from liquid phase of gas cylinder.

If the refrigerant is charged from gas phase, composition change may occur in refrigerant and the efficiency will be lowered.

Do not use refrigerant other than R410A.

If other refrigerant (R22, etc.) is used, chlorine in refrigerant can cause deterioration of refrigerant oil, etc.

Use a vacuum pump with a reverse flow check valve.

Vacuum pump oil may flow back into refrigerant cycle and that can cause deterioration of refrigerant oil, etc.

Use the following tools specifically designed for use with R410A refrigerant.

The following tools are necessary to use R410A refrigerant.

Tools for R410A	
Gauge manifold	Flare tool
Charge hose	Size adjustment gauge
Gas leak detector	Vacuum pump adaptor
Torque wrench	Electronic refrigerant charging scale

Handle tools with care.

If dirt, dust or moisture enters into refrigerant cycle, that can cause deterioration of refrigerant oil or malfunction of compressor.

Do not use a charging cylinder.

If a charging cylinder is used, the composition of refrigerant will change and the efficiency will be lowered.

Ventilate the room if refrigerant leaks during operation. If refrigerant comes into contact with a flame, poisonous gases will be released.

Use the specified refrigerant only.

Never use any refrigerant other than that specified.

Doing so may cause a burst, an explosion, or fire when the unit is being used, serviced, or disposed of.

Correct refrigerant is specified in the manuals and on the spec labels provided with our products.

We will not be held responsible for mechanical failure, system malfunction, unit breakdown or accidents caused by failure to follow the instructions.

[1] Cautions for service

- (1) Perform service after recovering the refrigerant left in unit completely.
- (2) Do not release refrigerant in the air.
- (3) After completing service, charge the cycle with specified amount of refrigerant.
- (4) If moisture or foreign matter might have entered the refrigerant piping during service, ensure to remove them.

[2] Additional refrigerant charge

When charging directly from cylinder

- (1) Check that cylinder for R410A on the market is a syphon type.
- (2) Charging should be performed with the cylinder of syphon stood vertically. (Refrigerant is charged from liquid phase.)

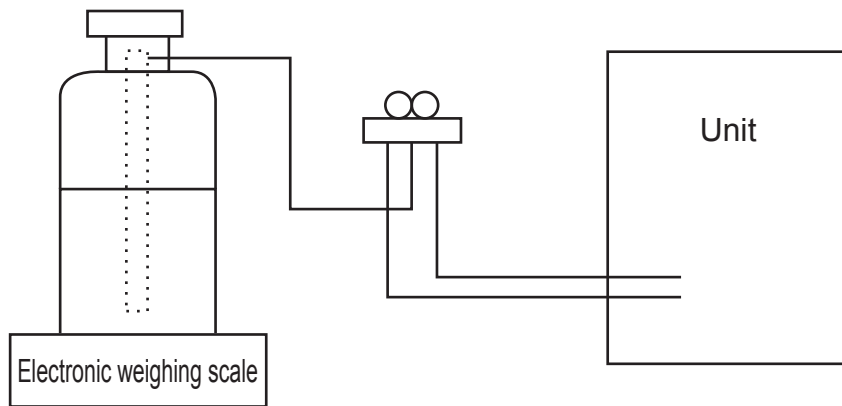

[3] Service tools

Use the below service tools as exclusive tools for R410A refrigerant.

No.	Tool name	Specifications
①	Gauge manifold	· Only for R410A
		· Use the existing fitting specifications. (UNF1/2)
		· Use high-tension side pressure of 5.3 MPa·G or over.
②	Charge hose	· Only for R410A
		· Use pressure performance of 5.09 MPa·G or over.
③	Electronic weighing scale	—
④	Gas leak detector	· Use the detector for R134a, R407C or R410A.
⑤	Adaptor for reverse flow check	· Attach on vacuum pump.
⑥	Refrigerant charge base	—
⑦	Refrigerant cylinder	· Only for R410A · Top of cylinder (Pink)
		· Cylinder with syphon
⑧	Refrigerant recovery equipment	—

2-3. PRECAUTIONS WHEN REUSING EXISTING R22 REFRIGERANT PIPES

Flowchart

- Refer to the flowchart below to determine if the existing pipes can be used and if it is necessary to use a filter dryer.
- If the diameter of the existing pipes is different from the specified diameter, refer to technological data materials to confirm if the pipes can be used.

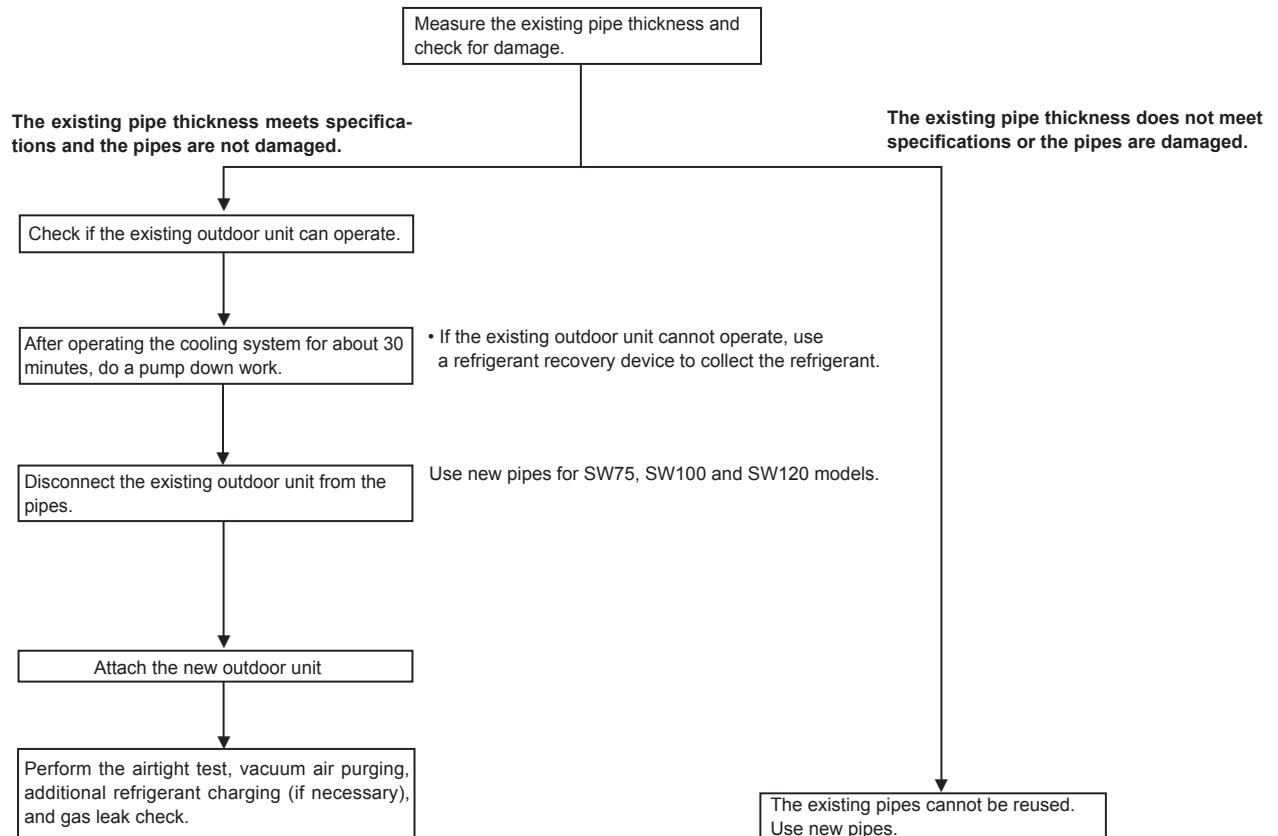

2-4. PRECAUTIONS FOR SALT PROOF TYPE "-BS" MODEL

Although "-BS" model has been designed to be resistant to salt damage, observe the following precautions to maintain the performance of the unit.

- (1) Avoid installing the unit in a location where it will be exposed directly to seawater or sea breeze.
- (2) If the cover panel may become covered with salt, be sure to install the unit in a location where the salt will be washed away by rainwater. (If a sunshade is installed, rainwater may not clean the panel.)
- (3) To ensure that water does not collect in the base of the outdoor unit, make sure that the base is level, not at angle. Water collecting in the base of the outdoor unit could cause rust.
- (4) If the unit is installed in a coastal area, clean the unit with water regularly to remove any salt build-up.
- (5) If the unit is damaged during installation or maintenance, be sure to repair it.
- (6) Be sure to check the condition of the unit regularly.
- (7) Be sure to install the unit in a location with good drainage.

Cautions for refrigerant piping work

New refrigerant R410A is adopted for replacement inverter series. Although the refrigerant piping work for R410A is same as for R22, exclusive tools are necessary so as not to mix with different kind of refrigerant. Furthermore as the working pressure of R410A is 1.6 times higher than that of R22, their sizes of flared sections and flare nuts are different.

① Thickness of pipes

Because the working pressure of R410A is higher compared to R22, be sure to use refrigerant piping with thickness shown below. (Never use pipes of 0.7 mm or below.)

Diagram below: Piping diameter and thickness

Nominal dimensions(inch)	Outside diameter (mm)	Thickness (mm)	
		R410A	R22
1/4	6.35	0.8	0.8
3/8	9.52	0.8	0.8
1/2	12.70	0.8	0.8
5/8	15.88	1.0	1.0
3/4	19.05	—	1.0

② Dimensions of flare cutting and flare nut

The component molecules in HFC refrigerant are smaller compared to conventional refrigerants. In addition to that, R410A is a refrigerant, which has higher risk of leakage because its working pressure is higher than that of other refrigerants. Therefore, to enhance airtightness and strength, flare cutting dimension of copper pipe for R410A has been specified separately from the dimensions for other refrigerants as shown below. The dimension B of flare nut for R410A also has partly been changed to increase strength as shown below. Set copper pipe correctly referring to copper pipe flaring dimensions for R410A below. For 1/2 and 5/8 inch pipes, the dimension B changes.

Use torque wrench corresponding to each dimension.

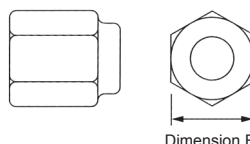
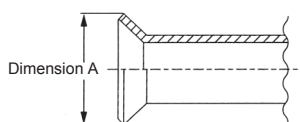

Flare cutting dimensions

Nominal dimensions(in)	Outside diameter (mm)	Dimension A ($^{+0}_{-0.4}$) (mm)	
		R410A	R22
1/4	6.35	9.1	9.0
3/8	9.52	13.2	13.0
1/2	12.70	16.6	16.2
5/8	15.88	19.7	19.4
3/4	19.05	—	23.3

Flare nut dimensions

Nominal dimensions(in)	Outside diameter (mm)	Dimension B (mm)	
		R410A	R22
1/4	6.35	17.0	17.0
3/8	9.52	22.0	22.0
1/2	12.70	26.0	24.0
5/8	15.88	29.0 *	27.0
3/4	19.05	-	36.0

* 36.0mm for indoor unit of RP100, 125 and 140

③ Tools for R410A (The following table shows whether conventional tools can be used or not.)

Tools and materials	Use	R410A tools	Can R22 tools be used?	Can R407C tools be used?
Gauge manifold	Air purge, refrigerant charge and operation check	Tool exclusive for R410A	×	×
Charge hose		Tool exclusive for R410A	×	×
Gas leak detector	Gas leak check	Tool for HFC refrigerant	×	○
Refrigerant recovery equipment	Refrigerant recovery	Tool exclusive for R410A	×	×
Refrigerant cylinder	Refrigerant charge	Tool exclusive for R410A	×	×
Applied oil	Apply to flared section	Ester oil, ether oil and alkylbenzene oil (minimum amount)	×	Ester oil, ether oil: ○ Alkylbenzene oil: minimum amount
Safety charger	Prevent compressor malfunction when charging refrigerant by spraying liquid refrigerant	Tool exclusive for R410A	×	×
Charge valve	Prevent gas from blowing out when detaching charge hose	Tool exclusive for R410A	×	×
Vacuum pump	Vacuum drying and air purge	Tools for other refrigerants can be used if equipped with adapter for reverse flow check	△ (Usable if equipped with adapter for reverse flow)	△ (Usable if equipped with adapter for reverse flow)
Flare tool	Flaring work of piping	Tools for other refrigerants can be used by adjusting flaring dimension	△ (Usable by adjusting flaring dimension)	△ (Usable by adjusting flaring dimension)
Bender	Bend the pipes	Tools for other refrigerants can be used	○	○
Pipe cutter	Cut the pipes	Tools for other refrigerants can be used	○	○
Welder and nitrogen gas cylinder	Weld the pipes	Tools for other refrigerants can be used	○	○
Refrigerant charging scale	Charge refrigerant	Tools for other refrigerants can be used	○	○
Vacuum gauge or thermistor vacuum gauge and vacuum valve	Check the degree of vacuum. (Vacuum valve prevents back flow of oil and refrigerant to thermistor vacuum gauge)	Tools for other refrigerants can be used	○	○
Charging cylinder	Refrigerant charge	Tool exclusive for R410A	×	—

× : Prepare a new tool. (Use the new tool as the tool exclusive for R410A.)

△ : Tools for other refrigerants can be used under certain conditions.

○ : Tools for other refrigerants can be used.

3

SPECIFICATIONS

Service Ref.			PUHZ-SHW80VAA(-BS).UK	PUHZ-SHW80YAA(-BS).UK	
OUTDOOR UNIT	Power source (Phase, cycle, voltage)		Single 50 Hz, 230 V	3-Phase 50 Hz, 400 V	
	Max. current	A	22.0	13.0	
	External finish		Munsell: N8.75 Munsell N2.75 (FRONT PANEL)		
	Refrigerant control		Linear Expansion Valve		
	Compressor		Hermetic		
		Model		DNK28FBAMT	DNK28FBBMT
		Motor output	kW	2.2	
		Starter type		Inverter	
		Protection devices		HP switch, LP switch Discharge thermo, Overcurrent detection, Comp. surface thermo	
	Crankcase heater		W	—	
	Heat exchanger		Plate fin coil		
	Fan	Fan (drive) × No.		Propeller fan x 1	
		Fan motor output	kW	0.2	
		Air flow	m ³ /min (CFM)	50 (1,760)	
	Defrost method		Reverse cycle		
	Sound power level	Heating	dB	59	59
	Dimensions	W	mm (inch)	1020 (40-3/16)	
		D	mm (inch)	480 (18-7/8)	
		H	mm (inch)	1050 (41-5/16)	
	Weight		kg (lb)	116 (256)	128 (282)
Refrigerant		R410A			
	Charge	kg (lb)	4.6 (10.1)		
	Oil (Model)	L	1.00 (FVC68D)		
Refrigerant piping	Pipe size OD	Liquid	mm (inch)	9.52 (3/8)	
		Gas	mm (inch)	15.88 (5/8)	
Connection method	Indoor side		Flared		
	Outdoor side		Flared		
Between the indoor & outdoor	Height difference		Maximum 30 m		
	Piping length		2 to 75 m		

Service Ref.			PUHZ-SHW112VAA(-BS).UK	PUHZ-SHW112YAA(-BS).UK	
OUTDOOR UNIT	Power source (Phase, cycle, voltage)		Single 50 Hz, 230 V	3-Phase 50 Hz, 400 V	
	Max. current	A	28.0	13.0	
	External finish		Munsell: N8.75 Munsell N2.75 (FRONT PANEL)		
	Refrigerant control		Linear Expansion Valve		
	Compressor		Hermetic		
		Model		DNK28FBAMT	DNK28FBBMT
		Motor output	kW	2.2	
		Starter type		Inverter	
		Protection devices		HP switch, LP switch Discharge thermo, Overcurrent detection, Comp. surface thermo	
	Crankcase heater		W	—	
	Heat exchanger		Plate fin coil		
	Fan	Fan (drive) × No.		Propeller fan x 1	
		Fan motor output	kW	0.2	
		Air flow	m ³ /min (CFM)	50 (1,760)	
	Defrost method		Reverse cycle		
	Sound power level	Heating	dB	60	60
	Dimensions	W	mm (inch)	1020 (40-3/16)	
		D	mm (inch)	480 (18-7/8)	
		H	mm (inch)	1050 (41-5/16)	
	Weight		kg (lb)	116 (256)	128 (282)
Refrigerant		R410A			
	Charge	kg (lb)	4.6 (10.1)		
	Oil (Model)	L	1.00 (FVC68D)		
Refrigerant piping	Pipe size OD	Liquid	mm (inch)	9.52 (3/8)	
		Gas	mm (inch)	15.88 (5/8)	
Connection method	Indoor side		Flared		
	Outdoor side		Flared		
Between the indoor & outdoor	Height difference		Maximum 30 m		
	Piping length		2 to 75 m		



Service Ref.			PUHZ-SW75VAA(-BS).UK	PUHZ-SW75YAA(-BS).UK	
OUTDOOR UNIT	Power source (Phase, cycle, voltage)		Single, 50Hz, 230V	3-Phase 50 Hz, 400 V	
	Max. current	A	22.0	11.5	
	External finish		Munsell: N8.75 Munsell N2.75 (FRONT PANEL)		
	Refrigerant control		Linear Expansion Valve		
	Compressor		Hermetic		
		Model		SNB220FEGMC-L1	SNB220FEAMC-L1
		Motor output	kW	1.5	
		Starter type		Inverter	
		Protection devices		HP switch, Comp. surface thermo Discharge thermo, Over current detection	
	Crankcase heater		W	—	
	Heat exchanger		Plate fin coil		
	Fan	Fan (drive) × No.		Propeller fan x 1	
		Fan motor output	kW	0.074	
		Air flow	m³/min (CFM)	44(1,550)	
	Defrost method		Reverse cycle		
	Sound power level	Heating	dB	58	58
	Dimensions	W	mm (inch)	1020 (40-3/16)	
		D	mm (inch)	480 (18-7/8)	
		H	mm (inch)	1050 (41-5/16)	
	Weight		kg (lb)	92 (203)	104 (229)
Refrigerant		R410A			
	Charge	kg (lb)	3.0 (6.6)		
	Oil (Model)	L	0.60(FV50S)		
Pipe size OD	Liquid	mm (inch)	9.52(3/8)		
	Gas	mm (inch)	15.88(5/8)		
Connection method	Indoor side		Flared		
	Outdoor side		Flared		
Between the indoor & outdoor	Height difference		Maximum 30 m		
	Piping length		2 to 40 m		

Service Ref.			PUHZ-SW100VAA(-BS).UK	PUHZ-SW100YAA(-BS).UK	
OUTDOOR UNIT	Power source (Phase, cycle, voltage)		Single, 50Hz, 230V	3-Phase 50 Hz, 400 V	
	Max. current	A	28.0	13.0	
	External finish		Munsell: N8.75 Munsell N2.75 (FRONT PANEL)		
	Refrigerant control		Linear Expansion Valve		
	Compressor		Hermetic		
		Model		DNB28FBAMT	DNB28FBBMT
		Motor output	kW	2.2	
		Starter type		Inverter	
		Protection devices		HP switch, LP switch, Comp. surface thermo Discharge thermo, Over current detection	
	Crankcase heater		W	—	
	Heat exchanger		Plate fin coil		
	Fan	Fan (drive) × No.		Propeller fan x 1	
		Fan motor output	kW	0.2	
		Air flow	m³/min (CFM)	50 (1,760)	
	Defrost method		Reverse cycle		
	Sound power level	Heating	dB	60	60
	Dimensions	W	mm (inch)	1020 (40-3/16)	
		D	mm (inch)	480 (18-7/8)	
		H	mm (inch)	1050 (41-5/16)	
	Weight		kg (lb)	114 (251)	126 (278)
Refrigerant		R410A			
	Charge	kg (lb)	4.2 (9.2)		
	Oil (Model)	L	1.0 (FVC68D)		
Pipe size OD	Liquid	mm (inch)	9.52(3/8)		
	Gas	mm (inch)	15.88(5/8)		
Connection method	Indoor side		Flared		
	Outdoor side		Flared		
Between the indoor & outdoor	Height difference		Maximum 30 m		
	Piping length		2 to 75 m		

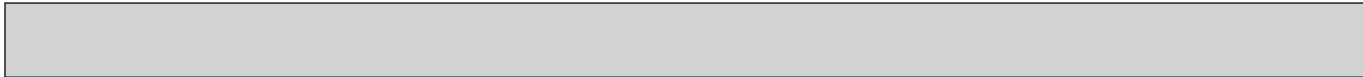

Service Ref.			PUHZ-SW75VAA-SC.UK	PUHZ-SW75YAA-SC.UK	
OUTDOOR UNIT	Power source (Phase, cycle, voltage)		Single, 50Hz, 230V	3-Phase 50 Hz, 400 V	
	Max. current	A	22.0	11.5	
	External finish		Munsell: N8.75 Munsell N2.75 (FRONT PANEL)		
	Refrigerant control		Linear Expansion Valve		
	Compressor		Hermetic		
		Model		SNB220FEGMC-L1	SNB220FEAMC-L1
		Motor output	kW	1.5	
		Starter type		Inverter	
		Protection devices		HP switch, Comp. surface thermo Discharge thermo, Over current detection	
	Crankcase heater	W	—		
	Heat exchanger		Plate fin coil		
	Fan	Fan (drive) × No.		Propeller fan x 1	
		Fan motor output	kW	0.074	
		Air flow	m³/min (CFM)	44(1,550)	
	Defrost method		Reverse cycle		
	Sound power level	Heating	dB	58	58
	Dimensions	W	mm (inch)	1020 (40-3/16)	
		D	mm (inch)	480 (18-7/8)	
		H	mm (inch)	1050 (41-5/16)	
	Weight		kg (lb)	92 (203)	104 (229)
Refrigerant		R410A			
	Charge	kg (lb)	2.9(6.29)		
	Oil (Model)	L	0.60(FV50S)		
Pipe size OD	Liquid	mm (inch)	9.52(3/8)		
	Gas	mm (inch)	15.88(5/8)		
Connection method	Indoor side		Flared		
	Outdoor side		Flared		
Between the indoor & outdoor	Height difference		Maximum 30 m		
	Piping length		2 to 40 m		

4-1. REFILLING REFRIGERANT CHARGE (R410A: kg)

Service Ref.	Piping length (one way)							Initial charged
	10 m	20 m	30 m	40 m	50 m	60 m	75 m	
PUHZ-SHW80VAA(-BS).UK PUHZ-SHW112VAA(-BS).UK PUHZ-SHW80YAA(-BS).UK PUHZ-SHW112YAA(-BS).UK	4.6	4.6	4.6	5.2	5.6	5.8	6.0	4.6
PUHZ-SW75VAA(-BS).UK PUHZ-SW75YAA(-BS).UK	3.0	3.6	4.2	4.8	—	—	—	3.0
PUHZ-SW75VAA-SC.UK PUHZ-SW75YAA-SC.UK	2.9	3.5	4.1	4.7	—	—	—	2.9
PUHZ-SW100VAA(-BS).UK PUHZ-SW100YAA(-BS).UK	4.2	4.4	4.6	5.2	5.6	5.8	6.0	4.2

Additional charge is required for pipes longer than 30 m (SHW80/SHW112) and 10 m (SW75/SW100).

4-2. COMPRESSOR TECHNICAL DATA

(at 20°C)

Service Ref.	PUHZ-SHW80VAA(-BS).UK PUHZ-SHW112VAA(-BS).UK	PUHZ-SHW80YAA(-BS).UK PUHZ-SHW112YAA(-BS).UK	PUHZ-SW75VAA(-BS).UK PUHZ-SW75VAA-SC.UK	PUHZ-SW75YAA(-BS).UK PUHZ-SW75YAA-SC.UK
Compressor model	DNK28FBAMT	DNK28FBBMT	SNB220FEGMC-L1	SNB220FEAMC-L1
Winding Resistance (Ω)	U-V	0.74	0.94	0.95
	U-W	0.74	0.94	0.95
	W-V	0.74	0.94	0.95

Service Ref.	PUHZ-SW100VAA(-BS).UK	PUHZ-SW100YAA(-BS).UK
Compressor model	DNB28FBAMT	DNB28FBBMT
Winding Resistance (Ω)	U-V	0.74
	U-W	0.74
	W-V	0.74

4-3. NOISE CRITERION CURVES

PUHZ-SHW80VAA(-BS).UK
 PUHZ-SHW80YAA(-BS).UK

MODE	SPL(dB)	LINE
COOLING	48	○—○
HEATING	45	●—●

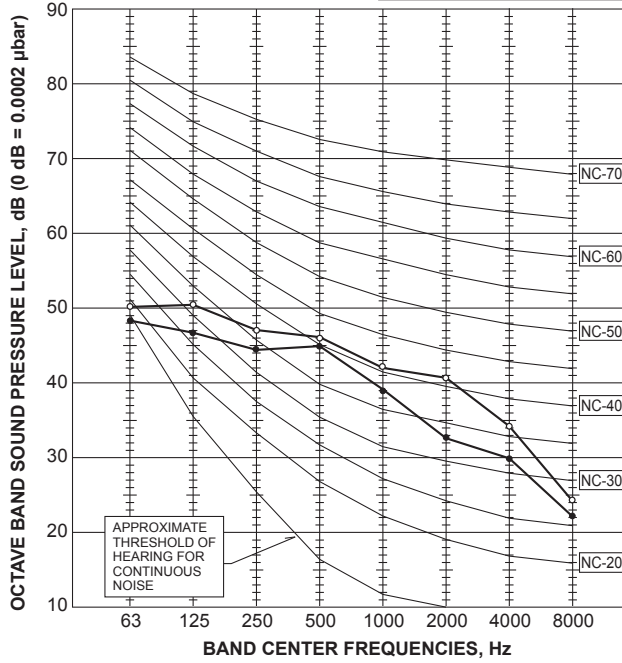

PUHZ-SHW112VAA(-BS).UK
 PUHZ-SHW112YAA(-BS).UK
 PUHZ-SW100VAA(-BS).UK
 PUHZ-SW100YAA(-BS).UK

MODE	SPL(dB)	LINE
COOLING	49	○—○
HEATING	47	●—●

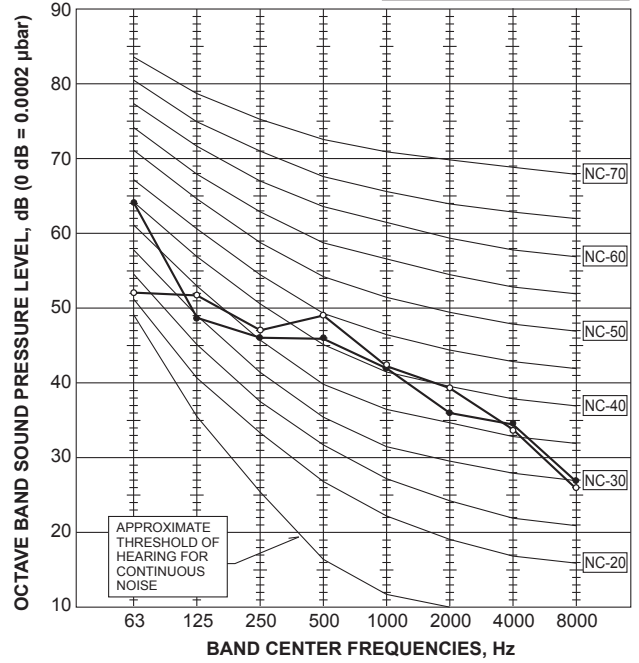

PUHZ-SW75VAA(-BS).UK
 PUHZ-SW75YAA(-BS).UK

MODE	SPL(dB)	LINE
COOLING	45	○—○
HEATING	43	●—●

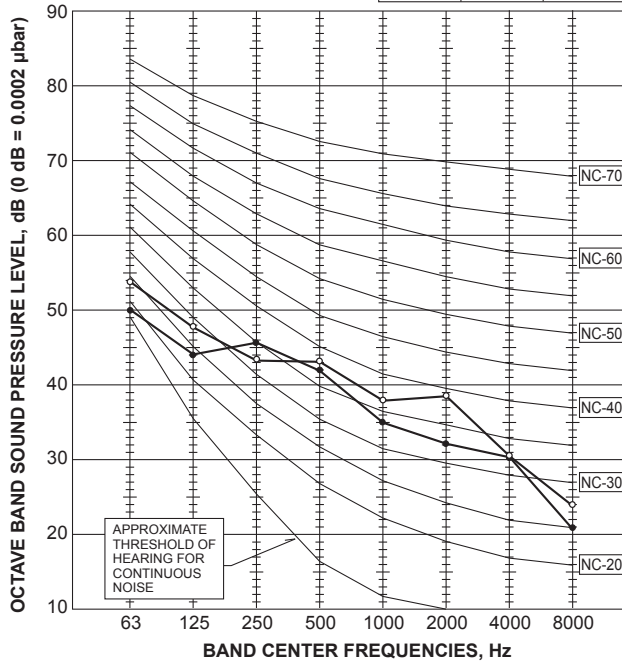

PUHZ-SW75VAA-SC.UK
 PUHZ-SW75YAA-SC.UK

MODE	SPL(dB)	LINE
COOLING	46	○—○
HEATING	43	●—●

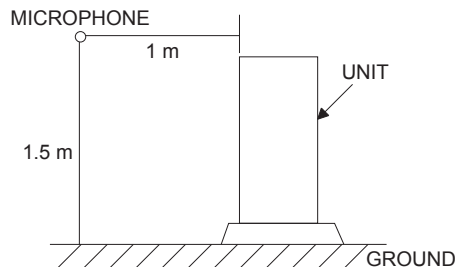
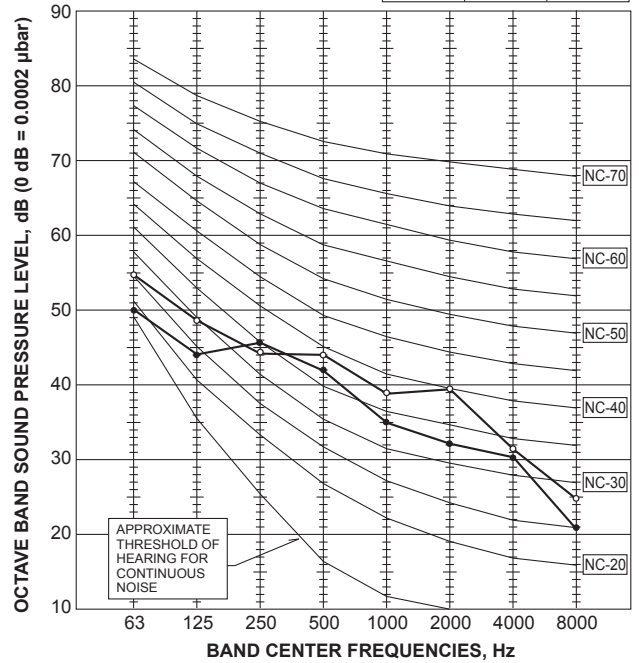

PUHZ-SHW80VAA.UK
 PUHZ-SHW80VAA-BS.UK
 PUHZ-SW75VAA.UK
 PUHZ-SW75VAA-BS.UK
 PUHZ-SW75VAA-SC.UK

PUHZ-SHW112VAA.UK
 PUHZ-SHW112VAA-BS.UK
 PUHZ-SW100VAA.UK
 PUHZ-SW100VAA-BS.UK
 PUHZ-SW75YAA-SC.UK

PUHZ-SHW80YAA.UK
 PUHZ-SHW80YAA-BS.UK
 PUHZ-SW75YAA.UK
 PUHZ-SW75YAA-BS.UK

PUHZ-SHW112YAA.UK
 PUHZ-SHW112YAA-BS.UK
 PUHZ-SW100YAA.UK
 PUHZ-SW100YAA-BS.UK

Unit: mm

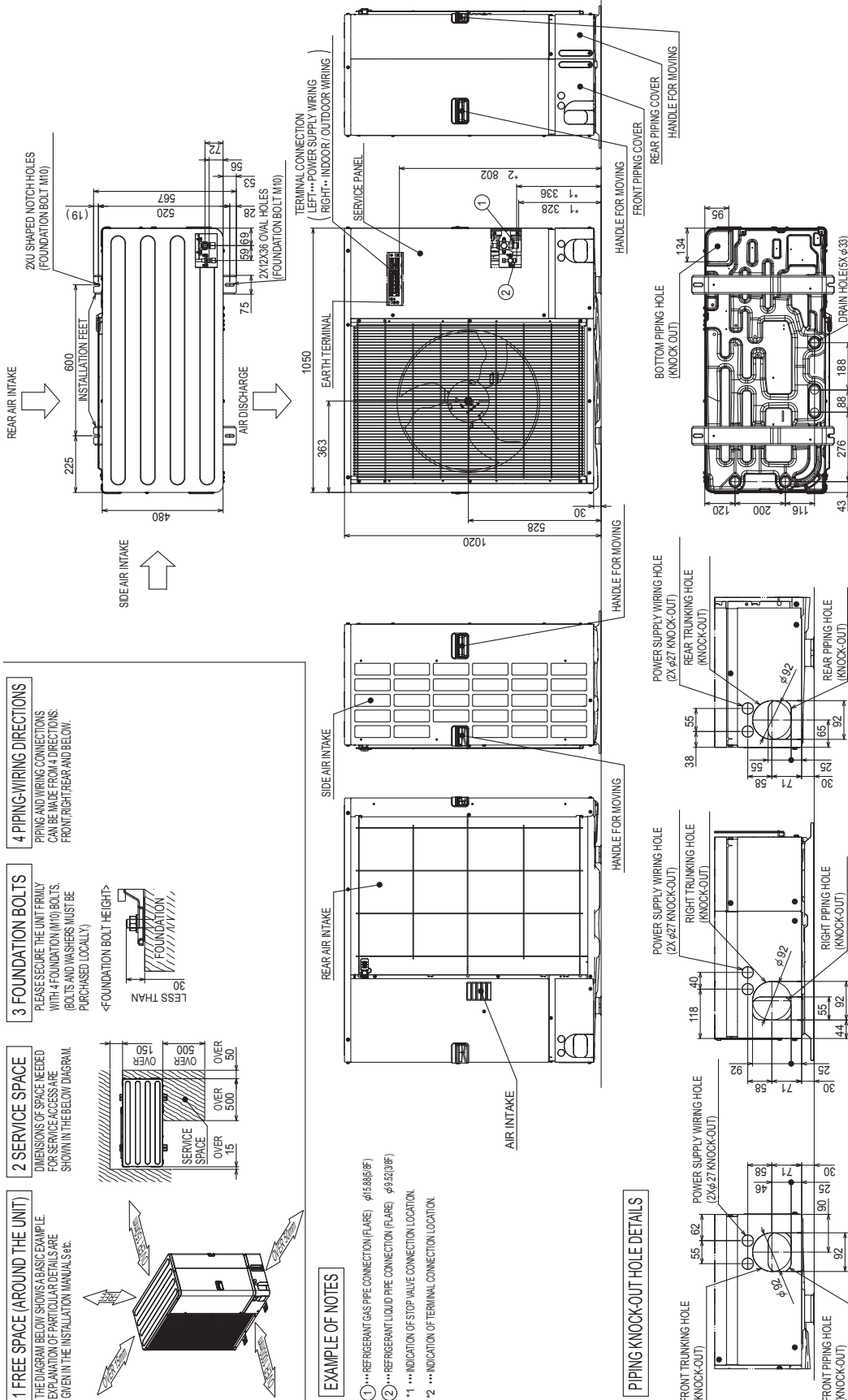

PUHZ-SHW80VAA.UK
PUHZ-SHW80VAA-BS.UK

PUHZ-SHW112VAA.UK
PUHZ-SHW112VAA-BS.UK

SYMBOL	NAME	SYMBOL	NAME
TB1	Terminal Block <Power Supply, Indoor/Outdoor>	PB	Power Circuit Board
MC	Motor for Compressor	CB	Controller Circuit Board
MF1	Fan Motor	SW1	Switch <Manual Defrost, Defect History Record Reset, Refrigerant Address>
21S4	Solenoid Valve (4-Way Valve)	SW4	Switch <Function Switch>
63H	High Pressure Switch	SW5	Switch <Function Switch>
63L	Low Pressure Switch	SW6	Switch <Function Switch, Model Select>
63HS	High Pressure Sensor	SW7	Switch <Function Switch>
TH3	Thermistor <Liquid>	SW8	Switch <Function Switch>
TH4	Thermistor <Discharge>	SW9	Switch <Function Switch>
TH6	Thermistor <2-Phase Pipe>	SWP	Switch <Pump Down>
TH7	Thermistor <Ambient>	CNDM	Connector <Connection for Option>
TH8	Thermistor <Heat Sink>	SV1/CH	Connector <Connection for Option>
TH32	Thermistor <Suction>	SV3/SS	Connector <Connection for Option>
TH33	Thermistor <Comp. Surface>	CNM	Connector <Connection for Option>
LEV-A, LEV-B, LEV-C	Linear Expansion Valve	F1, F2, F3, F4	Fuse <T6.3AL250V>
DCL1, DCL2, DCL3	Reactor		
CY1, CY2	Capacitor		

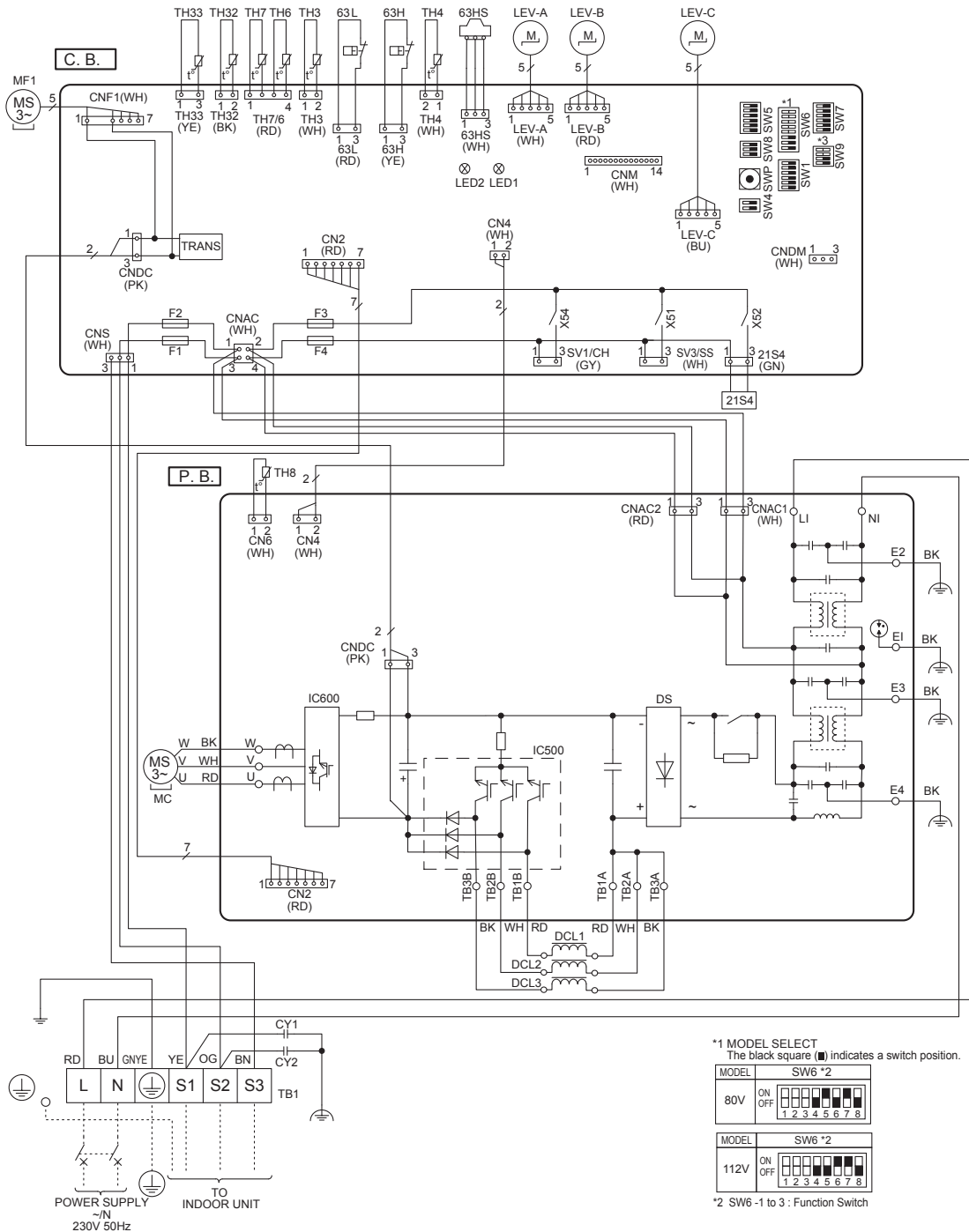

*3 Ambient temp. of ZUBADAN Flash Injection becomes effective.
The black square (■) indicates a switch position.

Ambient temp.	SW9-3, 9-4 *4	Ambient temp.	SW9-3, 9-4 *4	Ambient temp.	SW9-3, 9-4 *4	Ambient temp.	SW9-3, 9-4 *4
3°C or less (Default setting)	ON OFF ■■■ 1 2 3 4	0°C or less	ON OFF ■■■ 1 2 3 4	-3°C or less	ON OFF ■■■ 1 2 3 4	-6°C or less	ON OFF ■■■ 1 2 3 4

*4 SW9-1 to 2 : Function Switch

*1 MODEL SELECT
The black square (■) indicates a switch position.

MODEL	SW6 *2
80V	ON OFF ■■■■ 1 2 3 4 5 6 7 8

MODEL	SW6 *2
112V	ON OFF ■■■■ 1 2 3 4 5 6 7 8

*2 SW6 -1 to 3 : Function Switch

PUHZ-SHW80YAA.UK
PUHZ-SHW80YAA-BS.UK

PUHZ-SHW112YAA.UK
PUHZ-SHW112YAA-BS.UK

SYMBOL	NAME	SYMBOL	NAME	SYMBOL	NAME
TB1	Terminal Block <Power Supply>	TH33	Thermistor <Comp. Surface>	SW5	Switch <Function Switch>
TB2	Terminal Block <Indoor/Outdoor>	LEV-A	Linear Expansion Valve	SW6	Switch <Function Switch, Model Select>
MC	Motor for Compressor	ACL1, ACL2	ACL3, ACL4	SW7	Switch <Function Switch>
MF1	Fan Motor	CY1, CY2	Capacitor	SW8	Switch <Function Switch>
21S4	Solenoid Valve (4-Way Valve)	CK	Capacitor	SW9	Switch <Function Switch>
63H	High Pressure Switch	RS	Rush Current Protect Resistor	SWP	Switch <Pump Down>
63L	Low Pressure Switch	P. B.	Power Circuit Board	CNDM	Connector <Connection for Option>
63HS	High Pressure Sensor	N. F.	Noise Filter Circuit Board	SV1/CH	Connector <Connection for Option>
TH3	Thermistor <Liquid>	CONV. B.	Converter Circuit Board	SV3/SS	Connector <Connection for Option>
TH4	Thermistor <Discharge>	C. B.	Controller Circuit Board	CNM	Connector <Connection for Option>
TH6	Thermistor <2-Phase Pipe>	SW1	Switch <Manual Defrost, Defrost History Record Reset, Refrigerant Address>	F1, F2, F3, F4	Fuse <T6.3AL250V>
TH7	Thermistor <Ambient>	SW4	Switch <Function Switch>		
TH8	Thermistor <Heat Sink>				
TH32	Thermistor <Suction>				

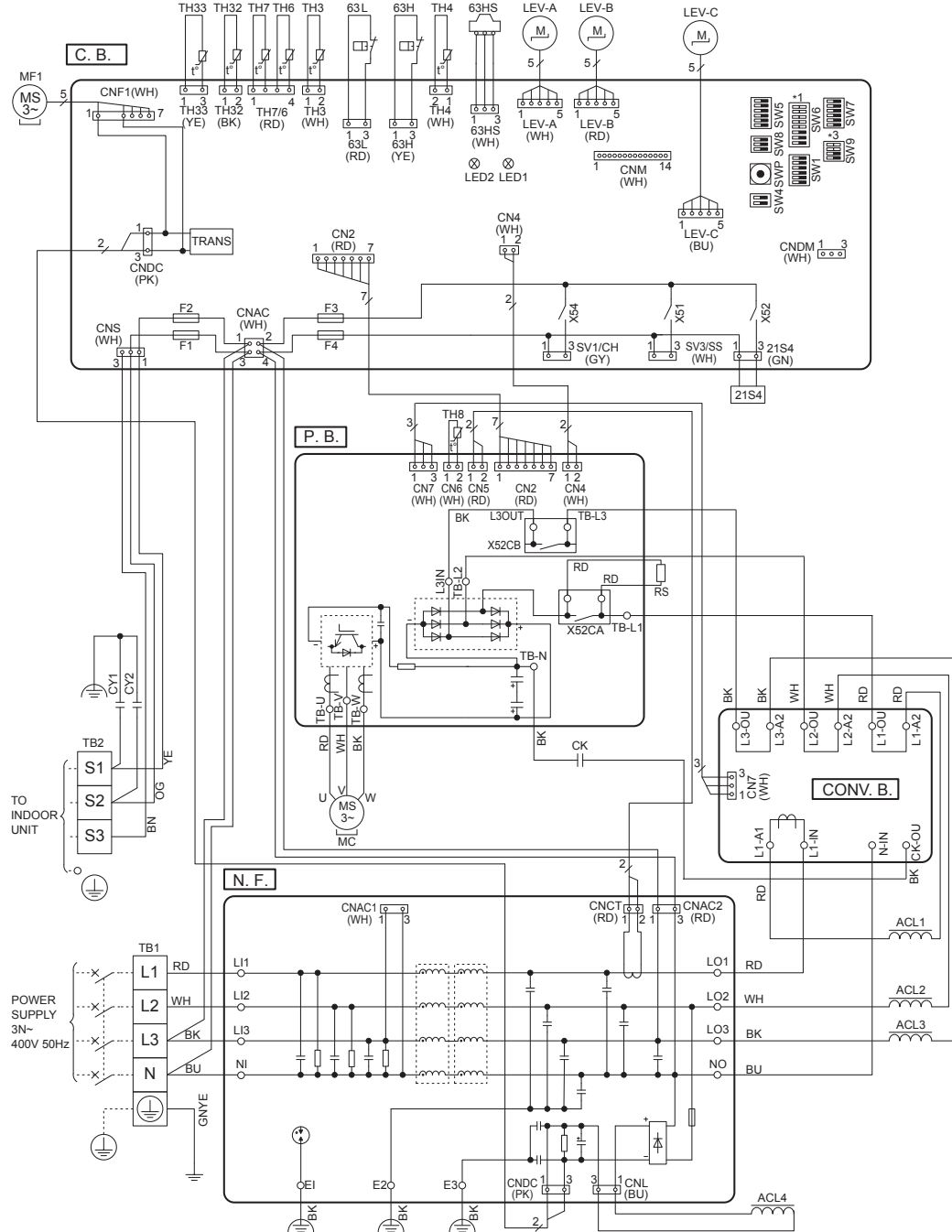

*2 SW6 -1 to 3 : Function Switch
 *3 Ambient temp. of ZUBADAN Flash Injection becomes effective.
 The black square (■) indicates a switch position.
 Ambient temp. 3°C or less (Default setting) SW9-3, 9-4 *4
 Ambient temp. 0°C or less SW9-3, 9-4 *4
 Ambient temp. -3°C or less SW9-3, 9-4 *4
 Ambient temp. -6°C or less SW9-3, 9-4 *4
 *4 SW9-1 to 2 : Function Switch

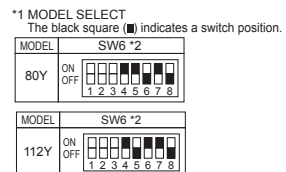

PUHZ-SW75VAA.UK
 PUHZ-SW75VAA-BS.UK
 PUHZ-SW75VAA-SC.UK

PUHZ-SW100VAA.UK
 PUHZ-SW100VAA-BS.UK

SYMBOL	NAME	SYMBOL	NAME
TB1	Terminal Block <Power Supply, Indoor/Outdoor>	C.B.	Controller Circuit Board
MC	Motor for Compressor	SW1	Switch <Manual Defrost, Defect History Record Reset, Refrigerant Address>
MF1	Fan Motor	SW4	Switch <Function Switch>
21S4	Solenoid Valve (4-Way Valve)	SW5	Switch <Function Switch>
63H	High Pressure Switch	SW6	Switch <Function Switch, Model Select>
63L	Low Pressure Switch	SW7	Switch <Function Switch>
63HS	High Pressure Sensor	SW8	Switch <Function Switch>
TH3	Thermistor <Liquid>	SW9	Switch <Function Switch>
TH4	Thermistor <Discharge>	SWP	Switch <Pump Down>
TH6	Thermistor <2-Phase Pipe>	CNDM	Connector <Connection for Option>
TH7	Thermistor <Ambient>	SV1/CH	Connector <Connection for Option>
TH8	Thermistor <Heat Sink>	SV3/SS	Connector <Connection for Option>
TH33	Thermistor <Comp. Surface>	CNM	Connector <Connection for Option>
LEV-A, LEV-B	Linear Expansion Valve	F1, F2, F3, F4	Fuse <T6.3AL250V>
DCL1, DCL2, DCL3	Reactor		
CY1, CY2	Capacitor		
P.B.	Power Circuit Board		

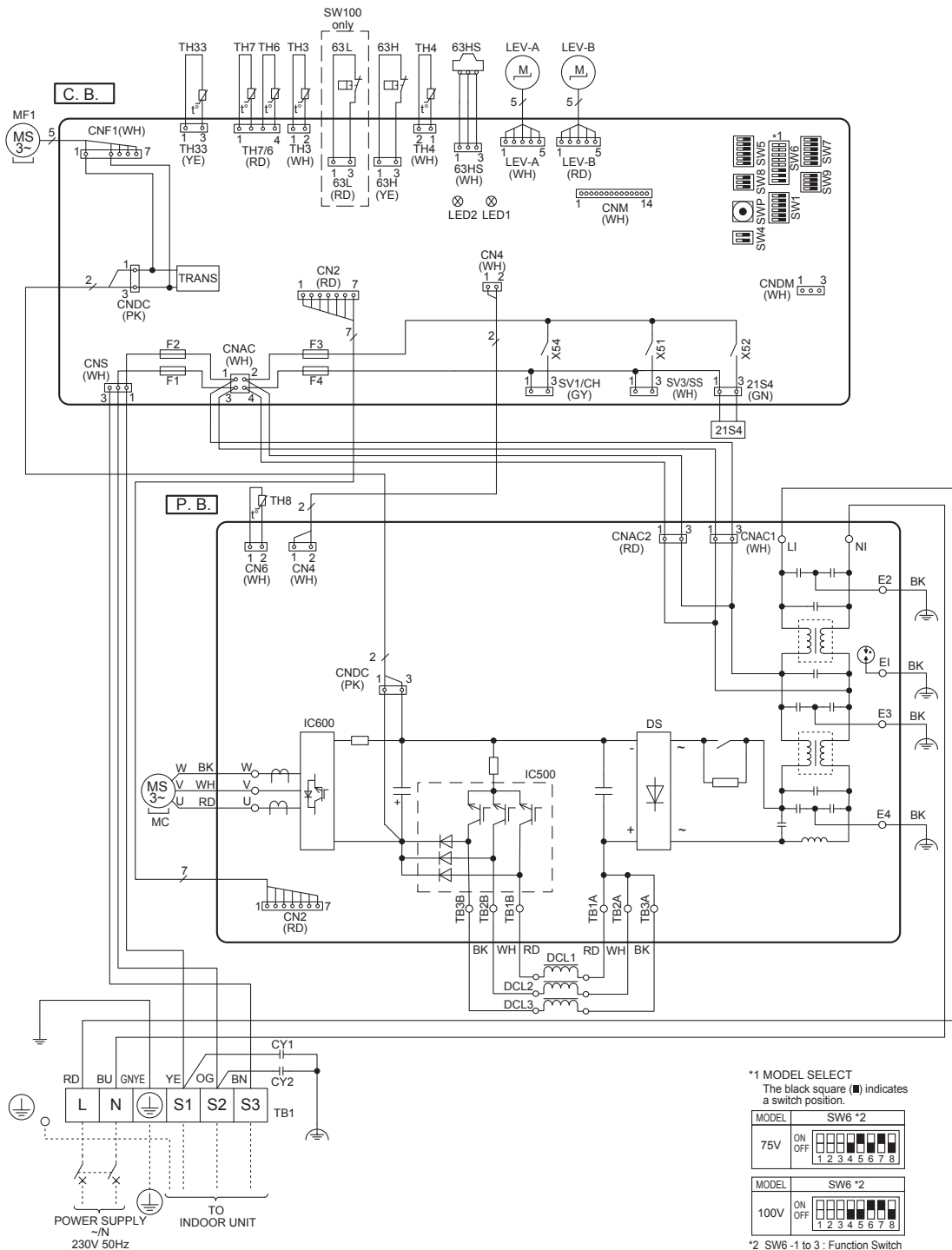

PUHZ-SW75YAA.UK
PUHZ-SW75YAA-BS.UK
PUHZ-SW75YAA-SC.UK

PUHZ-SW100YAA.UK
PUHZ-SW100YAA-BS.UK

SYMBOL	NAME	SYMBOL	NAME	SYMBOL	NAME
TB1	Terminal Block <Power Supply>	TH33	Thermistor <Comp. Surface>	SW4	Switch <Function Switch>
TB2	Terminal Block <Indoor/Outdoor>	LEV-A, LEV-B	Linear Expansion Valve	SW5	Switch <Function Switch>
MC	Motor for Compressor	ACL1, ACL2	Reactor	SW6	Switch <Function Switch, Model Select>
MF1	Fan Motor	ACL3, ACL4		SW7	Switch <Function Switch>
21S4	Solenoid Valve (4-Way Valve)	CY1, CY2	Capacitor	SW8	Switch <Function Switch>
63H	High Pressure Switch	CK	Capacitor	SW9	Switch <Function Switch>
63L	Low Pressure Switch	RS	Rush Current Protect Resistor	SWP	Switch <Pump Down>
63HS	High Pressure Sensor	P. B.	Power Circuit Board	CNDM	Connector <Connection for Option>
TH3	Thermistor <Liquid>	N. F.	Noise Filter Circuit Board	SV1/CH	Connector <Connection for Option>
TH4	Thermistor <Discharge>	CONV. B.	Converter Circuit Board	SV3/SS	Connector <Connection for Option>
TH6	Thermistor <2-Phase Pipe>	C. B.	Controller Circuit Board	CNM	Connector <Connection for Option>
TH7	Thermistor <Ambient>	SW1	Switch <Manual Defrost, Defect History Record Reset, Refrigerant Address>	F1, F2, F3, F4	Fuse <T6.3AL250V>
TH8	Thermistor <Heat Sink>				

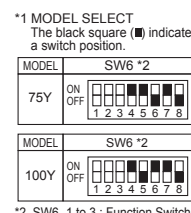
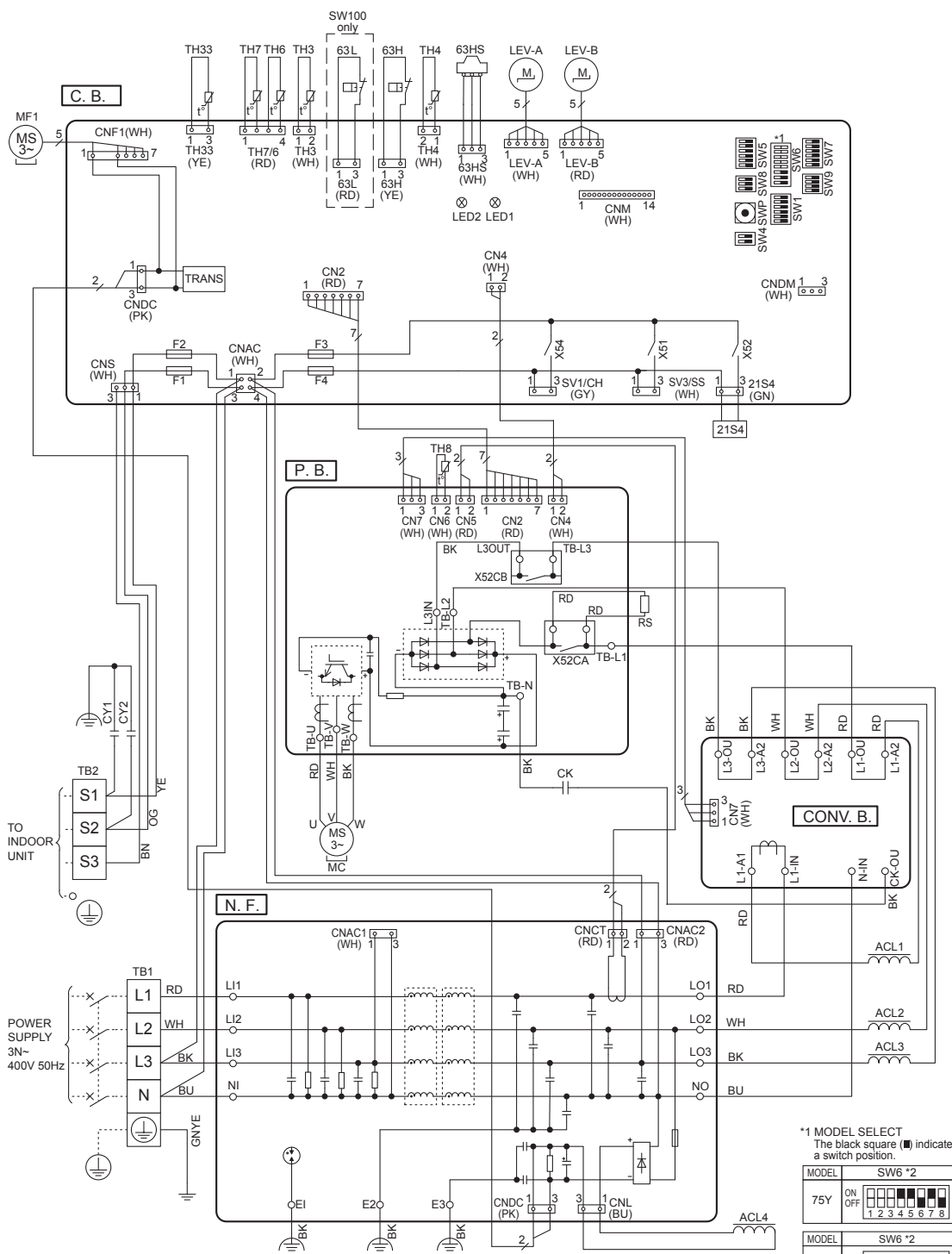

FIELD ELECTRICAL WIRING (power wiring specifications)

Outdoor unit model		SW75V, SHW80V	SW100V, SHW112V	SW75, 100Y SHW80, 112Y
Outdoor unit power supply		~N (single), 50 Hz, 230 V	~N (single), 50 Hz, 230 V	3N~ (3 ph 4-wires), 50 Hz, 400 V
Outdoor unit input capacity Main switch (Breaker) *1		25A	32A	16A
Wiring Wire No. x size (mm ²)	Outdoor unit power supply	3 × Min. 2.5	3 × Min. 4	5 × Min. 1.5
	Indoor unit-Outdoor unit	*2 3 × 1.5 (polar)	3 × 1.5 (polar)	3 × 1.5 (polar)
	Indoor unit-Outdoor unit earth	*2 1 × Min. 1.5	1 × Min. 1.5	1 × Min. 1.5
	Remote controller-Indoor unit	*3 2 × 0.3 (Non-polar)	2 × 0.3 (Non-polar)	2 × 0.3 (Non-polar)
Circuit rating	"Outdoor unit L-N (single) Outdoor unit L1-N, L2-N, L3-N (3 phase)"	*4 230 V AC	230 V AC	230 V AC
	Indoor unit-Outdoor unit S1-S2	*4 230 V AC	230 V AC	230 V AC
	Indoor unit-Outdoor unit S2-S3	*4 24 V DC	24 V DC	24 V DC
	Remote controller-Indoor unit	*4 12 V DC	12 V DC	12 V DC

*1. A breaker with at least 3.0 mm contact separation in each pole shall be provided. Use earth leakage breaker (NV).

Make sure that the current leakage breaker is one compatible with higher harmonics.

Always use a current leakage breaker that is compatible with higher harmonics as this unit is equipped with an inverter.

The use of an inadequate breaker can cause the incorrect operation of inverter.

*2. Maximum 45 m

If 2.5 mm² is used, maximum 50 m.

If 2.5 mm² is used and S3 is separated, maximum 80 m.

*3. The 10 m wire is attached in the remote controller accessory.

*4. The figures are NOT always against the ground.

S3 terminal has 24 V DC against S2 terminal. However between S3 and S1, these terminals are NOT electrically insulated by the transformer or other device.

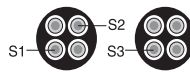

Notes: 1. Wiring size must comply with the applicable local and national codes.

2. Power supply cables and the cables between Interface unit/Flow temp. controller and outdoor unit shall not be lighter than polychloroprene sheathed flexible cables. (Design 60245 IEC 57)

3. Be sure to connect the cables between Interface unit/Flow temp. controller and outdoor unit directly to the units (no intermediate connections are allowed).

Intermediate connections may result in communication errors. If water enters at the intermediate connection point, it may cause insufficient insulation to ground or a poor electrical contact.

(If an intermediate connection is necessary, be sure to take measures to prevent water from entering the cables.)

4. Install an earth longer than other cables.

5. Do not construct a system with a power supply that is turned ON and OFF frequently.

6. Use self-extinguishing distribution cable for power supply wiring.

7. Properly route wiring so as not to contact the sheet metal edge or screw tip.

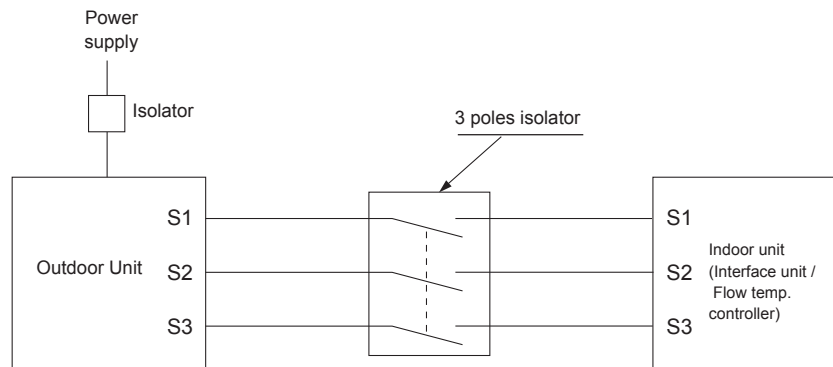

Warning:

- In case of A-control wiring, there is high voltage potential on the S3 terminal caused by electrical circuit design that has no electrical insulation between power line and communication signal line. Therefore, please turn off the main power supply when servicing. And do not touch the S1, S2, S3 terminals when the power is energized. If isolator should be used between indoor unit and outdoor unit, please use 3-pole type.

Never splice the power cable or the indoor-outdoor connection cable, otherwise it may result in smoke emission, a fire or communication failure.

REFRIGERANT SYSTEM DIAGRAM

PUHZ-SHW80VAA.UK
 PUHZ-SHW80VAA-BS.UK
 PUHZ-SHW80YAA.UK
 PUHZ-SHW80YAA-BS.UK

PUHZ-SHW112VAA.UK
 PUHZ-SHW112VAA-BS.UK
 PUHZ-SHW112YAA.UK
 PUHZ-SHW112YAA-BS.UK

unit: mm (in)

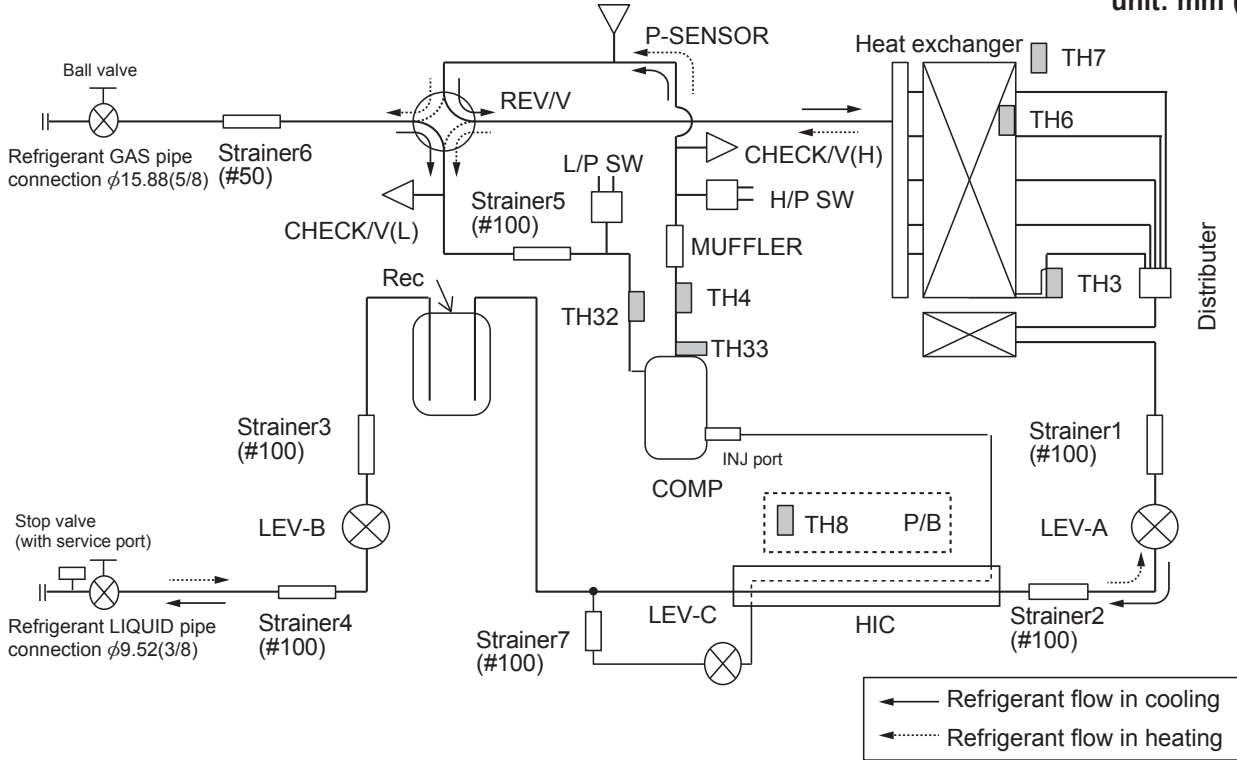

PUHZ-SW100VAA.UK
 PUHZ-SW100VAA-BS.UK

PUHZ-SW100YAA.UK
 PUHZ-SW100YAA-BS.UK

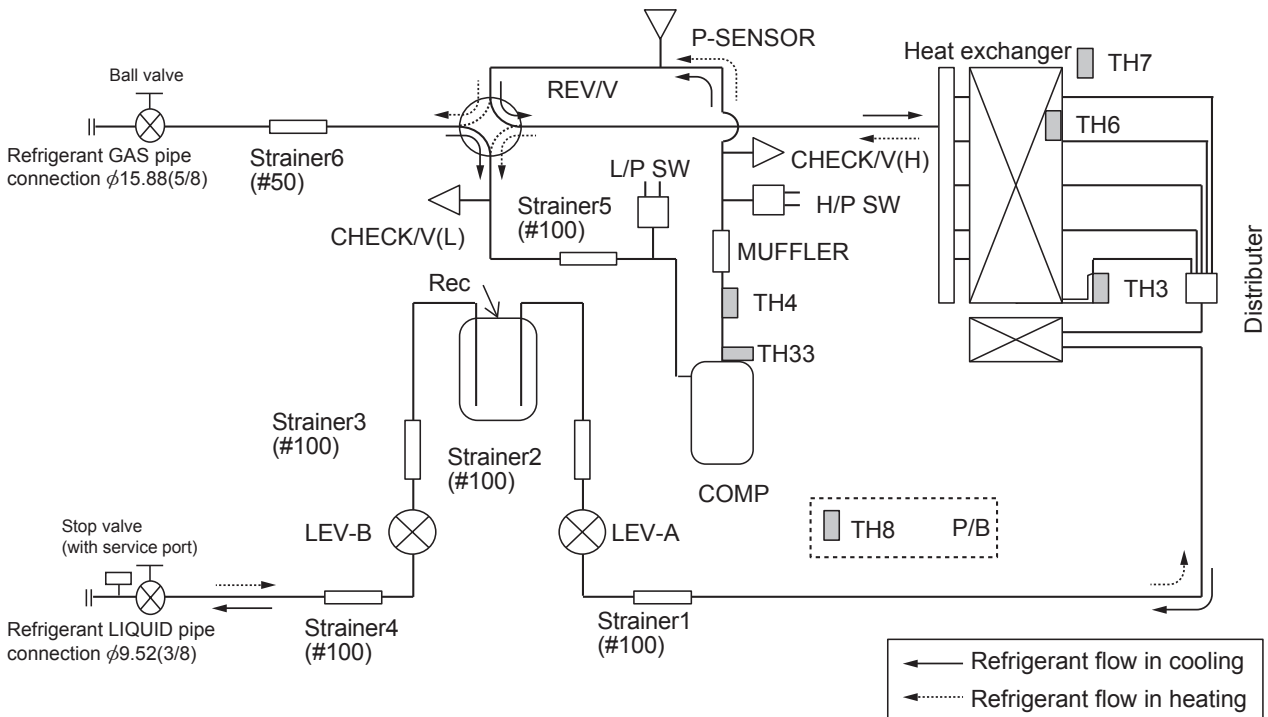

PUHZ-SW75VAA.UK
 PUHZ-SW75VAA-BS.UK
 PUHZ-SW75VAA-SC.UK

PUHZ-SW75YAA.UK
 PUHZ-SW75YAA-BS.UK
 PUHZ-SW75YAA-SC.UK

unit: mm (in)

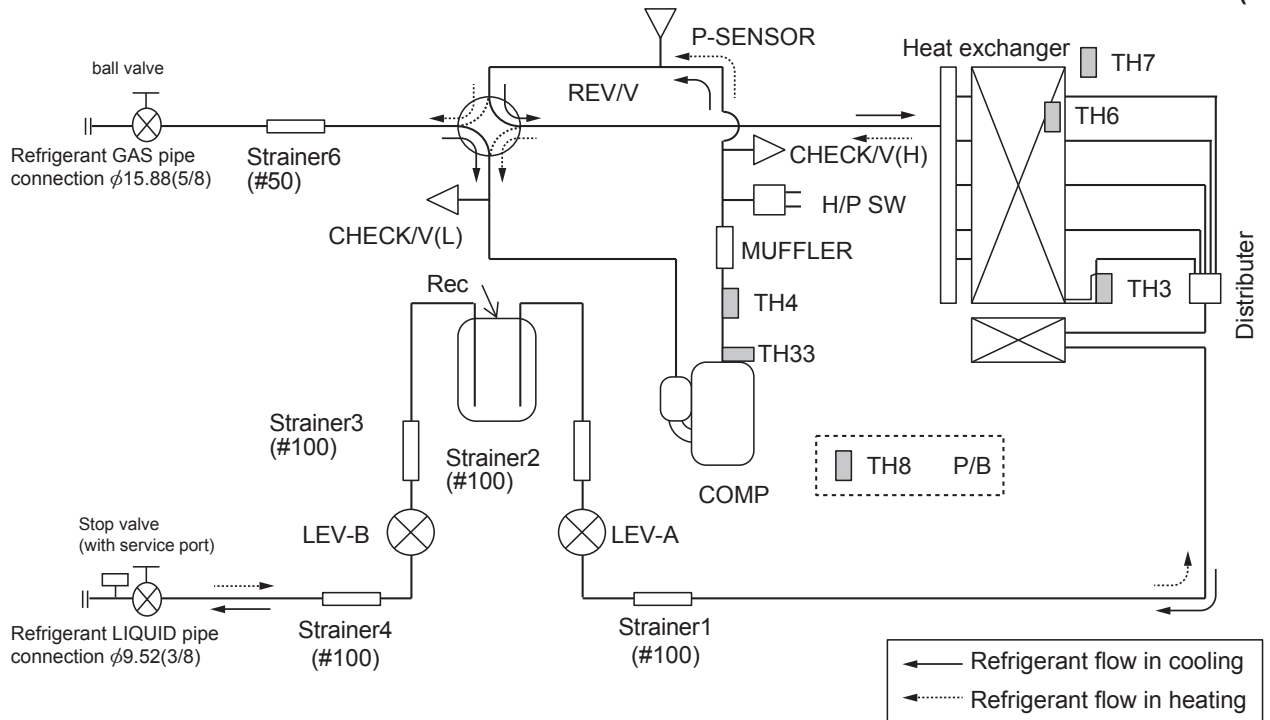

Symbol	Parts name	Detail	
COMP	Compressor	DC inverter scroll compressor (Mitsubishi Electric Corporation)	
H/P SW	High pressure switch (63H)	For protection (OFF: 4.15MPa)	
L/P SW	Low pressure switch (63L)	For protection (OFF: -0.03MPa)	
REV/V	Reversing (4-way) valve (21S4)	Change the refrigerant circuit (Heating / Cooling) and for Defrosting	
CHECK/V	Charge plug	High pressure/Low pressure/For production test use	
P-SENSOR	Pressure sensor (63HS)	For calculation of the condensing temperature from high pressure	
LEV-A	Linear expansion valve -A	Heating:Secondary LEV Cooling:Primary LEV	
LEV-B	Linear expansion valve -B	Heating:Primary LEV Cooling:Secondary LEV	
LEV-C	Linear expansion valve -C	For HIC (heating only)	
TH32 (PUHZ-SHW only)	Suction temperature thermistor	For LEV control	
TH3	Liquid temperature thermistor	Heating:Evaporating temperature Cooling:Sub cool liquid temperature	
TH4	Discharge temperature thermistor	For LEV control and for compressor protection	
TH6	2-phase pipe temperature thermistor	Outdoor 2-phase pipe temperature	
TH7	Ambient temperature thermistor	For fan control and for compressor frequency control	
TH33	Comp. surface temperature thermistor	For protection	
Rec	Receiver	For accumulation of refrigerant	
HIC	Heat interchange circuit	For high heating capacity	
Plate HEX	Plate Heat Exchanger	SHW112/SHW80/SW100: MWA2-38PA SW75: MWA1-44DM	
TH1	Outlet water temperature thermistor	For flow temp. controller	<Reference> System example
TH2	Liquid pipe temperature thermistor	For flow temp. controller	

8-1. REFRIGERANT COLLECTING (PUMP DOWN)

When relocating or disposing of the indoor/outdoor unit, pump down the system following the procedure below so that no refrigerant is released into the atmosphere.

- ① Turn off the power supply (circuit breaker).
- ② Connect the low-pressure valve on the gauge manifold to the charge plug (low-pressure side) on the outdoor unit.
- ③ Close the liquid stop valve completely.
- ④ Supply power (circuit breaker).
 - When power is supplied, make sure that “CENTRALLY CONTROLLED” is not displayed on the remote controller. If “CENTRALLY CONTROLLED” is displayed, the refrigerant collecting (pump down) cannot be completed normally.
 - Startup of the indoor-outdoor communication takes about 3 minutes after the power (circuit breaker) is turned on. Start the pump-down operation 3 to 4 minutes after the power (circuit breaker) is turned on.
- ⑤ Perform the refrigerant collecting operation (cooling test run).
 - Push the pump-down SWP switch (push-button type) on the control board of the outdoor unit. The compressor and ventilators (indoor and outdoor units) start operating (refrigerant collecting operation begins). (LED1 and LED2 on the control board of the outdoor unit are lit.)
 - Only push the pump-down SWP switch if the unit is stopped. However, even if the unit is stopped and the pump-down SWP switch is pushed less than 3 minutes after the compressor stops, the refrigerant collecting operation cannot be performed. Wait until the compressor has been stopped for 3 minutes and then push the pump-down SWP switch again.
- ⑥ Fully close the ball valve on the gas pipe side of the outdoor unit when the pressure gauge on the gauge manifold shows 0.05 to 0 MPa [Gauge] (approx. 0.5 to 0 kgf/cm²) and quickly stop the air conditioner.
 - Because the unit automatically stops in about 3 minutes when the refrigerant collecting operation is completed (LED1 off, LED2 lit), be sure to quickly close the gas ball valve. However, if LED1 is lit, LED2 is off, and the unit is stopped, open the liquid stop valve completely, close the valve completely after 3 minutes or more have passed, and then repeat step ⑤. (Open the gas ball valve completely.)
 - If the refrigerant collecting operation has been completed normally (LED1 off, LED2 lit), the unit will remain stopped until the power supply is turned off.
 - Note that when the extension piping is very long with a large refrigerant amount, it may not be possible to perform a pump-down operation. In this case, use refrigerant recovery equipment to collect all of the refrigerant in the system.
- ⑦ Turn off the power supply (circuit breaker), remove the gauge manifold, and then disconnect the refrigerant pipes.

⚠ Warning:

When pumping down the refrigerant, stop the compressor before disconnecting the refrigerant pipes.

- **If the refrigerant pipes are disconnected while the compressor is operating and the stop valve (ball valve) is open, the pressure in the refrigeration cycle could become extremely high if air is drawn in, causing the pipes to burst, personal injury, etc.**

9-1. TROUBLESHOOTING

<Check code displayed by self-diagnosis and actions to be taken for service (summary)>

Present and past check codes are logged, and they can be displayed on the control board of outdoor unit. Actions to be taken for service, which depends on whether or not the trouble is reoccurring in the field, are summarized in the table below. Check the contents below before investigating details.

Unit conditions at service	Check code	Actions to be taken for service (summary)
The trouble is reoccurring.	Displayed	Judge what is wrong and take a corrective action according to "9-2. SELF-DIAGNOSIS ACTION TABLE".
	Not displayed	Conduct troubleshooting and ascertain the cause of the trouble according to "9-3. TROUBLESHOOTING OF PROBLEMS".
The trouble is not reoccurring.	Logged	<ul style="list-style-type: none"> ① Consider the temporary defects such as the work of protection devices in the refrigerant circuit including compressor, poor connection of wiring, noise, etc. Re-check the symptom, and check the installation environment, refrigerant amount, weather when the trouble occurred, matters related to wiring, etc. ② Reset check code logs and restart the unit after finishing service. ③ There is no abnormality in electrical component, controller board, remote controller, etc.
	Not logged	<ul style="list-style-type: none"> ① Re-check the abnormal symptom. ② Conduct troubleshooting and ascertain the cause of the trouble according to "9-3. TROUBLESHOOTING OF PROBLEMS". ③ Continue to operate unit for the time being if the cause is not ascertained. ④ There is no abnormality concerning of parts such as electrical component, controller board, remote controller, etc.

9-2. SELF-DIAGNOSIS ACTION TABLE

<Abnormalities detected when the power is turned on>

Note: Refer to indoor unit section for code P, code E, and Code L.

Check code	Abnormal point and detection method	Cause	Judgment and action
None	—	<p>① No voltage is supplied to terminal block (TB1) of outdoor unit. a) Power supply breaker is turned off. b) Contact failure or disconnection of power supply terminal c) Open phase (L or N phase)</p> <p>② Electric power is not charged to power supply terminal of outdoor power circuit board. a) Contact failure of power supply terminal b) Open phase on the outdoor power circuit board</p> <p>③ Electric power is not supplied to outdoor controller circuit board. a) Disconnection of connector (CNDC)</p> <p>④ Disconnection of reactor (DCL or ACL)</p> <p>⑤ Disconnection of outdoor noise filter circuit board or parts failure in outdoor noise filter circuit board</p> <p>⑥ Defective outdoor power circuit board</p> <p>⑦ Defective outdoor controller circuit board</p>	<p>① Check following items. a) Power supply breaker b) Connection of power supply terminal block (TB1) c) Connection of power supply terminal block (TB1)</p> <p>② Check following items. a) Connection of power supply terminal block (TB1) b) Connection of terminal on outdoor power circuit board Check connection of the connector LI or NI. Refer to "9-6.TEST POINT DIAGRAM".</p> <p>③ Check connection of the connector (CNDC) on the outdoor controller circuit board. Check connection of the connector, CNDC on the outdoor power circuit board(V)/the noise filter(Y). Refer to "9-6.TEST POINT DIAGRAM".</p> <p>④ Check connection of reactor. (DCL or ACL) Refer to "9-6.TEST POINT DIAGRAM".</p> <p>⑤ a) Check connection of outdoor noise filter circuit board. b) Replace outdoor noise filter circuit board. Refer to "9-6.TEST POINT DIAGRAM".</p> <p>⑥ Replace outdoor power circuit board.</p> <p>⑦ Replace controller board (When items above are checked but the units cannot be repaired).</p>
F3 (5202)	<p>63L connector open (SW100/SHW80/SHW112 only) Abnormal if 63L connector circuit is open for 3 minutes continuously after power supply.</p> <p>63L: Low pressure switch</p>	<p>① Disconnection or contact failure of 63L connector on outdoor controller circuit board</p> <p>② Disconnection or contact failure of 63L</p> <p>③ 63L is working due to refrigerant leakage or defective parts.</p> <p>④ Defective outdoor controller circuit board</p>	<p>① Check connection of 63L connector on outdoor controller circuit board. Refer to "9-6.TEST POINT DIAGRAM".</p> <p>② Check the 63L side of connecting wire.</p> <p>③ Check refrigerant pressure. Charge additional refrigerant. Check continuity by tester. Replace the parts if the parts are defective.</p> <p>④ Replace outdoor controller circuit board.</p>
F5 (5201)	<p>63H connector open Abnormal if 63H connector circuit is open for 3 minutes continuously after power supply.</p> <p>63H: High pressure switch</p>	<p>① Disconnection or contact failure of 63H connector on outdoor controller circuit board</p> <p>② Disconnection or contact failure of 63H</p> <p>③ 63H is working due to defective parts.</p> <p>④ Defective outdoor controller circuit board</p>	<p>① Check connection of 63H connector on outdoor controller circuit board. Refer to "9-6.TEST POINT DIAGRAM".</p> <p>② Check the 63H side of connecting wire.</p> <p>③ Check continuity by tester. Replace the parts if the parts are defective.</p> <p>④ Replace outdoor controller circuit board.</p>

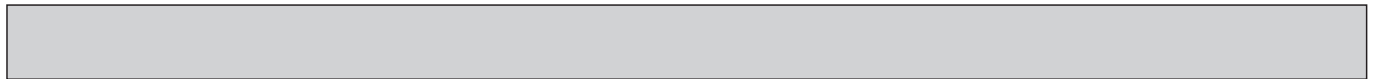

Check Code	Abnormal point and detection method	Cause	Judgment and action
F9 (4119)	<p>2 connector open (SW100/SHW80/SHW112 only) Abnormal if both 63H and 63L connector circuits are open for three minutes continuously after power supply.</p> <p>63H: High pressure switch 63L: Low pressure switch</p>	<p>① Disconnection or contact failure of connector (63H,63L) on outdoor controller circuit board</p> <p>② Disconnection or contact failure of 63H, 63L</p> <p>③ 63H and 63L are working due to defective parts.</p> <p>④ Defective outdoor controller board</p>	<p>① Check connection of connector (63H,63L) on outdoor controller circuit board. Refer to "9-6.TEST POINT DIAGRAM".</p> <p>② Check the 63H and 63L side of connecting wire.</p> <p>③ Check continuity by tester. Replace the parts if the parts are defective.</p> <p>④ Replace outdoor controller circuit board.</p>
EA (6844)	<p>Indoor/outdoor unit connector miswiring, excessive number of units (2 units or more)</p> <p>1. Outdoor controller circuit board can automatically check the number of connected indoor units. Abnormal if the number cannot be checked automatically due to miswiring of indoor/outdoor unit connecting wire and etc. after power is turned on for 4 minutes.</p> <p>2. Abnormal if outdoor controller circuit board recognizes the number of connected indoor units as "2 units or more".</p>	<p>① Contact failure or miswiring of indoor/outdoor unit connecting wire</p> <p>② Diameter or length of indoor/outdoor unit connecting wire is out of specified capacity.</p> <p>③ 2 or more indoor units are connected to one outdoor unit.</p> <p>④ Defective transmitting receiving circuit of outdoor controller circuit board</p> <p>⑤ Defective transmitting receiving circuit of indoor controller board</p> <p>⑥ Defective indoor power board</p> <p>⑦ Do NOT use refrigerant address 0, as 0 is used for FTC (Master). The address range is 1 to 6. (In case of multiple outdoor units control.)</p> <p>⑧ Noise has entered into power supply or indoor/outdoor unit connecting wire.</p>	<p>① Check disconnection or looseness or polarity of indoor/outdoor unit connecting wire of indoor and outdoor units.</p> <p>② Check diameter and length of indoor/outdoor unit connecting wire. Total wiring length: 80 m (including wiring connecting each indoor unit and between indoor and outdoor unit) Also check if the connection order of flat cable is S1, S2, S3.</p> <p>③ Check the number of indoor units that are connected to one outdoor unit. (If EA is detected)</p> <p>④-⑥ Turn the power off once, and on again to check. Replace outdoor controller circuit board, indoor controller board or indoor power board if abnormality occurs again.</p>
Eb (6845)	<p>Miswiring of indoor/outdoor unit connecting wire (converse wiring or disconnection)</p> <p>Outdoor controller circuit board can automatically set the unit number of indoor units.</p> <p>Abnormal if the indoor unit number cannot be set within 4 minutes after power on because of miswiring (converse wiring or disconnection) of indoor/outdoor unit connecting wire.</p>	<p>① Contact failure or miswiring of indoor/outdoor unit connecting wire</p> <p>② Diameter or length of indoor/outdoor unit connecting wire is out of specified capacity.</p> <p>④ Defective transmitting receiving circuit of outdoor controller circuit board</p> <p>⑤ Defective transmitting receiving circuit of indoor controller board</p> <p>⑥ Defective indoor power board</p> <p>⑦ Do NOT use refrigerant address 0, as 0 is used for FTC (Master). The address range is 1 to 6. (In case of multiple outdoor units control.)</p> <p>⑧ Noise has entered into power supply or indoor/outdoor unit connecting wire.</p>	<p>⑦ Check if refrigerant addresses (SW1-3 to SW1-6 on outdoor controller circuit board) are overlapping in case of multiple outdoor units control.</p> <p>⑧ Check transmission path, and remove the cause.</p> <p>Note: The descriptions above, ①-⑧, are for EA, Eb and EC.</p>
EC (6846)	<p>Startup time over</p> <p>The unit cannot finish startup process within 4 minutes after power on.</p>	<p>① Contact failure of indoor/outdoor unit connecting wire</p> <p>② Diameter or length of indoor/outdoor unit connecting wire is out of specified capacity.</p> <p>③ Do NOT use refrigerant address 0, as 0 is used for FTC (Master). The address range is 1 to 6. (In case of multiple outdoor units control.)</p> <p>④ Noise has entered into power supply or indoor/outdoor unit connecting wire.</p>	
EE	<p>Incorrect connection</p> <p>The outdoor unit does not receive the signals of I/F or FTC.</p>	<p>① A device other than Interface unit or Flow temp. controller unit is connected to the unit.</p>	<p>① Connect I/F or FTC to the unit.</p>

<Abnormalities detected while unit is operating>

Check Code	Abnormal point and detection method	Cause	Judgment and action
U1 (1302)	<p>High pressure (High pressure switch 63H operated) Abnormal if high pressure switch 63H operated (4.15 MPa) during compressor operation.</p> <p>63H: High pressure switch</p>	<p>① Defective operation of stop valve (Not fully open) ② Clogged or broken pipe ③ Locked outdoor fan motor ④ Malfunction of outdoor fan motor ⑤ Short cycle of outdoor unit ⑥ Dirt of outdoor heat exchanger ⑦ Decreased airflow caused by defective inspection of outside temperature thermistor (It detects lower temperature than actual temperature.) ⑧ Disconnection or contact failure of connector (63H) on outdoor controller board ⑨ Disconnection or contact failure of 63H connection ⑩ Defective outdoor controller board</p> <p>⑪ Defective action of linear expansion valve ⑫ Malfunction of fan driving circuit</p>	<p>① Check if stop valve is fully open. ② Check piping and repair defect. ③-⑥ Check outdoor unit and repair defect.</p> <p>⑦ Check the detected temperature of outside temperature thermistor on LED display. (SW2 on A-Control Service Tool : Refer to "9-7. FUNCTION OF SWITCHES, CONNECTORS AND JUMPERS".)</p> <p>⑧-⑩ Turn the power off and check F5 is displayed when the power is turned again. When F5 is displayed, refer to "Judgment and action" for F5.</p> <p>⑪ Check linear expansion valve. Refer to "9-4. HOW TO CHECK THE PARTS". ⑫ Replace outdoor controller board.</p>
U2 (1102)	<p>High discharge temperature (1) Abnormal if TH4 exceeds 125°C or 110°C continuously for 5 minutes. Abnormal if TH4 exceeds 110°C or more continuously for 30 seconds after 90 seconds have passed since the defrosting operation started.</p> <p>(2) Abnormal if discharge superheat (Cooling: TH4-T_{63HS} / Heating: TH4-T_{63HS}) exceeds 70°C continuously for 10 minutes.</p> <p>TH4: Thermistor <Discharge></p> <p>High comp. surface temperature Abnormal if TH33 exceeds 125°C. In the case of high comp. surface temperature error, compressor does not restart unless the thermistor (TH33) becomes less than 95°C.</p> <p>TH33: Thermistor <Comp. surface></p>	<p>① Overheated compressor operation caused by shortage of refrigerant ② Defective operation of stop valve ③ Defective thermistor ④ Defective outdoor controller board</p> <p>⑤ Defective action of linear expansion valve ⑥ Clogging with foreign objects in refrigerant circuit Note: Clogging occur in the parts which become below freezing point when water enters in refrigerant circuit. ⑦ In the case of the unit does not restart: Detection temp. of thermistor (TH33) $\geq 95^{\circ}\text{C}$</p>	<p>① Check intake superheat. Check leakage of refrigerant. Charge additional refrigerant. ② Check if stop valve is fully open.</p> <p>③④ Turn the power off and check if U3 is displayed when the power is turned on again. When U3 is displayed, refer to "Judgment and action" for U3.</p> <p>⑤ Check linear expansion valve. Refer to "9-4. HOW TO CHECK THE PARTS". ⑥ After recovering refrigerant, remove water from entire refrigerant circuit under vacuum more than 1 hour.</p>
U3 (5104)	<p>Open/short circuit of outdoor unit temperature thermistor (TH4, TH33) Abnormal if open (3°C or less) or short (217°C or more) is detected during compressor operation. (Detection is inoperative for 10 minutes of compressor starting process and for 10 minutes after and during defrosting.)</p> <p>TH4: Thermistor <Discharge> TH33: Thermistor <Comp. surface></p>	<p>① Disconnection or contact failure of connectors (TH4, TH33) on the outdoor controller circuit board ② Defective thermistor</p> <p>③ Defective outdoor controller circuit board</p>	<p>① Check connection of connector (TH4, TH33) on the outdoor controller circuit board. Check breaking of the lead wire for TH4, TH33. Refer to "9-6. TEST POINT DIAGRAM". ② Check resistance value of TH4, TH33 or temperature by microprocessor. (Thermistor/TH4, TH33: Refer to "9-4. HOW TO CHECK THE PARTS".) (SW2 on A-Control Service Tool: Refer to "9-7. FUNCTION OF SWITCHES, CONNECTORS AND JUMPERS".) ③ Replace outdoor controller board.</p>

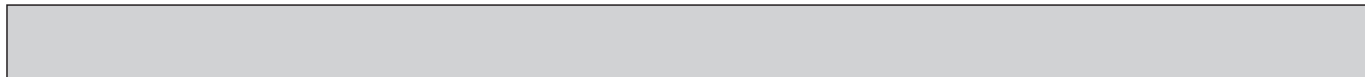

Check code	Abnormal point and detection method	Cause	Judgment and action																				
U4 (TH3:5105) (TH6:5107) (TH7:5106) (TH8:5110) (TH32:5105)* *PUHZ-SHW only	<p>Open/short of outdoor unit thermistors (TH3, TH32 (PUHZ-SHW only), TH6, TH7, and TH8)</p> <p>Abnormal if open or short is detected during compressor operation. Open detection of TH3, TH32 (PUHZ-SHW only) and TH6 is inoperative for 10 seconds to 10 minutes after compressor starting and 10 minutes after and during defrosting.</p> <p>Note: Check which unit has abnormality in its thermistor by switching the mode of SW2. (PAC-SK52ST) (Refer to "9-7. FUNCTION OF SWITCHES, CONNECTORS AND JUMPERS".)</p>	<p>① Disconnection or contact failure of connectors Outdoor controller circuit board: (TH3, TH32 (PUHZ-SHW only), TH7/6) Outdoor power circuit board: CN3</p> <p>② Defective thermistor</p> <p>③ Defective outdoor controller circuit board</p>	<p>① Check connection of connector (TH3, TH32*, TH7/6) on the outdoor controller circuit board. Check connection of connector (CN3) on the outdoor power circuit board. Check breaking of the lead wire for TH3, TH32*, TH6, TH7, TH8. Refer to "9-6.TEST POINT DIAGRAM".</p> <p>② Check resistance value of TH3, TH32*, TH6,TH7,TH8 or check temperature by microprocessor. (TH3,TH6,TH7,TH8: Refer to "9-6.TEST POINT DIAGRAM".) (SW2 on A-Control Service Tool: Refer to "9-7. FUNCTION OF SWITCHES, CONNECTORS AND JUMPERS".)</p> <p>③ Replace outdoor controller circuit board. Note: Emergency operation is available in case of abnormalities of TH3, TH32 (PUHZ-SHW only), TH6 and TH7.</p>																				
Thermistors																							
	<table border="1"> <thead> <tr> <th>Symbol</th> <th>Name</th> <th>Open detection</th> <th>Short detection</th> </tr> </thead> <tbody> <tr> <td>TH3,TH32*</td> <td>Thermistor <Liquid>, <Suction> (PUHZ-SHW only)</td> <td>-40 °C or below</td> <td>90 °C or above</td> </tr> <tr> <td>TH6</td> <td>Thermistor <2-phase pipe></td> <td>-40 °C or below</td> <td>90 °C or above</td> </tr> <tr> <td>TH7</td> <td>Thermistor <Ambient></td> <td>-40 °C or below</td> <td>90 °C or above</td> </tr> <tr> <td>TH8</td> <td>Thermistor <Heat sink></td> <td>-35 °C or below</td> <td>102 °C or above</td> </tr> </tbody> </table>	Symbol	Name	Open detection	Short detection	TH3,TH32*	Thermistor <Liquid>, <Suction> (PUHZ-SHW only)	-40 °C or below	90 °C or above	TH6	Thermistor <2-phase pipe>	-40 °C or below	90 °C or above	TH7	Thermistor <Ambient>	-40 °C or below	90 °C or above	TH8	Thermistor <Heat sink>	-35 °C or below	102 °C or above		
Symbol	Name	Open detection	Short detection																				
TH3,TH32*	Thermistor <Liquid>, <Suction> (PUHZ-SHW only)	-40 °C or below	90 °C or above																				
TH6	Thermistor <2-phase pipe>	-40 °C or below	90 °C or above																				
TH7	Thermistor <Ambient>	-40 °C or below	90 °C or above																				
TH8	Thermistor <Heat sink>	-35 °C or below	102 °C or above																				
U5 (4230)	<p>Temperature of heat sink</p> <p>Abnormal if TH8 detects temperature indicated below. SW75, 100V, SHW80, 112V.....78°C SW75, 100Y, SHW80, 112Y.....85°C</p> <p>TH8: Thermistor <Heat sink></p>	<p>① The outdoor fan motor is locked. ② Failure of outdoor fan motor ③ Air flow path is clogged. ④ Rise of ambient temperature</p> <p>⑤ Defective thermistor</p> <p>⑥ Defective input circuit of outdoor power circuit board ⑦ Failure of outdoor fan drive circuit</p>	<p>①② Check outdoor fan.</p> <p>③ Check air flow path for cooling. ④ Check if there is something which causes temperature rise around outdoor unit. (Upper limit of ambient temperature is 46°C.) Turn off power, and on again to check if U5 is displayed within 30 minutes. If U4 is displayed instead of U5, follow the action to be taken for U4.</p> <p>⑤ Check resistance value of TH8 or temperature by microprocessor. (TH8: Refer to "9-4. HOW TO CHECK THE PARTS".) (SW2 on A-Control Service Tool: Refer to "9-7. FUNCTION OF SWITCHES, CONNECTORS AND JUMPERS".)</p> <p>⑥ Replace outdoor power circuit board. ⑦ Replace outdoor controller circuit board.</p>																				
U6 (4250)	<p>Power module</p> <p>Check abnormality by driving power module in case overcurrent is detected. (UF or UP error condition)</p>	<p>① Outdoor stop valve is closed. ② Decrease of power supply voltage ③ Looseness, disconnection or converse of compressor wiring connection ④ Defective compressor ⑤ Defective outdoor power circuit board</p>	<p>① Open stop valve. ② Check facility of power supply. ③ Correct the wiring (U-V-W phase) to compressor. Refer to "9-6. TEST POINT DIAGRAM" (Outdoor power circuit board). ④ Check compressor referring to "9-4. HOW TO CHECK THE PARTS". ⑤ Replace outdoor power circuit board.</p>																				
U7 (1520)	<p>Too low superheat due to low discharge temperature</p> <p>Abnormal if discharge superheat is continuously detected less than or equal to -15°C for 3 minutes even though linear expansion valve has minimum open pulse after compressor starts operating for 10 minutes.</p>	<p>① Disconnection or loose connection of discharge temperature thermistor (TH4) ② Defective holder of discharge temperature thermistor ③ Disconnection or loose connection of linear expansion valve's coil ④ Disconnection or loose connection of linear expansion valve's connector ⑤ Defective linear expansion valve</p>	<p>①② Check the installation conditions of discharge temperature thermistor (TH4).</p> <p>③ Check the coil of linear expansion valve. Refer to "9-5. HOW TO CHECK THE COMPONENTS".</p> <p>④ Check the connection or contact of LEV-A and LEV-B on outdoor controller circuit board. ⑤ Check linear expansion valve. Refer to "9-4. HOW TO CHECK THE PARTS".</p>																				
U8 (4400)	<p>Outdoor fan motor</p> <p>Abnormal if rotational frequency of the fan motor is not detected during DC fan motor operation. Fan motor rotational frequency is abnormal if;</p> <ul style="list-style-type: none"> • 100 rpm or below detected continuously for 15 seconds at 20°C or more outside air temperature. • 50 rpm or below or 1500 rpm or more detected continuously for 1 minute. 	<p>① Failure in the operation of the DC fan motor ② Failure in the outdoor circuit controller board</p>	<p>① Check or replace the DC fan motor.</p> <p>② Check the voltage of the outdoor circuit controller board during operation. ③ Replace the outdoor circuit controller board. (When the failure is still indicated even after performing the action ① above.)</p>																				



Check code	Abnormal point and detection method	Cause	Judgment and action	
U9 (4220)	Detailed codes	To find out the details about U9 error, turn ON SW2-1, 2-2, 2-3, 2-4, 2-5 and 2-6 when U9 error occurs. To find out the detail history (latest) about U9 error, turn ON SW2-1, 2-2 and 2-6. Refer to "9-7. FUNCTION OF SWITCHES, CONNECTORS AND JUMPERS".		
	01	Overvoltage error • Increase in DC bus voltage to SW75,100V,SHW80, 112V: 430V SW75,100Y,SHW80, 112Y: 760V	① Abnormal increase in power source voltage ② Disconnection of compressor wiring ③ Defective outdoor power circuit board ④ Compressor has a ground fault.	① Check the field facility for the power supply. ② Correct the wiring (U-V-W phase) to compressor. Refer to "9-7. FUNCTION OF SWITCHES, CONNECTORS AND JUMPERS". (Outdoor power circuit board). ③ Replace outdoor power circuit board. ④ Check compressor for electrical insulation. Replace compressor.
	02	Undervoltage error • Instantaneous decrease in DC bus voltage to SW75, 100V, SHW80, 112V: 200V SW75, 100Y, SHW80, 112Y: 350V	① Decrease in power source voltage, instantaneous stop ② Defective converter drive circuit in outdoor power circuit board (SW-V, SHW-V) ③ Defective 52C drive circuit in outdoor power circuit board ④ Defective outdoor converter circuit board (SW-Y, SHW-Y) ⑤ Disconnection or loose connection of rush current protect resistor RS (SW-Y, SHW-Y) ⑥ Defective rush current protect resistor RS (SW-Y, SHW-Y) ⑦ Disconnection or loose connection of CN2 on the outdoor power circuit board /controller circuit board (SW-V, SHW-V) ⑧ Power circuit failure on DC supply for 15 V DC output on outdoor controller circuit board (SW-V, SHW-V)	① Check the field facility for the power supply. ② Replace outdoor power circuit board. (SW-V, SHW-V) ③ Replace outdoor power circuit board. ④ Replace outdoor converter circuit board. (SW-Y, SHW-Y) ⑤ Check RS wiring. (SW-Y, SHW-Y) ⑥ Replace RS. (SW-Y, SHW-Y) ⑦ Check CN2 wiring. (SW-V, SHW-V) ⑧ Replace outdoor controller circuit board. (SW-V, SHW-V)
	04	Input current sensor error/ L1-phase open error • Decrease in input current through outdoor unit to 0.1A only if operation frequency is more than or equal to 40Hz or compressor current is more than or equal to 6A.	① L1-phase open (SW-Y, SHW-Y) ② Disconnection or loose connection between TB1 and outdoor noise filter circuit board (SW-Y, SHW-Y) ③ Disconnection or loose connection of CN5 on the outdoor power circuit board/CNCT on the outdoor noise filter board ④ Defective ACCT (AC current trans) on the outdoor noise filter circuit board (SW-Y, SHW-Y) ⑤ Defective input current detection circuit in outdoor power circuit board ⑥ Defective outdoor controller circuit board	① Check the field facility for the power supply. (SW-Y, SHW-Y) ② Check the wiring between TB1 and outdoor noise filter circuit board. (SW-Y, SHW-Y) ③ Check CN5/CNCT wiring. (SW-Y, SHW-Y) ④ Replace outdoor noise filter circuit board. (SW-Y, SHW-Y) ⑤ Replace outdoor power circuit board. ⑥ Replace outdoor controller circuit board.
08	Abnormal power synchronous signal • No input of power synchronous signal to power circuit board • Power synchronous signal of 44 Hz or less, or 65 Hz or more is detected on power circuit board.	① Distortion of power source voltage, noise superimposition. ② Disconnection or loose connection of earth wiring ③ Disconnection or loose connection of CN2 on the outdoor power circuit board /controller circuit board ④ Defective power synchronous signal circuit in outdoor controller circuit board ⑤ Defective power synchronous signal circuit in outdoor power circuit board	① Check the field facility for the power supply. ② Check earth wiring. ③ Check CN2 wiring. ④ Replace outdoor controller circuit board. ⑤ Replace outdoor power circuit board.	

Continue to the next page

From the previous page.

Check code	Abnormal point and detection method	Cause	Judgment and action	
U9 (4220)	Detailed codes	PFC error (Overvoltage/Undervoltage/Overcurrent) • PFC detected any of the following a) Increase of DC bus voltage to 430 V. b) Decrease in PFC control voltage to 12 V DC or lower c) Increase in input current (SW-V, SHW-V only)	① Abnormal increase in power source voltage ② Decrease in power source voltage, instantaneous stop ③ Disconnection of compressor wiring ④ Misconnection of reactor (DCL1-3) ⑤ Defective outdoor power circuit board ⑥ Defective reactor (DCL1-3) ⑦ Disconnection or loose connection of CN2 on the outdoor power circuit board/controller circuit board	①② Check the field facility for the power supply. ③ Correct the wiring (U•V•W phase) to compressor. Refer to "9-6. TEST POINT DIAGRAM". (Outdoor power circuit board). ④ Correct the wiring of reactor (DCL1-3). ⑤ Replace outdoor power circuit board. ⑥ Replace reactor (DCL1-3). ⑦ Check CN2 wiring.
	10			
U9 (4220)	Detailed codes	PFC/IGBT error (Undervoltage) • When Compressor is running, DC bus voltage stays at 310 V or lower for consecutive 10 seconds (SW75, 100V, SHW80, 112V only)	① Incorrect switch settings on the outdoor controller circuit board for model select ② Defective outdoor power circuit board ③ Defective outdoor controller circuit board	① Correction of a model select ② Replace outdoor power circuit board. ③ Replace outdoor controller circuit board.
	20			
Ud (1504)	Overheat protection Abnormal if TH3, condensing temperature T _{63HS} detects 70°C or more during compressor operation. TH3: Thermistor <Liquid>	① Defective outdoor fan (fan motor) or short cycle of outdoor unit during cooling operation ② Defective TH3, condensing temperature T _{63HS} ③ Defective outdoor controller board	① Check outdoor unit air passage. ②③ Turn the power off and on again to check the check code. If U4 is displayed, follow the U4 processing direction.	
UE (1302)	Abnormal pressure of 63HS Abnormal if 63HS detects 0.1 MPa or less. Detection is inoperative for 3 minutes after compressor starting and 3 minutes after and during defrosting. 63HS: High pressure sensor	① Disconnection or contact failure of connector (63HS) on the outdoor controller circuit board ② Defective pressure sensor ③ Defective outdoor controller circuit board	① Check connection of connector (63HS) on the outdoor controller circuit board. Check breaking of the lead wire for 63HS. ② Check pressure by microprocessor. (Pressure sensor/ 63HS) (SW2: Refer to "9-7. FUNCTION OF SWITCHES, CONNECTORS AND JUMPERS".) ③ Replace outdoor controller board.	
UF (4100)	Compressor overcurrent interruption (When compressor locked) Abnormal if overcurrent of DC bus or compressor is detected within 30 seconds after compressor starts operating.	① Stop valve is closed. ② Decrease of power supply voltage ③ Looseness, disconnection or converse of compressor wiring connection ④ Defective compressor ⑤ Defective outdoor power board	① Open stop valve. ② Check facility of power supply. ③ Correct the wiring (U•V•W phase) to compressor. Refer to "9-6. TEST POINT DIAGRAM". (Outdoor power circuit board). ④ Check compressor. Refer to "9-4. HOW TO CHECK THE PARTS". ⑤ Replace outdoor power circuit board.	
UH (5300)	Current sensor error or input current error • Abnormal if current sensor detects -1.0A to 1.0A during compressor operation. (This error is ignored in case of test run mode.) • Abnormal if 40A (SW75, 100V, SHW80, 112V) of input current is detected or 37A (SW75, 100V, SHW80, 112V) or more of input current is detected for 10 seconds continuously.	① Disconnection of compressor wiring ② Defective circuit of current sensor on outdoor power circuit board ③ Decrease of power supply voltage ④ Leakage or shortage of refrigerant	① Correct the wiring (U•V•W phase) to compressor. Refer to "9-6. TEST POINT DIAGRAM" (Outdoor power circuit board). ② Replace outdoor power circuit board. ③ Check the facility of power supply. ④ Check leakage of refrigerant.	
UL (1300)	Low pressure (63L operated)(SW100/SHW80/SHW112 only) Abnormal if 63L is operated (under -0.03MPa) during compressor operation. 63L: Low pressure switch	① Stop valve of outdoor unit is closed during operation. ② Disconnection or loose connection of connector (63L) on outdoor controller board ③ Disconnection or loose connection of 63L ④ Defective outdoor controller board ⑤ Leakage or shortage of refrigerant ⑥ Malfunction of linear expansion valve	① Check stop valve. ②-④ Turn the power off and on again to check if F3 is displayed on restarting. If F3 is displayed, follow the F3 processing direction. ⑤ Correct to proper amount of refrigerant. ⑥ Check linear expansion valve. Refer to "9-4. HOW TO CHECK THE PARTS".	



Check code	Abnormal point and detection method	Cause	Judgment and action
UP (4210)	<p>Compressor overcurrent interruption Abnormal if overcurrent DC bus or compressor is detected after compressor starts operating for 30 seconds.</p>	<p>① Stop valve of outdoor unit is closed. ② Decrease of power supply voltage ③ Looseness, disconnection or converse of compressor wiring connection ④ Defective fan of indoor/outdoor units ⑤ Short cycle of indoor/outdoor units ⑥ Defective input circuit of outdoor controller board</p> <p>⑦ Defective compressor ⑧ Defective outdoor power circuit board ⑨ DIP switch setting difference of outdoor controller circuit board</p>	<p>① Open stop valve. ② Check facility of power supply. ③ Correct the wiring (U-V-W phase) to compressor. Refer to "9-6.TEST POINT DIAGRAM" (Outdoor power circuit board). ④ Check indoor/outdoor fan. ⑤ Solve short cycle. ⑥ Replace outdoor controller circuit board. Note: Before the replacement of the outdoor controller circuit board, disconnect the wiring to compressor from the outdoor power circuit board and check the output voltage among phases, U, V, W, during test run. No defect on board if voltage among phases (U-V, V-W and W-U) is same. Make sure to perform the voltage check with same performing frequency. ⑦ Check compressor. Refer to "9-4. HOW TO CHECK THE PARTS". ⑧ Replace outdoor power circuit board. ⑨ Check the DIP switch setting of outdoor controller circuit board.</p>
E0 or E4 (6831 or 6834)	<p>Remote controller transmission error (E0)/ signal receiving error (E4) ① Abnormal if main remote controller cannot receive normally any transmission from indoor unit of refrigerant address "0" for 3 minutes. (Check code: E0)</p> <p>② Abnormal if indoor controller board cannot receive normally any data from remote controller board or from other indoor controller board for 3 minutes. (Check code: E4)</p> <p>③ Indoor controller board cannot receive any signal from remote controller for 2 minutes. (Check code: E4)</p>	<p>① Contact failure at transmission wire of remote controller</p> <p>② Miswiring of remote controller</p> <p>③ Defective transmitting receiving circuit of remote controller ④ Defective transmitting receiving circuit of indoor controller board of refrigerant address "0" ⑤ Noise has entered into the transmission wire of remote controller.</p>	<p>① Check disconnection or looseness of indoor unit or transmission wire of remote controller. ② Check wiring of remote controller. • Total wiring length: Max. 500 m (Do not use cable × 3 or more.) • The number of connecting indoor units: Max. 6 units • The number of connecting remote controller: Max. 1 unit If the cause of trouble is not in above ①–③, ③ Diagnose remote controller (PAC-IF011B-E only). a) When "RC OK" is displayed, Remote controllers have no problem. Turn the power off, and on again to check. If abnormality generates again, replace indoor controller board. b) When "RC NG" is displayed, Replace remote controller. c) When "RCE3" or "ERC00-66" is displayed, noise may be causing abnormality. Note: If the unit is not normal after replacing indoor controller board in group control, indoor controller board of address "0" may be abnormal. For the controllers other than PAC-IF011B-E, refer to Installation Manual or Service Handbook of the indoor unit.</p>
E1 or E2 (6201 or 6202)	<p>Remote controller control board ① Abnormal if data cannot be normally read from the nonvolatile memory of the remote controller control board. (Check code: E1) ② Abnormal if the clock function of remote controller cannot be normally operated. (Check code: E2)</p>	<p>① Defective remote controller</p>	<p>① Replace remote controller.</p>



Check code	Abnormal point and detection method	Cause	Judgment and action
E3 or E5 (6832 or 6833)	Remote controller transmission error (E3)/ signal receiving error (E5) ① Abnormal if remote controller could not find blank of transmission path for 6 seconds and could not transmit. (Check code: E3) ② Remote controller receives transmitted data at the same time, compares the data, and when detecting it, judges different data to be abnormal 30 continuous times. (Check code: E3) ① Abnormal if indoor controller board could not find blank of transmission path. (Check code: E5) ② Indoor controller board receives transmitted data at the same time, compares the data, and when detecting it, judges different data to be abnormal 30 continuous times. (Check code: E5)	① Duplication of refrigerant address ② Defective transmitting receiving circuit of remote controller ③ Defective transmitting receiving circuit of indoor controller board ④ Noise has entered into transmission wire of remote controller.	① The address changes to a separate setting. ②-④ Diagnose remote controller (PAC-IF011B-E only). a) When "RC OK" is displayed, remote controllers have no problem. Turn the power off, and on again to check. When becoming abnormal again, replace indoor controller board. b) When "RC NG" is displayed, replace remote controller. c) When "RC E3" or "ERC 00-66" is displayed, noise may be causing abnormality. Note: For the controllers other than PAC-IF011B-E, refer to Installation Manual or Service Handbook of the indoor unit.
E8 (6840)	Indoor/outdoor unit communication error (Signal receiving error) (Outdoor unit) Abnormal if outdoor controller circuit board could not receive anything normally for 3 minutes.	① Contact failure of indoor/outdoor unit connecting wire ② Defective communication circuit of outdoor controller circuit board ③ Defective communication circuit of indoor controller board ④ Noise has entered into indoor/outdoor unit connecting wire.	① Check disconnection or looseness of indoor/outdoor unit connecting wire of indoor or outdoor units. ②-④ Turn the power off, and on again to check. Replace indoor controller board or outdoor controller circuit board if abnormality is displayed again.
E9 (6841)	Indoor/outdoor unit communication error (Transmitting error) (Outdoor unit) ① Abnormal if "0" receiving is detected 30 times continuously though outdoor controller circuit board has transmitted "1". ② Abnormal if outdoor controller circuit board could not find blank of transmission path for 3 minutes.	① Indoor/ outdoor unit connecting wire has contact failure. ② Defective communication circuit of outdoor controller circuit board ③ Noise has entered power supply. ④ Noise has entered indoor/outdoor unit connecting wire.	① Check disconnection or looseness of indoor/outdoor unit connecting wire. ②-④ Turn the power off, and on again to check. Replace outdoor controller circuit board if abnormality is displayed again.
EF (6607 or 6608)	Non defined check code This code is displayed when non defined check code is received.	① Noise has entered transmission wire of remote controller. ② Noise has entered indoor/outdoor unit connecting wire. ③ Outdoor unit is not inverter models.	①② Turn the power off, and on again to check. Replace indoor controller board or outdoor controller circuit board if abnormality is displayed again. ③ Replace outdoor unit with inverter type outdoor unit.
Ed (0403)	Serial communication error ① Abnormal if serial communication between outdoor controller circuit board and outdoor power circuit board is defective.	① Breaking of wire or contact failure of connector CN2 between the outdoor controller circuit board and the outdoor power circuit board ② Breaking of wire or contact failure of connector CN4 between the outdoor controller circuit board and the outdoor power circuit board ③ Defective communication circuit of outdoor power circuit board ④ Defective communication circuit of outdoor controller circuit board for outdoor power circuit board	①② Check connection of each connector CN2 and CN4 between the outdoor controller circuit board and the outdoor power circuit board. ③ Replace outdoor power circuit board. ④ Replace outdoor controller circuit board.





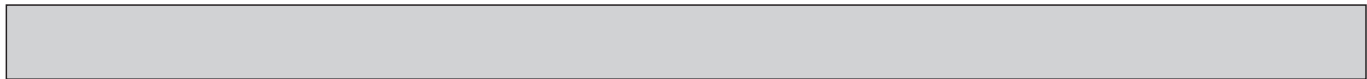

Check code	Abnormal point and detection method	Cause	Judgment and action
P8	<p>Pipe temperature <Cooling mode> Detected as abnormal when the pipe temperature is not in the cooling range 3 minutes after compressor start and 6 minutes after the liquid or condenser/evaporator pipe is out of cooling range. Note 1: It takes at least 9 minutes to detect. Note 2: Abnormality P8 is not detected in drying mode. Cooling range: Indoor pipe temperature (TH2 or TH5) – room temperature (TH1) $\leq -3^{\circ}\text{C}$ TH: Lower temperature between liquid pipe temperature and condenser/evaporator temperature</p> <p><Heating mode> When 10 seconds have passed after the compressor starts operation and the hot adjustment mode has finished, the unit is detected as abnormal when condenser/evaporator pipe temperature is not in heating range within 20 minutes.</p> <p>Note 3: It takes at least 27 minutes to detect abnormality. Note 4: It excludes the period of defrosting (Detection restarts when defrosting mode is over) Heating range : $3^{\circ}\text{C} \leq (\text{Condenser/ Evaporator temperature(TH5)} - \text{room temperature(TH1)})$</p>	<p>① Slight temperature difference between indoor room temperature and pipe <liquid or condenser/evaporator> temperature thermistor</p> <ul style="list-style-type: none"> • Shortage of refrigerant • Disconnected holder of pipe <liquid or condenser/evaporator> thermistor • Defective refrigerant circuit <p>② Converse connection of extension pipe (on plural units connection)</p> <p>③ Converse wiring of indoor/outdoor unit connecting wire (on plural units connection)</p> <p>④ Defective detection of indoor room temperature and pipe <condenser/evaporator> temperature thermistor</p> <p>⑤ Stop valve is not opened completely.</p>	<p>①—④ Check pipe <liquid or condenser/evaporator> temperature with room temperature display on remote controller and outdoor controller circuit board. Pipe <liquid or condenser/ evaporator> temperature display is indicated by setting SW2 of outdoor controller circuit board as follows.</p> <p>(Conduct temperature check with outdoor controller circuit board after connecting 'A-Control Service Tool (PAC-SK52ST)')</p> <div style="display: flex; justify-content: space-around;"> <div style="text-align: center;"> <p>Temperature display of indoor liquid pipe Indoor 1</p> </div> <div style="text-align: center;"> <p>Temperature display of indoor condenser/evaporator pipe Indoor 1</p> </div> </div> <div style="display: flex; justify-content: space-around; margin-top: 10px;"> <div style="text-align: center;"> <p>Temperature display of indoor liquid pipe Indoor 2</p> </div> <div style="text-align: center;"> <p>Temperature display of indoor condenser/evaporator pipe Indoor 2</p> </div> </div> <p style="text-align: center; font-size: small;">A-Control Service Tool SW2 setting</p> <p>②③ Check converse connection of extension pipe or converse wiring of indoor/outdoor unit connecting wire.</p>

9-3. TROUBLESHOOTING OF PROBLEMS

Phenomena	Factor	Countermeasure
1. Remote controller display does not work.	<p>① 12 V DC is not supplied to remote controller.</p> <p>② 12–15 V DC is supplied to remote controller, however, no display is indicated.</p> <ul style="list-style-type: none"> • "PLEASE WAIT" is not displayed. • "PLEASE WAIT" is displayed. 	<p>① Check LED2 on indoor controller board.</p> <p>(1) When LED2 is lit. Check the remote controller wiring for breaking or contact failure.</p> <p>(2) When LED2 is blinking. Check short circuit of remote controller wiring.</p> <p>(3) When LED2 is not lit. Refer to No.3 below.</p> <p>② Check the following.</p> <ul style="list-style-type: none"> • Failure of remote controller if "PLEASE WAIT" is not displayed • Refer to No.2 below if "PLEASE WAIT" is displayed.
2. "PLEASE WAIT" display is remained on the remote controller.	<p>① At longest 2 minutes after the power supply "PLEASE WAIT" is displayed to start up.</p> <p>② Communication error between the remote controller and indoor unit</p> <p>③ Communication error between the indoor and outdoor unit</p> <p>④ Outdoor unit protection device connector is open.</p>	<p>① Normal operation</p> <p>② Self-diagnosis of remote controller</p> <p>③ "PLEASE WAIT" is displayed for 6 minutes at most in case of indoor/outdoor unit communication error. Check LED3 on indoor controller board.</p> <p>(1) When LED3 is not blinking. Check indoor/outdoor connecting wire for miswiring. (Converse wiring of S1 and S2, or break of S3 wiring.)</p> <p>(2) When LED3 is blinking. Indoor/outdoor connecting wire is normal.</p> <p>④ Check LED display on outdoor controller circuit board. Refer to "9-9.TEST POINT DIAGRAM". Check protection device connector (63L and 63H) for contact failure.</p>
3. When pressing the remote controller operation switch, the OPERATION display is appeared but it will be turned off soon.	<p>① After cancelling to select function from the remote controller, the remote controller operation switch will be not accepted for approx. 30 seconds.</p>	<p>① Normal operation</p>
4. Remote controller display works normally and the unit performs cooling operation, however, the capacity cannot be fully obtained.	<p>① Refrigerant shortage</p> <p>② Filter clogging</p>	<p>① If refrigerant leaks, discharging temperature rises and LEV opening increases. Inspect leakage by checking the temperature and opening. Check pipe connections for gas leakage.</p> <p>② Clean the filter of water piping.</p>
5. Remote controller display works normally and the unit performs heating operation, however, the capacity cannot be fully obtained.	<p>① Linear expansion valve fault Opening cannot be adjusted well due to linear expansion valve fault.</p> <p>② Refrigerant shortage</p> <p>③ Lack of insulation for refrigerant piping</p> <p>④ Filter clogging</p> <p>⑤ Bypass circuit of outdoor unit fault</p>	<p>① Discharging temperature and indoor heat exchanger temperature does not rise. Inspect the failure by checking discharging pressure. Replace linear expansion valve.</p> <p>② If refrigerant leaks, discharging temperature rises and LEV opening increases. Inspect leakage by checking the temperature and opening. Check pipe connections for gas leakage.</p> <p>③ Check the insulation.</p> <p>④ Clean the filter of water piping.</p> <p>⑤ Check refrigerant system during operation.</p>
6. ① For 3 minutes after temperature adjuster turns off, the compressor will not start operating even if temperature adjuster is turned on. ② For 3 minutes after temperature adjuster turns on, the compressor will not stop operating even if temperature adjuster is turned off. (Compressor stops operating immediately when turning off by the remote controller.)	<p>①② Normal operation (For protection of compressor)</p>	<p>①② Normal operation</p>



Phenomena	Countermeasure
A flowing water sound or occasional hissing sound is heard.	<ul style="list-style-type: none"> These sounds can be heard when refrigerant and/or water is (are) flowing in the indoor unit or refrigerant pipe, or when the refrigerant and/or water is (are) chugging.
Water does not heat or cool well.	<ul style="list-style-type: none"> Clean the filter of water piping. (Flow is reduced when the filter is dirty or clogged.) Check the temperature adjustment and adjust the set temperature. Make sure that there is plenty of space around the outdoor unit.
Water or vapour is emitted from the outdoor unit.	<ul style="list-style-type: none"> During cooling mode, water may form and drip from the cool pipes and joints. During heating mode, water may form and drip from the heat exchanger of outdoor unit. During defrosting mode, water on the heat exchanger of outdoor unit evaporates and water vapour may be emitted.
The operation indicator does not appear in the remote controller display.	<ul style="list-style-type: none"> Turn on the power switch. "●" will appear in the remote controller display*.
"  appears in the remote controller display.*	<ul style="list-style-type: none"> During external signal control, "
When restarting the outdoor unit soon after stopping it, it does not operate even though the ON/OFF button is pressed.*	<ul style="list-style-type: none"> Wait approximately 3 minutes. (Operation has stopped to protect the outdoor unit.)
FTC operates without the ON/OFF button being pressed.*	<ul style="list-style-type: none"> Is the on timer set? Press the ON/OFF button to stop operation. Is the FTC connected to a external signal? Consult the concerned people who control the FTC. Does " appear in the remote controller display? Consult the concerned people who control the FTC. Has the auto recovery feature from power failures been set? Press the ON/OFF button to stop operation.
FTC stops without the ON/OFF button being pressed.*	<ul style="list-style-type: none"> Is the off timer set? Press the ON/OFF button to restart operation. Is the FTC connected to a central remote controller? Consult the concerned people who control the FTC. Does " appear in the remote controller display? Consult the concerned people who control the FTC.
Remote controller timer operation cannot be set.*	<ul style="list-style-type: none"> Are timer settings invalid? If the timer can be set, (WEEKLY), (SIMPLE), or (AUTO OFF) appears in the remote controller display.
"PLEASE WAIT" appears in the remote controller display.	<ul style="list-style-type: none"> The initial settings are being performed. Wait approximately 3 minutes. If the remote controller is not only for FTC, change it.
A check code appears in the remote controller display.	<ul style="list-style-type: none"> The protection devices have operated to protect the FTC and outdoor unit. Do not attempt to repair this equipment by yourself. Turn off the power switch immediately and consult your dealer. Be sure to provide the dealer with the model name and information that appeared in the remote controller display.

*PAC-IF011B-E only

• If the unit cannot be operated properly after test run, refer to the following table to find the cause.

Symptom		Cause
Wired remote controller	LED 1, 2 (PCB in outdoor unit)	
PLEASE WAIT	For about 2 minutes after power-on	After LED 1, 2 are lighted, LED 2 is turned off, then only LED 1 is lighted. (Correct operation)
PLEASE WAIT → Check code	Subsequent to about 2 minutes after power-on	Only LED 1 is lighted. → LED 1, 2 blink.
Display messages do not appear even when operation switch is turned ON (operation lamp does not light up).		Only LED 1 is lighted. → LED 1 blinks twice, LED 2 blinks once.

Note: Operation is not possible for about 30 seconds after cancellation of function selection. (Correct operation)

For description of each LED (LED1, 2, 3) provided on the FTC, refer to the following table.

LED1 (power for microprocessor)	Indicates whether control power is supplied. Make sure that this LED is always lit.
LED2 (power for remote controller)	Indicates whether power is supplied to the remote controller. This LED lights only in the case of the FTC which is connected to the outdoor unit refrigerant addresses "0".
LED3 (communication between FTC and outdoor units)	Indicates state of communication between the FTC and outdoor units. Make sure that this LED is always blinking.

Symptoms: “PLEASE WAIT” is kept being displayed on the remote controller.

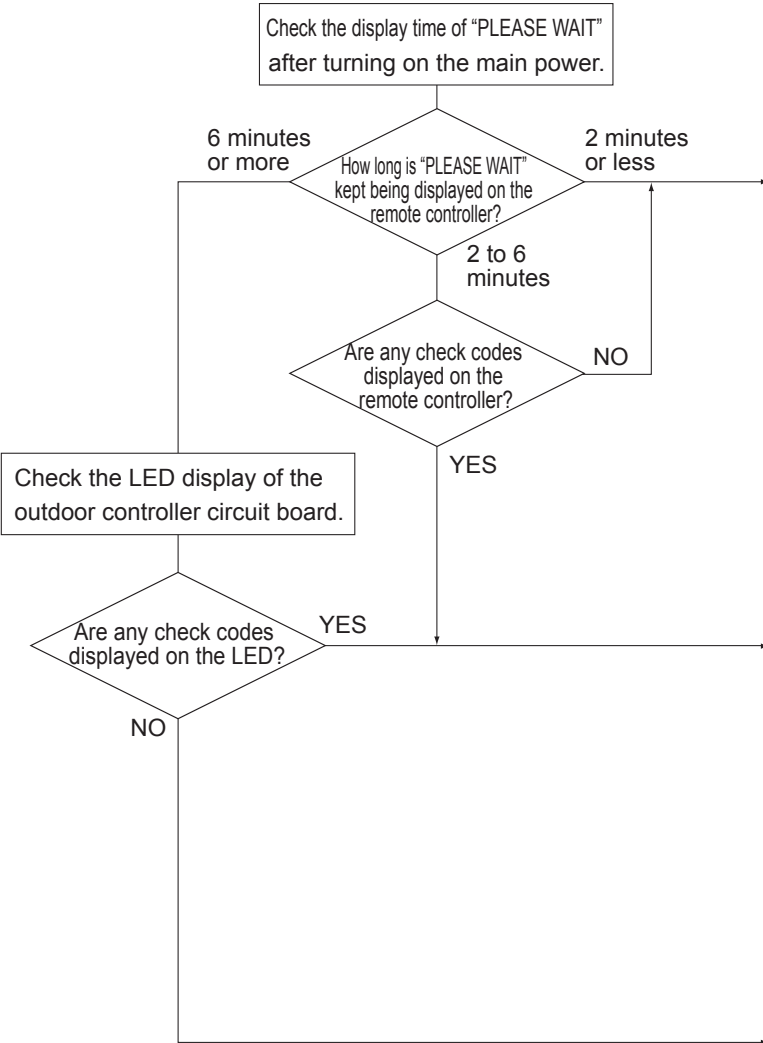



Diagnosis flow	Cause	Inspection method and troubleshooting
 <pre> graph TD Start[Check the display time of "PLEASE WAIT" after turning on the main power.] --> D1{How long is "PLEASE WAIT" kept being displayed on the remote controller?} D1 -- "6 minutes or more" --> Step1[Check the LED display of the outdoor controller circuit board.] D1 -- "2 to 6 minutes" --> D2{Are any check codes displayed on the remote controller?} D1 -- "2 minutes or less" --> End1["• "PLEASE WAIT" will be displayed during the start-up diagnosis after turning on the main power."] D2 -- YES --> End2["• Miswiring of indoor/outdoor connecting wire • Breaking of indoor/outdoor connecting wire (S3) • Defective indoor controller board • Defective outdoor controller circuit board"] D2 -- NO --> End1 Step1 --> D3{Are any check codes displayed on the LED?} D3 -- YES --> End2 D3 -- NO --> End3["• Defective indoor controller board • Defective remote controller"] </pre>	<ul style="list-style-type: none"> • “PLEASE WAIT” will be displayed during the start-up diagnosis after turning on the main power. • Miswiring of indoor/outdoor connecting wire • Breaking of indoor/outdoor connecting wire (S3) • Defective indoor controller board • Defective outdoor controller circuit board • Defective indoor controller board • Defective remote controller 	<ul style="list-style-type: none"> • Normal. The start-up diagnosis will be over in around 2 minutes. • Refer to “Self-diagnosis action table” in order to solve the trouble. • In case of communication errors, the display of remote controller may not match the LED display of the outdoor unit.

Symptoms: Nothing is displayed on the remote controller. ①

LED display of the indoor controller board
 LED1 : ○
 LED2 : ○
 LED3 : ○

Diagnosis flow	Cause	Inspection method and troubleshooting
<pre> graph TD Start[Check the voltage between S1 and S2 on the terminal block of the indoor unit which is used to connect the indoor unit and the outdoor unit.] --> D1{198 to 264 V AC?} D1 -- YES --> C1[The fuses on the indoor controller circuit board are blown. Defective indoor controller board] D1 -- NO --> S2[Check the voltage among L(L3) and N on the terminal block (TB1) of the outdoor power circuit board.] S2 --> D2{198 to 264 V AC?} D2 -- NO --> C2[• Troubles concerning power supply] D2 -- YES --> S3[Check the voltage between S1 and S2 on the terminal block (TB1) of the outdoor unit which is used to connect the indoor unit and the outdoor unit.] S3 --> D3{198 to 264 V AC?} D3 -- NO --> C3[• Bad wiring of the outdoor controller board • The fuses on the outdoor controller circuit board are blown.] D3 -- YES --> C4[• Bad wiring of the outdoor controller board • The fuses on the outdoor controller circuit board are blown.] </pre>	<ul style="list-style-type: none"> • Troubles concerning power supply • Bad wiring of the outdoor controller board • The fuses on the outdoor controller circuit board are blown. • Bad wiring of the outdoor controller board • The fuses on the outdoor controller circuit board are blown. • The fuses on the indoor controller circuit board are blown. • Defective indoor controller board 	<ul style="list-style-type: none"> • Check the power wiring to the outdoor unit. • Check the breaker. • Check the wiring of the outdoor unit. • Check if the wiring is bad. Check if the fuses are blown. The fuses on the outdoor controller circuit board will be blown when the indoor /outdoor connecting wire short-circuits. • Check if miswiring, breaking or poor contact is causing this problem. Indoor/outdoor connecting wire is polarized 3-core type. Connect the indoor unit and the outdoor unit by wiring each pair of S1, S2 and S3 on the both side of indoor/outdoor terminal blocks. • Check if the fuses are blown. • Replace the indoor controller board.

Symptoms: Nothing is displayed on the remote controller. ②

LED display of the indoor controller board
 LED1 : 
 LED2 : 
 LED3 :  or 

Diagnosis flow	Cause	Inspection method and troubleshooting
<p>Check the voltage between S1 and S2 on the terminal block of the indoor unit which is used to connect the indoor unit and the outdoor unit.</p> <p>198 to 264 V AC?</p> <p>NO → Check the looseness or disconnection of the indoor/outdoor connecting wire.</p> <p>YES → Check the status of the indoor controller board LED3 display.</p> <p>Not lighting. → Check the looseness or disconnection of the indoor/outdoor connecting wire.</p> <p>Blinking. → Are there looseness or disconnection of the indoor/outdoor connecting wire?</p> <p>NO → Check the refrigerant address of the outdoor unit. (SW1-3 to 1-6)</p> <p>Is the refrigerant address "0"?</p> <p>NO → Defective outdoor controller circuit board</p> <p>YES → Check the LED display of the outdoor unit after turning on the main power again.</p> <p>Is anything displayed?</p> <p>Not displayed. → Defective outdoor controller circuit board</p> <p>Displayed. → Is "EA" or "Eb" displayed?</p> <p>NO → Is "E8" displayed?</p> <p>YES → Defective outdoor controller circuit board</p> <p>NO → Can the unit be restarted?</p> <p>NO → Can all the indoor unit be operated?</p> <p>NO → Defective indoor controller board</p> <p>YES → Check the voltage between S2 and S3 on the terminal block of the outdoor unit.</p> <p>17 to 28 V DC?</p> <p>NO → Influence of electromagnetic noise</p> <p>YES → Defective outdoor power circuit board</p> <p>YES → Defective indoor power board</p>	<ul style="list-style-type: none"> • Breaking or poor contact of the indoor/outdoor connecting wire • Normal Only the unit which has the refrigerant address "0" supplies power to the remote controller • Defective outdoor controller circuit board • Defective outdoor controller circuit board • Defective indoor controller board • Influence of electromagnetic noise • Defective outdoor power circuit board • Defective indoor power board 	<ul style="list-style-type: none"> • Fix the breaking or poor contact of the indoor/outdoor connecting wire. • Set the refrigerant address to "0". In case of the multiple outdoor units control, recheck the refrigerant address again. • Replace the outdoor controller circuit board. • Replace the outdoor controller circuit board. • Replace the indoor controller board of the indoor unit which does not operate. • Not abnormal. There may be the influence of electromagnetic noise. Check the transmission wire and get rid of the causes. • Replace the outdoor power circuit board. • Replace the indoor power board.



Symptoms: Nothing is displayed on the remote controller. ③	LED display of the indoor controller board LED1 : ● LED2 : ● or ● LED3 : —
---	---

Diagnosis flow	Cause	Inspection method and troubleshooting
<p>Check the voltage of the terminal block (TB6) of the remote controller.</p> <p>10 to 16 V DC?</p> <p>YES</p> <p>NO</p> <p>Check the status of the LED2.</p> <p>Lighting</p> <p>Blinking</p> <p>Check the status of the LED2 after disconnecting the remote controller wire from the indoor unit.</p> <p>Lighting</p> <p>Blinking</p>	<ul style="list-style-type: none"> Defective remote controller Breaking or poor contact of the remote controller wire The remote controller wire short-circuits Defective indoor controller board 	<ul style="list-style-type: none"> Replace the remote controller. Check if there is breaking or poor contact of the remote controller wire. Check the voltage of the remote controller wire. If it is not between 10 and 16 V DC, the indoor controller board must be defective. Check if the remote controller wire is short-circuited. Replace the indoor controller board.

9-4. HOW TO CHECK THE PARTS

PUHZ-SHW80VAA.UK
 PUHZ-SHW80VAA-BS.UK
 PUHZ-SHW80YAA.UK
 PUHZ-SHW80YAA-BS.UK
 PUHZ-SW75VAA.UK
 PUHZ-SW75VAA-BS.UK
 PUHZ-SW75YAA.UK
 PUHZ-SW75YAA-BS.UK
 PUHZ-SW75VAA-SC.UK
 PUHZ-SW75YAA-SC.UK

PUHZ-SHW112VAA.UK
 PUHZ-SHW112VAA-BS.UK
 PUHZ-SHW112YAA.UK
 PUHZ-SHW112YAA-BS.UK
 PUHZ-SW100VAA.UK
 PUHZ-SW100VAA-BS.UK
 PUHZ-SW100YAA.UK
 PUHZ-SW100YAA-BS.UK

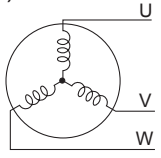
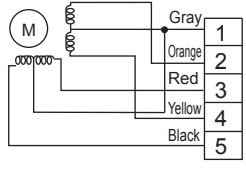
Parts name	Check points														
Thermistor (TH3) <Liquid> Thermistor (TH4) <Discharge> Thermistor (TH6) <2-phase pipe> Thermistor (TH7) <Ambient> Thermistor (TH8) <Heat sink> Thermistor (TH32) <Suction>*1 Thermistor (TH33) <Comp. surface>	Disconnect the connector then measure the resistance with a tester. (At the ambient temperature 10 to 30°C) <table border="1" style="margin-left: 20px;"> <thead> <tr> <th></th> <th>Normal</th> <th>Abnormal</th> </tr> </thead> <tbody> <tr> <td>TH4</td> <td>160 to 410 kΩ</td> <td rowspan="5">Open or short</td> </tr> <tr> <td>TH3</td> <td rowspan="4">4.3 to 9.6 kΩ</td> </tr> <tr> <td>TH6</td> </tr> <tr> <td>TH7</td> </tr> <tr> <td>TH32</td> </tr> <tr> <td>TH33</td> <td rowspan="2">39 to 105 kΩ</td> </tr> <tr> <td>TH8</td> </tr> </tbody> </table>		Normal	Abnormal	TH4	160 to 410 kΩ	Open or short	TH3	4.3 to 9.6 kΩ	TH6	TH7	TH32	TH33	39 to 105 kΩ	TH8
	Normal	Abnormal													
TH4	160 to 410 kΩ	Open or short													
TH3	4.3 to 9.6 kΩ														
TH6															
TH7															
TH32															
TH33	39 to 105 kΩ														
TH8															
Fan motor (MF1)	Refer to the next page.														
Solenoid valve coil <4-way valve> (21S4)	Measure the resistance between the terminals with a tester. (At the ambient temperature 20°C) <table border="1" style="margin-left: 20px;"> <thead> <tr> <th>Normal</th> <th>Abnormal</th> </tr> </thead> <tbody> <tr> <td>1435 ± 150 Ω</td> <td>Open or short</td> </tr> </tbody> </table>	Normal	Abnormal	1435 ± 150 Ω	Open or short										
Normal	Abnormal														
1435 ± 150 Ω	Open or short														
Motor for compressor (MC) 	Measure the resistance between the terminals with a tester. (Winding temperature 20°C) <table border="1" style="margin-left: 20px;"> <thead> <tr> <th>SHW80VAA SHW112VAA SW100VAA</th> <th>SHW80YAA SHW112YAA SW100YAA</th> <th>SW75VAA</th> <th>SW75YAA</th> <th>Abnormal</th> </tr> </thead> <tbody> <tr> <td>0.74</td> <td>0.94</td> <td>0.95</td> <td>1.65</td> <td>Open or short</td> </tr> </tbody> </table>	SHW80VAA SHW112VAA SW100VAA	SHW80YAA SHW112YAA SW100YAA	SW75VAA	SW75YAA	Abnormal	0.74	0.94	0.95	1.65	Open or short				
SHW80VAA SHW112VAA SW100VAA	SHW80YAA SHW112YAA SW100YAA	SW75VAA	SW75YAA	Abnormal											
0.74	0.94	0.95	1.65	Open or short											
Linear expansion valve (LEV-A/LEV-B/LEV-C*1) 	Disconnect the connector then measure the resistance with a tester. (Winding temperature 20°C) <table border="1" style="margin-left: 20px;"> <thead> <tr> <th colspan="4">Normal</th> <th>Abnormal</th> </tr> </thead> <tbody> <tr> <td>Gray - Black</td> <td>Gray - Red</td> <td>Gray - Yellow</td> <td>Gray - Orange</td> <td rowspan="2">Open or short</td> </tr> <tr> <td colspan="4" style="text-align: center;">46 ± 3Ω</td> </tr> </tbody> </table>	Normal				Abnormal	Gray - Black	Gray - Red	Gray - Yellow	Gray - Orange	Open or short	46 ± 3Ω			
Normal				Abnormal											
Gray - Black	Gray - Red	Gray - Yellow	Gray - Orange	Open or short											
46 ± 3Ω															

*1 PUHZ-SHW only.

Check method of DC fan motor (fan motor/outdoor controller circuit board)

① Notes

- High voltage is applied to the connector (CNF1) for the fan motor. Pay attention to the service.
- Do not pull out the connector (CNF1) for the motor with the power supply on.
(It causes trouble of the outdoor controller circuit board and fan motor.)

② Self check

Symptom: The outdoor fan cannot rotate.

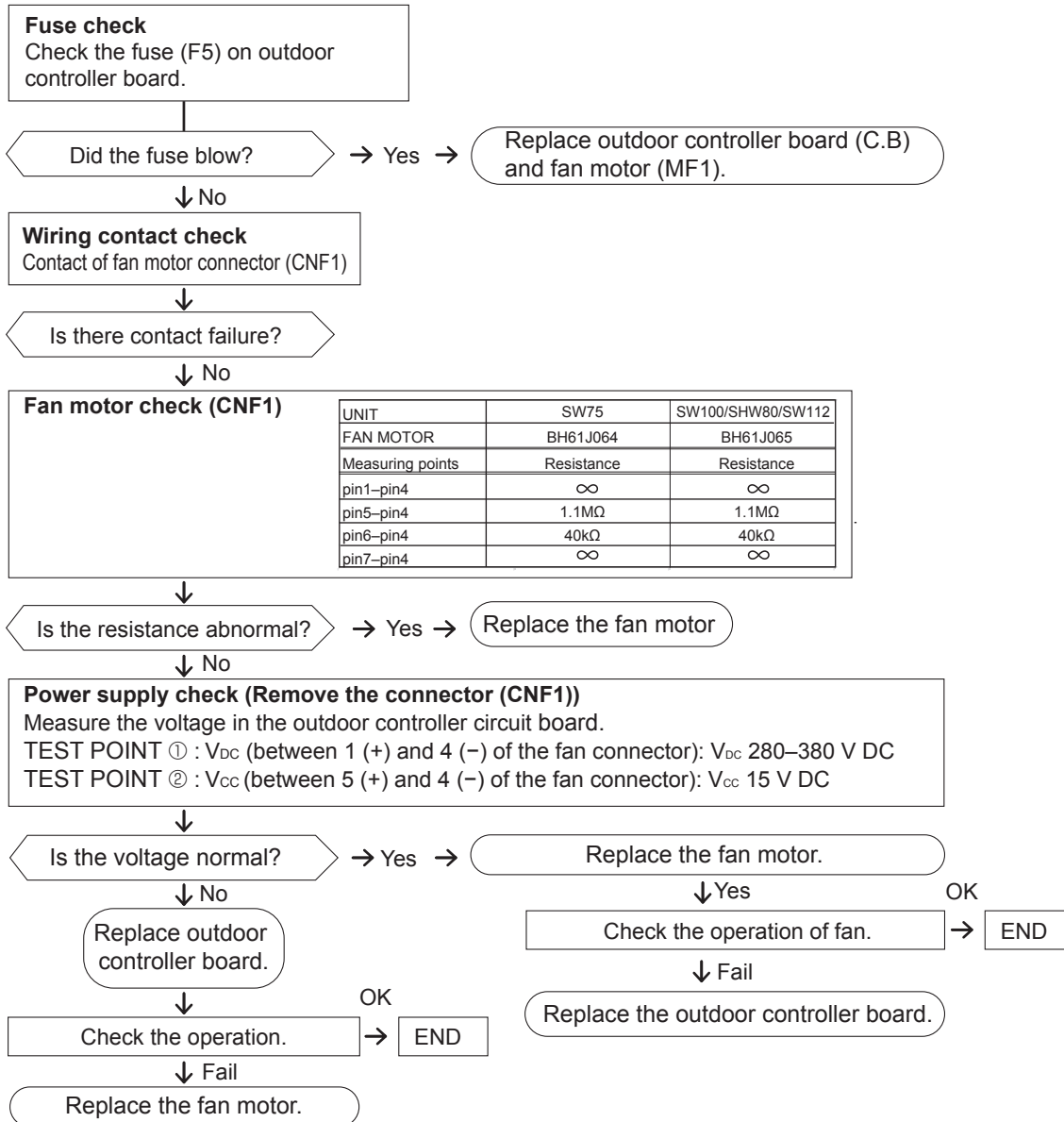

9-5. HOW TO CHECK THE COMPONENTS

<HIGH PRESSURE SENSOR>

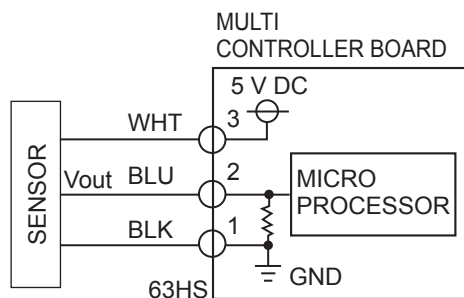
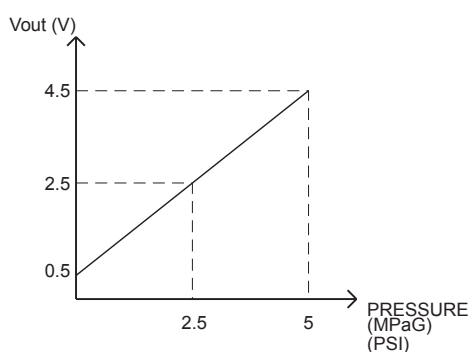

- ③-① : 5 V (DC)
- ②-① : Output V_{out} (DC)

<Thermistor feature chart>

Low temperature thermistors

- Thermistor <Liquid> (TH3)
- Thermistor <2-phase pipe> (TH6)
- Thermistor <Ambient> (TH7)
- Thermistor <Suction> (TH32) (PUHZ-SHW only)

Thermistor R0 = 15 kΩ ± 3 %
 B constant = 3480 ± 2 %

$$R_t = 15 \exp\left\{3480 \left(\frac{1}{273+t} - \frac{1}{273} \right)\right\}$$

0 °C	15 kΩ	30 °C	4.3 kΩ
10 °C	9.6 kΩ	40 °C	3.0 kΩ
20 °C	6.3 kΩ		
25 °C	5.2 kΩ		

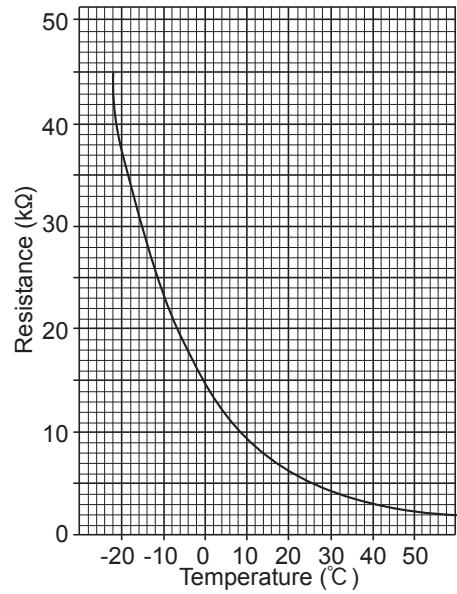

Medium temperature thermistor

- Thermistor <Heat sink> (TH8)

Thermistor R50 = 17 kΩ ± 2 %
 B constant = 4150 ± 3 %

$$R_t = 17 \exp\left\{4150 \left(\frac{1}{273+t} - \frac{1}{323} \right)\right\}$$

0 °C	180 kΩ
25 °C	50 kΩ
50 °C	17 kΩ
70 °C	8 kΩ
90 °C	4 kΩ

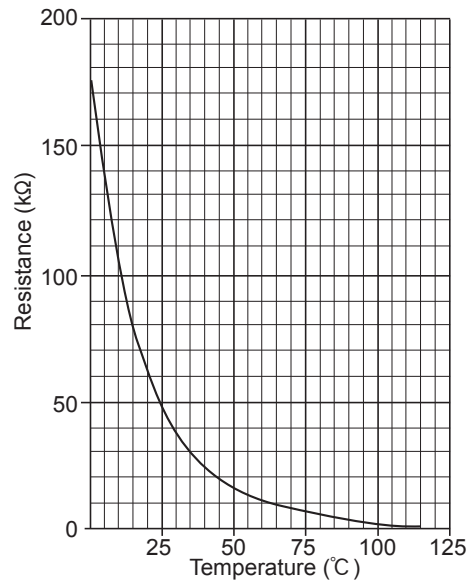

High temperature thermistor

- Thermistor <Discharge> (TH4)
- Thermistor <Comp. surface> (TH33)

Thermistor R120 = 7.465 kΩ ± 2 %
 B constant = 4057 ± 2 %

$$R_t = 7.465 \exp\left\{4057 \left(\frac{1}{273+t} - \frac{1}{393} \right)\right\}$$

20 °C	250 kΩ	70 °C	34 kΩ
30 °C	160 kΩ	80 °C	24 kΩ
40 °C	104 kΩ	90 °C	17.5 kΩ
50 °C	70 kΩ	100 °C	13.0 kΩ
60 °C	48 kΩ	110 °C	9.8 kΩ

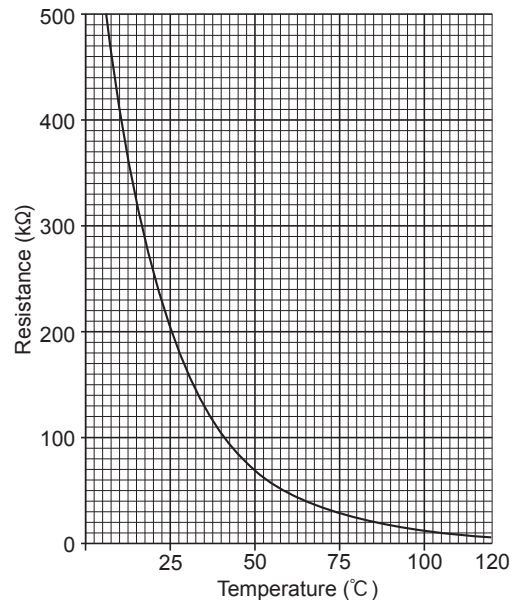

Linear expansion valve

(1) Operation summary of the linear expansion valve

- Linear expansion valve opens/closes through stepping motor after receiving the pulse signal from the outdoor controller board.
 - Valve position can be changed in proportion to the number of pulse signal.
- <Connection between the outdoor controller board and the linear expansion valve>

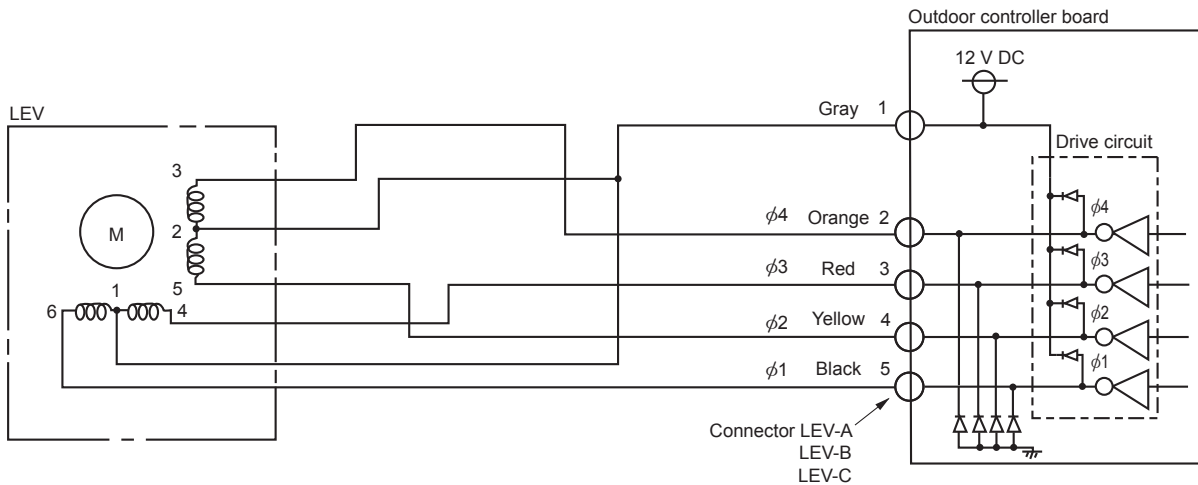

<Output pulse signal and the valve operation>

Output (Phase)	Output							
	1	2	3	4	5	6	7	8
$\phi 1$	ON	ON	OFF	OFF	OFF	OFF	OFF	ON
$\phi 2$	OFF	ON	ON	ON	OFF	OFF	OFF	OFF
$\phi 3$	OFF	OFF	OFF	ON	ON	ON	OFF	OFF
$\phi 4$	OFF	OFF	OFF	OFF	OFF	ON	ON	ON

Opening a valve : 8 → 7 → 6 → 5 → 4 → 3 → 2 → 1 → 8

Closing a valve : 1 → 2 → 3 → 4 → 5 → 6 → 7 → 8 → 1

The output pulse shifts in above order.

- When linear expansion valve operation stops, all output phases become OFF.
- When the power is turned on, 700 pulse closing valve signal will be sent till it goes to ㉓ point in order to define the valve position. (The pulse signal is being sent for about 20 seconds.)

(2) Linear expansion valve operation

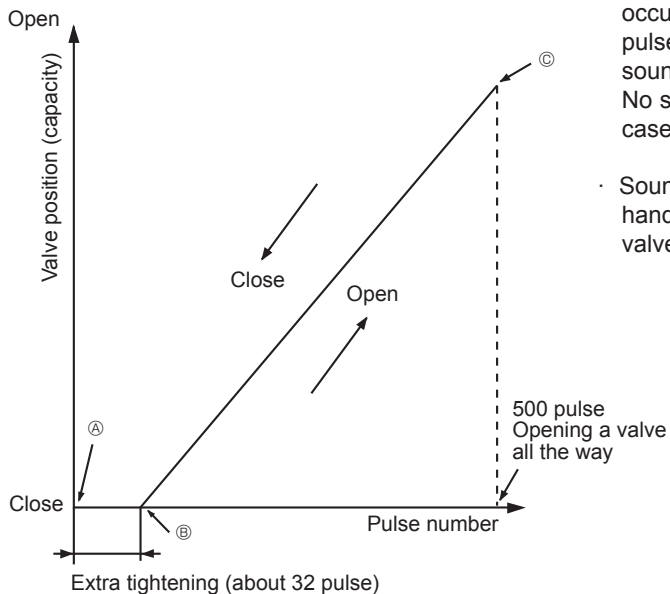

When the valve moves smoothly, there is no sound or vibration occurring from the linear expansion valve : however, when the pulse number moves from ㉔ to ㉓ or when the valve is locked, sound can be heard.

No sound is heard when the pulse number moves from ㉔ to ㉓ in case coil is burnt out or motor is locked by open-phase.

- Sound can be detected by placing the ear against the screw driver handle while putting the screw driver to the linear expansion valve.

(3) How to attach and detach the coil of linear expansion valve

<Composition>

Linear expansion valve is separable into the main body and the coil as shown in the diagram below.

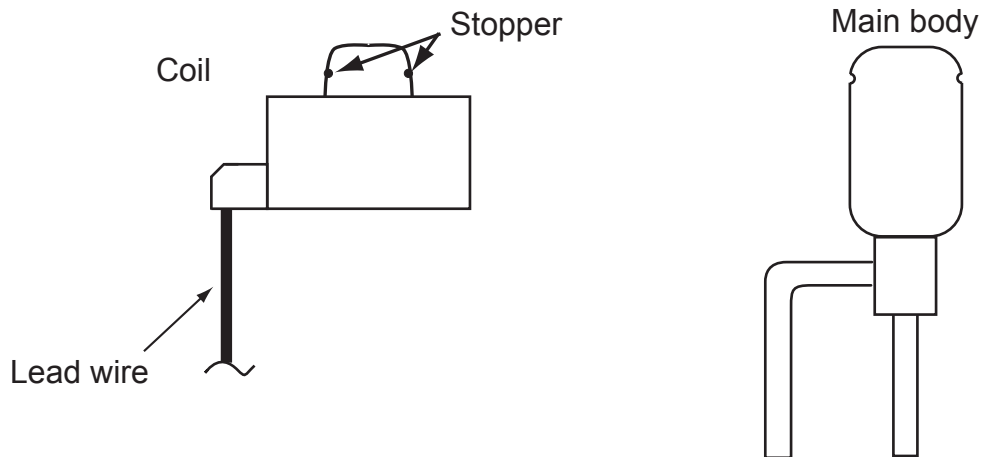

<How to detach the coil>

Hold the lower part of the main body (shown as A) firmly so that the main body does not move and detach the coil by pulling it upward.

Be sure to detach the coil holding main body firmly. Otherwise pipes can bend due to stress.

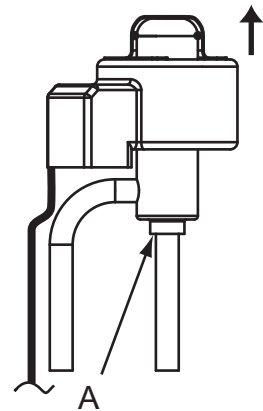

<How to attach the coil>

Hold the lower part of the main body (shown as A) firmly so that the main body does not move and attach the coil by inserting it downward into the main body. Then securely attach the coil stopper to main body. (At this time, be careful that stress is not added to lead wire and main body is not wound by lead wire.)

If the stopper is not firmly attached to main body, coil may be detached from the main body and that can cause defective operation of linear expansion valve.

To prevent piping stress, be sure to attach the coil holding the main body of linear expansion valve firmly. Otherwise pipe may break.

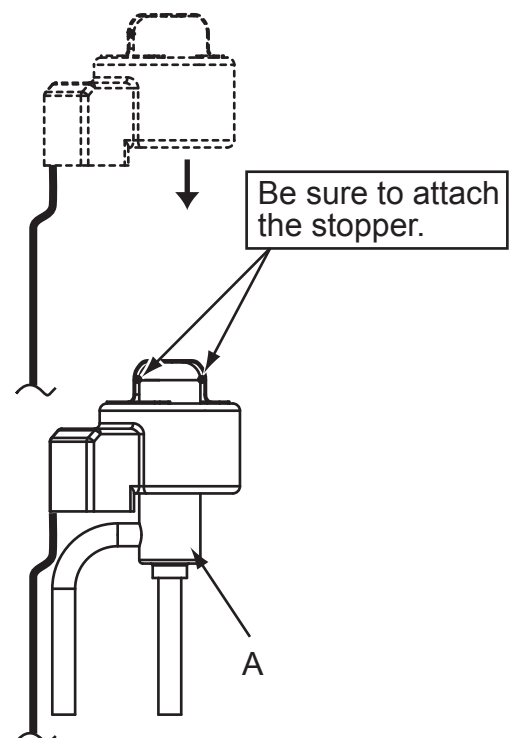

9-6. TEST POINT DIAGRAM

Outdoor controller circuit board

PUHZ-SHW80VAA.UK

PUHZ-SHW112VAA.UK

PUHZ-SHW80YAA.UK

PUHZ-SHW112YAA.UK

PUHZ-SHW80VAA-BS.UK

PUHZ-SHW112VAA-BS.UK

PUHZ-SHW80YAA-BS.UK

PUHZ-SHW112YAA-BS.UK

PUHZ-SW75VAA.UK

PUHZ-SW100VAA.UK

PUHZ-SW75YAA.UK

PUHZ-SW100YAA.UK

PUHZ-SW75VAA-BS.UK

PUHZ-SW100VAA-BS.UK

PUHZ-SW75YAA-BS.UK

PUHZ-SW100YAA-BS.UK

PUHZ-SW75VAA-SC.UK

PUHZ-SW75YAA-SC.UK

<CAUTION> TEST POINT① is high voltage.

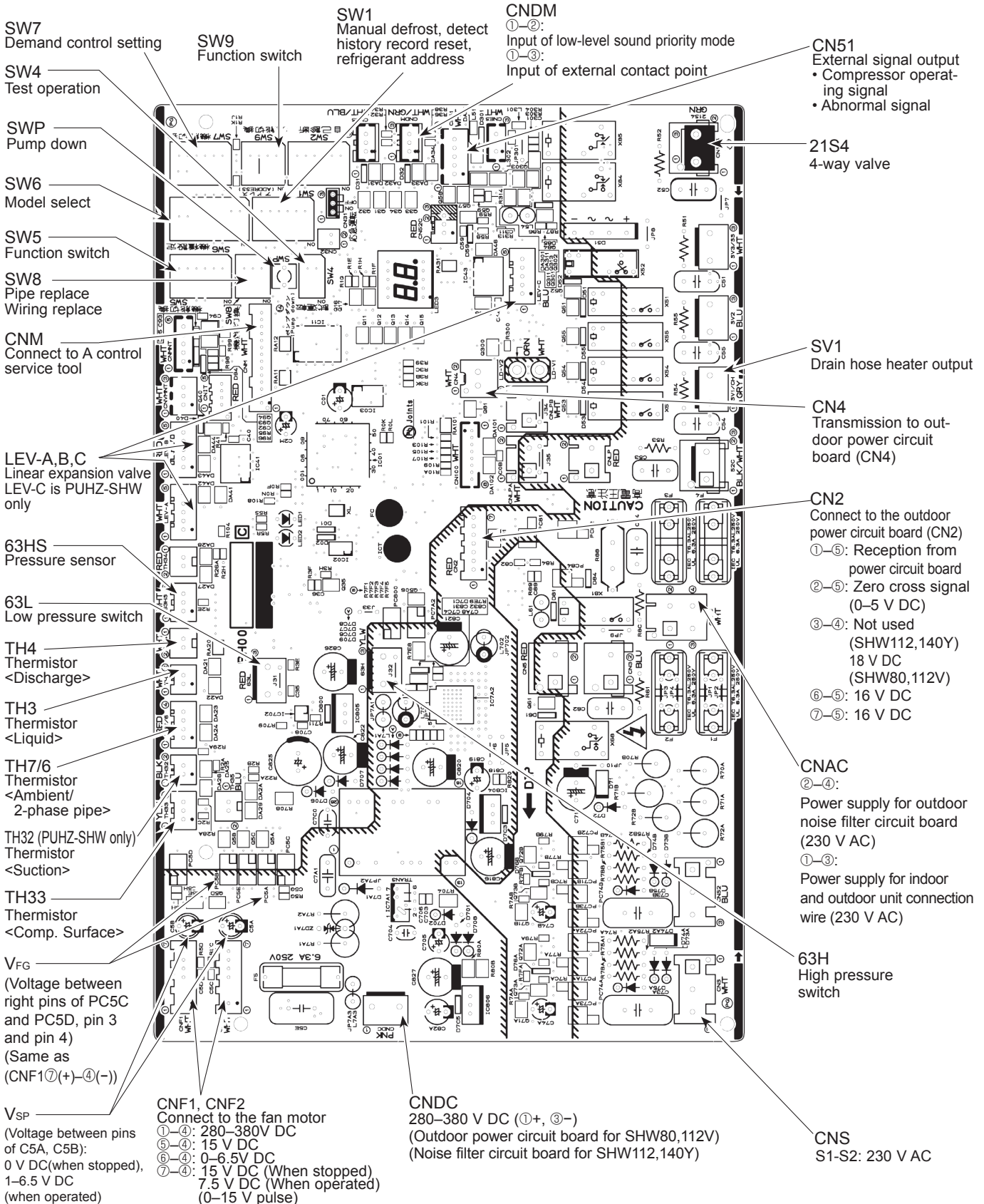

Outdoor noise filter circuit board

PUHZ-SHW80YAA.UK
PUHZ-SHW80YAA-BS.UK
PUHZ-SW75YAA.UK
PUHZ-SW75YAA-BS.UK
PUHZ-SW75YAA-SC.UK

PUHZ-SHW112YAA.UK
PUHZ-SHW112YAA-BS.UK
PUHZ-SW100YAA.UK
PUHZ-SW100YAA-BS.UK

LO1, LO2, LO3
POWER SUPPLY
 LO1-LO2/LO2-LO3/LO3-LO1 : AC400V OUTPUT
 (Connect to the outdoor converter circuit board (L1-IN), ACL2, ACL3)

CNAC2
230 V AC
 (Connect to the outdoor controller circuit board (CNAC))

CNCT
 Primary current
 (Connect to the outdoor power circuit board (CN5))

NO
 Connect to the outdoor converter circuit board (N-IN)

CNL
 Connect to the ACL4

CNDC
 (Connect to the outdoor controller circuit board (CNDC))

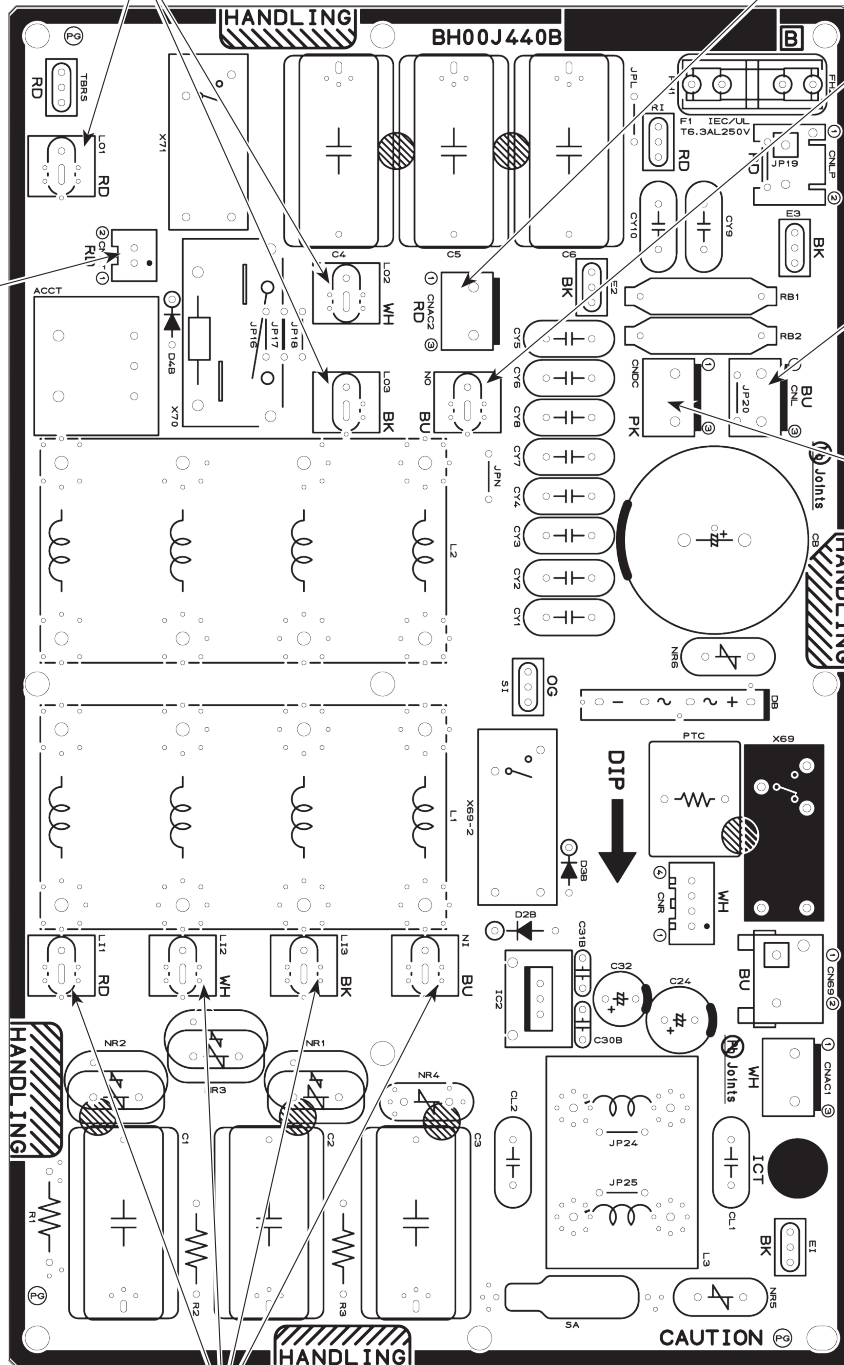

LI1, LI2, LI3, NI
POWER SUPPLY
 LI1-LI2/LI-LI3/LI3-LI1 : 400 V AC input
 LI1-NI/LI2-NI/LI3-NI : 230 V AC input
 (Connect to the terminal block (TB1))

Outdoor power circuit board
PUHZ-SHW80VAA.UK
PUHZ-SHW112VAA.UK
PUHZ-SW75VAA.UK
PUHZ-SW100VAA.UK
PUHZ-SHW80VAA-BS.UK
PUHZ-SHW112VAA-BS.UK
PUHZ-SW75VAA-BS.UK
PUHZ-SW100VAA-BS.UK
PUHZ-SW75VAA-SC.UK

Brief Check of DIP-IPM and DIODE MODULE

Usually, they are in a state of being short-circuited if they are broken. Measure the resistance in the following points (connectors, etc.). If they are short-circuited, it means that they are broken.

1. Check of DIP-IPM

P2 - U2, P2 - V2, P2 - W2, N2 - U2, N2 - V2, N2 - W2
 P3 - U3, P3 - V3, P3 - W3, N3 - U3, N3 - V3, N3 - W3

2. Check of DIODE MODULE

P1 - L, P1 - N, L - N1, N - N1

Note: The marks, L, N, N1, N2, N3, P1, P2, P3, U2, U3, V2, V3, W2, and W3 shown in the diagram are not actually printed on the board.

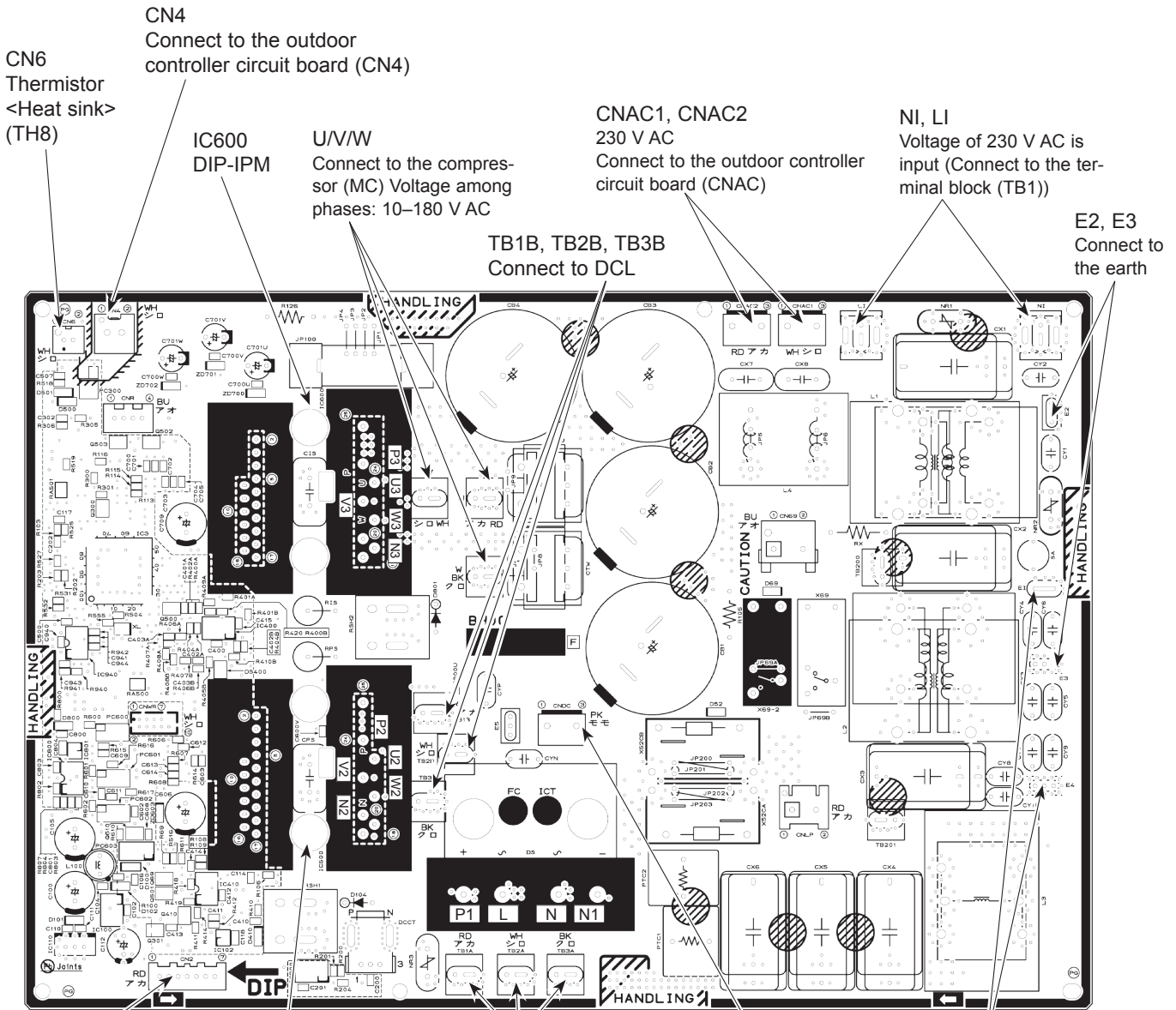

CN2
 Connect to the outdoor controller circuit board (CN2)
 ①-⑤: Transmitting signal to outdoor controller circuit board (0-5 V DC)
 ②-⑤: Zero cross signal (0-5 V DC)
 ③-④: 18 V DC
 ⑥-⑤: 16 V DC
 ⑦-⑤: 16 V DC

Outdoor power circuit board
PUHZ-SHW80YAA.UK
PUHZ-SHW112YAA.UK
PUHZ-SW75YAA.UK
PUHZ-SW100YAA.UK
PUHZ-SHW80YAA-BS.UK
PUHZ-SHW112YAA-BS.UK
PUHZ-SW75YAA-BS.UK
PUHZ-SW100YAA-BS.UK
PUHZ-SW75YAA-SC.UK

Brief Check of POWER MODULE

• Usually, they are in a state of being short-circuited if they are broken. Measure the resistance in the following points (connectors, etc.). If they are short-circuited, it means that they are broken.

1. Check of DIODE MODULE

L1 - P1, L2 - P1, L3 - P1, L1 - N1, L2 - N1, L3 - N1

2. Check of DIP-IPM

P2 - U, P2 - V, P2 - W, N2 - U, N2 - V, N2 - W

Note: The marks L1, L2, L3, N1, N2, P1, P2, U, V and W shown in the diagram are not actually printed on the board.

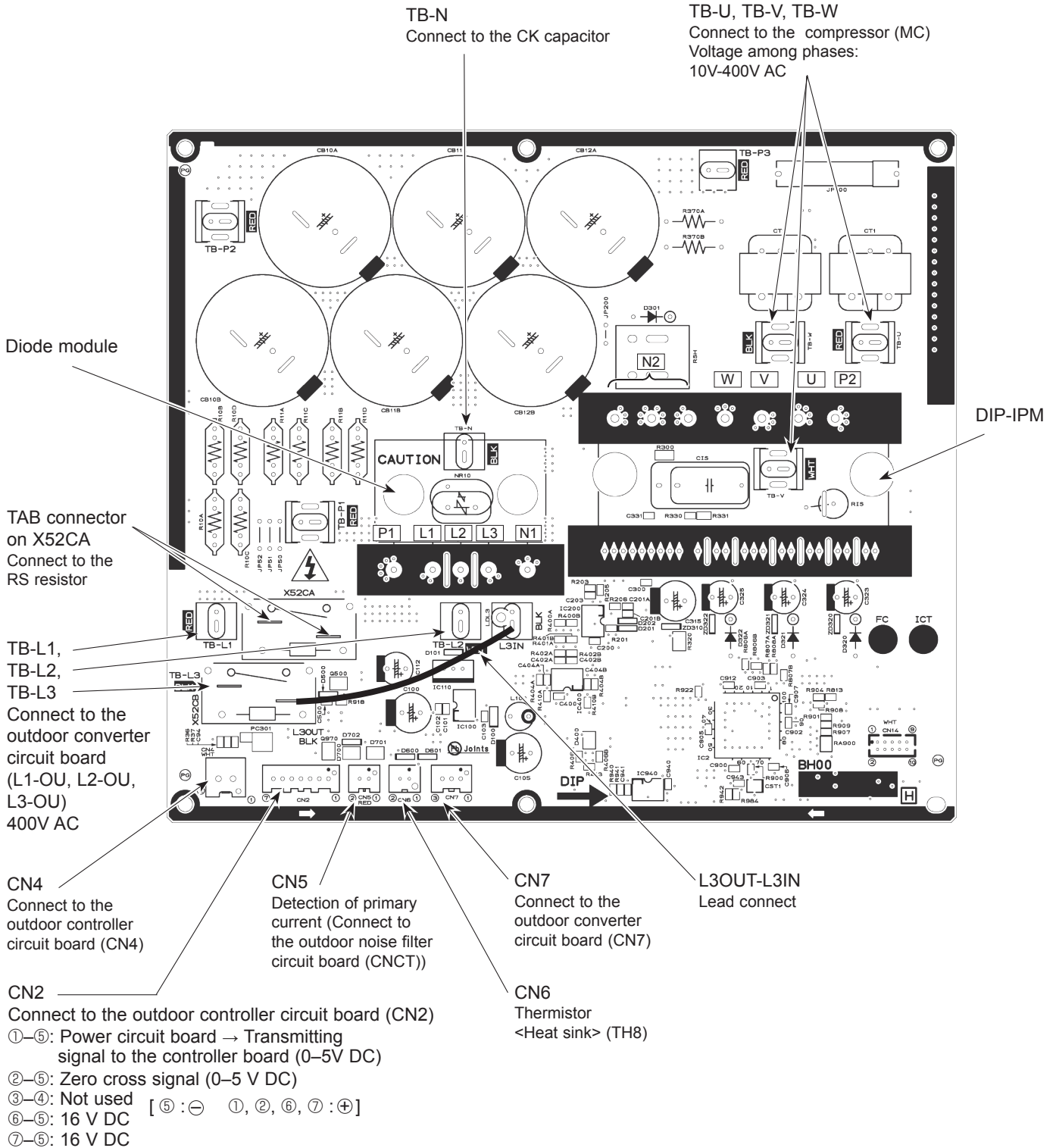

Outdoor converter circuit board

**PUHZ-SHW80YAA.UK
 PUHZ-SHW80YAA-BS.UK
 PUHZ-SW75YAA.UK
 PUHZ-SW75YAA-BS.UK
 PUHZ-SW75YAA-SC.UK**

**PUHZ-SHW112YAA.UK
 PUHZ-SHW112YAA-BS.UK
 PUHZ-SW100YAA.UK
 PUHZ-SW100YAA-BS.UK**

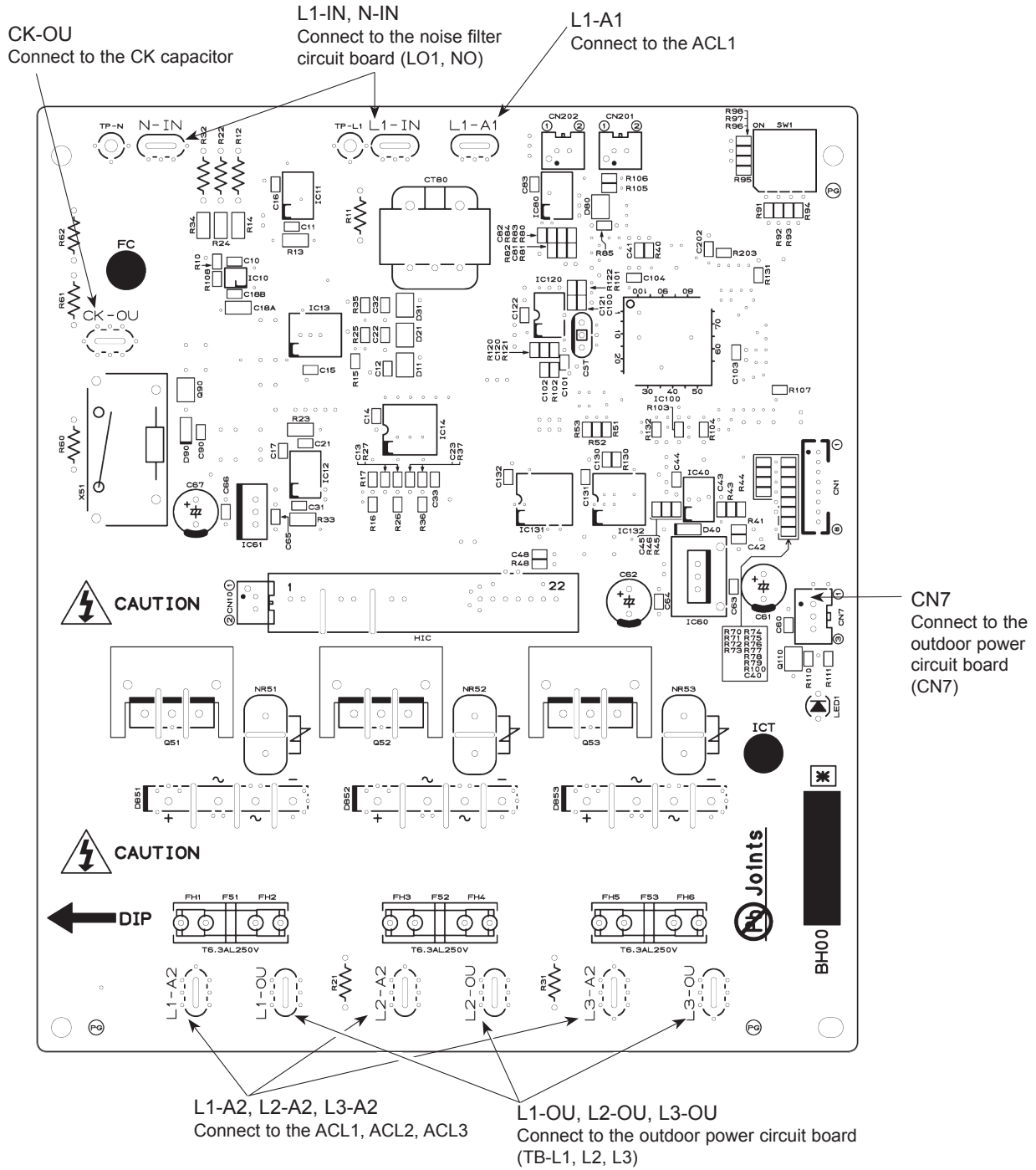

9-7. FUNCTION OF SWITCHES, CONNECTORS AND JUMPERS

(1) Function of switches

PUHZ-SHW80VAA.UK
 PUHZ-SHW80VAA-BS.UK
 PUHZ-SHW80YAA.UK
 PUHZ-SHW80YAA-BS.UK
 PUHZ-SW75VAA.UK
 PUHZ-SW75VAA-BS.UK
 PUHZ-SW75YAA.UK
 PUHZ-SW75YAA-BS.UK
 PUHZ-SW75VAA-SC.UK

PUHZ-SHW112VAA.UK
 PUHZ-SHW112VAA-BS.UK
 PUHZ-SHW112YAA.UK
 PUHZ-SHW112YAA-BS.UK
 PUHZ-SW100VAA.UK
 PUHZ-SW100VAA-BS.UK
 PUHZ-SW100YAA.UK
 PUHZ-SW100YAA-BS.UK
 PUHZ-SW75YAA-SC.UK

Type of switch	Switch No.	Function	Action by the switch operation		Effective timing		
			ON	OFF			
DIP switch	SW1	1	Manual defrost *1	Start	Normal	When compressor is working in heating operation.*1	
		2	Abnormal history clear	Clear	Normal	off or operating	
		3	Refrigerant address setting				When power supply ON
		4					
		5					
		6					
	6						
	SW4	1	No function	—	—	—	
		2	No function	—	—	—	
	SW8	1	Use of existing pipe	Used	Not used	Always	
		2	No function	—	—	—	
		3	Separate indoor/outdoor unit power supplies	Used	Not used	When power supply ON	
Push switch	SWP	Pump down	Start	Normal	Under suspension		

*1 Manual defrost should be done as follows.

- ① Change the DIP SW1-1 on the outdoor controller board from OFF to ON.
- ② Manual defrost will start by the above operation ① if all these conditions written below are satisfied.
 - Heat mode setting
 - 10 minutes have passed since compressor started operating or previous manual defrost finished.
 - Pipe temperature is less than or equal to 8°C.

Manual defrost will finish if certain conditions are satisfied.

Manual defrost can be done if above conditions are satisfied when DIP SW1-1 is changed from OFF to ON.

After DIP SW1-1 is changed from OFF to ON, there is no problem if DIP SW1-1 is left ON or changed to OFF again. This depends on the service conditions.

The black square (■) indicates a switch position.

Type of Switch	Switch	No.	Function	Action by the switch operation		Effective timing	
				ON	OFF		
DIP switch	SW5	1	No function	—	—	—	
		2	Power failure automatic recovery*2	Auto recovery	No auto recovery	When power supply ON	
		3,4,5,6	No function	—	—	—	
	SW7*3	1,2,3	No function	—	—	—	
		4	No function	—	—	—	
		5	No function	—	—	—	
	SW9	6	Defrost setting	For high humidity	Normal	Always	
		1	No function	—	—	—	
	SW9	2	Function switch	Valid	Normal	Always	
		3,4	Starting Ambient temp. of flash injection	(PUHZ-SHW only)			Always
				SW9-3	SW9-4	Ambient temp.	
				OFF	OFF	≤ 3°C (Initial setting)	
				OFF	ON	≤ 0°C	
	ON	OFF	≤ -3°C				
	ON	ON	≤ -6°C				
	SW6	1	Model select				
		2					
3							
4							
5							
6							
7							
8							
SW5	6						

*2 “Power failure automatic recovery” can be set by either remote controller or this DIP SW. If one of them is set to ON, “Auto recovery” activates. Please set “Auto recovery” basically by remote controller because all units do not have DIP SW. Please refer to the indoor unit installation manual.

*3 Please do not use SW7-3, 4, 6 usually. Trouble might be caused by the usage condition.

(2) Function of connector

Types	Connector	Function	Action by open/short operation		Effective timing
			Short	Open	
Connector	CN31	Emergency operation	Start	Normal	When power supply ON

PUHZ-SHW80VAA.UK PUHZ-SHW112VAA.UK PUHZ-SHW80YAA.UK PUHZ-SHW112YAA.UK
 PUHZ-SHW80VAA-BS.UK PUHZ-SHW112VAA-BS.UK PUHZ-SHW80YAA-BS.UK PUHZ-SHW112YAA-BS.UK
 PUHZ-SW75VAA.UK PUHZ-SW100VAA.UK PUHZ-SW75YAA.UK PUHZ-SW100YAA.UK
 PUHZ-SW75VAA-BS.UK PUHZ-SW100VAA-BS.UK PUHZ-SW75YAA-BS.UK PUHZ-SW100YAA-BS.UK
 PUHZ-SW75VAA-SC.UK PUHZ-SW75YAA-SC.UK

<Display function of inspection for outdoor unit>

The blinking patterns of both LED1 (green) and LED2 (red) indicate the types of abnormality when it occurs. Types of abnormality can be indicated in details by connecting an optional part "A-Control Service Tool (PAC-SK52ST)" to connector CNM on outdoor controller board.

[Display]

(1)Normal condition

Unit condition	Outdoor controller board		A-Control Service Tool	
	LED1 (Green)	LED2 (Red)	Check code	Indication of the display
When the power is turned on	Lighted	Lighted	— ↔ —	Alternately blinking display
When unit stops	Lighted	Not lighted	00, etc.	Operation mode
When compressor is warming up	Lighted	Not lighted	08, etc.	
When unit operates	Lighted	Lighted	C5, H7, etc.	

(2)Abnormal condition

Indication		Contents	Check code*	Error	Inspection method	Detailed reference page	
Outdoor controller board							
LED1 (Green)	LED2 (Red)						
1 blinking	2 blinking	Connector(63L) is open.	F3	①Check if connector (63H or 63L) on the outdoor controller board is not disconnected. ②Check continuity of pressure switch (63H or 63L) by tester.		P.22	
		Connector(63H) is open.	F5			P.22	
		2 connectors are open.	F9			P.23	
2 blinking	1 blinking	Miswiring of indoor/outdoor unit connecting wire, excessive number of indoor units (4 units or more)	—	①Check if indoor/outdoor connecting wire is connected correctly. ②Check if 4 or more indoor units are connected to outdoor unit. ③Check if noise entered into indoor/outdoor connecting wire or power supply. ④Re-check error by turning off power, and on again.		P.23 (EA)	
		Miswiring of indoor/outdoor unit connecting wire (converse wiring or disconnection)	—			P.23 (Eb)	
		Startup time over	—			P.23 (EC)	
	2 blinking		Indoor/outdoor unit communication error (signal receiving error) is detected by indoor unit.	E6	①Check if indoor/outdoor connecting wire is connected correctly. ②Check if noise entered into indoor/outdoor connecting wire or power supply. ③Check if noise entered into indoor/outdoor controller board. ④Re-check error by turning off power, and on again.		**
			Indoor/outdoor unit communication error (transmitting error) is detected by indoor unit.	E7			**
			Indoor/outdoor unit communication error (signal receiving error) is detected by outdoor unit.	—			P.29 (E8)
			Indoor/outdoor unit communication error (transmitting error) is detected by outdoor unit.	—			P.29 (E9)
	3 blinking		Remote controller signal receiving error is detected by remote controller.	E0	①Check if connecting wire of indoor unit or remote controller is connected correctly. ②Check if noise entered into transmission wire of remote controller. ③Re-check error by turning off power, and on again.		P.28
			Remote controller transmitting error is detected by remote controller.	E3			P.29
			Remote controller signal receiving error is detected by indoor unit.	E4			P.28
			Remote controller transmitting error is detected by indoor unit.	E5			P.29
	4 blinking		Check code is not defined.	EF	①Check if noise entered into transmission wire of remote controller. ②Check if noise entered into indoor/outdoor connecting wire. ③Re-check error by turning off power, and on again.		P.29
Incorrect connection			EE	①Connect I/F or FTC to the unit.			P.23
5 blinking		Serial communication error <Communication between outdoor controller board and outdoor power board>	Ed	①Check if connector (CN4) on outdoor controller board and outdoor power board is not disconnected.		P.29	

* Check code displayed on remote controller

** Refer to service manual for indoor unit.

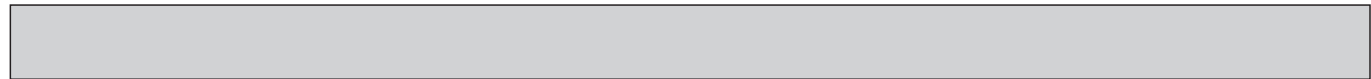

Indication		Error			
Outdoor controller board		Contents	Check code*	Inspection method	Detailed reference page
LED1 (Green)	LED2 (Red)				
3 blinking	1 blinking	Abnormality of discharging temperature (TH4) and Comp. surface temperature (TH33)	U2	①Check if stop valves are open. ②Check if connectors (TH4, LEV-A, and LEV-B) on outdoor controller board are not disconnected. ③Check if unit is filled with specified amount of refrigerant. ④Measure resistance values among terminals on indoor valve and outdoor linear expansion valve using a tester.	P.24
		Abnormality of superheat due to low discharge temperature	U7		P.25
	2 blinking	Abnormal high pressure (High pressure switch 63H operated.)	U1	①Check if indoor/outdoor units have a short cycle on their air ducts. ②Check if connector(63H)(63L) on outdoor controller board is not disconnected. ③Check if heat exchanger and filter is not dirty. ④Measure resistance values among terminals on linear expansion valve using a tester.	P.24
		Abnormal low pressure (Low pressure switch 63L operated.)	UL		P.27
	3 blinking	Abnormality of outdoor fan motor rotational speed	U8	①Check the outdoor fan motor. ②Check if connector (TH3) (63HS) on outdoor controller board is disconnected.	P.25
		Protection from overheat operation (TH3)	Ud		P.27
	4 blinking	Compressor overcurrent breaking(Start-up locked)	UF	①Check if stop valves are open. ②Check looseness, disconnection, and converse connection of compressor wiring. ③Measure resistance values among terminals on compressor using a tester. ④Check if outdoor unit has a short cycle on its air duct. ⑤Check leakage of refrigerant.	P.27
			UP		P.28
			UH		P.27
			U6		P.25
	5 blinking	Open/short of outdoor thermistors (TH4, TH33)	U3	①Check if connectors (TH3, TH32, TH4, TH33 and TH7/6) on outdoor controller board and connector (CN3) on outdoor power board are not disconnected. ②Measure resistance value of outdoor thermistors.	P.24
			U4		P.25
	6 blinking	Abnormality of heat sink temperature	U5	①Check if indoor/outdoor units have a short cycle on their air ducts. ②Measure resistance value of outdoor thermistor(TH8).	P.25
	7 blinking	Abnormality of voltage	U9	①Check looseness, disconnection, and converse connection of compressor wiring. ②Measure resistance value among terminals on compressor using a tester. ③Check if power supply voltage decreases. ④Check the wiring of CN52C. ⑤Check the wiring of CNAF.	P.26– P.27
4 blinking	1 blinking	Abnormality of room temperature thermistor (TH1)	P1	①Check if connectors on indoor controller board are not disconnected. ②Measure resistance value of indoor thermistors.	**
		Abnormality of pipe temperature thermistor /Liquid (TH2)	P2		**
		Abnormality of tank temperature thermistor	P9		**
	4 blinking	Abnormality of pipe temperature	P8	①Check if indoor thermistors(TH2 and TH5) are not disconnected from holder. ②Check if stop valve is open. ③Check converse connection of extension pipe. (on plural units connection) ④Check if indoor/outdoor connecting wire is connected correctly. (on plural units connection)	P.30

* Check code displayed on remote controller

** Refer to service manual for indoor unit.

<Outdoor unit operation monitor function>

[When optional part "A-Control Service Tool (PAC-SK52ST)" is connected to outdoor controller board (CNM)]

Digital indicator LED1 displays 2 digit number or code to inform operation condition and the meaning of error code by controlling DIP SW2 on "A-Control Service Tool".

Operation indicator SW2 : Indicator change of self diagnosis

The black square (■) indicates a switch position.

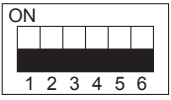
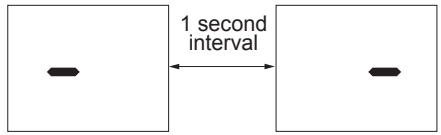
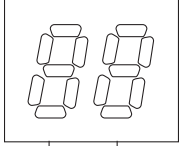
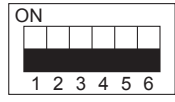
SW2 setting	Display detail	Explanation for display	Unit																																																																	
	<p><Digital indicator LED1 working details> (Be sure that 1 to 6 in the SW2 are set to OFF.)</p> <p>(1) Display when the power supply ON When the power supply ON, blinking displays by turns. Wait for 4 minutes at the longest.</p> <p>(2) When the display lights (Normal operation)</p> <p>① Operation mode display.</p>																																																																			
	<p>LED1 (Lighting)</p> 	<p>SW2 (Initial setting)</p> 																																																																		
	<p>The tens digit : Operation mode</p> <table border="1"> <thead> <tr> <th>Display</th> <th>Operation Model</th> </tr> </thead> <tbody> <tr> <td>O</td> <td>OFF / FAN</td> </tr> <tr> <td>C</td> <td>COOLING / DRY *</td> </tr> <tr> <td>H</td> <td>HEATING</td> </tr> <tr> <td>d</td> <td>DEFROSTING</td> </tr> </tbody> </table>	Display	Operation Model	O	OFF / FAN	C	COOLING / DRY *	H	HEATING	d	DEFROSTING	<p>The ones digit : Relay output</p> <table border="1"> <thead> <tr> <th>Display</th> <th>Warming-up Compressor</th> <th>Compressor</th> <th>4-way valve</th> <th>Solenoid valve</th> </tr> </thead> <tbody> <tr> <td>0</td> <td>—</td> <td>—</td> <td>—</td> <td>—</td> </tr> <tr> <td>1</td> <td>—</td> <td>—</td> <td>—</td> <td>ON</td> </tr> <tr> <td>2</td> <td>—</td> <td>—</td> <td>ON</td> <td>—</td> </tr> <tr> <td>3</td> <td>—</td> <td>—</td> <td>ON</td> <td>ON</td> </tr> <tr> <td>4</td> <td>—</td> <td>ON</td> <td>—</td> <td>—</td> </tr> <tr> <td>5</td> <td>—</td> <td>ON</td> <td>—</td> <td>ON</td> </tr> <tr> <td>6</td> <td>—</td> <td>ON</td> <td>ON</td> <td>—</td> </tr> <tr> <td>7</td> <td>—</td> <td>ON</td> <td>ON</td> <td>ON</td> </tr> <tr> <td>8</td> <td>ON</td> <td>—</td> <td>—</td> <td>—</td> </tr> <tr> <td>A</td> <td>ON</td> <td>—</td> <td>ON</td> <td>—</td> </tr> </tbody> </table>	Display	Warming-up Compressor	Compressor	4-way valve	Solenoid valve	0	—	—	—	—	1	—	—	—	ON	2	—	—	ON	—	3	—	—	ON	ON	4	—	ON	—	—	5	—	ON	—	ON	6	—	ON	ON	—	7	—	ON	ON	ON	8	ON	—	—	—	A	ON	—	ON	—	
Display	Operation Model																																																																			
O	OFF / FAN																																																																			
C	COOLING / DRY *																																																																			
H	HEATING																																																																			
d	DEFROSTING																																																																			
Display	Warming-up Compressor	Compressor	4-way valve	Solenoid valve																																																																
0	—	—	—	—																																																																
1	—	—	—	ON																																																																
2	—	—	ON	—																																																																
3	—	—	ON	ON																																																																
4	—	ON	—	—																																																																
5	—	ON	—	ON																																																																
6	—	ON	ON	—																																																																
7	—	ON	ON	ON																																																																
8	ON	—	—	—																																																																
A	ON	—	ON	—																																																																
	<p>* C5 is displayed during replacement operation.</p> <p>② Display during error postponement Postponement code is displayed when compressor stops due to the work of protection device. Postponement code is displayed while error is being postponed.</p>																																																																			
	<p>(3) When the display blinks Inspection code is displayed when compressor stops due to the work of protection devices.</p> <table border="1"> <thead> <tr> <th>Display</th> <th>Contents to be inspected (During operation)</th> </tr> </thead> <tbody> <tr> <td>U1</td> <td>Abnormal high pressure (63H operated)</td> </tr> <tr> <td>U2</td> <td>Abnormal high discharge temperature, high comp. surface temperature, shortage of refrigerant</td> </tr> <tr> <td>U3</td> <td>Open/short of outdoor unit thermistors (TH4, TH33)</td> </tr> <tr> <td>U4</td> <td>Open/short of outdoor unit thermistors (TH3, TH32, TH6, TH7 and TH8)</td> </tr> <tr> <td>U5</td> <td>Abnormal temperature of heat sink</td> </tr> <tr> <td>U6</td> <td>Abnormality of power module</td> </tr> <tr> <td>U7</td> <td>Abnormality of superheat due to low discharge temperature</td> </tr> <tr> <td>U8</td> <td>Abnormality in outdoor fan motor</td> </tr> <tr> <td>Ud</td> <td>Overheat protection</td> </tr> <tr> <td>UF</td> <td>Compressor overcurrent interruption (When Comp. locked)</td> </tr> <tr> <td>UH</td> <td>Current sensor error</td> </tr> <tr> <td>UL</td> <td>Abnormal low pressure (63L operated)</td> </tr> <tr> <td>UP</td> <td>Compressor overcurrent interruption</td> </tr> <tr> <td>P1-P8</td> <td>Abnormality of indoor units</td> </tr> </tbody> </table>	Display	Contents to be inspected (During operation)	U1	Abnormal high pressure (63H operated)	U2	Abnormal high discharge temperature, high comp. surface temperature, shortage of refrigerant	U3	Open/short of outdoor unit thermistors (TH4, TH33)	U4	Open/short of outdoor unit thermistors (TH3, TH32, TH6, TH7 and TH8)	U5	Abnormal temperature of heat sink	U6	Abnormality of power module	U7	Abnormality of superheat due to low discharge temperature	U8	Abnormality in outdoor fan motor	Ud	Overheat protection	UF	Compressor overcurrent interruption (When Comp. locked)	UH	Current sensor error	UL	Abnormal low pressure (63L operated)	UP	Compressor overcurrent interruption	P1-P8	Abnormality of indoor units																																					
Display	Contents to be inspected (During operation)																																																																			
U1	Abnormal high pressure (63H operated)																																																																			
U2	Abnormal high discharge temperature, high comp. surface temperature, shortage of refrigerant																																																																			
U3	Open/short of outdoor unit thermistors (TH4, TH33)																																																																			
U4	Open/short of outdoor unit thermistors (TH3, TH32, TH6, TH7 and TH8)																																																																			
U5	Abnormal temperature of heat sink																																																																			
U6	Abnormality of power module																																																																			
U7	Abnormality of superheat due to low discharge temperature																																																																			
U8	Abnormality in outdoor fan motor																																																																			
Ud	Overheat protection																																																																			
UF	Compressor overcurrent interruption (When Comp. locked)																																																																			
UH	Current sensor error																																																																			
UL	Abnormal low pressure (63L operated)																																																																			
UP	Compressor overcurrent interruption																																																																			
P1-P8	Abnormality of indoor units																																																																			
	<table border="1"> <thead> <tr> <th>Display</th> <th>Inspection unit</th> </tr> </thead> <tbody> <tr> <td>0</td> <td>Outdoor unit</td> </tr> <tr> <td>1</td> <td>Indoor unit 1</td> </tr> <tr> <td>2</td> <td>Indoor unit 2</td> </tr> </tbody> </table>	Display	Inspection unit	0	Outdoor unit	1	Indoor unit 1	2	Indoor unit 2																																																											
Display	Inspection unit																																																																			
0	Outdoor unit																																																																			
1	Indoor unit 1																																																																			
2	Indoor unit 2																																																																			
	<table border="1"> <thead> <tr> <th>Display</th> <th>Contents to be inspected (When power is turned on)</th> </tr> </thead> <tbody> <tr> <td>F3</td> <td>63L connector(red) is open.</td> </tr> <tr> <td>F5</td> <td>63H connector(yellow) is open.</td> </tr> <tr> <td>F9</td> <td>2 connectors(63H/63L) are open.</td> </tr> <tr> <td>E8</td> <td>Indoor/outdoor communication error (Signal receiving error) (Outdoor unit)</td> </tr> <tr> <td>E9</td> <td>Indoor/outdoor communication error (Transmitting error) (Outdoor unit)</td> </tr> <tr> <td>EA</td> <td>Miswiring of indoor/outdoor unit connecting wire, excessive number of indoor units (4 units or more)</td> </tr> <tr> <td>Eb</td> <td>Miswiring of indoor/outdoor unit connecting wire(converse wiring or disconnection)</td> </tr> <tr> <td>EC</td> <td>Startup time over</td> </tr> <tr> <td>EE</td> <td>Incorrect connection</td> </tr> <tr> <td>E0-E7</td> <td>Communication error except for outdoor unit</td> </tr> </tbody> </table>	Display	Contents to be inspected (When power is turned on)	F3	63L connector(red) is open.	F5	63H connector(yellow) is open.	F9	2 connectors(63H/63L) are open.	E8	Indoor/outdoor communication error (Signal receiving error) (Outdoor unit)	E9	Indoor/outdoor communication error (Transmitting error) (Outdoor unit)	EA	Miswiring of indoor/outdoor unit connecting wire, excessive number of indoor units (4 units or more)	Eb	Miswiring of indoor/outdoor unit connecting wire(converse wiring or disconnection)	EC	Startup time over	EE	Incorrect connection	E0-E7	Communication error except for outdoor unit																																													
Display	Contents to be inspected (When power is turned on)																																																																			
F3	63L connector(red) is open.																																																																			
F5	63H connector(yellow) is open.																																																																			
F9	2 connectors(63H/63L) are open.																																																																			
E8	Indoor/outdoor communication error (Signal receiving error) (Outdoor unit)																																																																			
E9	Indoor/outdoor communication error (Transmitting error) (Outdoor unit)																																																																			
EA	Miswiring of indoor/outdoor unit connecting wire, excessive number of indoor units (4 units or more)																																																																			
Eb	Miswiring of indoor/outdoor unit connecting wire(converse wiring or disconnection)																																																																			
EC	Startup time over																																																																			
EE	Incorrect connection																																																																			
E0-E7	Communication error except for outdoor unit																																																																			

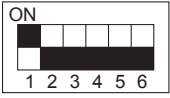
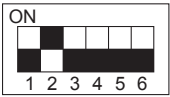
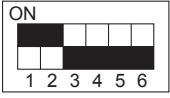
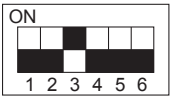
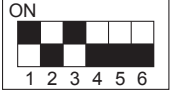
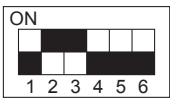
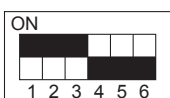
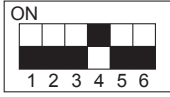
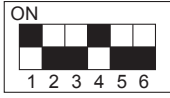
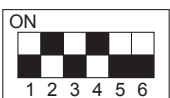
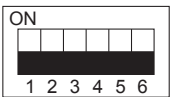

The black square (■) indicates a switch position.

SW2 setting	Display detail	Explanation for display	Unit
	Pipe temperature/Liquid (TH3) -40 to 90	-40 to 90 (When the coil thermistor detects 0°C or below, “-” and temperature are displayed by turns.) (Example) When -10°C; 0.5 s 0.5 s 2 s -□ → 10 → □□	°C
	Discharge temperature (TH4) 3 to 217	3 to 217 (When the discharge thermistor detects 100°C or more, hundreds digit, tens digit and ones digit are displayed by turns.) (Example) When 105°C; 0.5 s 0.5 s 2 s □1 → 05 → □□	°C
	Output step of outdoor FAN 0 to 10	0 to 10	Step
	The number of ON/OFF times of compressor 0 to 9999	0 to 9999 (When the number of times is 100 or more, hundreds digit, tens digit and ones digit are displayed by turns.) (Example) When 42500 times (425 × 100 times); 0.5 s 0.5 s 2 s □4 → 25 → □□	100 times
	Compressor integrating operation times 0 to 9999	0 to 9999 (When it is 100 hours or more, hundreds digit, tens digit and ones digit are displayed by turns.) (Example) When 2450 hours (245 × 10 hours); 0.5 s 0.5 s 2 s □2 → 45 → □□	10 hours
	Compressor operating current 0 to 50	0 to 50 Note: Value after the decimal point will be truncated.	A
	Compressor operating frequency 0 to 225	0 to 255 (When it is 100 Hz or more, hundreds digit, tens digit and ones digit are displayed by turns.) (Example) When 125 Hz; 0.5 s 0.5 s 2 s □1 → 25 → □□	Hz
	Primary LEV opening pulse 0 to 500 Heating: LEV-B Cooling: LEV-A	0 to 500 (When it is 100 pulse or more, hundreds digit, tens digit and ones digit are displayed by turns.) (Example) When 150 pulse; 0.5 s 0.5 s 2 s □1 → 50 → □□	Pulse
	Error postponement code history (1) of outdoor unit	Postponement code display Blinking: During postponement Lighting: Cancellation of postponement “00” is displayed in case of no postponement.	Code display
	Operation mode on error occurring	Operation mode of when operation stops due to error is displayed by setting SW2 like below. (SW2) 	Code display

The black square (■) indicates a switch position.

SW2 setting	Display detail	Explanation for display	Unit
	Pipe temperature/Liquid (TH3) on error occurring -40 to 90	-40 to 90 (When the coil thermistor detects 0°C or below, “-” and temperature are displayed by turns.) (Example) When -15°C; 0.5 s 0.5 s 2 s -□ → 15 → □□ ↑—————↓	°C
	Discharge temperature (TH4) on error occurring 3 to 217	3 to 217 (When the temperature is 100°C or more, the hundreds digit, tens digit and ones digit are displayed by turns.) (Example) When 130°C; 0.5 s 0.5 s 2 s □1 → 30 → □□ ↑—————↓	°C
	Compressor operating current on error occurring 0 to 50	0 to 50	A
	Error history (1) (latest) Alternate display of abnormal unit number and code	When no error history, “0” and “-” are displayed by turns.	Code display
	Error history (2) Alternate display of error unit number and code	When no error history, “0” and “-” are displayed by turns.	Code display
	Thermo ON time 0 to 999	0 to 999 (When it is 100 minutes or more, the hundreds digit, tens digit and ones digit are displayed by turns.) (Example) When 245 minutes; 0.5 s 0.5 s 2 s □2 → 45 → □□ ↑—————↓	Minute
	Test run elapsed time 0 to 120	0 to 120 (When it is 100 minutes or more, the hundreds digit, tens digit and ones digit are displayed by turns.) (Example) When 105 minutes; 0.5 s 0.5 s 2 s □1 → 05 → □□ ↑—————↓	Minute

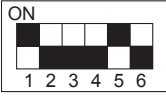
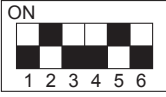
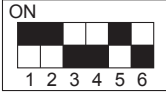
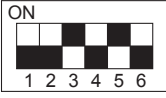

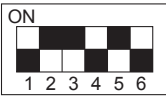
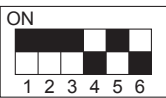
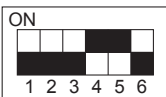

The black square (■) indicates a switch position.

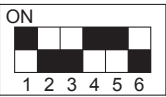
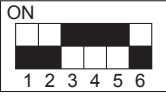
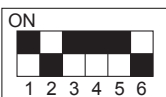
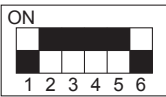
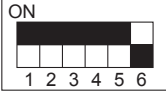
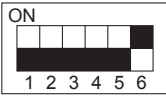
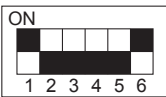
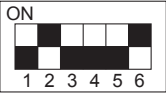
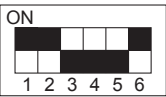
SW2 setting	Display detail	Explanation for display	Unit										
	The number of connected indoor units	0 to 3 (The number of connected indoor units are displayed.)	Unit										
	Capacity setting display	Displayed as an outdoor capacity code. <table border="1" data-bbox="801 519 1070 618"> <thead> <tr> <th>Capacity</th> <th>Code</th> </tr> </thead> <tbody> <tr> <td>SW75/SHW80</td> <td>14</td> </tr> <tr> <td>SW100/SHW112</td> <td>20</td> </tr> </tbody> </table>	Capacity	Code	SW75/SHW80	14	SW100/SHW112	20	Code display				
Capacity	Code												
SW75/SHW80	14												
SW100/SHW112	20												
	Outdoor unit setting information	<ul style="list-style-type: none"> The tens digit (Total display for applied setting) <table border="1" data-bbox="751 757 1318 880"> <thead> <tr> <th>Setting details</th> <th>Display details</th> </tr> </thead> <tbody> <tr> <td>H·P / Cooling only</td> <td>0 : H·P 1 : Cooling only</td> </tr> <tr> <td>Single phase / 3 phase</td> <td>0 : Single phase 2 : 3 phase</td> </tr> </tbody> </table> The ones digit <table border="1" data-bbox="751 936 1318 1016"> <thead> <tr> <th>Setting details</th> <th>Display details</th> </tr> </thead> <tbody> <tr> <td>Defrosting switch</td> <td>0 : Normal 1 : For high humidity</td> </tr> </tbody> </table> <p>(Example) When heat pump, 3 phase and defrosting (normal) are set up, "20" is displayed.</p>	Setting details	Display details	H·P / Cooling only	0 : H·P 1 : Cooling only	Single phase / 3 phase	0 : Single phase 2 : 3 phase	Setting details	Display details	Defrosting switch	0 : Normal 1 : For high humidity	Code display
Setting details	Display details												
H·P / Cooling only	0 : H·P 1 : Cooling only												
Single phase / 3 phase	0 : Single phase 2 : 3 phase												
Setting details	Display details												
Defrosting switch	0 : Normal 1 : For high humidity												
	Indoor pipe temperature/Liquid (TH2(1)) Indoor 1 -39 to 88	-39 to 88 (When the temperature is 0°C or less, "-" and temperature are displayed by turns.)	°C										
	Indoor pipe temperature/Cond./Eva. (TH5(1)) Indoor 1 -39 to 88	-39 to 88 (When the temperature is 0°C or less, "-" and temperature are displayed by turns.)	°C										
	Indoor pipe temperature/Liquid (TH2(2)) Indoor 2 -39 to 88	-39 to 88 (When the temperature is 0°C or less, "-" and temperature are displayed by turns.)	°C										
	Indoor pipe temperature/Cond./Eva. (TH5(2)) Indoor 2 -39 to 88	-39 to 88 (When the temperature is 0°C or less, "-" and temperature are displayed by turns.)	°C										
	Return water temperature 0 to 100	0 to 100	°C										

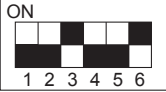
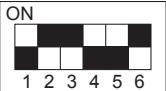
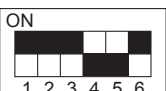

The black square (■) indicates a switch position.

SW2 setting	Display detail	Explanation for display	Unit																
	Flow water temperature 0 to 100	0 to 100	°C																
	2-phase pipe temperature -39 to 88 Heating: TH6 Cooling: T _{63HS}	-39 to 88 (When the temperature is 0°C or less, “-” and temperature are displayed by turns.)	°C																
	Outdoor outside temperature (TH7) -39 to 88	-39 to 88 (When the temperature is 0°C or less, “-” and temperature are displayed by turns.)	°C																
	Outdoor heat sink temperature (TH8) -40 to 200	-40 to 200 (When the temperature is 0°C or less, “-” and temperature are displayed by turns.) (When the thermistor detects 100°C or more, hundreds digit, tens digit and ones digit are displayed by turns.)	°C																
	Discharge superheat SHd 0 to 255 [Cooling = TH4-T _{63HS}] [Heating = TH4-T _{63HS}]	0 to 255 (When the temperature is 100°C or more, hundreds digit, tens digit and ones digit are displayed by turns.)	°C																
	Number of defrost cycles 0 to FFFE	0 to FFFE (in hexadecimal notation) (When more than FF in hex (255 in decimal), the number is displayed in order of 16 ³ 's and 16 ² 's, and 16 ¹ 's and 16 ⁰ 's places. (Example) When 5000 cycles; 0.5 s 0.5 s 2 s □9 → C4 → □□	2 cycles																
	Input current of outdoor unit	0 to 500 (When it is 100 or more, hundreds digit, tens digit and ones digit are displayed by turns.)	0.1 A																
	Secondary LEV opening pulse 0 to 500 Heating: LEV-A Cooling: LEV-B	0 to 500 (When it is 100 pulse or more, hundreds digit, tens digit and ones digit are displayed by turns.)	Pulse																
	U9 error detail history (latest)	<table border="1" data-bbox="836 1688 1385 1924"> <thead> <tr> <th>Description</th> <th>Display</th> </tr> </thead> <tbody> <tr> <td>Normal</td> <td>00</td> </tr> <tr> <td>Oversvoltage error</td> <td>01</td> </tr> <tr> <td>Undersvoltage error</td> <td>02</td> </tr> <tr> <td>Input current sensor error</td> <td rowspan="2">04</td> </tr> <tr> <td>L₁-phase open error</td> </tr> <tr> <td>Abnormal power synchronous signal</td> <td>08</td> </tr> <tr> <td>PFC/IGBT error (SW-V, SHW-V)</td> <td rowspan="2">20</td> </tr> <tr> <td>Undersvoltage</td> </tr> </tbody> </table> <p>• Display examples for multiple errors: Oversvoltage (01) + Undersvoltage (02) = 03 Undersvoltage (02) + Power-sync signal error (08) = 0A L₁ phase open error (04) + PFC/IGBT error (20) = 24</p>	Description	Display	Normal	00	Oversvoltage error	01	Undersvoltage error	02	Input current sensor error	04	L ₁ -phase open error	Abnormal power synchronous signal	08	PFC/IGBT error (SW-V, SHW-V)	20	Undersvoltage	Code display
Description	Display																		
Normal	00																		
Oversvoltage error	01																		
Undersvoltage error	02																		
Input current sensor error	04																		
L ₁ -phase open error																			
Abnormal power synchronous signal	08																		
PFC/IGBT error (SW-V, SHW-V)	20																		
Undersvoltage																			

The black square (■) indicates a switch position.

SW2 setting	Display detail	Explanation for display	Unit
	DC bus voltage 180 to 370	180 to 370 (When it is 100 V or more, hundreds digit, tens digit and ones digit are displayed by turns.)	V
	Error postponement code history (2) of outdoor unit	Postponement code display Blinking: During postponement Lighting: Cancellation of postponement "00" is displayed in case of no postponement.	Code display
	Error postponement code history (3) of outdoor unit	Postponement code display Blinking: During postponement Lighting: Cancellation of postponement "00" is displayed in case of no postponement.	Code display
	Error history (3) (Oldest) Alternate display of abnormal unit number and code	When no error history, "0" and "--" are displayed by turns.	Code display
	Error thermistor display [When there is no error thermistor, "--" is displayed.]	3: Liquid pipe temperature (TH3) 4: Discharge pipe temperature (TH4) 6: 2-phase pipe temperature (TH6) 7: Ambient temperature (TH7) 8: Heat sink temperature (TH8) 32: Suction pipe temperature (TH32) (PUHZ-SHW only) 33: Comp. surface temperature (TH33)	Code display
	Operation frequency on error occurring 0 to 255	0 to 255 (When it is 100 Hz or more, hundreds digit, tens digit and ones digit are displayed by turns.) (Example) When 125 Hz; 0.5 s 0.5 s 2 s □1 → 25 → □□ ↑	Hz
	Fan step on error occurring 0 to 10	0 to 10	Step

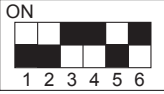

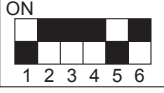
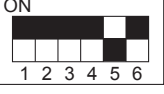
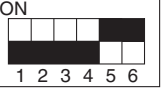
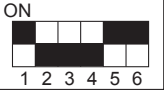
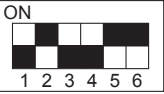
The black square (■) indicates a switch position.

SW2 setting	Display detail	Explanation for display	Unit
	LEV-C opening pulse on error occurring 0 to 480	0 to 480 (When it is 100 pulse or more, hundreds digit, tens digit and ones digit are displayed by turns.) (Example) When 130 pulse; 0.5 s 0.5 s 2 s □1 → 30 → □□ <small>↑</small>	Pulse
	Return water temperature on error occurring 0 to 100	0 to 100	℃
	Indoor pipe temperature/Liquid (TH2) on error occurring -39 to 88	-39 to 88 (When the temperature is 0°C or less, “-” and temperature are displayed by turns.) (Example) When -15°C; 0.5 s 0.5 s 2 s -□ → 15 → □□ <small>↑</small>	℃
	Pressure saturation temperature (T63HS) on error occurring -39 to 88	-39 to 88 (When the temperature is 0°C or less, “-” and temperature are displayed by turns.) (Example) When -15°C; 0.5 s 0.5 s 2 s -□ → 15 → □□ <small>↑</small>	℃
	Outdoor pipe temperature/Cond./Eva. (TH6) on error occurring -39 to 88	-39 to 88 (When the temperature is 0°C or less, “-” and temperature are displayed by turns.) (Example) When -15°C; 0.5 s 0.5 s 2 s -□ → 15 → □□ <small>↑</small>	℃
	Outdoor outside temperature (TH7) on error occurring -39 to 88	-39 to 88 (When the temperature is 0°C or less, “-” and temperature are displayed by turns.) (Example) When -15°C; 0.5 s 0.5 s 2 s -□ → 15 → □□ <small>↑</small>	℃
	Outdoor heat sink temperature (TH8) on error occurring -40 to 200	-40 to 200 (When the temperature is 0°C or less, “-” and temperature are displayed by turns.) (When the temperature is 100°C or more, hundreds digit, tens digit and ones digit are displayed by turns.)	℃

The black square (■) indicates a switch position.

SW2 setting	Display detail	Explanation for display	Unit
	Discharge superheat on error occurring SHd 0 to 255 [Cooling = TH4-T _{63HS} Heating = TH4-T _{63HS}]	0 to 255 (When the temperature is 100°C or more, hundreds digit, tens digit and ones digit are displayed by turns.) (Example) When 150°C; 0.5 s 0.5 s 2 s □1 → 50 → □□ ↑	°C
	Sub cool on error occurring SC 0 to 130 [Cooling = T _{63HS} -TH3 Heating = T _{63HS} -TH2]	0 to 130 (When the temperature is 100°C or more, hundreds digit, tens digit and ones digit are displayed by turns.) (Example) When 115°C; 0.5 s 0.5 s 2 s □1 → 15 → □□ ↑	°C
	Thermo-on time until error stops 0 to 999	0 to 999 (When it is 100 minutes or more, hundreds digit, tens digit and ones digit are displayed by turns.) (Example) When 415 minutes; 0.5 s 0.5 s 2 s □4 → 15 → □□ ↑	Minute
	Indoor pipe temperature/Liquid (TH2 (3)) Indoor 3 -39 to 88	-39 to 88 (When the temperature is 0°C or less, "-" and temperature are displayed by turns.)	°C
	Indoor pipe temperature/Cond./Eva. (TH5 (3)) Indoor 3 -39 to 88	-39 to 88 (When the temperature is 0°C or less, "-" and temperature are displayed by turns.) When there is no indoor unit, "00" is displayed.	°C
	Comp. surface temperature (TH33) -52 to 221	-52 to 221 (When the temperature is 0°C or less, "-" and temperature are displayed by turns.) (When the discharge thermistor detects 100°C or more, hundreds digit, tens digit, and ones digit are displayed by turns.) (Example) When 105°C; 0.5 s 0.5 s 2 s □1 → 05 → □□ ↑	°C

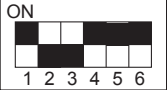
The black square (■) indicates a switch position.

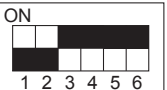
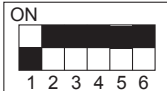
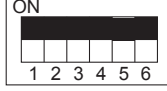
SW2 setting	Display detail	Explanation for display	Unit																
	Controlling status of compressor operating frequency	<p>The following code will be a help to know the operating status of unit.</p> <ul style="list-style-type: none"> •The tens digit <table border="1" data-bbox="850 371 1297 461"> <thead> <tr> <th>Display</th> <th>Compressor operating frequency control</th> </tr> </thead> <tbody> <tr> <td>1</td> <td>Primary current control</td> </tr> <tr> <td>2</td> <td>Secondary current control</td> </tr> </tbody> </table> <ul style="list-style-type: none"> •The ones digit (In this digit, the total number of activated control is displayed.) <table border="1" data-bbox="850 521 1297 763"> <thead> <tr> <th>Display</th> <th>Compressor operating frequency control</th> </tr> </thead> <tbody> <tr> <td>1</td> <td>Preventive control for excessive temperature rise of discharge temperature</td> </tr> <tr> <td>2</td> <td>Preventive control for excessive temperature rise of condensing temperature</td> </tr> <tr> <td>4</td> <td>Frosting preventing control</td> </tr> <tr> <td>8</td> <td>Preventive control for excessive temperature rise of radiator panel</td> </tr> </tbody> </table> <p>(Example) The following controls are activated.</p> <ul style="list-style-type: none"> • Primary current control • Preventive control for excessive temperature rise of condensing temperature • Preventive control for excessive temperature rise of heat sink 	Display	Compressor operating frequency control	1	Primary current control	2	Secondary current control	Display	Compressor operating frequency control	1	Preventive control for excessive temperature rise of discharge temperature	2	Preventive control for excessive temperature rise of condensing temperature	4	Frosting preventing control	8	Preventive control for excessive temperature rise of radiator panel	Code display
Display	Compressor operating frequency control																		
1	Primary current control																		
2	Secondary current control																		
Display	Compressor operating frequency control																		
1	Preventive control for excessive temperature rise of discharge temperature																		
2	Preventive control for excessive temperature rise of condensing temperature																		
4	Frosting preventing control																		
8	Preventive control for excessive temperature rise of radiator panel																		
	Outdoor suction pipe temperature (TH32) -39 to 88	-39 to 88 (When the temperature is 0°C or less, “-” and temperature are displayed by turns.) (Example) When -15°C; 0.5 s 0.5 s 2 s -□ → 15 → □□	°C																
	Indoor pipe temperature/liquid (TH2(4)) -39 to 88	-39 to 88 (When the temperature is 0°C or less, “-” and temperature are displayed by turns.) (Example) When 105°C; 0.5 s 0.5 s 2 s □1 → 05 → □□	°C																
	Indoor pipe temperature/Cond./Eva. (TH5(4)) indoor 4 -39 to 88	-39 to 88 (When the temperature is 0°C or less, “-” and temperature are displayed by turns.) When there is no indoor unit, "00" is displayed.	°C																

10-1. Request code list

Certain indoor/outdoor combinations do not have the request code function; therefore, no request codes are displayed. Refer to indoor unit service manual for how to use the controllers and request codes for indoor unit.

Request code	Request content	Description (Display range)	Unit	Remarks
0	Operation state	Refer to 10-1-1. Detail Contents in Request Code.	—	
1	Compressor-Operating current (rms)	0–50	A	
2	Compressor-Accumulated operating time	0–9999	10 hours	
3	Compressor-Number of operation times	0–9999	100 times	
4	Discharge temperature (TH4)	3–217	°C	
5	Outdoor unit -Liquid pipe 1 temperature (TH3)	–40–90	°C	
6				
7	Outdoor unit-2-phase pipe temperature (TH6)	–39–88	°C	
8	Outdoor unit-Suction pipe temperature (TH32)	–39–88	°C	SHW model only
9	Outdoor unit-Outside air temperature (TH7)	–39–88	°C	
10	Outdoor unit-Heat sink temperature (TH8)	–40–200	°C	
11				
12	Discharge superheat (SHd)	0–255	°C	
13	Sub-cool (SC)	0–130	°C	
14	Condensing temperature (T _{63HS})	–39–88	°C	
15				
16	Compressor-Operating frequency	0–255	Hz	
17	Compressor-Target operating frequency	0–255	Hz	
18	Outdoor unit-Fan output step	0–10	Step	
19	Outdoor unit-Fan 1 speed (Only for air conditioners with DC fan motor)	0–9999	rpm	
20	Outdoor unit-Fan 2 speed (Only for air conditioners with DC fan motor)	0–9999	rpm	"0" is displayed if the air conditioner is a single-fan type.
21				
22	LEV (A) opening	0–500	Pulses	
23	LEV (B) opening	0–500	Pulses	
24	LEV (C) opening	0–500	Pulses	SHW model only
25	Primary current	0–50	A	
26	DC bus voltage	180–370	V	
27				
28				
29				
30				
31				
32				
33				
34				
35				
36				
37				
38				
39				
40				
41				
42				
43				
44				
45				
46				
47				
48	Thermostat ON operating time	0–999	Minutes	
49				

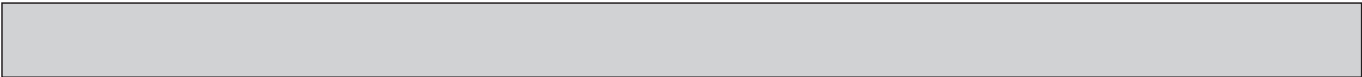

Request code	Request content	Description (Display range)	Unit	Remarks
50				
51	Outdoor unit-Control state	Refer to 10-1-1.Detail Contents in Request Code.	-	
52	Compressor-Frequency control state	Refer to 10-1-1.Detail Contents in Request Code.	-	
53	Outdoor unit-Fan control state	Refer to 10-1-1.Detail Contents in Request Code.	-	
54	Actuator output state	Refer to 10-1-1.Detail Contents in Request Code.	-	
55	Error content (U9)	Refer to 10-1-1.Detail Contents in Request Code.	-	
56				
57				
58				
59				
60				
61				
62				
63				
64				
65				
66				
67				
68				
69				
70	Outdoor unit-Capacity setting display	Refer to 11-1-1.Detail Contents in Request Code.	-	
71	Outdoor unit-Setting information	Refer to 11-1-1.Detail Contents in Request Code.	-	
72				
73				
74				
75				
76				
77				
78				
79				
80				
81				
82				
83				
84				
85				
86				
87				
88				
89				
90	Outdoor unit-Microprocessor version information	Examples) Ver 5.01 → "0501"	Ver	
91	Outdoor unit-Microprocessor version information (sub No.)	Auxiliary information (displayed after version information) Examples) Ver 5.01 A000 → "A000"	-	
92				
93				
94				
95				
96				
97				
98				
99				
100	Outdoor unit - Error postponement history 1 (latest)	Displays postponement code. (" - " is displayed if no postponement code is present)	Code	
101	Outdoor unit - Error postponement history 2 (previous)	Displays postponement code. (" - " is displayed if no postponement code is present)	Code	
102	Outdoor unit - Error postponement history 3 (last but one)	Displays postponement code. (" - " is displayed if no postponement code is present)	Code	

Request code	Request content	Description (Display range)	Unit	Remarks
103	Error history 1 (latest)	Displays error history. ("-" is displayed if no history is present.)	Code	
104	Error history 2 (second to last)	Displays error history. ("-" is displayed if no history is present.)	Code	
105	Error history 3 (third to last)	Displays error history. ("-" is displayed if no history is present.)	Code	
106	Abnormal thermistor display (TH3/TH6/TH7/TH8)	3 : TH3 6 : TH6 7 : TH7 8 : TH8 0 : No thermistor error	Sensor number	
107	Operation mode at time of error	Displayed in the same way as request code "0".	-	
108	Compressor-Operating current at time of error	0-50	A	
109	Compressor-Accumulated operating time at time of error	0-9999	10 hours	
110	Compressor-Number of operation times at time of error	0-9999	100 times	
111	Discharge temperature at time of error	3-217	°C	
112	Outdoor unit -Liquid pipe 1 temperature (TH3) at time of error	-40-90	°C	
113				
114	Outdoor unit-2-phase pipe temperature (TH6) at time of error	-39-88	°C	
115				
116	Outdoor unit-Outside air temperature (TH7) at time of error	-39-88	°C	
117	Outdoor unit-Heat sink temperature (TH8) at time of error	-40-200	°C	
118	Discharge superheat (SHd) at time of error	0-255	°C	
119	Sub-cool (SC) at time of error	0-130	°C	
120	Compressor-Operating frequency at time of error	0-255	Hz	
121	Outdoor unit at time of error • Fan output step	0-10	Step	
122	Outdoor unit at time of error • Fan 1 speed (Only for air conditioners with DC fan)	0-9999	rpm	
123	Outdoor unit at time of error • Fan 2 speed (Only for air conditioners with DC fan)	0-9999	rpm	"0" is displayed if the air conditioner is a single-fan type.
124				
125	LEV (A) opening at time of error	0-500	Pulses	
126	LEV (B) opening at time of error	0-500	Pulses	
127				
128				
129	Condensing temperature (T _{63HS}) at the time of error	-39-88	°C	
130	Thermostat ON time until operation stops due to error	0-999	Minutes	

10-1-1. Detail Contents in Request Code

[Operation state] (Request code : "0")

Data display

□ □ C 4

Relay output state
Operation mode

Operation mode

Display	Operation mode
0	STOP • FAN
C	COOL • DRY
H	HEAT
d	DEFROST

Relay output state

Display	Power currently supplied to compressor	Compressor	Four-way valve	Solenoid valve
0	—	—	—	—
1				ON
2			ON	
3			ON	ON
4		ON		
5		ON		ON
6		ON	ON	
7		ON	ON	ON
8	ON			
A	ON		ON	

[Outdoor unit – Control state] (Request code : "51")

Data display	State
0 0 0 0	Normal
0 0 0 1	Preparing for heat operation
0 0 0 2	Defrost

[Compressor – Frequency control state] (Request code : "52")

Data display

0 0 * *

Frequency control state ②
Frequency control state ①

Frequency control state ①

Display	Current limit control
0	No current limit
1	Primary current limit control is ON.
2	Secondary current limit control is ON.

Frequency control state ②

Display	Discharge temperature overheat prevention	Condensation temperature overheat prevention	Anti-freeze protection control	Heat sink temperature overheat prevention
0				
1	Controlled			
2		Controlled		
3	Controlled	Controlled		
4			Controlled	
5	Controlled		Controlled	
6		Controlled	Controlled	
7	Controlled	Controlled	Controlled	
8				Controlled
9	Controlled			Controlled
A		Controlled		Controlled
b	Controlled	Controlled		Controlled
C			Controlled	Controlled
d	Controlled		Controlled	Controlled
E		Controlled	Controlled	Controlled
F	Controlled	Controlled	Controlled	Controlled

[Fan control state] (Request code : "53")

Data display

0 0 * *

Fan step correction value by heat sink temperature overheat prevention control
Fan step correction value by cool condensation temperature overheat prevention control

Display	Correction value
- (minus)	-1
0	0
1	+1
2	+2

[Actuator output state] (Request code : "54")

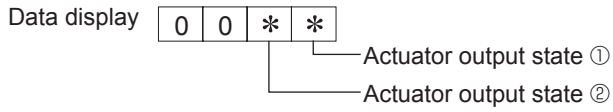

Actuator output state ①

Display	SV1	Four-way valve	Compressor	Compressor is warming up
0				
1	ON			
2		ON		
3	ON	ON		
4			ON	
5	ON		ON	
6		ON	ON	
7	ON	ON	ON	
8				ON
9	ON			ON
A		ON		ON
b	ON	ON		ON
C			ON	ON
d	ON		ON	ON
E		ON	ON	ON
F	ON	ON	ON	ON

Actuator output state ②

Display	52C	SV2	SS
0			
1	ON		
2		ON	
3	ON	ON	
4			ON
5	ON		ON
6		ON	ON
7	ON	ON	ON

[Error content (U9)] (Request code : "55")

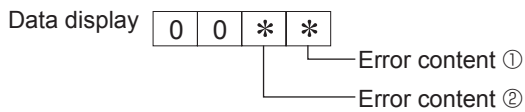

Error content ①

● : Detected

Display	Oversvoltage error	Undersvoltage error	L ₁ -phase open error	Power synchronizing signal error
0				
1	●			
2		●		
3	●	●		
4			●	
5	●		●	
6		●	●	
7	●	●	●	
8				●
9	●			●
A		●		●
b	●	●		●
C			●	●
d	●		●	●
E		●	●	●
F	●	●	●	●

Error content ②

● : Detected

Display	Converter Fo error	PAM error
0		
1	●	
2		●
3	●	●

[Outdoor unit –Capacity setting display] (Request code : "70")

Data display	Capacity
9	35
10	50
11	60
14	71
20	100
25	125
28	140
40	200
50	250

[Outdoor unit – Setting information] (Request code : "71")

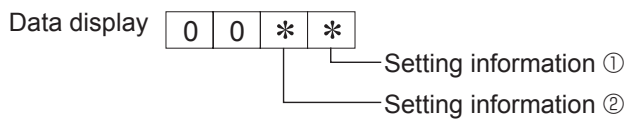

Setting information ①

Display	Defrost mode
0	Standard
1	For high humidity

Setting information ②

Display	Single-/ 3-phase	Heat pump/ cooling only
0	Single-phase	Heat pump
1		Cooling only
2	3-phase	Heat pump
3		Cooling only

PUHZ-SHW80VAA.UK

PUHZ-SHW112VAA.UK

PUHZ-SHW80YAA.UK

PUHZ-SHW112YAA.UK

PUHZ-SHW80VAA-BS.UK

PUHZ-SHW112VAA-BS.UK

PUHZ-SHW80YAA-BS.UK

PUHZ-SHW112YAA-BS.UK

PUHZ-SW100VAA.UK

PUHZ-SW100YAA.UK

PUHZ-SW100VAA-BS.UK

PUHZ-SW100YAA-BS.UK

OPERATING PROCEDURE

1. Removing the service panel and top panel

- (1) Remove the service panel fixing screws (3 for front and 1 for right/ 5 × 12), then slide the service panel downward to remove it.

(The service panel is fixed to the side panel (R) with a hook on the right side.)

- (2) Remove the top panel fixing screws (3 for front, 3 for rear and 1 for right/ 5 × 12) to remove the top panel.

Note 1: When removing service panel and top panel at the same time, count 2 less screws since they share a screws.

PHOTOS

Photo 1

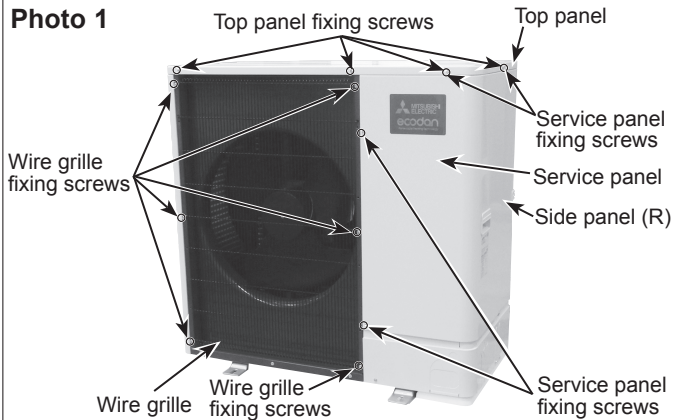

2. Removing the fan motor (MF1)

- (1) Remove the service panel. (See Photo 1)
- (2) Remove the top panel. (See Photo 1)
- (3) Remove the wire grille fixing screws (6 for front/ 5 × 12), then slide the wire grille upward to remove it. (See Photo 1)
- (4) Remove the screw of nut (1 for front/ M6), then slide the propeller fan forward to remove it.
- (5) Disconnect the connector CNF1 (WH) on the controller circuit board in the electrical parts box.
- (6) Loosen the clamps for the lead wire on motor support and separator.
- (7) Loosen the edge cover for the lead wire on separator.
- (8) Remove the fan motor fixing screws (4 for front/ 5 × 20) to remove the fan motor.

Note 1: When attaching the fan motor, make sure to route the cable through the hook below the fan motor and fix firmly with the clamp.

Note 2: Tighten the propeller fan with a torque of 5.7 ± 0.3 N·m.

Photo 2-1

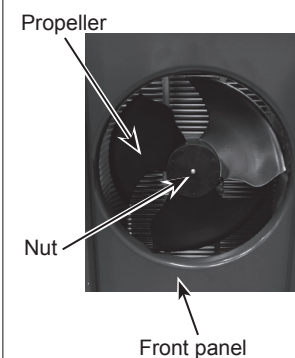
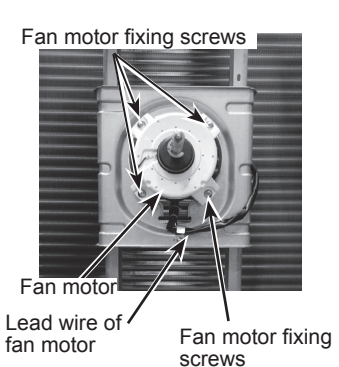

Photo 2-2



3. Removing the electrical parts box

- (1) Remove the service panel. (See Photo 1)
- (2) Remove the top panel. (See Photo 1)
- (3) Disconnect the power supply cable from terminal block.
- (4) Disconnect the indoor/outdoor connecting wire from terminal block.
- (5) Loosen the cable strap for the lead wire on the comp case (front).
- (6) Disconnect the connectors CNF1 (WH), TH3 (WH), TH4 (WH), TH7/6 (RD), TH32 (BK)^{(*)1}, TH33 (YE), 63H (YE), 63L (RD), 63HS (WH), 21S4 (GN), LEV-A (WH), LEV-B (RD) and LEV-C (BU)^{(*)1} from the controller circuit board.

<Symbols on the board>

- Fan motor (CNF1)
 - Thermistor <Liquid> (TH3)
 - Thermistor <Discharge> (TH4)
 - Thermistor <Ambient/2-Phase Pipe> (TH7/6)
 - Thermistor <Suction> (TH32)^{(*)1}
 - Thermistor <Comp. Surface> (TH33)
 - High pressure switch (63H)
 - Low pressure switch (63L)
 - High pressure sensor (63HS)
 - 4-way valve (21S4)
 - LEV (LEV-A, LEV-B, LEV-C)^{(*)1}
- (7) Disconnect the connectors ACL1 (RD), ACL2(WH) and ACL3(BK) on reactors in the separator.*2
- (8) Remove the cover panel (front) fixing screws (1 for front and 1 for right/ 5 × 12) to remove the cover panel (front).
- (9) Remove the comp case (top) fixing screws (2 for front and 1 for right/ 4 × 10) to remove the comp case (top).
- (10) Remove the comp case (front) fixing screws (4 for front and 2 for right/ 4 × 10) to remove the comp case (front).
- (11) Loosen the clamps, fasteners, band and cable straps for the lead wire in the electrical parts box and separator.
- (12) To disconnect the COMP lead wire, remove the terminal cover.
- (13) Remove the electrical parts box fixing screws (2 for front/ 5 × 12), then slide the electrical parts box upward to remove it.
(The electrical parts box is fixed to the side panel (R) with a hook on the right side, and to the separator duct with a hook on the left side.)

*1 For SHW model only

*2 For SW100Y and SHW-Y model only

Photo 3-1

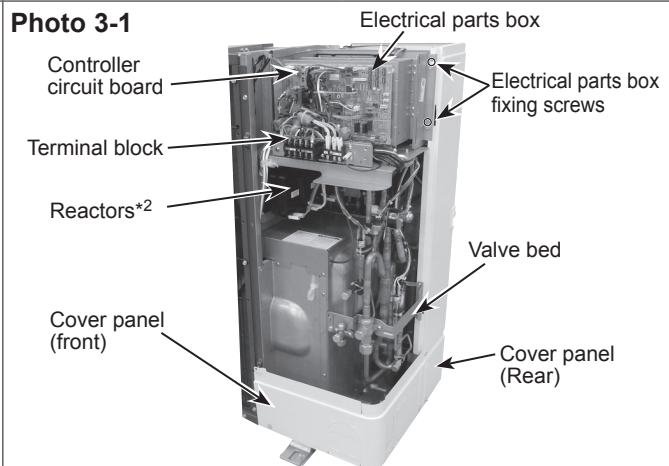
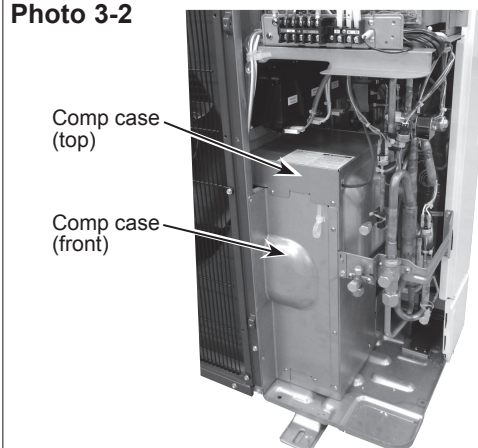

Photo 3-2



OPERATING PROCEDURE

4. Disassembling the electrical parts box (V model only)

- (1) Remove the electrical parts box. (See Photo 3-1)
- (2) Disconnect all the connectors on the controller circuit board.
- (3) To remove the controller circuit board, release it from the support.
- (4) Remove the cont base front fixing screws (3 for front/ 4 × 10) to remove the cont base front.
(The cont base front is fixed to the electrical parts box with a hook on the left side.)
- (5) Disconnect all the connectors on the power circuit board.
- (6) To remove the power circuit board, remove the power circuit board fixing screws (4 for front/ 3 × 12, 2 for front/ 4 × 18, and 1 for front/ 4 × 10), then release the board from the support.
- (7) Remove the reactor (DCL1, DCL2, DCL3) fixing screws (6 for rear/ 4 × 10) to remove the reactor, then disconnect the connectors on reactor.
- (8) Remove the thermistor <Heat sink> (TH8) fixing screws (2 for front/ 3 × 12) to remove the thermistor <Heat sink> (TH8).
- (9) To remove the heat sink, remove the heat sink duct fixing screws (6 for front/ 4 × 10), then slide the heat sink duct sideways to remove the heat sink.

Note 1: When reassembling the electrical parts box, make sure the wirings are correct.

PHOTOS

Photo 4-1

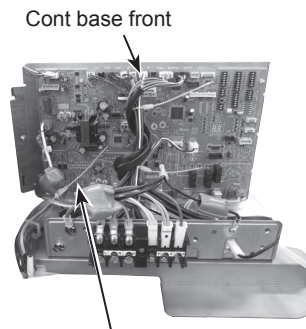

Cont base front
Controller circuit board

Photo 4-2

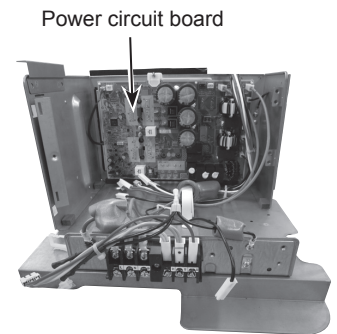

Power circuit board

Photo 4-3

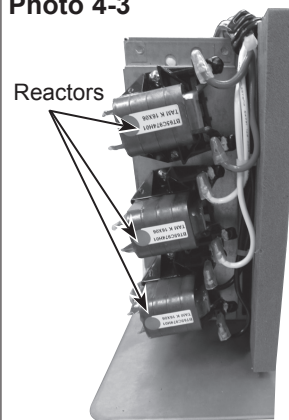

Reactors

Photo 4-4

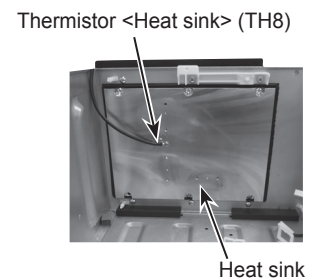

Thermistor <Heat sink> (TH8)

Heat sink

5. Disassembling the electrical parts box (Y model only)

- (1) Remove the electrical parts box. (See Photo 3-1)
- (2) Disconnect all the connectors on the controller circuit board.
- (3) To remove the controller circuit board, release it from the support.
- (4) Remove the cont base front fixing screws (3 for front/ 4 × 10) to remove the cont base front.
(The cont base front is fixed to the electrical parts box with a hook on the left side.)
- (5) Disconnect all the connectors on the noise filter circuit board.
- (6) To remove the noise filter circuit board, release it from the support.
- (7) Remove the cont base fixing screws (3 for front/ 4 × 10) to remove the cont base.
(The cont base is fixed to the electrical parts box with a hook on the left side.)
- (8) Disconnect all the connectors on the converter circuit board. (The converter circuit board is attached to the rear side of the cont base.)
- (9) To remove the converter circuit board, release it from the support.
- (10) Disconnect all the connectors on the power circuit board.
- (11) To remove the power circuit board, remove the power circuit board fixing screws (4 for front/ 4 × 14), then release the board from the support.
- (12) Remove the thermistor <Heat sink> (TH8) fixing screws (2 for front/ 3 × 12) to remove the thermistor <Heat sink> (TH8).
- (13) Disconnect the connectors on reactor (ACL4), resistor (RS) and capacitor (CK) first, then remove the fixing screws of reactor, resistor and capacitor (4 for front/ 4 × 10), and remove reactor, resistor and capacitor.
- (14) To remove the heat sink, remove the heat sink duct fixing screws (6 for front/ 4 × 18), then slide the heat sink duct sideways to remove the heat sink.

Note 1: When reassembling the electrical parts box, make sure the wirings are correct.

Photo 5-1

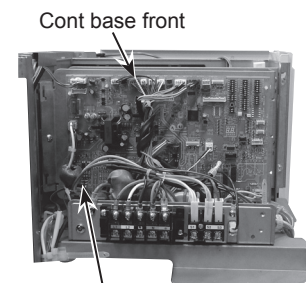

Cont base front
Controller circuit board

Photo 5-2

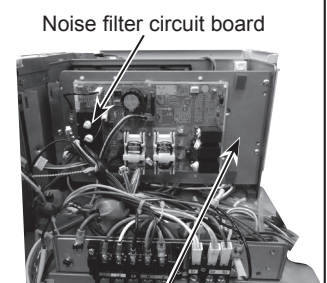

Noise filter circuit board
Cont base

Photo 5-3

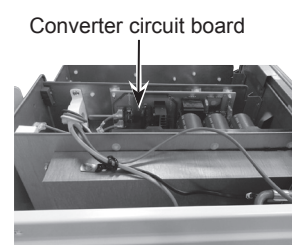

Converter circuit board

Photo 5-4

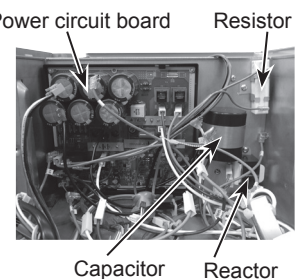

Power circuit board Resistor
Capacitor Reactor

Photo 5-5

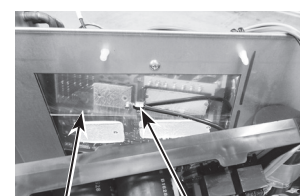

Heat sink

Thermistor <Heat sink> (TH8)

OPERATING PROCEDURE

6. Removing the thermistor <2-Phase Pipe> (TH6)

- (1) Remove the service panel. (See Photo 1)
- (2) Remove the top panel. (See Photo 1)
- (3) Disconnect the connector TH7/6 (RD) on the controller circuit board in the electrical parts box. (See Photo 3-1)
- (4) Loosen the fasteners and wire clips for the lead wire in the electrical parts box.
- (5) Loosen the clamp for the lead wire on the rear of electrical parts box.
- (6) Pull out the thermistor <2-phase pipe> (TH6) from thermistor clip.

Note 1: When replacing thermistor <2-phase pipe> (TH6), replace it together with thermistor <Ambient> (TH7) since they are combined together. Refer to procedure No.7 to remove the thermistor <Ambient> (TH7).

PHOTOS

Photo 6

Thermistor <2-Phase Pipe> (TH6)

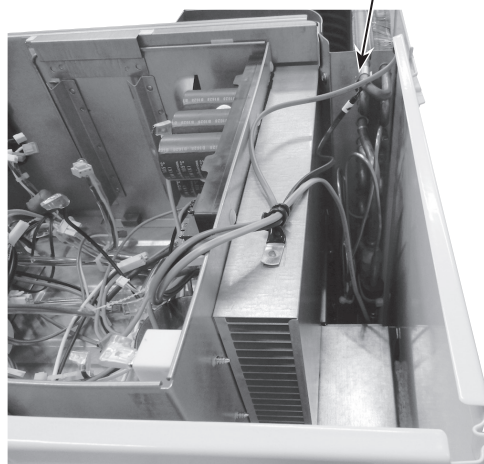

7. Removing the thermistor <Ambient> (TH7)

- (1) Remove the service panel. (See Photo 1)
- (2) Remove the top panel. (See Photo 1)
- (3) Disconnect the connector TH7/6 (RD) on the controller circuit board in the electrical parts box. (See Photo 3-1)
- (4) Loosen the fasteners and wire clips for the lead wire in the electrical parts box.
- (5) Loosen the clamps for the lead wire on rear of electrical parts box.
- (6) Remove the sensor holder fixing screw (1 for rear/ 5 × 12) to remove the sensor holder.
- (7) Pull out the thermistor <Ambient> (TH7) from sensor holder.

Note 1: When replacing thermistor <Ambient> (TH7), replace it together with thermistor <2-phase pipe> (TH6), since they are combined together. Refer to procedure No.6 to remove the thermistor <2-phase pipe>(TH6).

Photo 7

Thermistor <Ambient> (TH7) and sensor holder

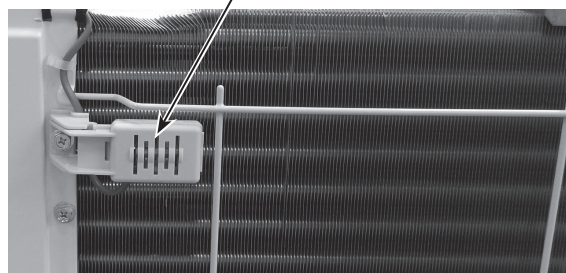

8. Removing the thermistor <Liquid> (TH3)

- (1) Remove the service panel. (See Photo 1)
- (2) Remove the top panel. (See Photo 1)
- (3) Remove the cover panel (front). (See Photo 3-1)
- (4) Remove the cover panel (rear) fixing screws (2 for rear and 2 for right/ 5 × 12) to remove the cover panel (rear). (See Photo 3-1)
- (5) Remove the valve bed fixing screws (2 for front/ 5 × 12) on the side panel (R). (See Photo 3-1)
- (6) Remove the electrical parts box fixing screws (2 for front/ 5 × 12). (See Photo 3-1)
- (7) Remove the sensor holder.
- (8) Remove the side panel (R) fixing screws (3 for rear/ 5 × 12) to remove the side panel (R). (See Photo 1)
- (9) Disconnect the connector TH3 (WH) on the controller circuit board in the electrical parts box. (See Photo 3-1)
- (10) Loosen the fasteners and wire clips for the lead wire in the electrical parts box.
- (11) Loosen the clamp for the lead wire on the rear of electrical parts box.
- (12) Pull out the thermistor <Liquid> (TH3) from thermistor clip.

Photo 8

Thermistor <Liquid> (TH3)



OPERATING PROCEDURE

9. Removing the thermistor <Discharge> (TH4), thermistor <Suction> (TH32)^(*) and thermistor <Comp. Surface> (TH33)

- (1) Remove the service panel. (See Photo 1)
- (2) Remove the top panel. (See Photo 1)
- (3) Remove the cover panel (front). (See Photo 3-1)
- (4) Remove the comp case (top). (See Photo 3-2)
- (5) Remove the comp case (front). (See Photo 3-2)
- (6) Disconnect the connectors TH4 (WH), TH32 (BK)^(*) and TH33 (YE) on the controller circuit board in the electrical parts box. (See Photo 3-1)
- (7) Loosen the fasteners, wire clip and cable straps for the lead wire in the electrical parts box.
- (8) Loosen the bands for the lead wire.
- (9) Loosen the clamps for the lead wire in the separator.
- (10) Loosen the edge cover for the lead wire on the comp case (side).
- (11) Pull out the thermistor <Discharge> (TH4) from thermistor holder.
- (12) Pull out the thermistor <Comp. Surface> (TH33) from thermistor holder.
- (13) Loosen the lead wires fixed to the pipes with bands.^{*1}
- (14) Pull out the thermistor <Suction> (TH32) from thermistor clip.^{*1}

^{*1} For SHW-model only

PHOTOS

Photo 9-1

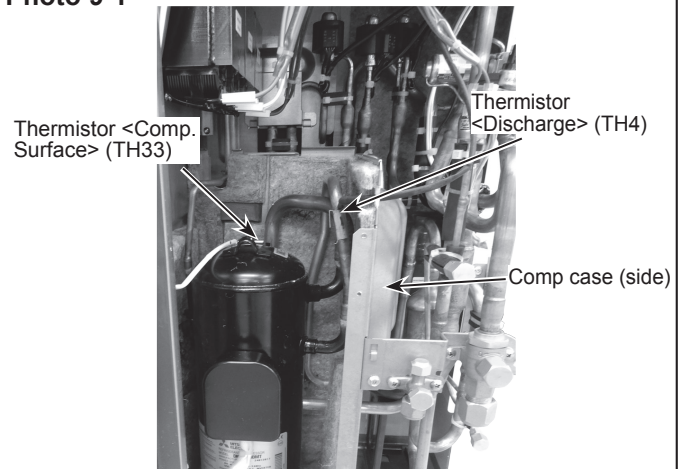
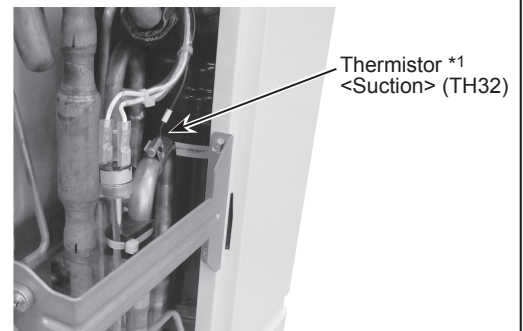

Photo 9-2



10. Removing the 4-way valve coil (21S4), LEV coil (LEV-A, LEV-B, LEV-C^(*)), lead wire for high pressure switch, low pressure switch, and high pressure sensor.

- (1) Remove the electrical parts box. (See Photo 3-1)
 - (2) Loosen the bands for the lead wire.
- [Removing the 4-way valve coil]
- (3) Remove the 4-way valve coil fixing screw (1 for right/ M5) to remove the 4-way valve coil.
 - (4) Slide the 4-way valve coil rightward to remove it.
- [Removing the LEV coil]
- (3) Loosen the lead wires fixed to the pipes with bands.
 - (4) Slide the LEV coil upward to remove it.
- [Removing the lead wire for high pressure switch]
- (3) Disconnect the lead wire from the high pressure switch.
- [Removing the lead wire for low pressure switch]
- (3) Loosen the lead wires fixed to the pipes with band.
 - (4) Disconnect the lead wire from the low pressure switch.
- [Removing the lead wire for high pressure sensor]
- (3) Disconnect the lead wire from the high pressure sensor.

Note1 : For SHW model, please see Photo 11.

^{*1} For SHW-model only

Photo 10 (SW100 model)

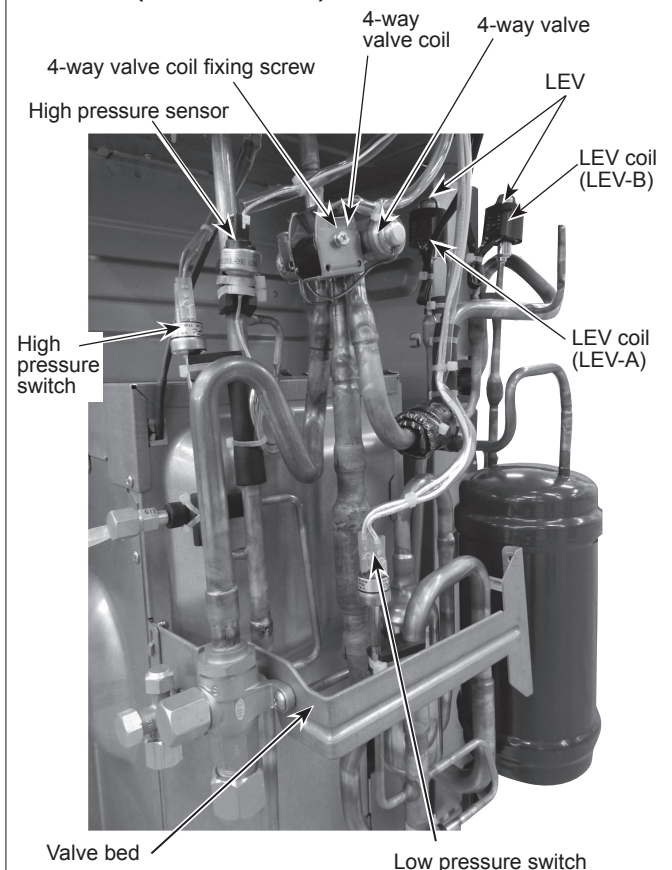

OPERATING PROCEDURE

11. Removing the 4-way valve, LEV (LEV-A, LEV-B, LEV-C^(*)), high pressure switch, low pressure switch and high pressure sensor.

- (1) Remove the service panel. (See Photo 1)
- (2) Recover refrigerant.
- (3) Remove the electrical parts box. (See Photo 3-1)
- (4) Remove the valve bed fixing screws (3 for front/ 5 × 12) and the ball valve and stop valve fixing screws (4 for front/ 5 × 16) to remove the valve bed.
- (5) Remove the side panel (R). (See Photo 1)

[Removing the 4-way valve]

- (6) Remove the 4-way valve coil.
- (7) Remove the welded part of 4-way valve (4 positions) to remove the 4-way valve.

[Removing the LEV]

- (6) Remove the LEV coil.
- (7) Loosen the LEV fixed to the pipe with band and rubber mount.
- (8) Remove the welded part of LEV (2 positions) to remove the LEV.

[Removing the pressure switch]

- (6) Disconnect the lead wire from the pressure switch.
- (7) Loosen the pressure switch fixed to the pipe with band and rubber mount.
- (8) Remove the welded part of pressure switch (1 position) to remove the pressure switch.

[Removing the high pressure sensor]

- (6) Disconnect the lead wire from the high pressure sensor.
- (7) Loosen the high pressure sensor fixed to the pipe with band and rubber mount.
- (8) Remove the welded part of high pressure sensor (1 position) to remove the high pressure sensor.

Note 1: Recover refrigerant without spreading it in the air.

Note 2: When installing the following parts, cover it with a wet cloth to prevent it from heating as the temperature below, then braze the pipes so that the inside of pipes are not oxidized;

- 4-way valve, 120°C or more
- LEV, 120°C or more
- High pressure switch, 100°C or more
- Low pressure switch, 100°C or more
- High pressure sensor, 100°C or more

^{*1} For SHW-model only

12. Removing the compressor (MC)

- (1) Remove the service panel. (See Photo 1)
- (2) Recover refrigerant.
- (3) Remove the electrical parts box. (See Photo 3-1)
- (4) Remove the valve bed. (See Photo 3-1)
- (5) Remove the side panel (R). (See Photo 1)
- (6) Remove the thermistor <Liquid> (TH3), thermistor <2-Phase Pipe> (TH6), thermistor <Ambient> (TH7), thermistor <Discharge> (TH4), thermistor <Suction> (TH32)^(*) and thermistor <Comp. Surface> (TH33).
- (7) Remove the 4-way valve coil and LEV coil.
- (8) Disconnect the lead wire from the pressure switch and sensor.
- (9) Remove the comp case (side) fixing screws (1 for front and 1 for right/ 4 × 10) to remove the comp case (side).
- (10) Remove the hic top support fixing screw (1 for front/ 4 × 10) to remove the hic top support.^{*1}
- (11) Remove the welded part (Joint part of the compressor, heat exchanger and receiver) of piping (SW100-model for 6 positions, SHW-model for 7 positions), then slide the piping upward to remove it.
- (12) Remove the compressor fixing nuts (3 for top/ M6) to remove the compressor.

Note 1: Recover refrigerant without spreading it in the air.
Note 2: Tighten the nuts of compressor with a torque of 4 ± 0.4 N·m.

^{*1} For SHW-model only

PHOTOS

Photo 11 (SHW model)

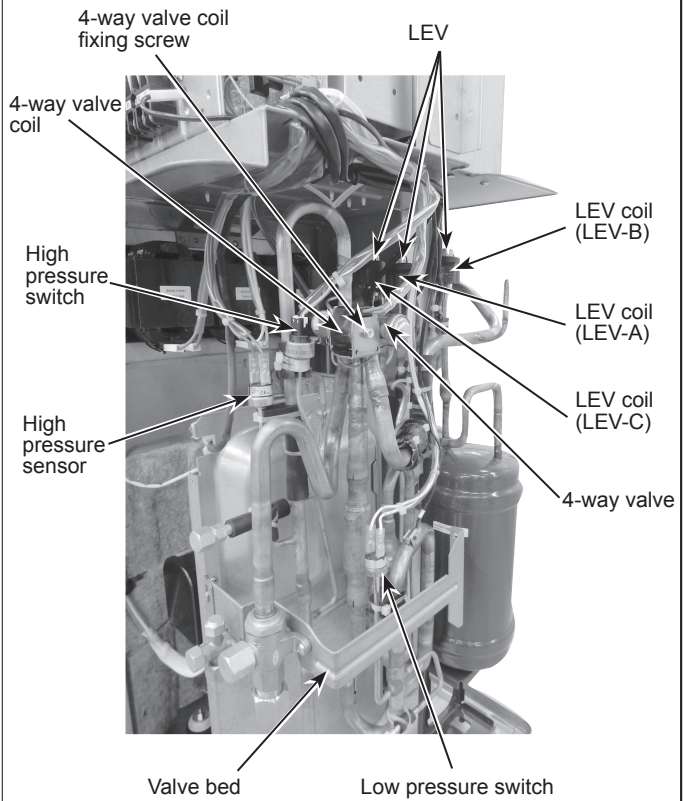
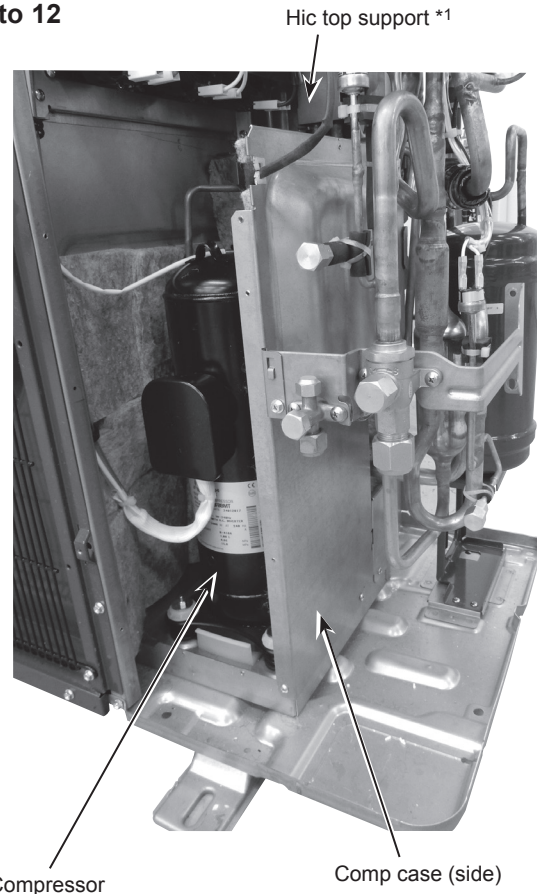

Photo 12



OPERATING PROCEDURE

13. Removing the receiver

- (1) Remove the service panel. (See Photo 1)
- (2) Recover refrigerant.
- (3) Remove the piping.
- (4) Remove the receiver leg fixing screws (2 for top/ 4 × 10), then slide the receiver upward to remove it.
(The receiver is fixed to the base with a hook on the bottom.)

Note 1: Recover refrigerant without spreading it in the air.

PHOTOS

Photo 13

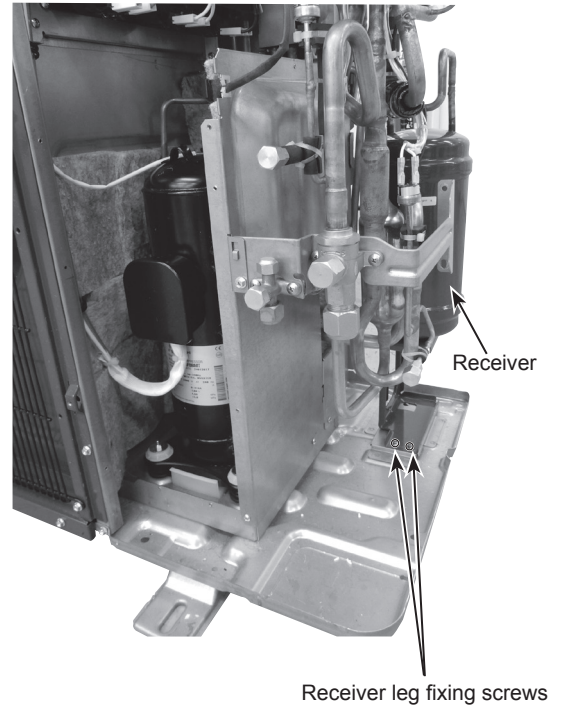

14. Removing the reactor (ACL1, ACL2, ACL3) (Y model only)

- (1) Remove the electrical parts box. (See Photo 3-1)
- (2) Remove the reactor assy fixing screws (8 for right/ 4 × 10), then slide the reactor assy upward to remove it.
- (3) Remove the reactor fixing screws (4 for front/ 4 × 10) to remove the reactor on the reactor assy.

Note 1: Pay extra attention when handling the reactor since it is very heavy (4.1 kg).

Photo 14

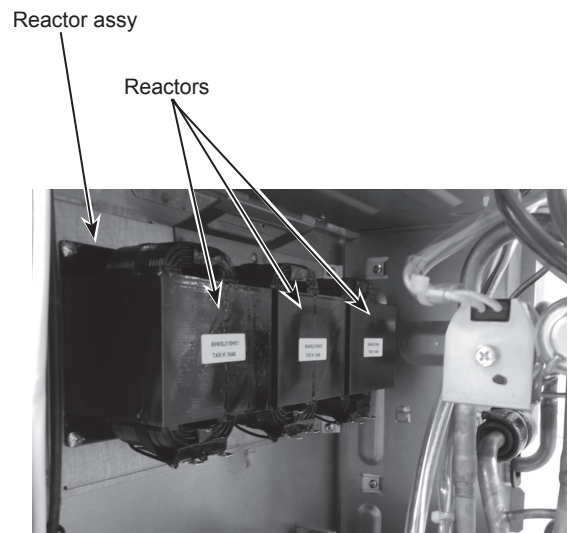

PUHZ-SW75VAA.UK
 PUHZ-SW75VAA-BS.UK
 PUHZ-SW75VAA-SC.UK

PUHZ-SW75YAA.UK
 PUHZ-SW75YAA-BS.UK
 PUHZ-SW75YAA-SC.UK

OPERATING PROCEDURE

1. Removing the service panel and top panel

- (1) Remove the service panel fixing screws (3 for front and 1 for right/ 5 × 12), then slide the service panel downward to remove it.
 (The service panel is fixed to the side panel (R) with a hook on the right side.)
- (2) Remove the top panel fixing screws (3 for front, 3 for rear and 1 for right/ 5 × 12) to remove the top panel.

Note 1: When removing service panel and top panel at the same time, count 2 less screws since they share a screws.

2. Removing the fan motor (MF1)

- (1) Remove the service panel. (See Photo 1)
- (2) Remove the top panel. (See Photo 1)
- (3) Remove the wire grille fixing screws (6 for front/ 5 × 12), then slide the wire grille upward to remove it. (See Photo 1)
- (4) Remove the screw of nut (1 for front/ M6), then slide the propeller fan forward to remove it.
- (5) Disconnect the connector CNF1 (WH) on the controller circuit board in the electrical parts box. (See Photo 4)
- (6) Loosen the clamps for the lead wire on motor support and separator.
- (7) Loosen the edge cover for the lead wire on separator.
- (8) Remove the fan motor fixing screws (4 for front/ 5 × 20) to remove the fan motor.

Note 1: When attaching the fan motor, make sure to route the cable through the hook below the fan motor and fix firmly with the clamp.

Note 2: Tighten the propeller fan with a torque of 5.7 ± 0.3 N·m.

3. Removing the electrical parts box

- (1) Remove the service panel. (See Photo 1)
- (2) Remove the top panel. (See Photo 1)
- (3) Disconnect the power supply cable from terminal block.
- (4) Disconnect the indoor/outdoor connecting wire from terminal block.
- (5) Loosen the cable strap for the lead wire on the comp case (front).
- (6) Disconnect the connectors CNF1 (WH), TH3 (WH), TH4 (WH), TH7/6 (RD), TH33 (YE), 63H (YE), 63HS (WH), 21S4 (GN), LEV-A (WH) and LEV-B (RD) from the controller circuit board.
 <Symbols on the board>
 - Fan motor (CNF1)
 - Thermistor <Liquid> (TH3)
 - Thermistor <Discharge> (TH4)
 - Thermistor <Ambient/ 2-Phase Pipe> (TH7/6)
 - Thermistor <Comp. Surface> (TH33)
 - High pressure switch (63H)
 - High pressure sensor (63HS)
 - 4-way valve (21S4)
 - LEV (LEV-A, LEV-B)
- (7) Disconnect the connectors ACL1 (RD), ACL2 (WH) and ACL3 (BK) on reactors in the separator.*1
- (8) Remove the cover panel (front) fixing screws (1 for front and 1 for right/ 5 × 12) to remove the cover panel (front).
- (9) Remove the comp case (top) fixing screws (2 for front and 1 for right/ 4 × 10) to remove the comp case (top).
- (10) Remove the comp case (front) fixing screws (4 for front and 2 for right/ 4 × 10) to remove the comp case (front).
- (11) Loosen the clamps, fasteners, band and cable straps for the lead wire in the electrical parts box and separator.
- (12) To disconnect the COMP lead wire, remove the terminal cover, then remove the terminal cover fixing screw of nut (1 for front/ M5).
- (13) Remove the electrical parts box fixing screws (2 for front/ 5 × 12), then slide the electrical parts box upward to remove it.
 (The electrical parts box is fixed to the side panel (R) with a hook on the right side, and to the separator duct with a hook on the left side.)

*1 For SW75Y model only

PHOTOS

Photo 1

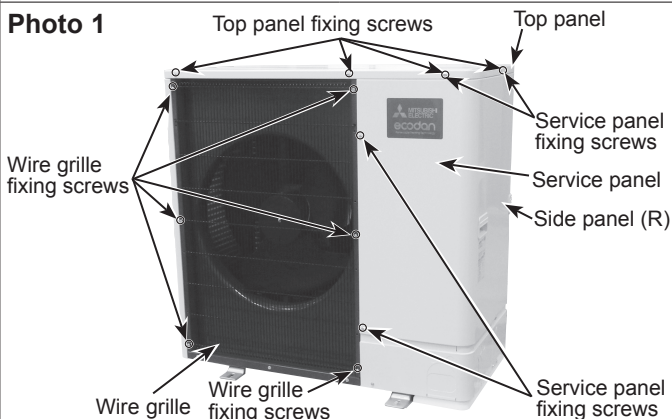

Photo 2-1

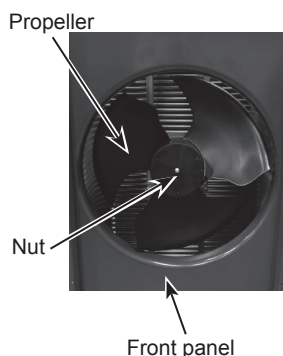

Photo 2-2

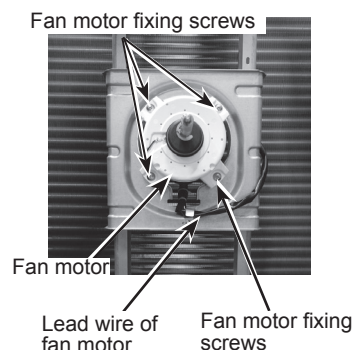

Photo 3-1

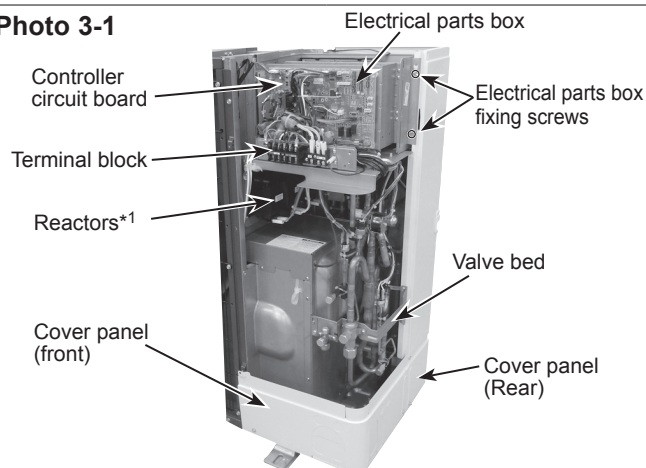
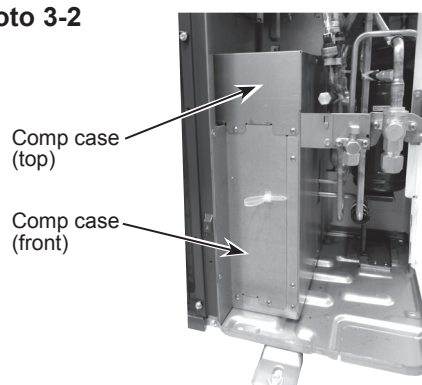

Photo 3-2



OPERATING PROCEDURE

4. Disassembling the electrical parts box (V model only)

- (1) Remove the electrical parts box. (See Photo 3-1)
- (2) Disconnect all the connectors on the controller circuit board.
- (3) To remove the controller circuit board, release it from the support.
- (4) Remove the cont base front fixing screws (3 for front/ 4 × 10) to remove the cont base front.
(The cont base front is fixed to the electrical parts box with a hook on the left side.)
- (5) Disconnect all the connectors on the power circuit board.
- (6) To remove the power circuit board, remove the power circuit board fixing screws (4 for front/ 3 × 12, 2 for front/ 4 × 18, and 1 for front 4 × 10), then release the board from the support.
- (7) Remove the reactor (DCL1, DCL2, DCL3) fixing screws (6 for rear/ 4 × 10) to remove the reactor, then disconnect the connectors on reactor.
- (8) Remove the thermistor <Heat sink> (TH8) fixing screws (2 for front/ 3 × 12) to remove the thermistor <Heat sink> (TH8).
- (9) To remove the heat sink, remove the heat sink duct fixing screws (6 for front/ 4 × 10), then slide the heat sink duct sideways to remove the heat sink.

Note 1: When reassembling the electrical parts box, make sure the wirings are correct.

PHOTOS

Photo 4-1

Cont base front

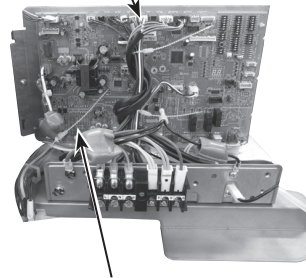

Controller circuit board

Photo 4-2

Power circuit board

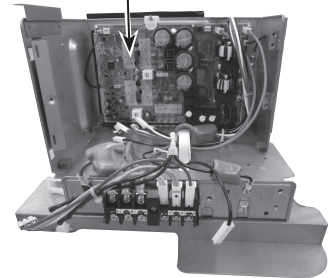

Photo 4-3

Reactors

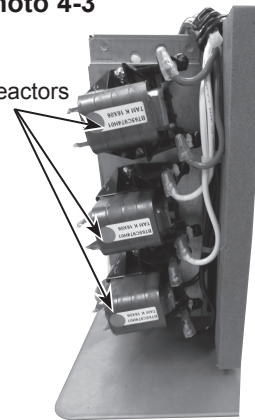
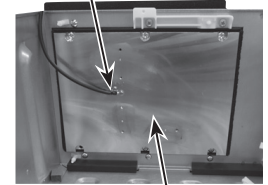

Photo 4-4

Thermistor <Heat sink> (TH8)



Heat sink

5. Disassembling the electrical parts box (Y model only)

- (1) Remove the electrical parts box. (See Photo 3-1)
- (2) Disconnect all the connectors on the controller circuit board.
- (3) To remove the controller circuit board, release it from the support.
- (4) Remove the cont base front fixing screws (3 for front/ 4 × 10) to remove the cont base front.
(The cont base front is fixed to the electrical parts box with a hook on the left side.)
- (5) Disconnect all the connectors on the noise filter circuit board.
- (6) To remove the noise filter circuit board, release it from the support.
- (7) Remove the cont base fixing screws (3 for front/ 4 × 10) to remove the cont base.
(The cont base is fixed to the electrical parts box with a hook on the left side.)
- (8) Disconnect all the connectors on the converter circuit board.
(The converter circuit board is attached to the rear side of the cont base.)
- (9) To remove the converter circuit board, release it from the support.
- (10) Disconnect all the connectors on the power circuit board.
- (11) To remove the power circuit board, remove the power circuit board fixing screws (4 for front/ 4 × 14), then release the board from the support.
- (12) Remove the thermistor <Heat sink> (TH8) fixing screws (2 for front/ 3 × 12) to remove the thermistor <Heat sink> (TH8).
- (13) Disconnect the connectors on reactor (ACL4), resistor (RS) and capacitor (CK) first, then remove the fixing screws of reactor, resistor and capacitor (4 for front/ 4 × 10), and remove reactor, resistor, resistor, and capacitor.
- (14) To remove the heat sink, remove the heat sink duct fixing screws (6 for front/ 4 × 18), then slide the heat sink duct sideways to remove the heat sink.

Note 1: When reassembling the electrical parts box, make sure the wirings are correct.

Photo 5-1

Cont base front

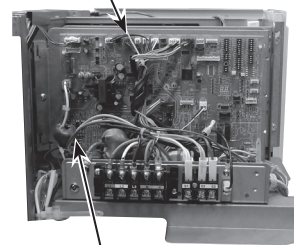

Controller circuit board

Photo 5-2

Noise filter circuit board

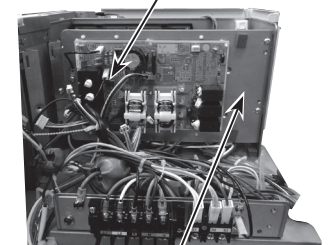

Cont base

Photo 5-3

Converter circuit board

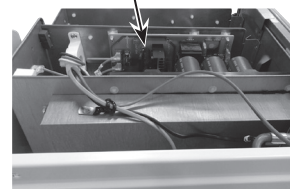
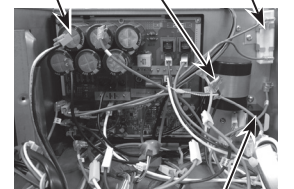

Photo 5-4

Power circuit board



Reactor

Photo 5-5

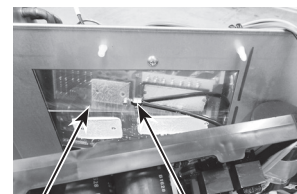

Heat sink

Thermistor <Heat sink> (TH8)

OPERATING PROCEDURE

6. Removing the thermistor <2-Phase Pipe> (TH6)

- (1) Remove the service panel. (See Photo 1)
- (2) Remove the top panel. (See Photo 1)
- (3) Disconnect the connector TH7/6 (RD) on the controller circuit board in the electrical parts box. (See Photo 3-1)
- (4) Loosen the fasteners and wire clips for the lead wire in the electrical parts box.
- (5) Loosen the clamp for the lead wire on the rear of electrical parts box.
- (6) Pull out the thermistor <2-phase pipe> (TH6) from thermistor clip.

Note 1: When replacing thermistor <2-phase pipe> (TH6), replace it together with thermistor <Ambient> (TH7) since they are combined together. Refer to procedure No.7 to remove the thermistor <Ambient> (TH7).

PHOTOS

Photo 6

Thermistor <2-Phase Pipe> (TH6)

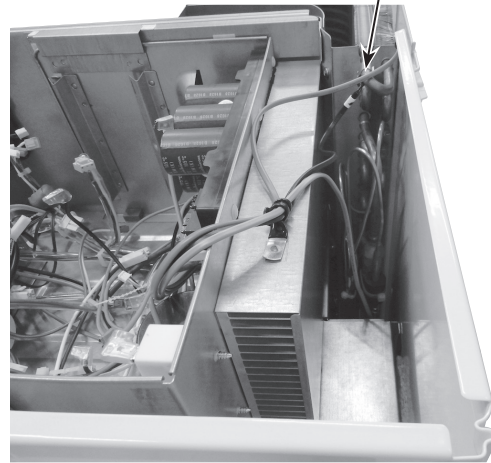

7. Removing the thermistor <Ambient> (TH7)

- (1) Remove the service panel. (See Photo 1)
- (2) Remove the top panel. (See Photo 1)
- (3) Disconnect the connector TH7/6 (RD) on the controller circuit board in the electrical parts box. (See Photo 3-1)
- (4) Loosen the fasteners and wire clips for the lead wire in the electrical parts box.
- (5) Loosen the clamps for the lead wire on rear of electrical parts box.
- (6) Remove the sensor holder fixing screw (1 for rear/ 5 × 12) to remove the sensor holder.
- (7) Pull out the thermistor <Ambient> (TH7) from sensor holder.

Note 1: When replacing thermistor <Ambient> (TH7), replace it together with thermistor <2-phase pipe> (TH6), since they are combined together. Refer to procedure No.6 to remove the thermistor <2-phase pipe>(TH6).

Photo 7

Thermistor <Ambient> (TH7) and sensor holder

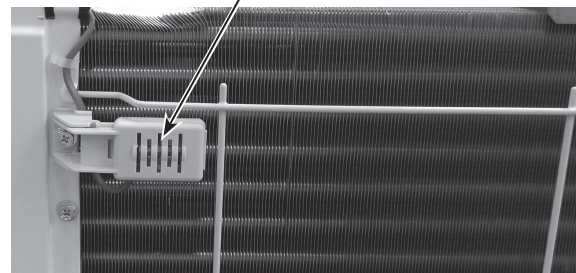

8. Removing the thermistor <Liquid> (TH3)

- (1) Remove the service panel. (See Photo 1)
- (2) Remove the top panel. (See Photo 1)
- (3) Remove the cover panel (front). (See Photo 3-1)
- (4) Remove the cover panel (rear) fixing screws (2 for rear and 2 for right/ 5 × 12) to remove the cover panel (rear). (See Photo 3-2)
- (5) Remove the valve bed fixing screws (2 for front/ 5 × 12) on the side panel (R). (See Photo 3-1)
- (6) Remove the electrical parts box fixing screws (2 for front/ 5 × 12). (See Photo 3-1)
- (7) Remove the sensor holder.
- (8) Remove the side panel (R) fixing screws (3 for rear/ 5 × 12) to remove the side panel (R). (See Photo 1)
- (9) Disconnect the connector TH3 (WH) on the controller circuit board in the electrical parts box. (See Photo 3-1)
- (10) Loosen the fasteners and wire clips for the lead wire in the electrical parts box.
- (11) Loosen the clamp for the lead wire on the rear of electrical parts box.
- (12) Pull out the thermistor <Liquid> (TH3) from thermistor clip.

Photo 8

Thermistor <Liquid> (TH3)

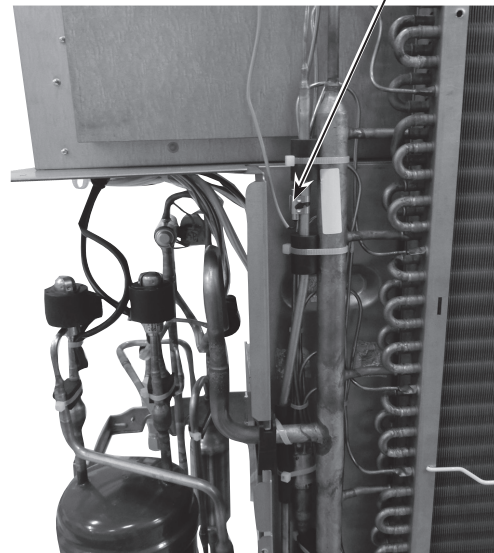

OPERATING PROCEDURE

9. Removing the thermistor <Discharge> (TH4) and thermistor <Comp. Surface> (TH33)

- (1) Remove the service panel. (See Photo 1)
- (2) Remove the top panel. (See Photo 1)
- (3) Remove the cover panel (front). (See Photo 3-1)
- (4) Remove the comp case (top). (See Photo 3-2)
- (5) Remove the comp case (front). (See Photo 3-2)
- (6) Disconnect the connectors TH4 (WH) and TH33(YE) on the controller circuit board in the electrical parts box. (See Photo 3-1)
- (7) Loosen the fasteners, wire clip and cable straps for the lead wire in the electrical parts box.
- (8) Loosen the bands for the lead wire.
- (9) Loosen the clamps for the lead wire in the separator.
- (10) Pull out the thermistor <Discharge> (TH4) from thermistor holder.
- (11) Pull out the thermistor <Comp. Surface> (TH33) from thermistor holder, then remove the terminal cover fixing screw of nut (1 for front/ M5).

10. Removing the 4-way valve coil (21S4), LEV coil (LEV-A, LEV-B) and lead wire for high pressure switch and high pressure sensor.

- (1) Remove the electrical parts box. (See Photo 3-1)
 - (2) Loosen the bands for the lead wire.
- [Removing the 4-way valve coil]
- (3) Remove the 4-way valve coil fixing screw (1 for front/ M5) to remove the 4-way valve coil.
 - (4) Slide the 4-way valve coil forward to remove it.
- [Removing the LEV coil]
- (3) Loosen the lead wires fixed to the pipes with bands.
 - (4) Slide the LEV coil upward to remove it.
- [Removing the lead wire for high pressure switch]
- (3) Disconnect the lead wire from the high pressure switch.
- [Removing the lead wire for high pressure sensor]
- (3) Disconnect the lead wire from the high pressure sensor.

11. Removing the 4-way valve, LEV (LEV-A, LEV-B), high pressure switch and high pressure sensor.

- (1) Remove the service panel. (See Photo 1)
 - (2) Recover refrigerant.
 - (3) Remove the electrical parts box. (See Photo 3-1)
 - (4) Remove the valve bed fixing screws (3 for front/ 5 × 12) and the ball valve and stop valve fixing screws (4 for front/ 5 × 16) to remove the valve bed.
 - (5) Remove the side panel (R). (See Photo 1)
- [Removing the 4-way valve]
- (6) Remove the 4-way valve coil.
 - (7) Remove the welded part of 4-way valve (4 positions) to remove the 4-way valve.
- [Removing the LEV]
- (6) Remove the LEV coil.
 - (7) Loosen the LEV fixed to the pipe with band and rubber mount.
 - (8) Remove the welded part of LEV (2 positions) to remove the LEV.
- [Removing the high pressure switch]
- (6) Disconnect the lead wire from the high pressure switch.
 - (7) Loosen the high pressure switch fixed to the pipe with band and rubber mount.
 - (8) Remove the welded part of high pressure switch (1 position) to remove the high pressure switch.
- [Removing the high pressure sensor]
- (6) Disconnect the lead wire from the high pressure sensor.
 - (7) Loosen the high pressure sensor fixed to the pipe with band and rubber mount.
 - (8) Remove the welded part of high pressure sensor (1 position) to remove the high pressure sensor.

Note 1: Recover refrigerant without spreading it in the air.

Note 2: When installing the following parts, cover it with a wet cloth to prevent it from heating as the temperature below, then braze the pipes so that the inside of pipes are not oxidized;

- 4-way valve, 120°C or more
- LEV, 120°C or more
- High pressure switch, 100°C or more
- High pressure sensor, 100°C or more

PHOTOS

Photo 9

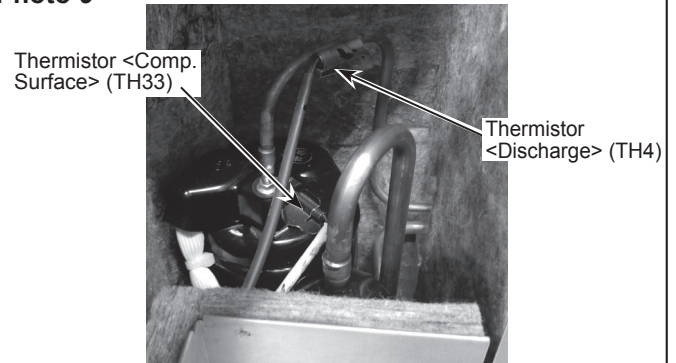
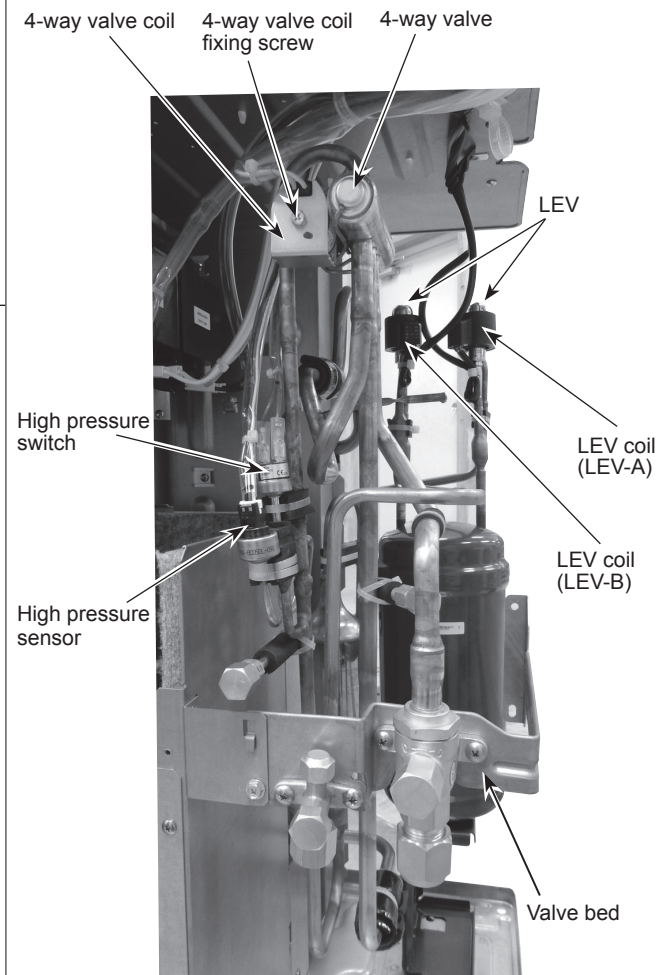

Photo 10



OPERATING PROCEDURE

12. Removing the compressor (MC)

- (1) Remove the service panel. (See Photo 1)
- (2) Recover refrigerant.
- (3) Remove the electrical parts box. (See Photo 3-1)
- (4) Remove the valve bed. (See Photo 3-1)
- (5) Remove the side panel (R). (See Photo 1)
- (6) Remove the thermistor <Liquid> (TH3), thermistor <2-Phase Pipe> (TH6), thermistor <Ambient> (TH7), thermistor <Discharge> (TH4) and thermistor <Comp. Surface> (TH33).
- (7) Remove the 4-way valve coil and LEV coil.
- (8) Disconnect the lead wire from the pressure switch and sensor.
- (9) Loosen the rubber mount fixed to the receiver pipes with band.
- (10) Remove the comp case (side) fixing screws (1 for front and 1 for right/ 4 x 10) to remove the comp case (side).
- (11) Remove the welded part (Joint part of the compressor, heat exchanger and receiver) of piping (6 positions), then slide the piping upward to remove it.
- (12) Remove the compressor fixing nuts (3 for top/ M6) to remove the compressor.

Note 1: Recover refrigerant without spreading it in the air.
Note 2: Tighten the nuts of compressor with a torque of $4 \pm 0.4 \text{ N}\cdot\text{m}$.

13. Removing the receiver

- (1) Remove the service panel. (See Photo 1)
- (2) Recover refrigerant.
- (3) Remove the piping.
- (4) Remove the receiver leg fixing screws (2 for top/ 4 x 10), then slide the receiver upward to remove it. (The receiver is fixed to the base with a hook on the bottom.)

Note 1: Recover refrigerant without spreading it in the air.

14. Removing the reactor (ACL1, ACL2, ACL3) (Y model only)

- (1) Remove the electrical parts box. (See Photo 3-1)
- (2) Remove the reactor assy fixing screws (8 for right/ 4 x 10), then slide the reactor assy upward to remove it.
- (3) Remove the reactor fixing screws (4 for front/ 4 x 10), to remove the reactor on the reactor assy.

Note 1: Pay extra attention when handling the reactor since it is very heavy (4.1 kg).

PHOTOS

Photo 11-1

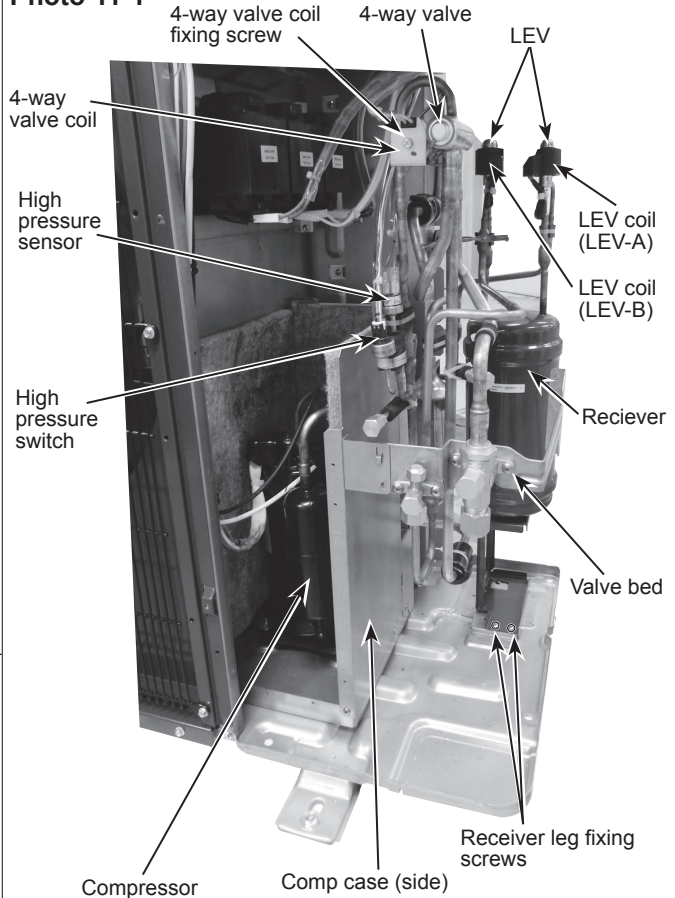

Photo 11-2

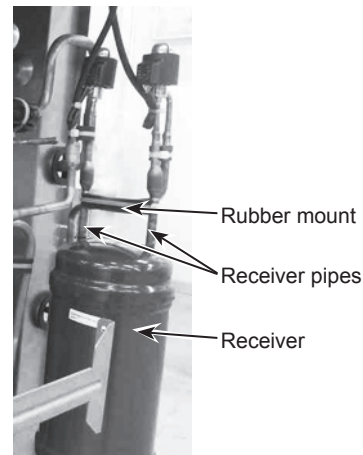
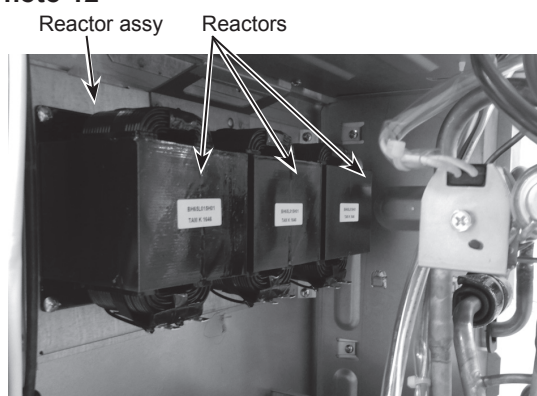

Photo 12





mitsubishi electric corporation

HEAD OFFICE : TOKYO BUILDING, 2-7-3, MARUNOUCHI, CHIYODA-KU, TOKYO 100-8310, JAPAN
