

TECHNICAL & SERVICE MANUAL

Models

PEFY-M20VMA(L)(2)-A	PEFY-M71VMA(L)(2)-A
PEFY-M25VMA(L)(2)-A	PEFY-M80VMA(L)(2)-A
PEFY-M32VMA(L)(2)-A	PEFY-M100VMA(L)(2)-A
PEFY-M40VMA(L)(2)-A	PEFY-M125VMA(L)(2)-A
PEFY-M50VMA(L)(2)-A	PEFY-M140VMA(L)-A
PEFY-M63VMA(L)(2)-A	

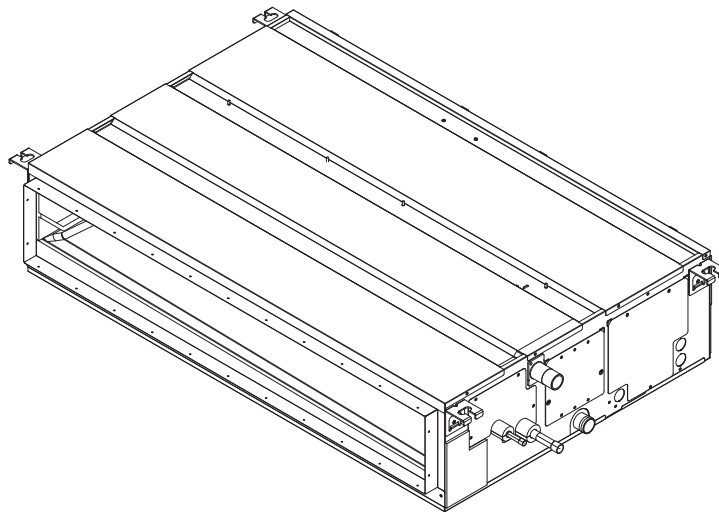





CITY MULTI

Safety Precautions

Read before installation and performing electrical work

- Thoroughly read the following safety precautions prior to installation.
- Observe these safety precautions for your safety.
- This equipment may have adverse effects on the equipment on the same power supply system.
- Contact the local power authority before connecting to the system.

MEANINGS OF SYMBOLS DISPLAYED ON THE UNIT

	WARNING (Risk of fire)	This mark is for R32 refrigerant only. Refrigerant type is written on nameplate of outdoor unit. In case that refrigerant type is R32, this unit uses a flammable refrigerant. If refrigerant leaks and comes in contact with fire or heating part, it will create harmful gas and there is risk of fire.
	Read the OPERATION MANUAL carefully before operation.	
	Service personnel are required to carefully read the OPERATION MANUAL and INSTALLATION MANUAL before operation.	
	Further information is available in the OPERATION MANUAL, INSTALLATION MANUAL, and the like.	

Symbols used in the text

WARNING

Describes precautions that should be observed to prevent danger of injury or death to the user.

CAUTION

Describes precautions that should be observed to prevent damage to the unit.

Symbols used in the illustrations



Indicates an action that must be avoided.



Indicates that important instructions must be followed.



Indicates a part which must be grounded.



Indicates that caution should be taken with rotating parts. (This symbol is displayed on the main unit label.) <Color: yellow>



Beware of electric shock (This symbol is displayed on the main unit label.) <Color: yellow>

WARNING

Carefully read the labels affixed to the main unit.

WARNING

• Ask the dealer or an authorized technician to install the air conditioner.

- Improper installation by the user may result in water leakage, electric shock, or fire.

• Install the air unit at a place that can withstand its weight.

- Inadequate strength may cause the unit to fall down, resulting in injuries.

• Install the indoor unit at least 2.5 m above floor or grade level.

- For appliances not accessible to the general public.

• Use the specified cables for wiring. Make the connections securely so that the outside force of the cable is not applied to the terminals.

- Inadequate connection and fastening may generate heat and cause a fire.

• Prepare for typhoons and other strong winds and earthquakes and install the unit at the specified place.

- Improper installation may cause the unit to topple and result in injury.

• Always use an air cleaner, humidifier, electric heater, and other accessories specified by Mitsubishi Electric.

- Ask an authorized technician to install the accessories. Improper installation by the user may result in water leakage, electric shock, or fire.

• Never repair the unit. If the air conditioner must be repaired, consult the dealer.

- If the unit is repaired improperly, water leakage, electric shock, or fire may result.

• Do not touch the heat exchanger fins.

- Improper handling may result in injury.

• When handling this product, always wear protective equipment.

EG: Gloves, full arm protection namely boiler suit, and safety glasses.

- Improper handling may result in injury.

• If refrigerant gas leaks during installation work, ventilate the room.

- If the refrigerant gas comes into contact with a flame, poisonous gases will be released.

• Install the air conditioner according to this Installation Manual.

- If the unit is installed improperly, water leakage, electric shock, or fire may result.

• Have all electric work done by a licensed electrician according to "Electric Facility Engineering Standard" and "Interior Wire Regulations" and the instructions given in this manual and always use a special circuit.

- If the power source capacity is inadequate or electric work is performed improperly, electric shock and fire may result.

• Keep the electric parts away from water (washing water etc.).

- It might result in electric shock, catching fire or smoke.

• Securely install the outdoor unit terminal cover (panel).

- If the terminal cover (panel) is not installed properly, dust or water may enter the outdoor unit and fire or electric shock may result.

• Do not use refrigerant other than the type indicated in the manuals provided with the unit and on the nameplate.

- Doing so may cause the unit or pipes to burst, or result in explosion or fire during use, during repair, or at the time of disposal of the unit.

- It may also be in violation of applicable laws.

- MITSUBISHI ELECTRIC CORPORATION cannot be held responsible for malfunctions or accidents resulting from the use of the wrong type of refrigerant.

• If the air conditioner is installed in a small room, measures must be taken to prevent the refrigerant concentration from exceeding the safety limit even if the refrigerant should leak.

- Consult the dealer regarding the appropriate measures to prevent the safety limit from being exceeded. Should the refrigerant leak and cause the safety limit to be exceeded, hazards due to lack of oxygen in the room could result.

• When moving and reinstalling the air conditioner, consult the dealer or an authorized technician.

- If the air conditioner is installed improperly, water leakage, electric shock, or fire may result.

• After completing installation work, make sure that refrigerant gas is not leaking.

- If the refrigerant gas leaks and is exposed to a fan heater, stove, oven, or other heat source, it may generate noxious gases.

• Do not reconstruct or change the settings of the protection devices.

- If the pressure switch, thermal switch, or other protection device is shorted and operated forcibly, or parts other than those specified by Mitsubishi Electric are used, fire or explosion may result.

• To dispose of this product, consult your dealer.

• Do not use a leak detection additive.

• If the supply cord is damaged, it must be replaced by the manufacturer, its service agent or similarly qualified persons in order to avoid a hazard.

• This appliance is not intended for use by persons (including children) with reduced physical, sensory or mental capabilities, or lack of experience and knowledge, unless they have been given supervision or instruction concerning use of the appliance by a person responsible for their safety.

• Children should be supervised to ensure that they do not play with the appliance.

• The installer and system specialist shall secure safety against leakage according to local regulation or standards.

- The instructions in this manual may be applicable if local regulation are not available.

- **Pay a special attention to the place, such as a basement, etc. where refrigeration gas can stay, since refrigeration is heavier than the air.**
- **This appliance is intended to be used by expert or trained users in shops, in light industry and on farms, or for commercial use by lay persons.**

Precautions for devices that use R32/R410A refrigerant

CAUTION

- **Do not use the existing refrigerant piping.**
 - The old refrigerant and refrigerator oil in the existing piping contains a large amount of chlorine which may cause the refrigerator oil of the new unit to deteriorate.
- **Use refrigerant piping made of C1220 (Cu-DHP) phosphorus deoxidized copper as specified in the JIS H3300 "Copper and copper alloy seamless pipes and tubes". In addition, be sure that the inner and outer surfaces of the pipes are clean and free of hazardous sulphur, oxides, dust/dirt, shaving particles, oils, moisture, or any other contaminant.**
 - Contaminants on the inside of the refrigerant piping may cause the refrigerant residual oil to deteriorate.
- **Store the piping to be used during installation indoors and keep both ends of the piping sealed until just before brazing. (Store elbows and other joints in a plastic bag.)**
 - If dust, dirt, or water enters the refrigerant cycle, deterioration of the oil and compressor trouble may result.
- **Use liquid refrigerant to fill the system.**
 - If gas refrigerant is used to seal the system, the composition of the refrigerant in the cylinder will change and performance may drop.
- **Do not use a refrigerant other than R32/R410A.**
 - If another refrigerant (R22, etc.) is used, the chlorine in the refrigerant may cause the refrigerator oil to deteriorate.
- **Use a vacuum pump with a reverse flow check valve.**
 - The vacuum pump oil may flow back into the refrigerant cycle and cause the refrigerator oil to deteriorate.
- **Do not use the following tools that are used with conventional refrigerants. (Gauge manifold, charge hose, gas leak detector, reverse flow check valve, refrigerant charge base, vacuum gauge, refrigerant recovery equipment)**
 - If the conventional refrigerant and refrigerator oil are mixed in the R32/R410A, the refrigerant may deteriorate.
 - If water is mixed in the R32/R410A, the refrigerator oil may deteriorate.
 - Since R32/R410A does not contain any chlorine, gas leak detectors for conventional refrigerants will not react to it.
- **Do not use a charging cylinder.**
 - Using a charging cylinder may cause the refrigerant to deteriorate.
- **Be especially careful when managing the tools.**
 - If dust, dirt, or water gets in the refrigerant cycle, the refrigerant may deteriorate.

Cautions for unit using R32 refrigerant

Basic work procedures are the same as those for conventional units using refrigerant R410A. However, pay careful attention to the following points.

- (1) Information on servicing
 - (1-1) Checks on the Area

Prior to beginning work on systems containing flammable refrigerants, safety checks are necessary to ensure that the risk of ignition is minimized.

For repair to the refrigerating systems, (1-3) to (1-7) shall be completed prior to conducting work on the systems.
 - (1-2) Work Procedure

Work shall be undertaken under a controlled procedure so as to minimize the risk of a flammable gas or vapor being present while the work is being performed.
 - (1-3) General Work Area

All maintenance staff and others working in the local area shall be instructed on the nature of work being carried out.

Work in confined spaces shall be avoided. The area around the workspace shall be sectioned off. Ensure that the conditions within the area have been made safe by control of flammable material.
 - (1-4) Checking for Presence of Refrigerant

The area shall be checked with an appropriate refrigerant detector prior to and during work, to ensure the technician is aware of potentially toxic or flammable atmospheres. Ensure that the leak detection equipment being used is suitable for use with all applicable refrigerants, i.e. non-sparking, adequately sealed or intrinsically safe.
 - (1-5) Presence of Fire Extinguisher

If any hot work is to be conducted on the refrigeration equipment or any associated parts, appropriate fire extinguishing equipment shall be available to hand.

Have a dry powder or CO2 fire extinguisher adjacent to the charging area.

- (1-6) No Ignition Sources

No person carrying out work in relation to a refrigeration system which involves exposing any pipe work shall use any sources of ignition in such a manner that it may lead to the risk of fire or explosion. All possible ignition sources, including cigarette smoking, should be kept sufficiently far away from the site of installation, repairing, removing and disposal, during which refrigerant can possibly be released to the surrounding space. Prior to work taking place, the area around the equipment is to be surveyed to make sure that there are no flammable hazards or ignition risks. "No Smoking" signs shall be displayed.
- (1-7) Ventilated Area

Ensure that the area is in the open or that it is adequately ventilated before breaking into the system or conducting any hot work. A degree of ventilation shall continue during the period that the work is carried out. The ventilation should safely disperse any released refrigerant and preferably expel it externally into the atmosphere.
- (1-8) Checks on the Refrigeration Equipment

Where electrical components are being changed, they shall be fit for the purpose and to the correct specification. At all times the manufacturer's maintenance and service guidelines shall be followed. If in doubt, consult the manufacturer's technical department for assistance.

The following checks shall be applied to installations using flammable refrigerants:

 - The charge size is in accordance with the room size within which the refrigerant containing parts are installed.
 - The ventilation machinery and outlets are operating adequately and are not obstructed.
 - Marking to the equipment continues to be visible and legible. Markings and signs that are illegible shall be corrected.
 - Refrigeration pipe or components are installed in a position where they are unlikely to be exposed to any substance which may corrode refrigerant containing components, unless the components are constructed of materials which are inherently resistant to being corroded or are suitably protected against being corroded.
- (1-9) Checks on Electrical Devices

Repair and maintenance to electrical components shall include initial safety checks and component inspection procedures.

If a fault exists that could compromise safety, then no electrical supply shall be connected to the circuit until it is satisfactorily dealt with. If the fault cannot be corrected immediately but it is necessary to continue operation, an adequate temporary solution shall be used. This shall be reported to the owner of the equipment so all parties are advised.

Initial safety checks shall include that:

 - capacitors are discharged: this shall be done in a safe manner to avoid possibility of sparking;
 - no live electrical components and wiring are exposed while charging, recovering or purging the system;
 - there is continuity of earth bonding
- (2) Repairs to Sealed Components
 - (2-1) During repairs to sealed components, all electrical supplies shall be disconnected from the equipment being worked upon prior to any removal of sealed covers, etc. If it is absolutely necessary to have an electrical supply to equipment during servicing, then a permanently operating form of leak detection shall be located at the most critical point to warn of a potentially hazardous situation.
 - (2-2) Particular attention shall be paid to the following to ensure that by working on electrical components, the casing is not altered in such a way that the level of protection is affected. This shall include damage to cables, excessive number of connections, terminals not made to original specification, damage to seals, incorrect fitting of glands, etc.

Ensure that the apparatus is mounted securely.

Ensure that seals or sealing materials have not degraded to the point that they no longer serve the purpose of preventing the ingress of flammable atmospheres.

Replacement parts shall be in accordance with the manufacturer's specifications.
- (3) Repair to intrinsically Safe Components

Do not apply any permanent inductive or capacitance loads to the circuit without ensuring that this will not exceed the permissible voltage and current permitted for the equipment in use.

Intrinsically safe components are the only types that can be worked on while live in the presence of a flammable atmosphere. The test apparatus shall be at the correct rating.

Replace components only with parts specified by the manufacturer. Other parts may result in the ignition of refrigerant in the atmosphere from a leak.
- (4) Cabling

Check that cabling will not be subject to wear, corrosion, excessive pressure, vibration, sharp edges or any other adverse environmental effects. The check shall also take into account the effects of aging or continual vibration from sources such as compressors or fans.
- (5) Detection of Flammable Refrigerants

Under no circumstances shall potential sources of ignition be used in the

- searching for or detection of refrigerant leaks.
A halide torch (or any other detector using a naked flame) shall not be used.
- (6) Leak Detection Methods
Electronic leak detectors may be used to detect refrigerant leaks but, in the case of flammable refrigerants, the sensitivity may not be adequate, or may need re-calibration. (Detection equipment shall be calibrated in a refrigerant-free area.)
Ensure that the detector is not a potential source of ignition and is suitable for the refrigerant used. Leak detection equipment shall be set at a percentage of the LFL of the refrigerant and shall be calibrated to the refrigerant employed, and the appropriate percentage of gas (25% maximum) is confirmed.
Leak detection fluids are suitable for use with most refrigerants but the use of detergents containing chlorine shall be avoided as the chlorine may react with the refrigerant and corrode the copper pipe-work.
If a leak is suspected, all naked flames shall be removed/extinguished. If a leakage of refrigerant is found which requires brazing, all of the refrigerant shall be recovered from the system, or isolated (by means of shut off valves) in a part of the system remote from the leak. For appliances containing flammable refrigerants, oxygen free nitrogen (OFN) shall then be purged through the system both before and during the brazing process.
- (7) Removal and Evacuation
When breaking into the refrigerant circuit to make repairs – or for any other purpose conventional procedures shall be used. However, for flammable refrigerants it is important that best practice is followed since flammability is a consideration. The following procedure shall be adhered to:
- remove refrigerant
 - purge the circuit with inert gas
 - evacuate
 - purge again with inert gas
 - open the circuit by cutting or brazing.
- The refrigerant charge shall be recovered into the correct recovery cylinders. For appliances containing flammable refrigerants, the system shall be “flushed” with OFN to render the unit safe. This process may need to be repeated several times.
Compressed air or oxygen shall not be used for purging refrigerant systems. For appliances containing flammable refrigerants, flushing shall be achieved by breaking the vacuum in the system with OFN and continuing to fill until the working pressure is achieved, then venting to atmosphere, and finally pulling down to a vacuum. This process shall be repeated until no refrigerant is within the system. When the final OFN charge is used, the system shall be vented down to atmospheric pressure to enable work to take place. This operation is absolutely vital if brazing operations on the pipe-work are to take place.
Ensure that the outlet for the vacuum pump is not close to any ignition sources and that ventilation is available.
- (8) Charging Procedures
In addition to conventional charging procedures, the following requirements shall be followed:
- Ensure that contamination of different refrigerants does not occur when using charging equipment. Hoses or lines shall be as short as possible to minimize the amount of refrigerant contained in them.
 - Cylinders shall be kept upright.
 - Ensure that the refrigeration system is earthed prior to charging the system with refrigerant.
 - Label the system when charging is complete (if not already).
 - Extreme care shall be taken not to overfill the refrigeration system.
- Prior to recharging the system, it shall be pressure-tested with the appropriate purging gas. The system shall be leak-tested on completion of charging but prior to commissioning. A follow up leak test shall be carried out prior to leaving the site.
- (9) Decommissioning
Before carrying out this procedure, it is essential that the technician is completely familiar with the equipment and all its detail. It is recommended good practice that all refrigerants are recovered safely. Prior to the task being carried out, an oil and refrigerant sample shall be taken in case analysis is required prior to re-use of reclaimed refrigerant. It is essential that electrical power is available before the task is commenced.
- a) Become familiar with the equipment and its operation.
 - b) Isolate system electrically.
 - c) Before attempting the procedure, ensure that:
 - mechanical handling equipment is available, if required, for handling refrigerant cylinders;
 - all personal protective equipment is available and being used correctly;
 - the recovery process is supervised at all times by a competent person;
 - recovery equipment and cylinders conform to the appropriate standards.
 - d) Pump down refrigerant system, if possible.
 - e) If a vacuum is not possible, make a manifold so that refrigerant can be removed from various parts of the system.
- f) Make sure that cylinder is situated on the scales before recovery takes place.
 - g) Start the recovery machine and operate in accordance with manufacturer’s instructions.
 - h) Do not overfill cylinders. (No more than 80 % volume liquid charge).
 - i) Do not exceed the maximum working pressure of the cylinder, even temporarily.
 - j) When the cylinders have been filled correctly and the process completed, make sure that the cylinders and the equipment are removed from site promptly and all isolation valves on the equipment are closed off.
 - k) Recovered refrigerant shall not be charged into another refrigeration system unless it has been cleaned and checked.
- (10) Labelling
Equipment shall be labelled stating that it has been de-commissioned and emptied of refrigerant. The label shall be dated and signed. For appliances containing flammable refrigerants, ensure that there are labels on the equipment stating the equipment contains flammable refrigerant.
- (11) Recovery
When removing refrigerant from a system, either for servicing or decommissioning, it is recommended good practice that all refrigerants are removed safely. When transferring refrigerant into cylinders, ensure that only appropriate refrigerant recovery cylinders are employed. Ensure that the correct number of cylinders for holding the total system charge are available. All cylinders to be used are designated for the recovered refrigerant and labelled for that refrigerant (i.e. special cylinders for the recovery of refrigerant). Cylinders shall be complete with pressure-relief valve and associated shut-off valves in good working order. Empty recovery cylinders are evacuated and, if possible, cooled before recovery occurs.
The recovery equipment shall be in good working order with a set of instructions concerning the equipment that is at hand and shall be suitable for the recovery of all appropriate refrigerants including, when applicable, flammable refrigerants. In addition, a set of calibrated weighing scales shall be available and in good working order. Hoses shall be complete with leak-free disconnect couplings and in good condition. Before using the recovery machine, check that it is in satisfactory working order, has been properly maintained and that any associated electrical components are sealed to prevent ignition in the event of a refrigerant release. Consult manufacturer if in doubt.
The recovered refrigerant shall be returned to the refrigerant supplier in the correct recovery cylinder, and the relevant waste transfer note arranged. Do not mix refrigerants in recovery units and especially not in cylinders. If compressors or compressor oils are to be removed, ensure that they have been evacuated to an acceptable level to make certain that flammable refrigerant does not remain within the lubricant. The evacuation process shall be carried out prior to returning the compressor to the suppliers. Only electric heating to the compressor body shall be employed to accelerate this process. When oil is drained from a system, it shall be carried out safely.



CONTENTS

I Features

[1] Features.....	1
-------------------	---

II Components and Functions

[1] Components and Functions.....	2
-----------------------------------	---

III Specifications

[1] Specifications.....	5
1.Specifications.....	5
2.Electrical component specifications.....	11

IV Outlines and Dimensions

[1] Outlines and Dimensions.....	14
[2] Service Space.....	17

V Wiring Diagram

[1] Wiring Diagram.....	20
-------------------------	----

VI Refrigerant System Diagram

[1] Refrigerant system diagram.....	22
-------------------------------------	----

VII Troubleshooting

[1] Troubleshooting.....	23
1.Check methods.....	23
2.DC fan motor (fan motor/indoor control board).....	27
3.Address switch setting.....	28
4.Voltage test points on the control board.....	29
5.Dipswitch setting (Factory setting).....	30

VIII Disassembly Procedure

[1] Disassembly Procedure.....	33
1.Control box.....	33
2.Thermistor (Intake air).....	34
3.Drain pump.....	34
4.Drainpan.....	35
5.Thermistor (Gas pipe) (Liquid pipe).....	36
6.Fan and fan motor.....	37
7.Heat exchanger.....	38



[1] Features

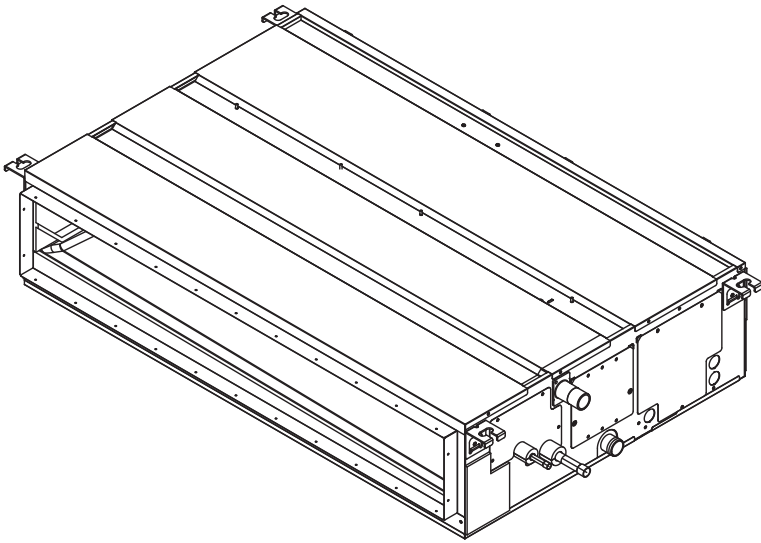

Model	Cooling capacity/Heating capacity
	kW
PEFY-M20VMA(L)(2)-A	2.2/2.5
PEFY-M25VMA(L)(2)-A	2.8/3.2
PEFY-M32VMA(L)(2)-A	3.6/4.0
PEFY-M40VMA(L)(2)-A	4.5/5.0
PEFY-M50VMA(L)(2)-A	5.6/6.3
PEFY-M63VMA(L)(2)-A	7.1/8.0
PEFY-M71VMA(L)(2)-A	8.0/9.0
PEFY-M80VMA(L)(2)-A	9.0/10.0
PEFY-M100VMA(L)(2)-A	11.2/12.5
PEFY-M125VMA(L)(2)-A	14.0/16.0
PEFY-M140VMA(L)-A	16.0/18.0

[1] Components and Functions

1. Indoor (Main) Unit

(1) In case of rear inlet

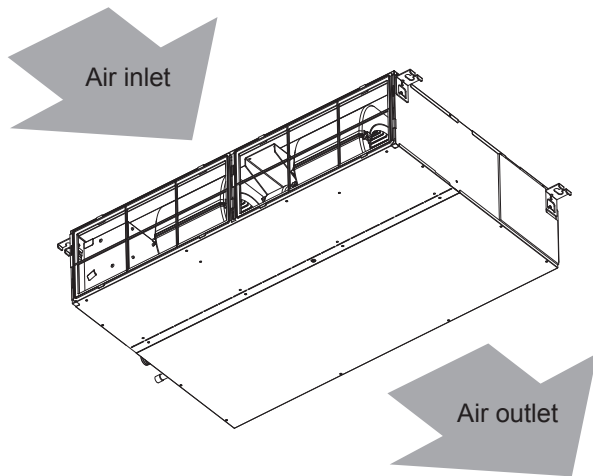

(2) In case of bottom inlet

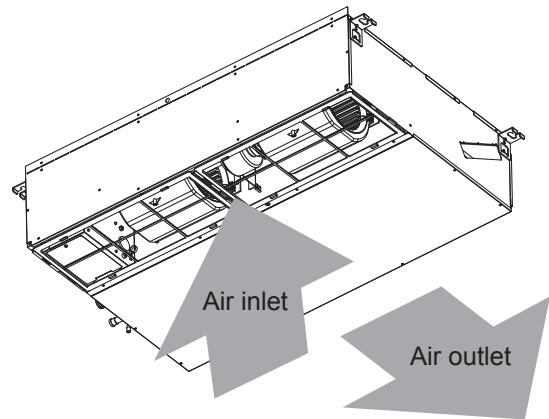

2. Remote Controller

Once the operation mode is selected, the unit will remain in the selected mode until changed.

(1) Remote Controller Buttons

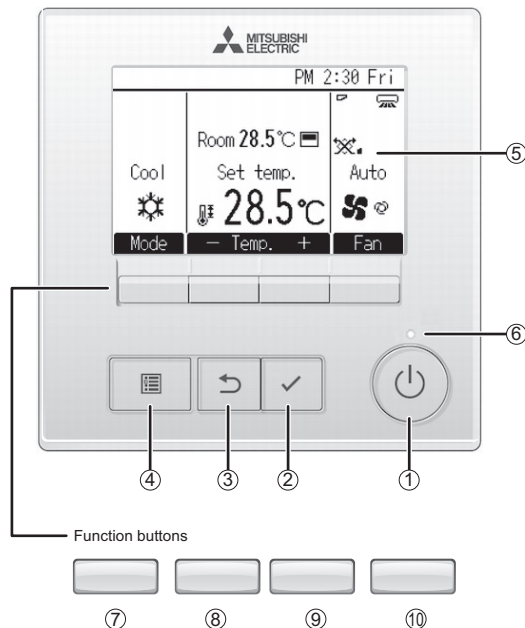

① [ON/OFF] button

Press to turn ON/OFF the indoor unit.

② [SELECT] button

Press to save the setting.

③ [RETURN] button

Press to return to the previous screen.

④ [MENU] button

Press to bring up the Main menu.

⑤ Backlit LCD

Operation settings will appear.
When the backlight is off, pressing any button turns the backlight on and it will stay lit for a certain period of time depending on the screen.

When the backlight is off, pressing any button turns the backlight on and does not perform its function. (except for the [ON/OFF] button)

⑥ ON/OFF lamp

This lamp lights up in green while the unit is in operation. It blinks while the remote controller is starting up or when there is an error.

The functions of the function buttons change depending on the screen. Refer to the button function guide that appears at the bottom of the LCD for the functions they serve on a given screen. When the system is centrally controlled, the button function guide that corresponds to the locked button will not appear.

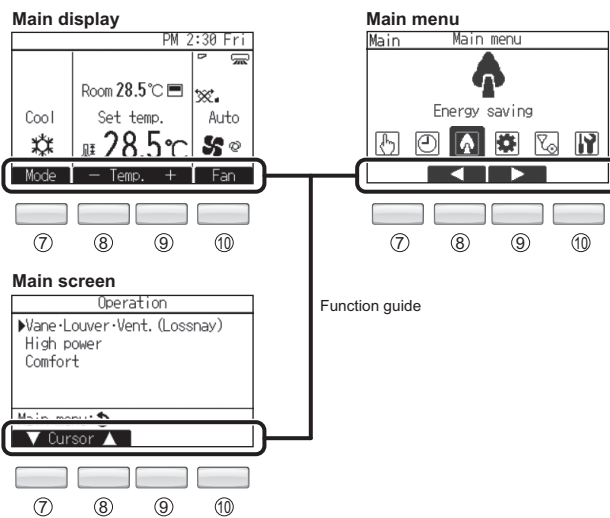

⑦ Function button [F1]

Main display: Press to change the operation mode.
Menu screen: The button function varies with the screen.

⑧ Function button [F2]

Main display: Press to decrease temperature.
Main menu: Press to move the cursor left.
Menu screen: The button function varies with the screen.

⑨ Function button [F3]

Main display: Press to increase temperature.
Main menu: Press to move the cursor right.
Menu screen: The button function varies with the screen.

⑩ Function button [F4]

Main display: Press to change the fan speed.
Menu screen: The button function varies with the screen.

(2) Remote Controller Display

The main display can be displayed in two different modes: "Full" and "Basic." The factory setting is "Full." To switch to the "Basic" mode, change the setting on the Main display setting.

Full mode

* All icons are displayed for explanation.

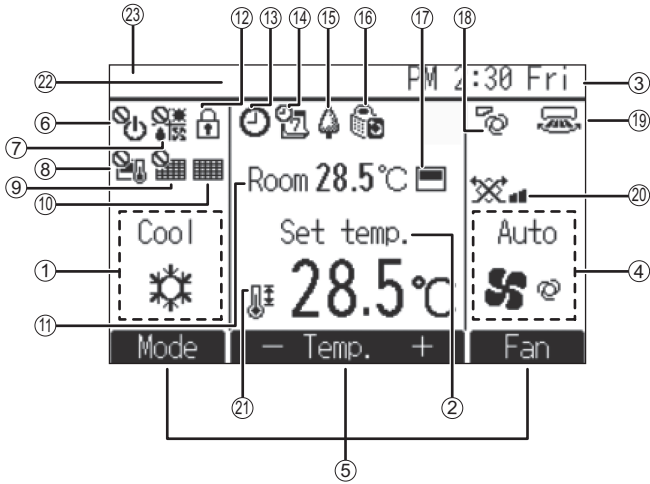

Basic mode

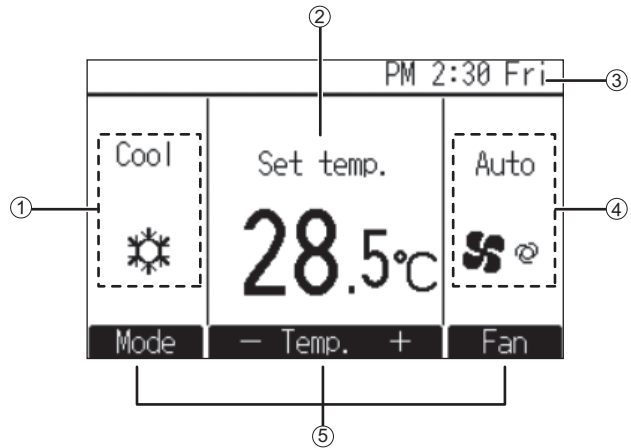

- ① Operation mode**
Indoor unit operation mode appears here.
- ② Set temperature**
Set temperature appears here.
- ③ Clock**
Current time appears here.
- ④ Fan speed**
Fan speed setting appears here.
- ⑤ Button function guide**
Functions of the corresponding buttons appear here.
- ⑥**
Appears when the ON/OFF operation is centrally controlled.
- ⑦**
Appears when the operation mode is centrally controlled.
- ⑧**
Appears when the set temperature is centrally controlled.
- ⑨**
Appears when the filter reset function is centrally controlled.
- ⑩**
Indicates when filter needs maintenance.
- ⑪ Room temperature**
Current room temperature appears here.
- ⑫**
Appears when the buttons are locked.
- ⑬**
Appears when the On/Off timer, Night setback, or Auto-off timer function is enabled.
Appears when the timer is disabled by the centralized control system.
- ⑭**
Appears when the Weekly timer is enabled.

- ⑮**
Appears while the units are operated in the energy-save mode. (Will not appear on some models of indoor units)
- ⑯**
Appears while the outdoor units are operated in the silent mode.
- ⑰**
Appears when the built-in thermistor on the remote controller is activated to monitor the room temperature (⑪).
Appears when the thermistor on the indoor unit is activated to monitor the room temperature.
- ⑱**
Indicates the vane setting.
- ⑲**
Indicates the louver setting.
- ⑳**
Indicates the ventilation setting.
- ㉑**
Appears when the set temperature range is restricted.
- ㉒ Centrally controlled**
Appears for a certain period of time when a centrally-controlled item is operated.
- ㉓ Preliminary error display**
An error code appears during the preliminary error.

Most settings (except ON/OFF, mode, fan speed, temperature) can be made from the Main menu.

[1] Specifications

1. Specifications

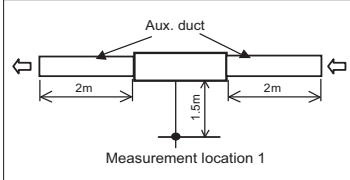
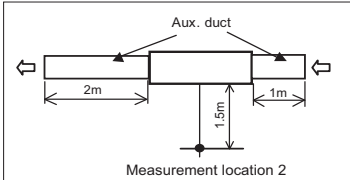
Model			PEFY-M20VMA(L)-A	PEFY-M25VMA(L)-A	PEFY-M32VMA(L)-A	PEFY-M40VMA(L)-A
Power supply	Voltage	V	1-phase 220-230-240			
	Frequency	Hz	50			
Cooling capacity *1		kW	2.2	2.8	3.6	4.5
Heating capacity *1		kW	2.5	3.2	4.0	5.0
Power consumption *2	Cooling	kW	0.032(0.030)		0.044(0.042)	0.047(0.045)
	Heating	kW	0.030		0.042	0.045
Current consumption	Cooling	A	0.26		0.36	0.39
	Heating	A	0.26		0.36	0.39
External finish			Galvanized			
Dimensions	Height	mm	250			
	Width	mm	700			900
	Depth	mm	732			
Net weight *2		kg	21(20)			25(24)
Heat exchanger			Cross fin (Aluminium fin and copper tube)			
Fan	Type		Sirocco fan x 1			Sirocco fan x 2
	Airflow rate (Low-Mid-High)	m ³ /min	6.0-7.5-8.5		7.5-9.0-10.5	10.0-12.0-14.0
	External static pressure	Pa	35/50/70/100/150			
Motor	Output	kW	0.085			0.121
Air filter			PP Honeycomb fabric (washable)			
Refrigerant pipe dimensions	Gas (Brazed connection)	mm[in.]	ø12.7[ø1/2]			
	Liquid (Brazed connection)	mm[in.]	ø6.35[ø1/4]			
Drain pipe dimensions		mm[in.]	O.D. 32[1-1/4]			
Operating noise(Low-Mid-High)  * Measured in anechoic room.  * Measured in anechoic room.	35Pa	dB (A)	18-22-24		20-24-27	20-25-28
	50Pa		20-23-26		21-25-30	21-28-30
	70Pa		19-24-27		22-27-31	24-28-32
	100Pa		21-27-30		24-29-32	26-30-34
	150Pa		25-31-35		28-32-36	29-34-38
	35Pa		21-25-27		23-27-30	23-28-31
	50Pa		23-26-29		24-28-33	24-31-33
	70Pa		22-27-30		25-30-34	27-31-35
	100Pa		24-30-33		27-32-35	29-33-37
	150Pa		28-34-38		31-35-39	32-37-41

*1 <Cooling> Indoor temperature: 27°CDB/19°CWB (81°FDB/66°FWB) Outdoor temperature: 35°CDB (95°FDB)

<Heating> Indoor temperature: 20°CDB (68°FWB) Outdoor temperature: 7°CDB/6°CWB (45°FDB/43°FWB)

*2 Figures in the parentheses indicate drainpump-less Model (L).

[III Specifications]

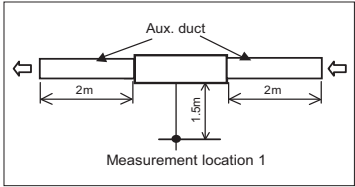
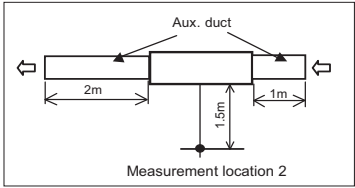
Model			PEFY-M50VMA(L)-A	PEFY-M63VMA(L)-A	PEFY-M71VMA(L)-A	PEFY-M80VMA(L)-A
Power supply	Voltage	V	1-phase 220-230-240			
	Frequency	Hz	50			
Cooling capacity *1		kW	5.6	7.1	8.0	9.0
Heating capacity *1		kW	6.3	8.0	9.0	10.0
Power consumption *2	Cooling	kW	0.066(0.064)	0.087(0.085)	0.080(0.078)	
	Heating	kW	0.064	0.085	0.078	
Current consumption	Cooling	A	0.53	0.69	0.60	
	Heating	A	0.53	0.69	0.60	
External finish			Galvanized			
Dimensions	Height	mm	250			
	Width	mm	900		1100	
	Depth	mm	732			
Net weight *2		kg	25(24)	27(26)	30(29)	
Heat exchanger			Cross fin (Aluminium fin and copper tube)			
Fan	Type		Sirocco fan x 2			
	Airflow rate (Low-Mid-High)	m ³ /min	12.0-14.5-17.0	13.5-16.0-19.0	14.5-18.0-21.0	
	External static pressure	Pa	35/50/70/100/150		40/50/70/100/150	
Motor	Output	kW	0.121			
Air filter			PP Honeycomb fabric (washable)			
Refrigerant pipe dimensions	Gas (Brazed connection)	mm[in.]	ø12.7[ø1/2]	ø15.88[ø5/8]		
	Liquid (Brazed connection)	mm[in.]	ø6.35[ø1/4]	ø9.52[ø3/8]		
Drain pipe dimensions		mm[in.]	O.D. 32[1-1/4]			
Operating noise(Low-Mid-High)		35Pa / 40Pa	dB (A)	21-28-31	24-28-32	22-28-31
 <p>Measurement location 1</p> <p>* Measured in anechoic room.</p>		50Pa		25-29-33	27-30-35	26-29-32
		70Pa		25-30-35	27-32-36	26-30-34
		100Pa		28-33-37	29-34-38	27-32-36
		150Pa		30-35-39	32-37-41	30-36-39
		35Pa / 40Pa		24-31-34	27-31-35	25-31-34
 <p>Measurement location 2</p> <p>* Measured in anechoic room.</p>		50Pa		28-32-36	30-33-38	29-32-35
		70Pa		28-33-38	30-35-39	29-33-37
		100Pa		31-36-40	32-37-41	30-35-39
		150Pa		33-38-42	35-40-44	33-39-42
		35Pa / 40Pa		24-31-34	27-31-35	25-31-34

*1 <Cooling> Indoor temperature: 27°CDB/19°CWB (81°FDB/66°FWB) Outdoor temperature: 35°CDB (95°FDB)
 <Heating> Indoor temperature: 20°CDB (68°FWB) Outdoor temperature: 7°CDB/6°CWB (45°FDB/43°FWB)

*2 Figures in the parentheses indicate drainpump-less Model (L).

[III Specifications]

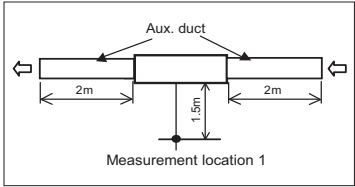
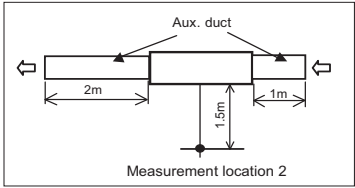
Model			PEFY-M100VMA(L)-A	PEFY-M125VMA(L)-A	PEFY-M140VMA(L)-A	
Power supply	Voltage	V	1-phase 220-230-240			
	Frequency	Hz	50			
Cooling capacity *1		kW	11.2	14.0	16.0	
Heating capacity *1		kW	12.5	16.0	18.0	
Power consumption *2	Cooling	kW	0.142(0.140)	0.199(0.197)	0.208(0.206)	
	Heating	kW	0.140	0.197	0.206	
Current consumption	Cooling	A	1.01	1.29	1.40	
	Heating	A	1.01	1.29	1.40	
External finish			Galvanized			
Dimensions	Height	mm	250			
	Width	mm	1400	1600		
	Depth	mm	732			
Net weight *2		kg	37(36)	38(37)	42(41)	
Heat exchanger			Cross fin (Aluminium fin and copper tube)			
Fan	Type	Sirocco fan x 3				
	Airflow rate (Low-Mid-High)	m ³ /min	23.0-28.0-32.0	28.0-34.0-37.0	29.5-35.5-40.0	
	External static pressure	Pa	40/50/70/100/150			
Motor	Output	kW	0.300			
Air filter			PP Honeycomb fabric (washable)			
Refrigerant pipe dimensions	Gas (Brazed connection)	mm[in.]	ø15.88[ø5/8]			
	Liquid (Brazed connection)	mm[in.]	ø9.52[ø3/8]			
Drain pipe dimensions		mm[in.]	O.D. 32[1-1/4]			
Operating noise(Low-Mid-High)		40Pa	dB (A)	27-32-35	30-34-36	30-34-36
 <p>Measurement location 1</p> <p>* Measured in anechoic room.</p>		50Pa		28-33-36	31-35-37	30-34-37
		70Pa		30-35-38	31-36-38	31-35-37
		100Pa		32-37-40	32-37-39	32-36-39
		150Pa		34-40-43	35-40-42	34-38-42
		40Pa		30-35-38	33-37-39	33-37-39
 <p>Measurement location 2</p> <p>* Measured in anechoic room.</p>		50Pa		31-36-39	34-38-40	33-37-40
		70Pa		33-38-41	34-39-41	34-38-40
		100Pa		35-40-43	35-40-42	35-39-42
		150Pa		37-43-46	38-43-45	37-41-45

*1 <Cooling> Indoor temperature: 27°CDB/19°CWB (81°FDB/66°FWB) Outdoor temperature: 35°CDB (95°FDB)
 <Heating> Indoor temperature: 20°CDB (68°FWB) Outdoor temperature: 7°CDB/6°CWB (45°FDB/43°FWB)

*2 Figures in the parentheses indicate drainpump-less Model (L).

[III Specifications]

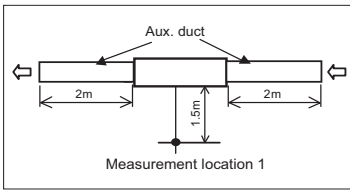
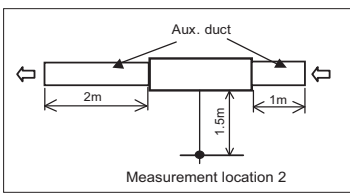
Model			PEFY-M20VMA2-A	PEFY-M25VMA2-A	PEFY-M32VMA2-A	PEFY-M40VMA2-A	
Power supply	Voltage	V	1-phase 220-230-240				
	Frequency	Hz	50				
Cooling capacity *1		kW	7.1			8.0	
Heating capacity *1		kW	8.0			9.0	
Power consumption *2	Cooling	kW	0.087(0.085)			0.080(0.078)	
	Heating	kW	0.085			0.078	
Current consumption	Cooling	A	0.69			0.60	
	Heating	A	0.69			0.60	
External finish			Galvanized				
Dimensions	Height	mm	250				
	Width	mm	900		1100		
	Depth	mm	732				
Net weight *2		kg	27(26)			30(29)	
Heat exchanger			Cross fin (Aluminium fin and copper tube)				
Fan	Type		Sirocco fan x 2				
	Airflow rate (Low-Mid-High)	m ³ /min	13.5-16.0-19.0			14.5-18.0-21.0	
	External static pressure	Pa	35/50/70/100/150			40/50/70/100/150	
Motor	Output	kW	0.121				
Air filter			PP Honeycomb fabric (washable)				
Refrigerant pipe dimensions	Gas (Brazed connection)	mm[in.]	ø12.7[ø1/2]				
	Liquid (Brazed connection)	mm[in.]	ø6.35[ø1/4]				
Drain pipe dimensions		mm[in.]	O.D. 32[1-1/4]				
Operating noise(Low-Mid-High)	 <p>Measurement location 1</p> <p>* Measured in anechoic room.</p>		35Pa	dB (A)		24-28-32	22-28-31
			50Pa			27-30-35	26-29-32
			70Pa			27-32-36	26-30-34
			100Pa			29-34-38	27-32-36
			150Pa			32-37-41	30-36-39
			 <p>Measurement location 2</p> <p>* Measured in anechoic room.</p>		35Pa		
	50Pa				30-33-38	29-32-35	
	70Pa				30-35-39	29-33-37	
	100Pa				32-37-41	30-35-39	
	150Pa				35-40-44	33-39-42	

*1 <Cooling> Indoor temperature: 27°CDB/19°CWB (81°FDB/66°FWB) Outdoor temperature: 35°CDB (95°FDB)

<Heating> Indoor temperature: 20°CDB (68°FWB) Outdoor temperature: 7°CDB/6°CWB (45°FDB/43°FWB)

*2 Figures in the parentheses indicate drainpump-less Model (L).

[III Specifications]

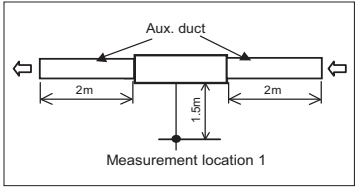
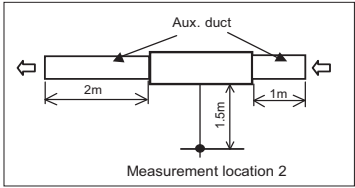
Model			PEFY-M50VMA2-A	PEFY-M63VMA2-A	PEFY-M71VMA2-A	PEFY-M80VMA2-A
Power supply	Voltage	V	1-phase 220-230-240			
	Frequency	Hz	50			
Cooling capacity *1		kW	16.0			
Heating capacity *1		kW	18.0			
Power consumption *2	Cooling	kW	0.208(0.206)			
	Heating	kW	0.206			
Current consumption	Cooling	A	1.40			
	Heating	A	1.40			
External finish			Galvanized			
Dimensions	Height	mm	250			
	Width	mm	1600			
	Depth	mm	732			
Net weight *2		kg	42(41)			
Heat exchanger			Cross fin (Aluminium fin and copper tube)			
Fan	Type		Sirocco fan x 3			
	Airflow rate (Low-Mid-High)	m ³ /min	29.5-35.5-40.0			
	External static pressure	Pa	40/50/70/100/150			
Motor	Output	kW	0.300			
Air filter			PP Honeycomb fabric (washable)			
Refrigerant pipe dimensions	Gas (Brazed connection)	mm[in.]	ø12.7[ø1/2]	ø15.88[ø5/8]		
	Liquid (Brazed connection)	mm[in.]	ø6.35[ø1/4]	ø9.52[ø3/8]		
Drain pipe dimensions		mm[in.]	O.D. 32[1-1/4]			
Operating noise(Low-Mid-High)		35Pa / 40Pa	dB (A)	30-34-36		
 <p>Measurement location 1</p> <p>* Measured in anechoic room.</p>		50Pa		30-34-37		
		70Pa		31-35-37		
		100Pa		32-36-39		
		150Pa		34-38-42		
		 <p>Measurement location 2</p> <p>* Measured in anechoic room.</p>		35Pa / 40Pa	33-37-39	
50Pa	33-37-40					
70Pa	34-38-40					
100Pa	35-39-42					
150Pa	37-41-45					

*1 <Cooling> Indoor temperature: 27°CDB/19°CWB (81°FDB/66°FWB) Outdoor temperature: 35°CDB (95°FDB)
 <Heating> Indoor temperature: 20°CDB (68°FWB) Outdoor temperature: 7°CDB/6°CWB (45°FDB/43°FWB)

*2 Figures in the parentheses indicate drainpump-less Model (L).

[III Specifications]

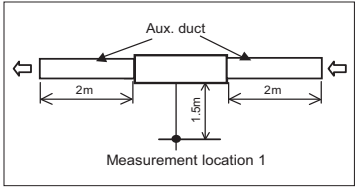
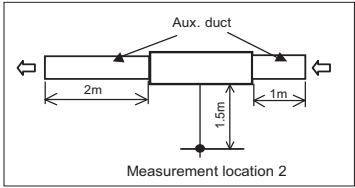
Model			PEFY-M100VMA2-A	PEFY-M125VMA2-A
Power supply	Voltage	V	1-phase 220-230-240	
	Frequency	Hz	50	
Cooling capacity *1		kW	16.0	
Heating capacity *1		kW	18.0	
Power consumption *2	Cooling	kW	0.208(0.206)	
	Heating	kW	0.206	
Current consumption	Cooling	A	1.40	
	Heating	A	1.40	
External finish			Galvanized	
Dimensions	Height	mm	250	
	Width	mm	1600	
	Depth	mm	732	
Net weight *2		kg	42(41)	
Heat exchanger			Cross fin (Aluminium fin and copper tube)	
Fan	Type		Sirocco fan x 3	
	Airflow rate (Low-Mid-High)	m ³ /min	29.5-35.5-40.0	
	External static pressure	Pa	40/50/70/100/150	
Motor	Output	kW	0.300	
Air filter			PP Honeycomb fabric (washable)	
Refrigerant pipe dimensions	Gas (Brazed connection)	mm[in.]	ø15.88[ø5/8]	
	Liquid (Brazed connection)	mm[in.]	ø9.52[ø3/8]	
Drain pipe dimensions		mm[in.]	O.D. 32[1-1/4]	
Operating noise(Low-Mid-High)  * Measured in anechoic room.  * Measured in anechoic room.	40Pa	dB (A)	30-34-36	
	50Pa		30-34-37	
	70Pa		31-35-37	
	100Pa		32-36-39	
	150Pa		34-38-42	
	40Pa		33-37-39	
	50Pa		33-37-40	
	70Pa		34-38-40	
	100Pa		35-39-42	
	150Pa		37-41-45	

*1 <Cooling> Indoor temperature: 27°CDB/19°CWB (81°FDB/66°FWB) Outdoor temperature: 35°CDB (95°FDB)
 <Heating> Indoor temperature: 20°CDB (68°FWB) Outdoor temperature: 7°CDB/6°CWB (45°FDB/43°FWB)

*2 Figures in the parentheses indicate drainpump-less Model (L).

2. Electrical component specifications

Component	Sym- bol	PEFY- M20VMA(L)-A	PEFY- M25VMA(L)-A	PEFY- M32VMA(L)-A
Room temperature thermistor	TH21	Resistance 0°C/15kΩ, 10°C/9.6kΩ, 20°C/6.3kΩ, 25°C/5.4kΩ, 30°C/4.3kΩ, 40°C/3.0kΩ		
Liquid pipe thermistor	TH22	Resistance 0°C/15kΩ, 10°C/9.6kΩ, 20°C/6.3kΩ, 25°C/5.4kΩ, 30°C/4.3kΩ, 40°C/3.0kΩ		
Gas pipe thermistor	TH23	Resistance 0°C/15kΩ, 10°C/9.6kΩ, 20°C/6.3kΩ, 25°C/5.4kΩ, 30°C/4.3kΩ, 40°C/3.0kΩ		
Fuse	F01	AC250V 6.3A		
	F02	DC400V 3A		
Fan motor		8-pole, Output 85W ZWB278D51A		
Linear expansion valve	LEV	12VDC Stepping motor (0~2000 pulse)		
Power supply terminal block	TB2	(L, N, ⊕) 250V 20A		
Transmission terminal block	TB5 TB15	(1, 2) 250V 15A, (M1, M2, S) 250V 20A		
Drain pump		PMD-12D13ME INPUT 3W(DC 13V)24L/Hr		
Drain float switch	FS	Open/short detection Initial contact resistance 500 mΩ or less		

Component	Sym- bol	PEFY- M40VMA(L)-A	PEFY- M50VMA(L)-A	PEFY- M63VMA(L)-A	PEFY- M71VMA(L)-A	PEFY- M80VMA(L)-A
Room temperature thermistor	TH21	Resistance 0°C/15kΩ, 10°C/9.6kΩ, 20°C/6.3kΩ, 25°C/5.4kΩ, 30°C/4.3kΩ, 40°C/3.0kΩ				
Liquid pipe thermistor	TH22	Resistance 0°C/15kΩ, 10°C/9.6kΩ, 20°C/6.3kΩ, 25°C/5.4kΩ, 30°C/4.3kΩ, 40°C/3.0kΩ				
Gas pipe thermistor	TH23	Resistance 0°C/15kΩ, 10°C/9.6kΩ, 20°C/6.3kΩ, 25°C/5.4kΩ, 30°C/4.3kΩ, 40°C/3.0kΩ				
Fuse	F01	AC250V 6.3A				
	F02	DC400V 3A				
Fan motor		8-pole, Output 121W ZWB278D54A				
Linear expansion valve	LEV	12VDC Stepping motor (0~2000 pulse)				
Power supply terminal block	TB2	(L, N, ⊕) 250V 20A				
Transmission terminal block	TB5 TB15	(1, 2) 250V 15A, (M1, M2, S) 250V 20A				
Drain pump		PMD-12D13ME INPUT 3W(DC 13V)24L/Hr				
Drain float switch	FS	Open/short detection Initial contact resistance 500 mΩ or less				

Component	Symbol	PEFY-M100VMA(L)-A	PEFY-M125VMA(L)-A	PEFY-M140VMA(L)-A
Room temperature thermistor	TH21	Resistance 0°C/15kΩ, 10°C/9.6kΩ, 20°C/6.3kΩ, 25°C/5.4kΩ, 30°C/4.3kΩ, 40°C/3.0kΩ		
Liquid pipe thermistor	TH22	Resistance 0°C/15kΩ, 10°C/9.6kΩ, 20°C/6.3kΩ, 25°C/5.4kΩ, 30°C/4.3kΩ, 40°C/3.0kΩ		
Gas pipe thermistor	TH23	Resistance 0°C/15kΩ, 10°C/9.6kΩ, 20°C/6.3kΩ, 25°C/5.4kΩ, 30°C/4.3kΩ, 40°C/3.0kΩ		
Fuse	F01	AC250V 6.3A		
	F02	DC400V 3A		
Fan motor		10-pole, Output 300W ZWB3710D01A		
Linear expansion valve	LEV	12VDC Stepping motor (0~2000 pulse)		
Power supply terminal block	TB2	(L, N, ⊕) 250V 20A		
Transmission terminal block	TB5 TB15	(1, 2) 250V 15A, (M1, M2, S) 250V 20A		
Drain pump		PMD-12D13ME INPUT 3W(DC 13V)24L/Hr		
Drain float switch	FS	Open/short detection Initial contact resistance 500 mΩ or less		

Component	Symbol	PEFY-M20VMA2-A	PEFY-M25VMA2-A	PEFY-M32VMA2-A	PEFY-M40VMA2-A
Room temperature thermistor	TH21	Resistance 0°C/15kΩ, 10°C/9.6kΩ, 20°C/6.3kΩ, 25°C/5.4kΩ, 30°C/4.3kΩ, 40°C/3.0kΩ			
Liquid pipe thermistor	TH22	Resistance 0°C/15kΩ, 10°C/9.6kΩ, 20°C/6.3kΩ, 25°C/5.4kΩ, 30°C/4.3kΩ, 40°C/3.0kΩ			
Gas pipe thermistor	TH23	Resistance 0°C/15kΩ, 10°C/9.6kΩ, 20°C/6.3kΩ, 25°C/5.4kΩ, 30°C/4.3kΩ, 40°C/3.0kΩ			
Fuse	F01	AC250V 6.3A			
	F02	DC400V 3A			
Fan motor		8-pole, Output 121W ZWB278D54A			
Linear expansion valve	LEV	12VDC Stepping motor (0~2000 pulse)			
Power supply terminal block	TB2	(L, N, ⊕) 250V 20A			
Transmission terminal block	TB5 TB15	(1, 2) 250V 15A, (M1, M2, S) 250V 20A			
Drain pump		PMD-12D13ME INPUT 3W(DC 13V)24L/Hr			
Drain float switch	FS	Open/short detection Initial contact resistance 500 mΩ or less			

Component	Sym- bol	PEFY-M50VMA2-A	PEFY-M63VMA2-A	PEFY-M71VMA2-A
Room temperature thermistor	TH21	Resistance 0°C/15kΩ, 10°C/9.6kΩ, 20°C/6.3kΩ, 25°C/5.4kΩ, 30°C/4.3kΩ, 40°C/3.0kΩ		
Liquid pipe thermistor	TH22	Resistance 0°C/15kΩ, 10°C/9.6kΩ, 20°C/6.3kΩ, 25°C/5.4kΩ, 30°C/4.3kΩ, 40°C/3.0kΩ		
Gas pipe thermistor	TH23	Resistance 0°C/15kΩ, 10°C/9.6kΩ, 20°C/6.3kΩ, 25°C/5.4kΩ, 30°C/4.3kΩ, 40°C/3.0kΩ		
Fuse	F01	AC250V 6.3A		
	F02	DC400V 3A		
Fan motor		10-pole, Output 300W ZWB3710D01A		
Linear expansion valve	LEV	12VDC Stepping motor (0~2000 pulse)		
Power supply terminal block	TB2	(L, N, ⊕) 250V 20A		
Transmission terminal block	TB5 TB15	(1, 2) 250V 15A, (M1, M2, S) 250V 20A		
Drain pump		PMD-12D13ME INPUT 3W(DC 13V)24L/Hr		
Drain float switch	FS	Open/short detection Initial contact resistance 500 mΩ or less		

Component	Sym- bol	PEFY-M80VMA2-A	PEFY-M100VMA2-A	PEFY-M125VMA2-A
Room temperature thermistor	TH21	Resistance 0°C/15kΩ, 10°C/9.6kΩ, 20°C/6.3kΩ, 25°C/5.4kΩ, 30°C/4.3kΩ, 40°C/3.0kΩ		
Liquid pipe thermistor	TH22	Resistance 0°C/15kΩ, 10°C/9.6kΩ, 20°C/6.3kΩ, 25°C/5.4kΩ, 30°C/4.3kΩ, 40°C/3.0kΩ		
Gas pipe thermistor	TH23	Resistance 0°C/15kΩ, 10°C/9.6kΩ, 20°C/6.3kΩ, 25°C/5.4kΩ, 30°C/4.3kΩ, 40°C/3.0kΩ		
Fuse	F01	AC250V 6.3A		
	F02	DC400V 3A		
Fan motor		10-pole, Output 300W ZWB3710D01A		
Linear expansion valve	LEV	12VDC Stepping motor (0~2000 pulse)		
Power supply terminal block	TB2	(L, N, ⊕) 250V 20A		
Transmission terminal block	TB5 TB15	(1, 2) 250V 15A, (M1, M2, S) 250V 20A		
Drain pump		PMD-12D13ME INPUT 3W(DC 13V)24L/Hr		
Drain float switch	FS	Open/short detection Initial contact resistance 500 mΩ or less		

[1] Outlines and Dimensions

1. PEFY-M20, 25, 32, 40, 50, 63, 71, 80, 100, 125, 140VMA-A

Unit: mm

- Note 1. Use M10 screw for the Suspension bolt (field supply).
- 2. Keep the service space for the maintenance at the bottom.
- 3. This chart indicates for PEFY-M71-80VMA-A models, which have 2 fans. PEFY-M20-25-32VMA-A models have 1 fan. PEFY-M40-50-63VMA-A models have 2 fans. PEFY-M100-125-140VMA-A models have 3 fans.
- 4. In case of the inlet duct is used, remove the air filter (supply with the unit), then install the filter (field supply) at suction side.

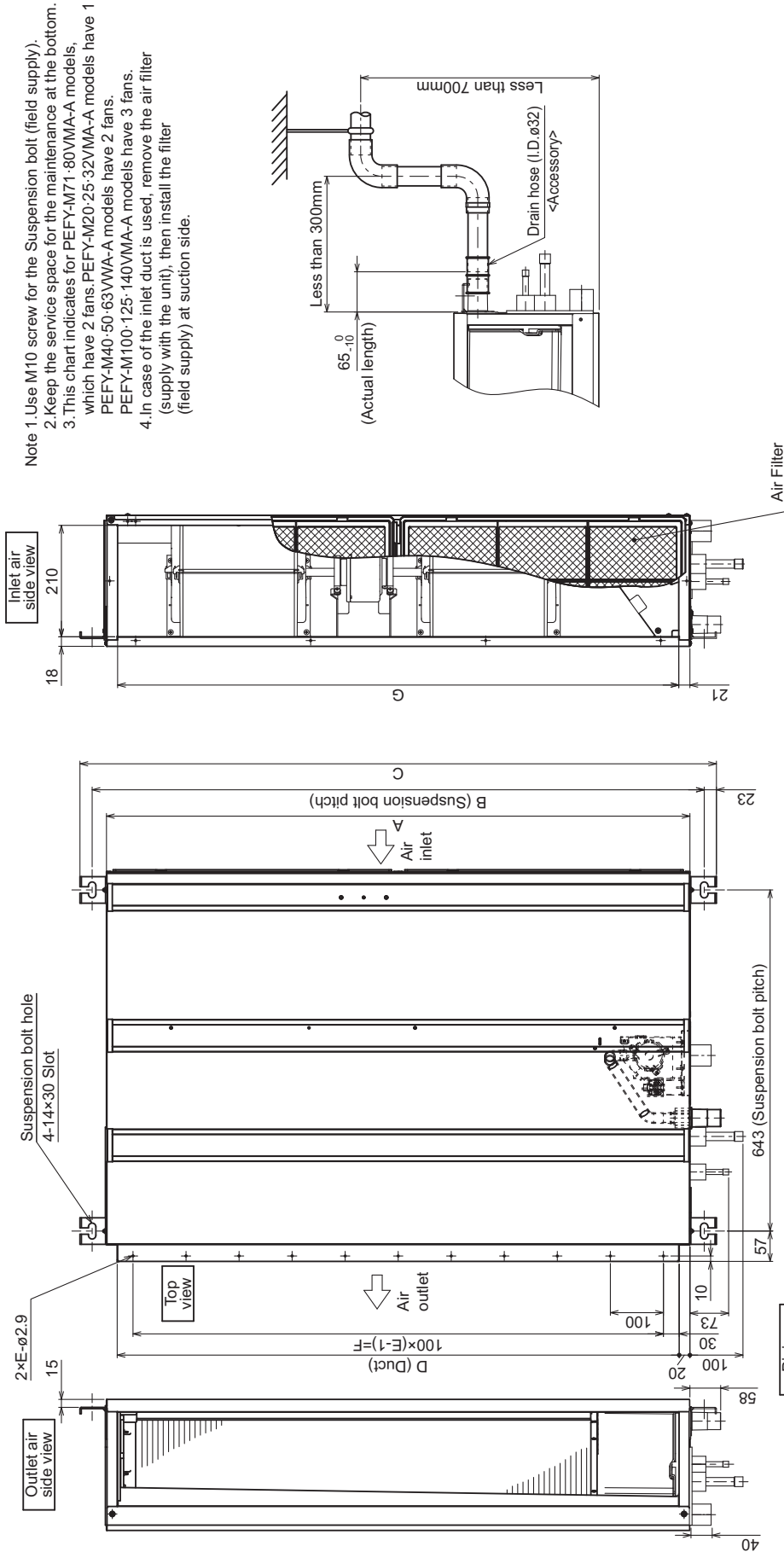

Model	A	B	C	D	E	F	G	① Gas pipe	② Liquid pipe
PEFY-M20, 25, 32VMA-A	700	754	800	660	7	600	658	ø12.7	ø6.35
PEFY-M40, 50VMA-A	900	954	1000	860	9	800	858		
PEFY-M63VMA-A	900	954	1000	860	9	800	858		
PEFY-M71, 80VMA-A	1100	1154	1200	1060	11	1000	1058	ø15.88	ø9.52
PEFY-M100, 125VMA-A	1400	1454	1500	1360	14	1300	1358		
PEFY-M140VMA-A	1600	1654	1700	1560	16	1500	1558		

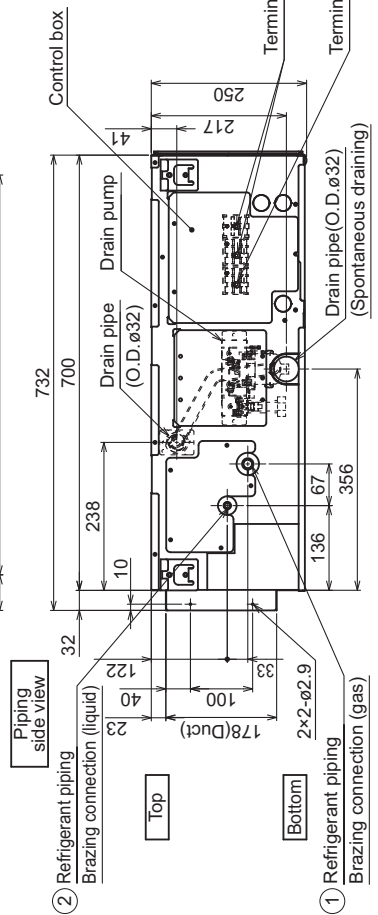

2. PEFY-M20, 25, 32, 40, 50, 63, 71, 80, 100, 125, 140VMAL-A

Unit: mm

- Note 1. Use M10 screw for the Suspension bolt (field supply).
- 2. Keep the service space for the maintenance at the bottom.
- 3. This chart indicates for PEFY-M71-80VMAL-A models, which have 2 fans. PEFY-M20-25-32VMAL-A models, which have 2 fans. PEFY-M40-50-63VMAL-A models have 2 fans. PEFY-M100-125-140VMAL-A models have 3 fans.
- 4. In case of the inlet duct is used, remove the air filter (supply with the unit), then install the filter (field supply) at suction side.

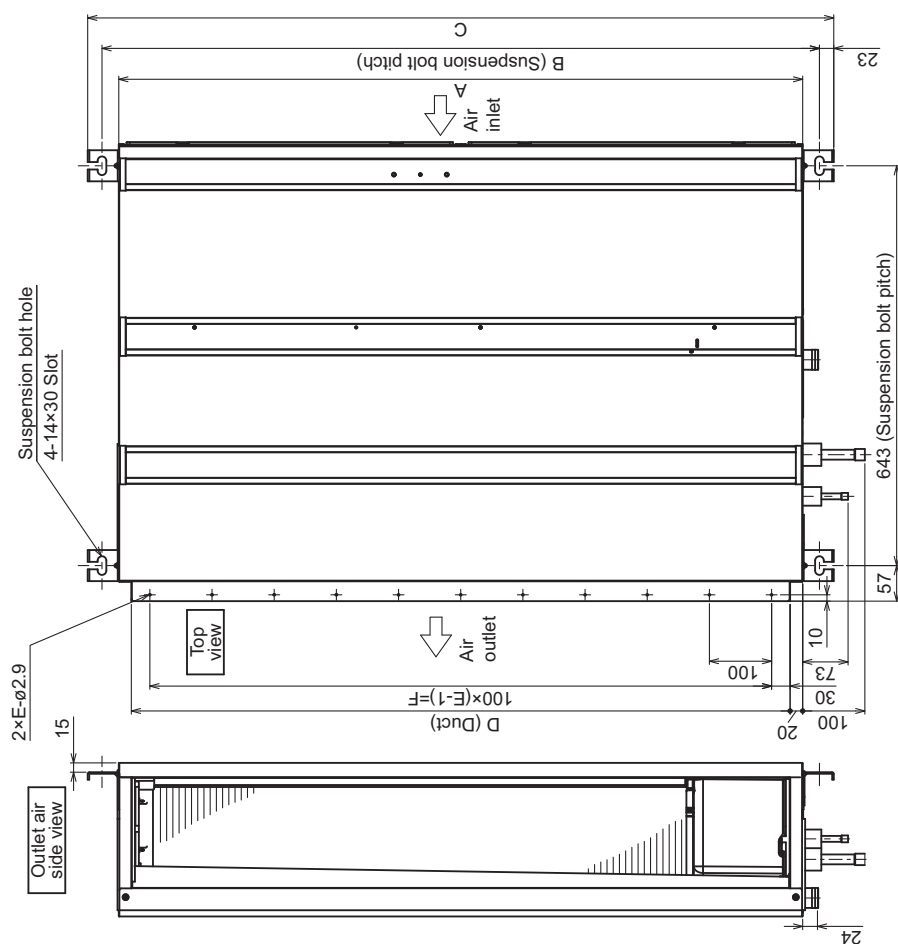
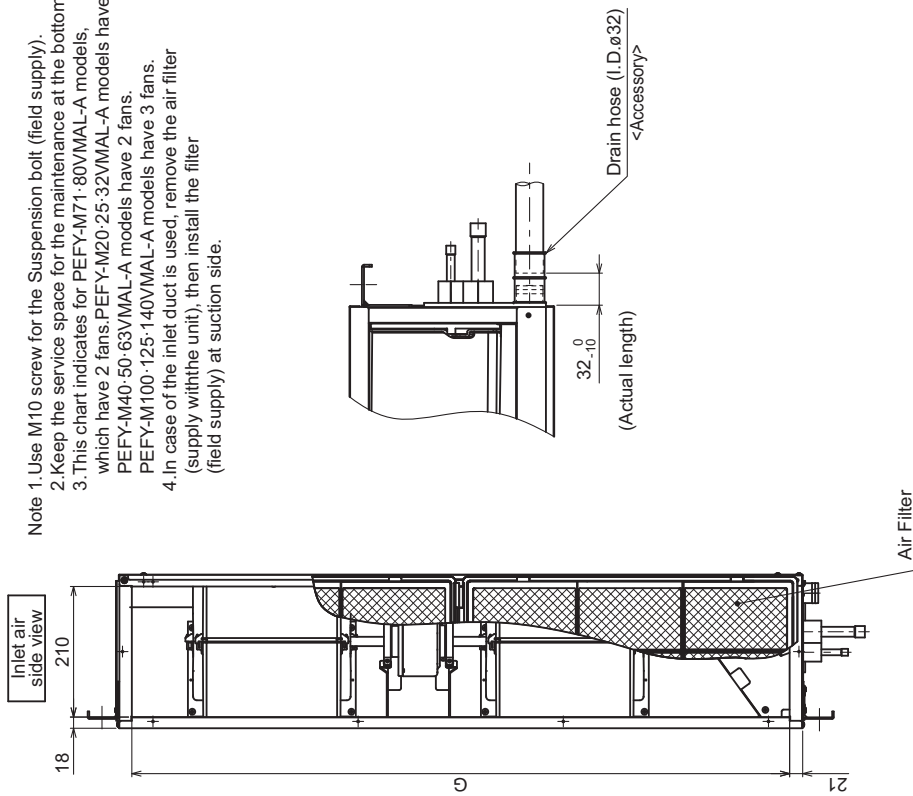

Model	A	B	C	D	E	F	G	① Gas pipe	② Liquid pipe
PEFY-M20, 25, 32VMAL-A	700	754	800	660	7	600	656	ø12.7	ø6.35
PEFY-M40, 50VMAL-A	900	954	1000	860	9	800	858		
PEFY-M63VMAL-A	900	954	1000	860	9	800	858		
PEFY-M71, 80VMAL-A	1100	1154	1200	1060	11	1000	1058	ø15.88	ø9.52
PEFY-M100, 125VMAL-A	1400	1454	1500	1360	14	1300	1358		
PEFY-M140VMAL-A	1600	1654	1700	1560	16	1500	1558		

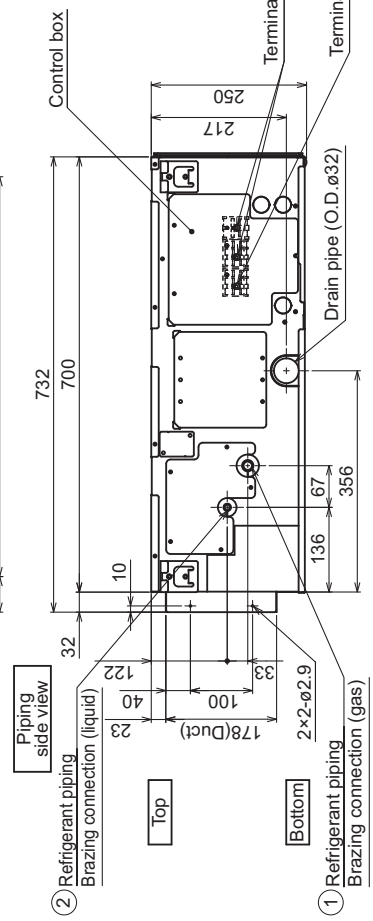

[2] Service Space

1. PEFY-M20, 25, 32, 40, 50, 63, 71, 80, 100, 125, 140VMA-A

Unit: mm

[Maintenance access space]
 Secure enough access space to allow for the maintenance, inspection, and replacement of the motor, fan, drain pump, heat exchanger, and control box in one of the following ways.

Select an installation site for the indoor unit so that its maintenance access space will not be obstructed by beams or other objects.

- (1) When a space of 300mm or more is available below the unit between the unit and the ceiling. (Fig.1)
- Create access door 1 and 2 (450x450mm each) as shown in Fig.2.

(Access door 2 is not required if enough space is available below the unit for a maintenance worker to work in.)

- (2) When a space of less than 300mm is available below the unit between the unit and the ceiling.

(At least 20mm of space should be left below the unit as shown in Fig.3.)

- Create access door 1 diagonally below the control box and access door 3 below the unit as shown in Fig.4.
- or
- Create access door 4 below the control box and the unit as shown in Fig.5.

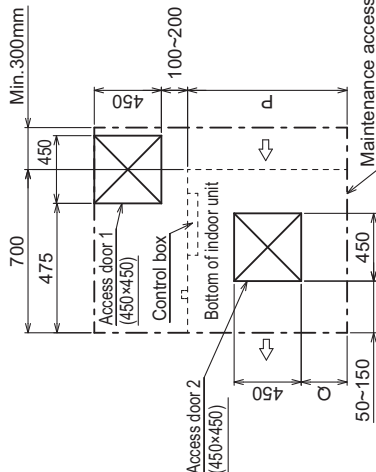
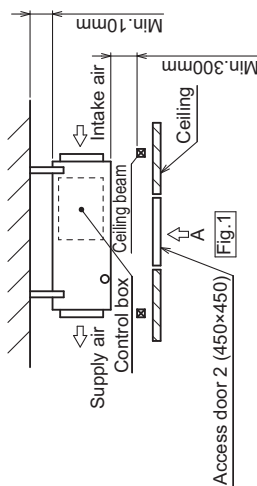

Fig.2 (Viewed from the direction of the arrow A)

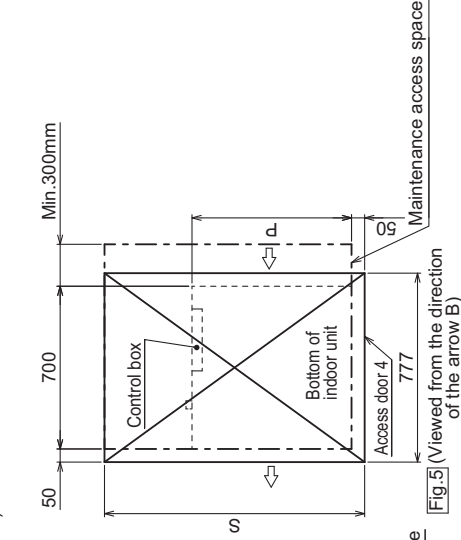
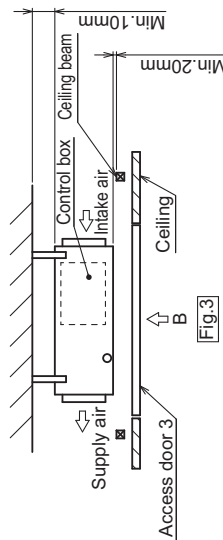

Fig.4 (Viewed from the direction of the arrow B)

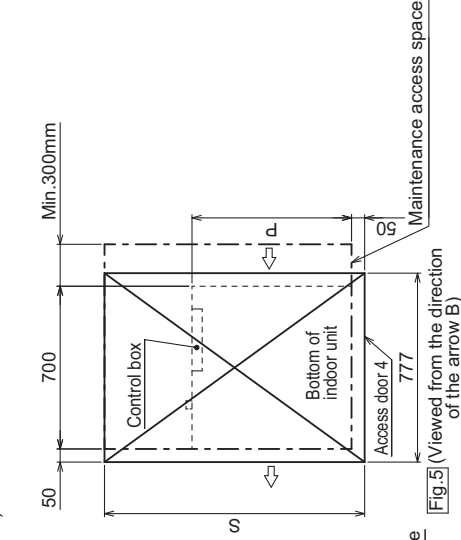

Fig.5 (Viewed from the direction of the arrow B)

Model	H	J	K	L	M	N	P	Q	R	S
PEFY-M20, 25, 32VMA-A	44	150	300	4	780	10	700	50~150	800	1300
PEFY-M40, 50, 63VMA-A	54	260	4	990	10	900	150~250	1000	1500	1700
PEFY-M71, 80VMA-A	49	330	4	1100	12	1100	250~350	1200	1700	2000
PEFY-M100, 125VMA-A	54	320	5	1280	12	1400	400~500	1500	2000	2200
PEFY-M140VMA-A	54	370	5	1480	12	1600	500~600	1700	2200	2200

2. PEFY-M20, 25, 32, 40, 50, 63, 71, 80, 100, 125, 140VMAL-A

Unit: mm

[Maintenance access space]
 Secure enough access space to allow for the maintenance, inspection, and replacement of the motor, fan, heat exchanger, and control box in one of the following ways.
 Select an installation site for the indoor unit so that its maintenance access space will not be obstructed by beams or other objects.
 (1) When a space of 300mm or more is available below the unit between the unit and the ceiling. (Fig.1)
 · Create access door 1 and 2 (450×450mm each) as shown in Fig.2.
 (Access door 2 is not required if enough space is available below the unit for a maintenance worker to work in.)

(2) When a space of less than 300mm is available below the unit between the unit and the ceiling.

- (At least 20mm of space should be left below the unit as shown in Fig.3.)
- Create access door 1 diagonally below the control box and access door 3 below the unit as shown in Fig.4.
- or
- Create access door 4 below the control box and the unit as shown in Fig.5.

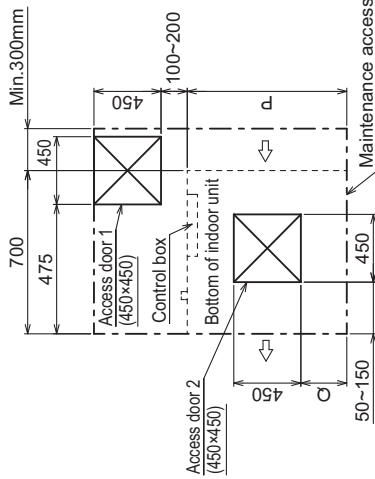
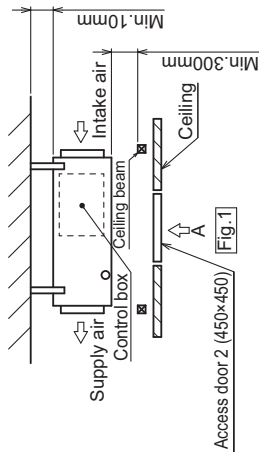

[Fig.2] (Viewed from the direction of the arrow A)

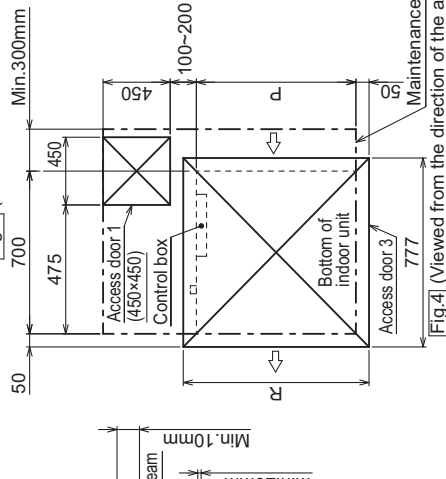

[Fig.4] (Viewed from the direction of the arrow B)

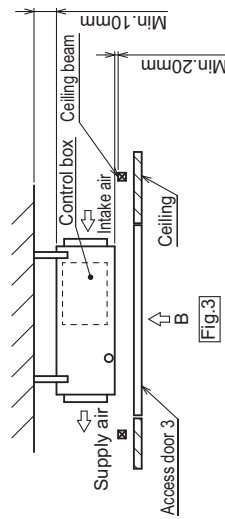

[Fig.3]

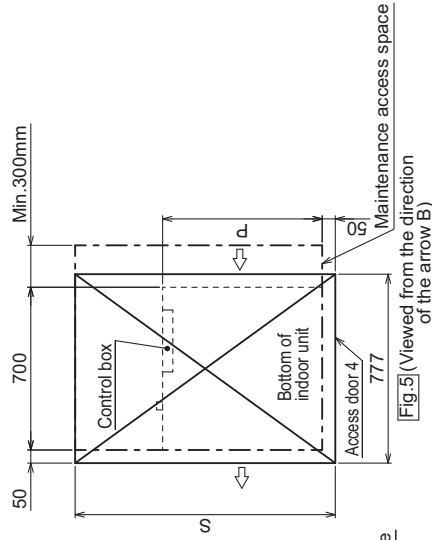
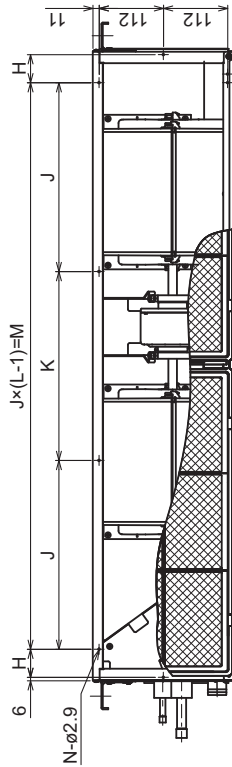

[Fig.5] (Viewed from the direction of the arrow B)

Model	H	J	K	L	M	N	P	Q	R	S
PEFY-M20, 25, 32VMAL-A	44	150	300			10	700	50~150	800	1300
PEFY-M40, 50, 63VMAL-A	54	260		4	780	10	900	150~250	1000	1500
PEFY-M71, 80VMAL-A	49	330		4	990	10	1100	250~350	1200	1700
PEFY-M100, 125VMAL-A	54	320		5	1280	12	1400	400~500	1500	2000
PEFY-M140VMAL-A	54	370		5	1480	12	1600	500~600	1700	2200

3. PEFY-M20, 25, 32, 40, 50, 63, 71, 80, 100, 125VMA2-A

Unit: mm

[Maintenance access space]
 Secure enough access space to allow for the maintenance, inspection, and replacement of the motor, fan, drain pump, heat exchanger, and control box in one of the following ways.

Select an installation site for the indoor unit so that its maintenance access space will not be obstructed by beams or other objects.

(1) When a space of 300mm or more is available below the unit between the unit and the ceiling. (Fig.1)

- Create access door 1 and 2 (450x450mm each) as shown in Fig.2.

(Access door 2 is not required if enough space is available below the unit for a maintenance worker to work in.)

(2) When a space of less than 300mm is available below the unit between the unit and the ceiling.

(At least 20mm of space should be left below the unit as shown in Fig.3.)

- Create access door 1 diagonally below the control box and access door 3 below the unit as shown in Fig.4.

or

- Create access door 4 below the control box and the unit as shown in Fig.5.

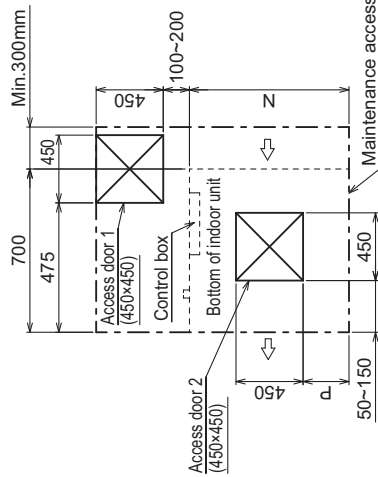
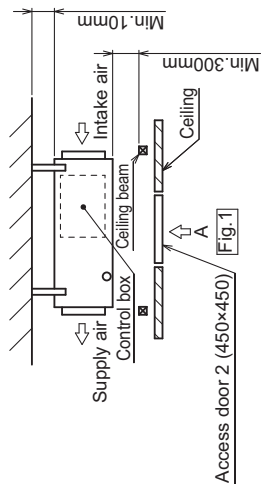

[Fig.2] (Viewed from the direction of the arrow A)

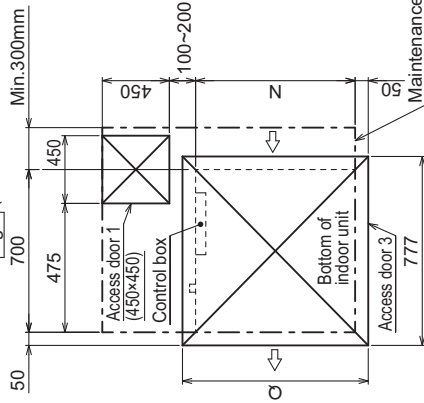

[Fig.4] (Viewed from the direction of the arrow B)

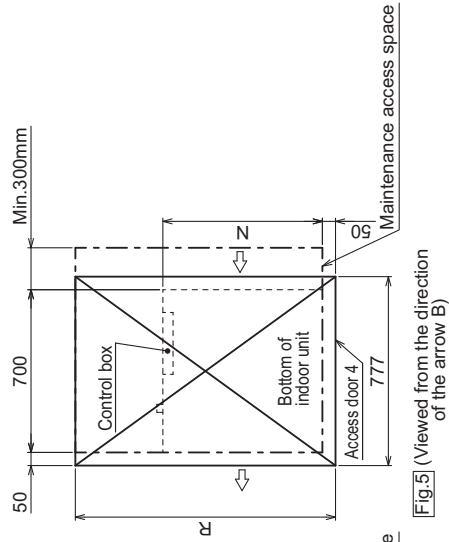

[Fig.5] (Viewed from the direction of the arrow B)

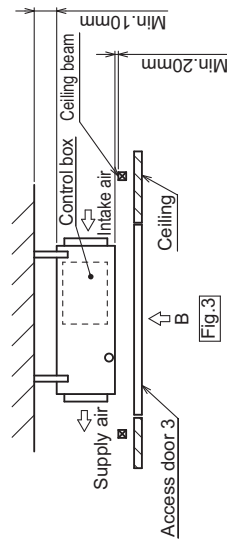

[Fig.3]

Model	H	J	K	L	M	N	P	Q	R
PEFY-M20, 25, 32VMA2-A	54	260	4	780	10	900	150~250	1000	1500
PEFY-M40VMA2-A	49	330	4	990	10	1100	250~350	1200	1700
PEFY-M50, 63, 71, 80, 100, 125VMA2-A	54	370	5	1480	12	1600	500~600	1700	2200

[1] Wiring Diagram

1. PEFY-M20, 25, 32, 40, 50, 63, 71, 80, 100, 125, 140VMA(L)-A

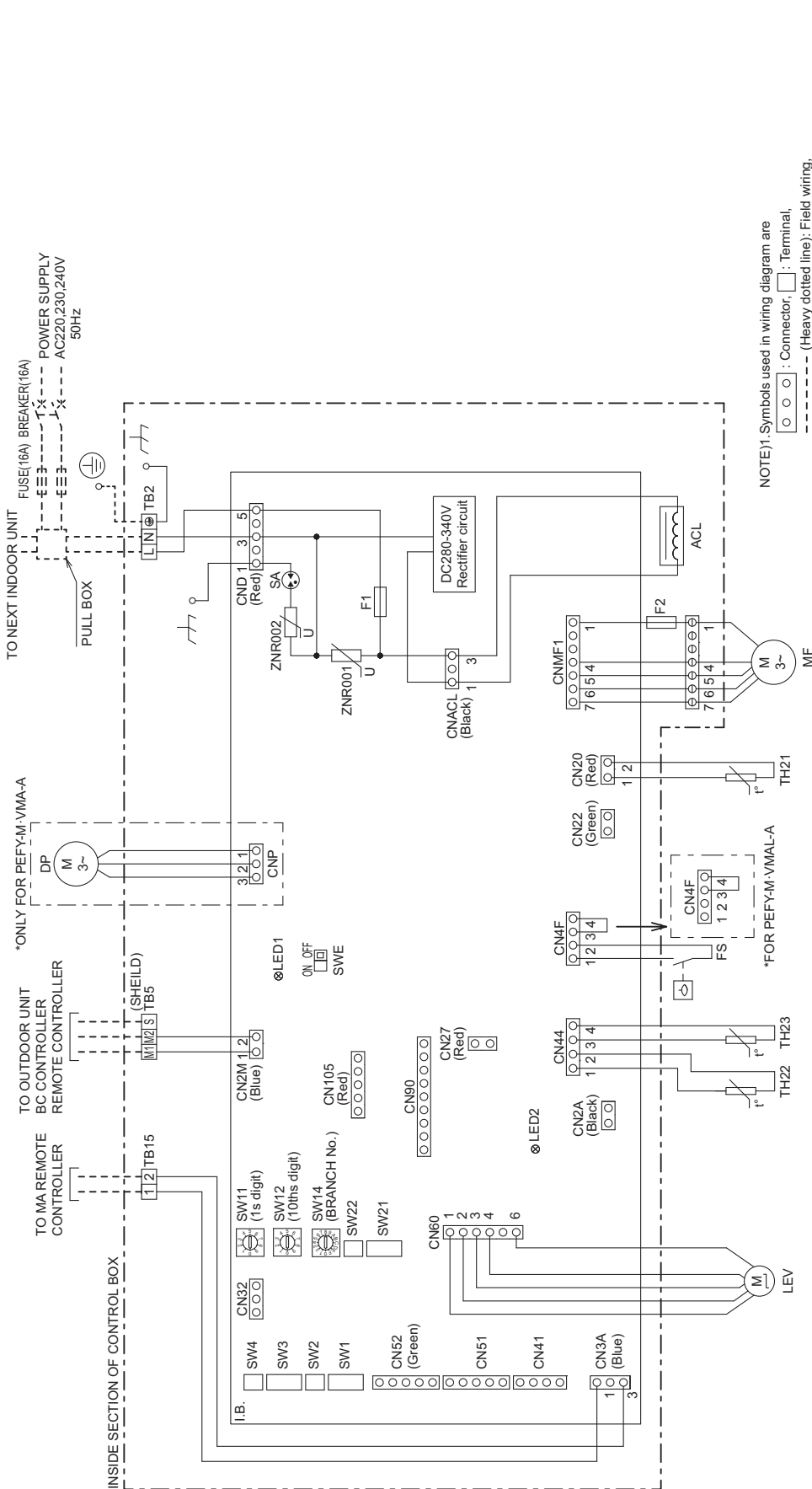

NOTE)1. Symbols used in wiring diagram are
 ○ ○ ○ : Connector, □ : Terminal,
 - - - (Heavy dotted line): Field wiring,
 2. Have all electric work done by a licensed electrician according to the local regulations.
 3. Earth leakage circuit breaker should be set up on the wiring of the power supply.
 4. To perform a drainage test for the drain pump turn on the SWE on the control board while the indoor unit is being powered.
 *Be sure to turn off the SWE after completing a drainage test or test run.

SYMBOL	NAME	SYMBOL	NAME	SYMBOL	NAME
ACL	AC reactor(Power factor improvement)	I.B.	Indoor controller board	I.B.	Indoor controller board
DP	Drain Pump	SA	Arrestor	SW1	Switch (for mode selection)
F2	Fuse DC400V 3A	F1	Fuse AC250V 6.3A	SW2	Switch (for capacity code)
FS	Float switch	ZNR01.002	Varistor	SW3	Switch (for model selection)
MF	Fan Motor	CN2A	Connector (0-10V Analog input)	SW4	Switch (for model selection)
LEV	Linear expansion valve	CN22	Connector (Optional Thermistor)	SW11	Switch (1's digit address set)
TB2	Power source terminal block	CN27	Connector (Dampner)	SW12	Switch (10ths digit address set)
TB5	Transmission terminal block	CN32	Connector (Remote switch)	SW14	Switch (BRANCH No.)
TB15	Transmission terminal block	CN41	Connector (HA terminal-A)	SW21	Switch (for static pressure selection)
TH21	Thermistor (inlet air temp. detection)	CN51	Connector (Centrally control)	SW22	Switch (Wireless pair No.)
TH22	Thermistor (piping temp.detection/liquid)	CN52	Connector (Remote indication)	SWE	Connector (emergency operation)
TH23	Thermistor (piping temp.detection/gas)	CN90	Connector (Wireless)	LED1	LED(Power supply)
		CN105	Connector (IT terminal)	LED2	LED(Remote controller supply)

2. PEFY-M20, 25, 32, 40, 50, 63, 71, 80, 100, 125VMA2-A

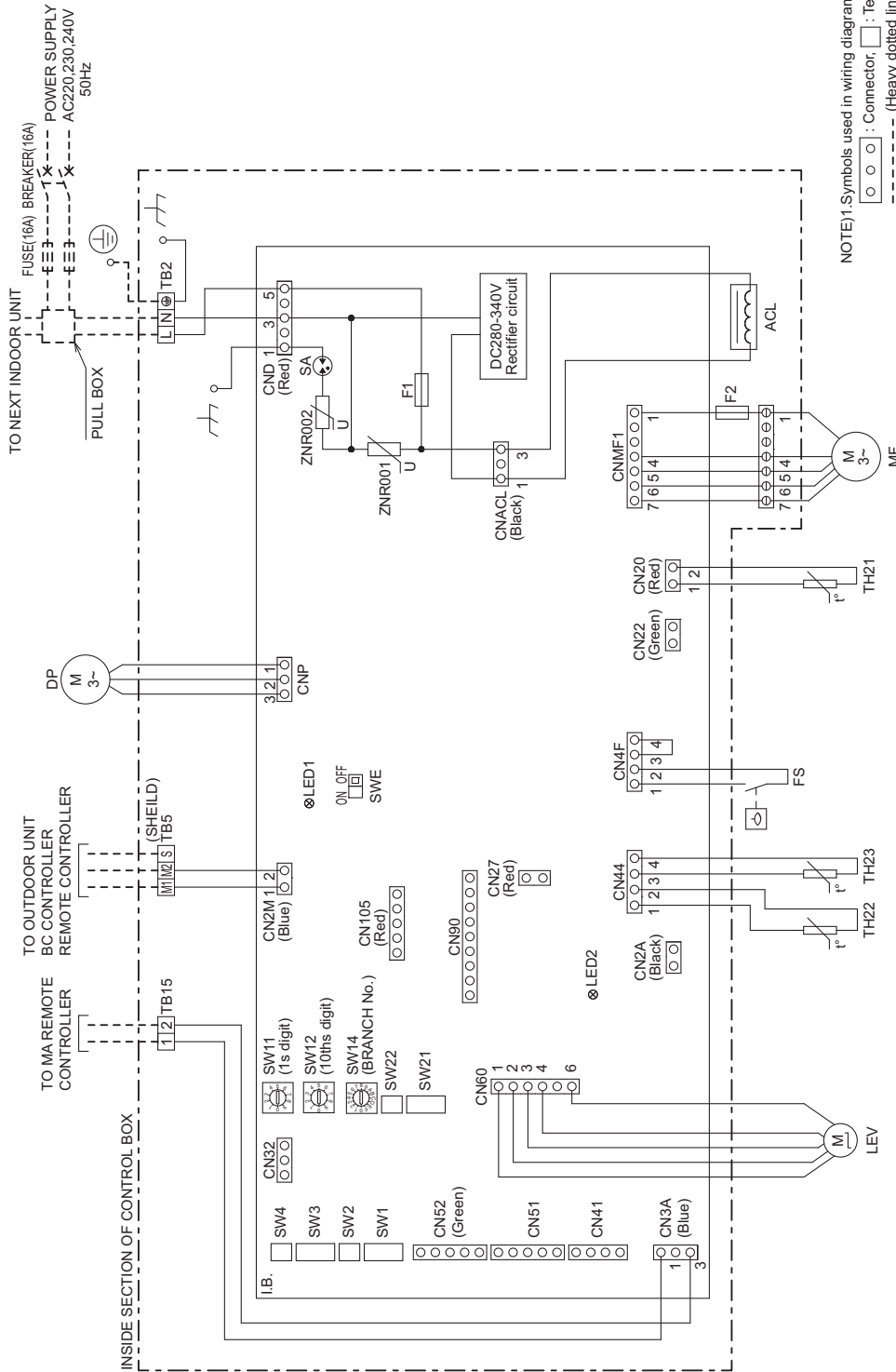

NOTE)1. Symbols used in wiring diagram are

- ○ ○ ○ : Connector, □ : Terminal,
- ○ ○ ○ : Terminal,
- (Heavy dotted line) : Field wiring,

2. Have all electric work done by a licensed electrician according to the local regulations.
 3. Earth leakage circuit breaker should be set up on the wiring of the power supply.
 4. To perform a drainage test for the drain pump turn on the SWE on the control board while the indoor unit is being powered.
- *Be sure to turn off the SWE after completing a drainage test or test run.

SYMBOL EXPLANATION

SYMBOL	NAME	SYMBOL	NAME	SYMBOL	NAME
ACL	AC reactor(Power factor improvement)	I.B.	Indoor controller board	SW1	Indoor controller board
DP	Drain Pump	SA	Arrester	SW2	Switch (for mode selection)
F2	Fuse DC400V 3A	F1	Fuse AC250V 6.3A	SW3	Switch (for capacity code)
FS	Float switch	ZNR01,002	Varistor	SW4	Switch (for mode selection)
MF	Fan Motor	CN2A	Connector (0-10V Analog input)	SW11	Switch (for model selection)
LEV	Linear expansion valve	CN22	Connector (Optional Thermistor)	SW12	Switch (1s digit address set)
TB2	Power source terminal block	CN27	Connector (Damper)	SW14	Switch (BRANCH No.)
TB5	Transmission terminal block	CN32	Connector (Remote switch)	SW21	Switch (for static pressure selection)
TB15	Transmission terminal block	CN41	Connector (HA terminal-A)	SW22	Switch (Wireless pair No.)
TH21	Thermistor (Inlet air temp. detection)	CN51	Connector (Centrally control)	SW1	LED(Power supply)
TH22	Thermistor (piping temp. detection/liquid)	CN52	Connector (Remote indication)	LED2	LED(Remote controller supply)
TH23	Thermistor (piping temp. detection/gas)	CN90	Connector (Wireless)		
		CN105	Connector (IT terminal)		

[1] Refrigerant system diagram

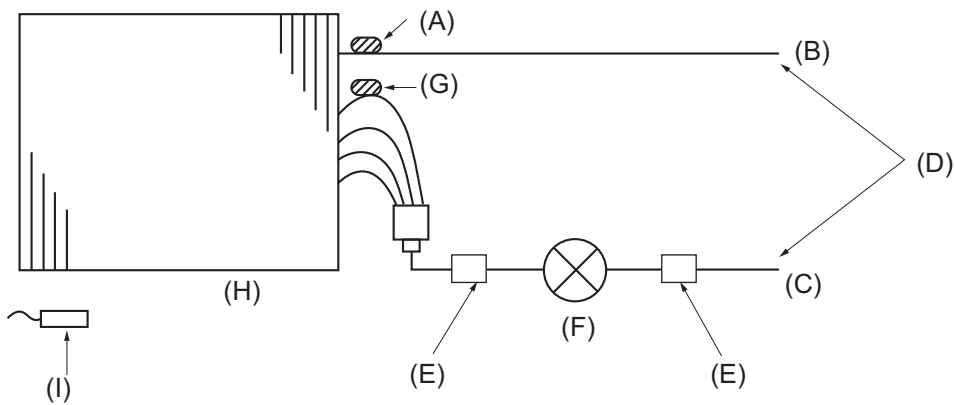

- (A) Gas pipe thermistor TH23
- (B) Gas pipe
- (C) Liquid pipe
- (D) Brazed connections
- (E) Strainer (#100 mesh)
- (F) Linear expansion valve
- (G) Liquid pipe thermistor TH22
- (H) Heat exchanger
- (I) Room temperature thermistor TH21

Capacity	PEFY- M20, 25, 32, 40, 50VMA(L)(2)-A	PEFY- M63, 71, 80, 100, 125, 140VMA(L)-A	PEFY- M63, 71, 80, 100, 125VMA2-A
Gas pipe	ø12.7 [1/2]	ø15.88 [5/8]	
Liquid pipe	ø6.35 [1/4]	ø9.52 [3/8]	

[1] Troubleshooting

1. Check methods

1. Component and check points

(1) Thermistor

- Room temperature thermistor (TH21)
- Liquid pipe thermistor (TH22)
- Gas pipe thermistor (TH23)

Disconnect the connector and measure the resistance between terminals with a tester.
(Ambient temperature 10°C - 30°C)

Normal	Abnormal
4.3kΩ - 9.6kΩ	Open or short

(Refer to the thermistor characteristic graph below.)

1) Thermistor characteristic graph

Low-temperature thermistor

- Room temperature thermistor (TH21)
- Liquid pipe thermistor (TH22)
- Gas pipe thermistor (TH23)
- Drain sensor (DS)

- Thermistor $R_0 = 15\text{ k}\Omega \pm 3\%$
- Multiplier of B = $3480\text{ k}\Omega \pm 2\%$

$$R_t = 15 \exp \left\{ 3480 \left(\frac{1}{273+t} - \frac{1}{273} \right) \right\}$$

- 0°C 15kΩ
- 10°C 9.6kΩ
- 20°C 6.3kΩ
- 25°C 5.2kΩ
- 30°C 4.3kΩ
- 40°C 3.0kΩ

(A) Temperature (°C)

(B) Resistance (kΩ)

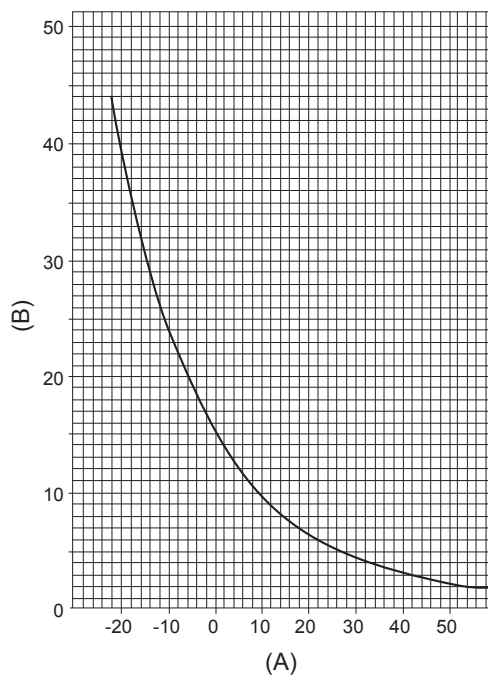

(2) Fan motor (CNMF)

Refer to the page on "DC fan motor (fan motor/indoor control board)."

(3) Linear expansion valve

Disconnect the connector, and measure the resistance between terminals with a tester.
Refer to the next page for details.

	Normal				Abnormal
	1-6 White-Red	2-6 Yellow-Red	3-6 Orange-Red	4-6 Blue-Red	
(150Ω) ±10%					Open or short

- (A) Red
- (B) Blue
- (C) Orange
- (D) Yellow
- (E) White
- (F) White

1) Summary of linear expansion valve (LEV) operation

- The LEV is operated by a stepping motor, which operates by receiving a pulse signal from the indoor control board.
- The LEV position changes in response to the pulse signal.

Indoor control board and LEV connection

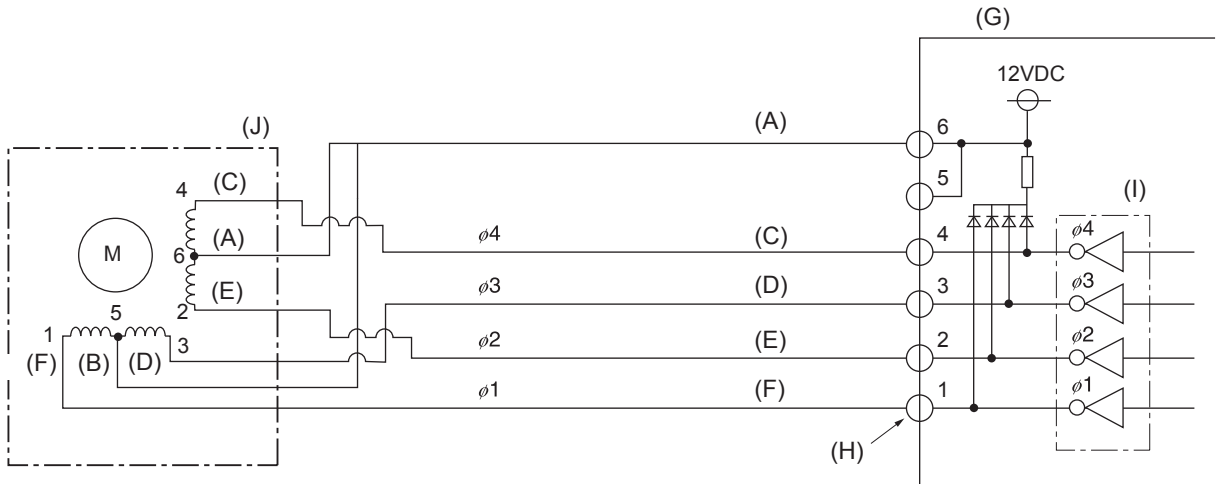

- | | |
|------------|----------------------------|
| (A) Red | (G) Control board |
| (C) Blue | (H) Connection (CN60) |
| (D) Orange | (I) Drive circuit |
| (E) Yellow | (J) Linear expansion valve |
| (F) White | |

Pulse signal output and valve operation

Phase number	Output pulse			
	1	2	3	4
ø1	ON	OFF	OFF	ON
ø2	ON	ON	OFF	OFF
ø3	OFF	ON	ON	OFF
ø4	OFF	OFF	ON	ON

The output pulse changes in the following order:

When the valve closes 1 -> 2 -> 3 -> 4 -> 1

When the valve opens 4 -> 3 -> 2 -> 1 -> 4

- When the valve position remains the same, all output signals will be OFF.
- If any output signal is missing or if the signal remains ON, the motor vibrates and makes clicking noise.

2) LEV operation

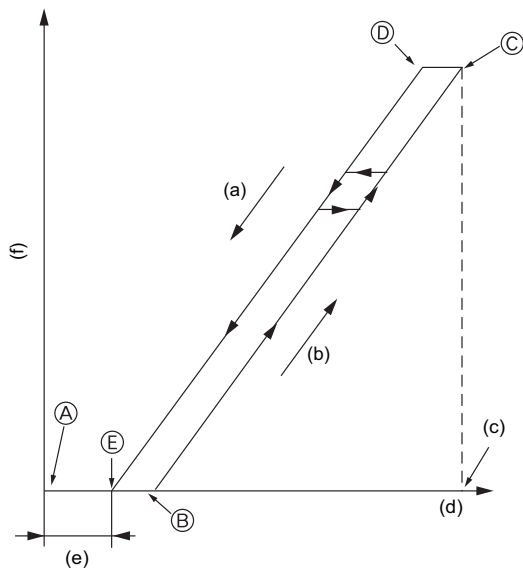

- (a) Close
- (b) Open
- (c) Fully open valve (2000 pulses)
- (d) No. of pulses
- (e) Extra tightening (41 pulses)
- (f) Valve opening degree

- When the power is turned on, a pulse signal of fully open pulse + 10% pulse is output (valve closure signal), to bring the valve to position A.
- When the valve is operating normally, it is free of vibration noise. If the valve locks or when it goes from point E to A in the figure, it makes louder noise than would be heard when there is an open phase.
- Check for abnormal sound/vibration by placing the metal tip of a screwdriver against the valve and the handle side against your ear.

3) Troubleshooting

Symptom	Checking Criteria	Remedy
Circuit failure on the microcomputer	Disconnect the connectors on the control board, and connect LEDs to test the circuit as shown below. Pulse signals are output for 10 seconds when the main power is turned on. If there are LEDs that do not light up at all or remain lit after the pulses are turned off, there is a problem with the driving circuit.	Replace the indoor control board if driving circuit failure is detected.
Locked LEV	The motor will idle and make small clicking noise if it is run while the LEV is locked. If this clicking noise is heard both when the valve is fully closed and while it is being opened, it indicates a problem.	Replace the LEV.
Disconnected or shorted LEV motor coils	Measure the resistance between the coils with a tester (red-white, red-orange, Red-yellow, Red-blue). The normal range of resistance is $150\Omega \pm 10\%$	Replace the LEV.

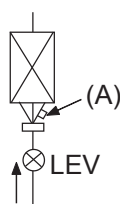
<p>Valve closure failure (leaky valve)</p>	<p>To check the LEV on the indoor unit, check the indoor unit liquid pipe temperature that appears on the operation monitor on the outdoor unit's multi control board while operating the indoor unit in question in the FAN mode and the other indoor units in the cooling mode.</p> <p>(A) Termistor (TH22)</p>  <p>Normally, the LEV is fully closed while the unit is in the FAN mode. If the valve is leaky, liquid pipe thermistor reading will be lower than normal. If it is significantly lower than the inlet temperature on the remote controller, valve closure failure is suspected. If the amount of leakage is insignificant, replacement of LEV is unnecessary unless it is causing a problem.</p>	<p>Replace the LEV if the amount of leakage is great.</p>
<p>Misconnections of connectors or contact failure</p>	<p>Perform a visual check for disconnected connectors. Perform a visual check of lead wire color.</p>	<p>Disconnect the connectors on the control board and perform a continuity test.</p>

(4) Drain pump

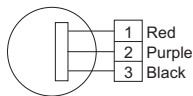

1. Check if the drain float switch works properly.
2. Check if the drain pump works and drains water properly in cooling operation.
3. If no water drains, confirm that the check code 2502 will not be displayed 10 minutes after the operation starts.

Note: The drain pump for this model is driven by the internal DC motor of controller board, so it is not possible to measure the resistance between the terminals.

Normal

Red-Black: Input 13V DC → The fan starts to rotate.

Purple-Black: Abnormal (check code 2502) if it outputs 0-13 V square wave (5 pulses/rotation), and the number of rotation is not normal.

(5) Drain float switch (CN4F)

Disconnect the connector, and measure the resistance between terminals with a tester.

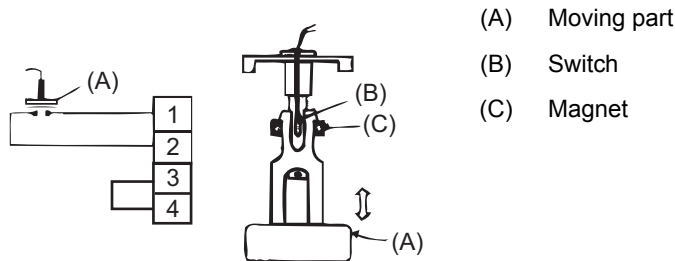

Position of the moving part	Normal	Abnormal
Up	Short	(any position but short)
Down	Open	(any position but open)

2. DC fan motor (fan motor/indoor control board)

1. CAUTION

- A high voltage is applied to the connector for connection to the fan motor (CNMF).
- Do not unplug the connector CNMF with the unit energized to avoid damage to the indoor control board and fan motor.

2. Troubleshooting

- Symptom: Indoor unit fan does not run.

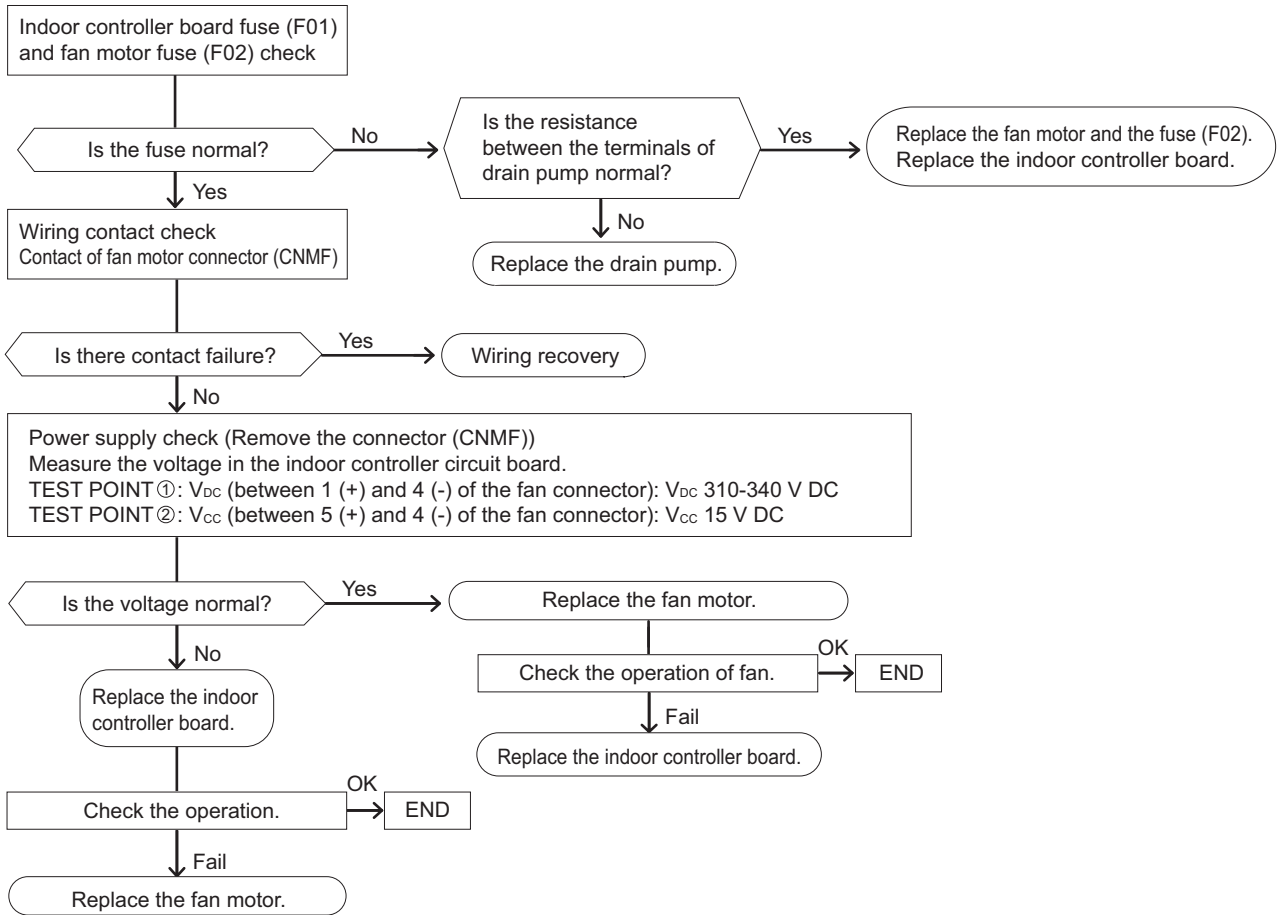

3. Address switch setting

Make sure that power to the unit is turned off.

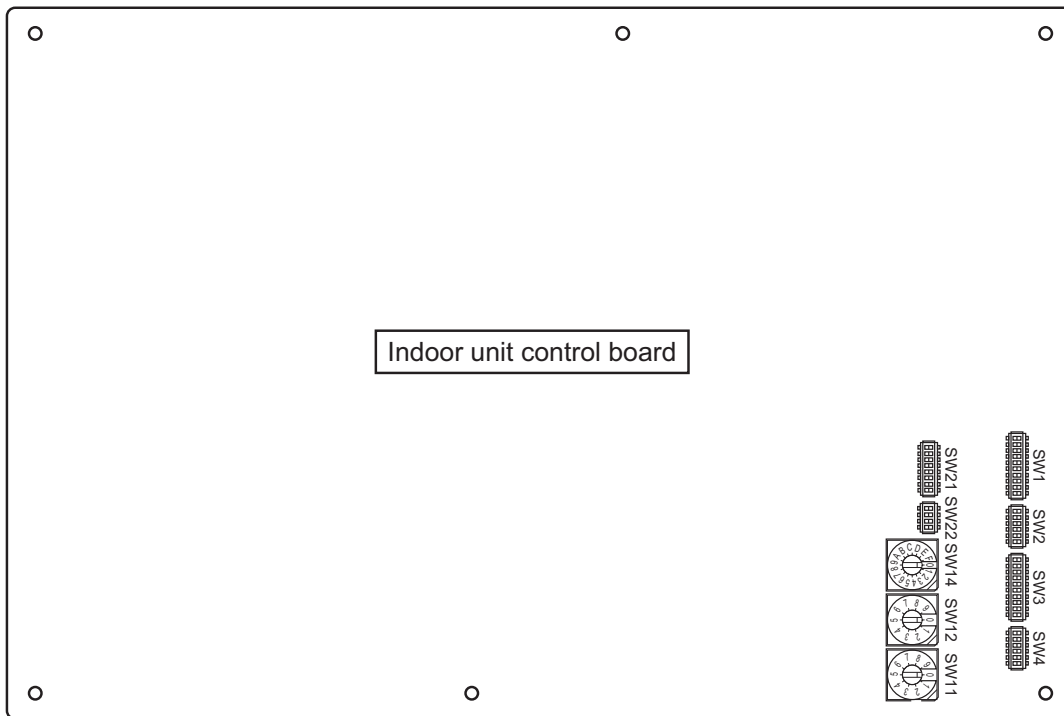

1. When using an ME remote controller, set the address with the rotary switches (SW11, SW12).

•Address setting is not required when the unit remote controller is used.

On-site address setting is required for the indoor units to run.

2. Address settings vary in different systems.

Refer to the section on address setting in the outdoor unit installation manual.

3. Address is set with a combination of SW12 (10's digit) and SW11 (1's digit).

To set the address to "3," set SW12 to "0" and SW11 to "3."

To set the address to "25," set SW 12 to "2" and SW 11 to "5."

4. Voltage test points on the control board

1. PEFY-M20, 25, 32, 40, 50, 63, 71, 80, 100, 125, 140VMA(L)-A, PEFY-M20, 25, 32, 40, 50, 63, 71, 80, 100, 125VMA2-A

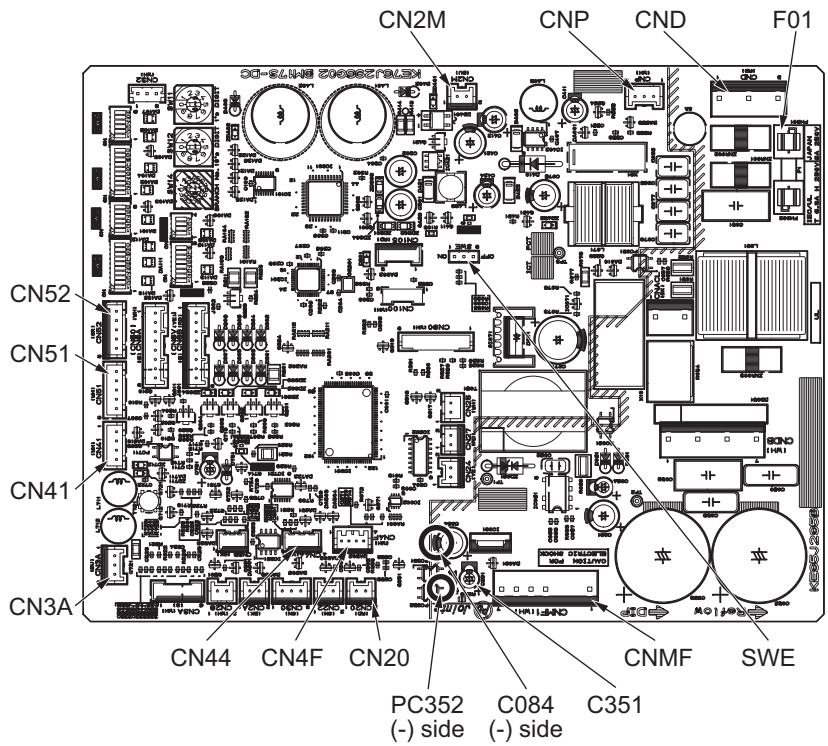

- F01 Fuse (AC 250V 6.3A)
- CND Power supply voltage (220 - 240VAC)
- CN2M For M-NET transmission cable connection (24 - 30VDC)
- SWE Emergency operation
- SW2 Capacity setting
- SW4 Function setting
- SW3 Function setting
- CN32 Remote start/stop adapter
- CN3A For MA remote controller cable connection (10 - 13 VDC (Between 1 and 3.))
- CN52 Remote display
- CN51 Centralized control
- CN41 JAMA standard HA terminal A
- CN44 Thermistor (liquid/gas temperature)
- CN4F Float switch
- CN20 Thermistor (Inlet temperature)
- CNMF Fan motor output
 1 - 4: 310 - 340 VDC
 5 - 4: 15 VDC
 6 - 4: 0 - 6.5 VDC
 7 - 4: Stop 0 or 15 VDC
 Run 7.5 VDC
 (0 - 15 pulse)

(*1)

- V_{FG} Voltage on the (-) side of PC352 and C084
 (Same with the voltage between 7 (+) and 4 (-) of CNMF)
- V_{CC} Voltage between the C084 pins
 15 VDC
 (Same with the voltage between 5 (+) and 4 (-) of CNMF)
- V_{sp} Voltage between the C351 pins
 0VDC (with the fan stopped)
 1 - 6.5VDC (with the fan in operation)
 (Same with the voltage between 6 (+) and 4 (-) of CNMF)

5. Dipswitch setting (Factory setting)

1. Function setting

(1) SW1

Switch position	Function	Switch setting	
		ON	OFF
1	Active Thermistor (Intake air thermistor)	Built-in thermistor on the remote controller	Indoor unit
2	Filter clogging detection	Available	Unavailable
3	Filter life	2500 hr	100 hr
4	Outdoor air intake	Enabled	Disabled
5	Remote display	Thermo-ON signal	Fan output
6	Drainpump locking detection	Disabled	Enabled
7	Fan speed	Low	Very low
8	Fan speed at heating Thermo-OFF	Preset fan speed	Follows the setting of SW1-7
9	Auto restart after power failure	Enabled	Disabled
10	Power start/stop	Enabled	Disabled

Factory setting

PEFY-M·VMA(2)-A



PEFY-M·VMAL-A

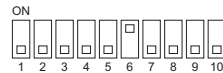

(2) SW3

Switch position	Function	Switch setting	
		ON	OFF
1	Unit type	Cooling only	Heat pump
2	-	-	-
3	-	-	-
4	-	-	-
5	-	-	-
6	-	-	-
7	-	-	-
8	Heating 4-deg up	Disabled	Enabled
9	-	-	-
10	-	-	-

Dipswitch settings must be made while the unit is stopped.

Factory setting

PEFY-M20VMA(L)-A



PEFY-M25, 40, 63, 71, 80, 100, 125, 140VMA(L)-A
PEFY-M20, 25, 32, 40, 50, 63, 71, 80, 100, 125VMA2-A



PEFY-M32, 50VMA(L)-A



The figure at left shows that the switches 1 through 5 are set to ON and 6 through 10 are set to OFF.

2. Capacity code setting

(1) SW2

Dipswitch settings must be made while the unit is stopped.

Factory setting

The switches are set to correspond to the unit capacity.

PEFY-M20VMA(L)(2)-A

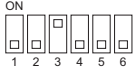

PEFY-M25VMA(L)(2)-A



PEFY-M32VMA(L)(2)-A



PEFY-M40VMA(L)(2)-A

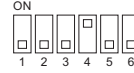

PEFY-M50VMA(L)(2)-A

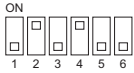

PEFY-M63VMA(L)(2)-A

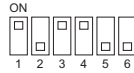

PEFY-M71VMA(L)(2)-A

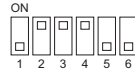

PEFY-M80VMA(L)(2)-A



PEFY-M100VMA(L)(2)-A

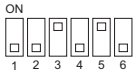

PEFY-M125VMA(L)(2)-A



PEFY-M140VMA(L)-A



The figure at left shows that the switches 1 through 5 are set to ON and 6 through 10 are set to OFF.

3. Model setting

(1) SW4

Dipswitch settings must be made while the unit is stopped.

Factory setting

Please see the WIRING LABEL on the control box.

Note:

Changes made to the dipswitches SW1, SW2, and SW3 will become effective when the unit comes to a stop (remote controller off). There is no need to power cycle the unit.

4. Power voltage setting

(1) SW21-6

Dipswitch settings must be operated with the main power turned OFF.

Factory setting

Please see the WIRING LABEL on the control box.

Set SW21-6 to OFF side when the power supply is 240 volts.

When the power supply is 220 and 230 volts, set SW21-6 to ON side.

5. External static pressure

Five levels of external static pressure are available for selection.

Set the setting either by using the switches on the control board (SW21-1, SW21-2, and SW21-5) or from the function selection screen on the remote controller.

Note:

◆When the static pressure setting was set from the remote controller, the actual setting and the switch setting on the control board may not match because the latest setting from the remote controller overrides the previous setting. To check the latest static pressure setting, check it on the remote controller, not on the switch.

◆If the static pressure setting for the duct is lower than that for the unit, the fan of the unit may repeat start/stop, and the outdoor unit may remain in a stopped state. Match the static pressure settings for the unit to that for the duct.

To set the external static pressure with the switches on the control board

External static pressure	SW21-1	SW21-2	SW21-5	Initial setting
M20–M63VMA-A: 35 Pa M71–M140VMA-A: 40 Pa M20–M32VMA2-A: 35 Pa M40–M125VMA2-A: 40 Pa	OFF	OFF	OFF	○ only M20–M100VMA-A, M20–M40VMA2-A
50 Pa	ON	OFF	OFF	○ only M125, M140VMA-A, M50–125VMA2-A
70 Pa	OFF	ON	ON	
100 Pa	OFF	OFF	ON	
150 Pa	ON	OFF	ON	

To set the external static pressure from the function selection screen on the remote controller (PAR-33MAA, PAR-40MAA)

Follow the instructions below and the instructions detailed in the remote controller manual for how to set the switches.

1. Set the function setting No. 32 (Switch setting/Function selection) to “2”.
2. Set the function setting No. 8 and No. 10 to appropriate values, according to the external static pressure.

Selection	Function setting No.	Initial setting	Current setting
	No. 32		
Switch setting	1	○	
Function selection	2		

External static pressure	Function setting No.		Initial setting	Current setting
	No. 8	No. 10		
M20–M63VMA-A: 35 Pa M71–M140VMA-A: 40 Pa M20–M32VMA2-A: 35 Pa M40–M125VMA2-A: 40 Pa	2	1	○ only M20–M100VMA-A, M20–M40VMA2-A	
50 Pa	3	1	○ only M125, M140VMA-A, M50–125VMA2-A	
70 Pa	1	2		
100 Pa	2	2		
150 Pa	3	2		

[Important]
Be sure to write down the settings for all functions in the “Current setting” row if any of the initial settings has been changed.

6. 1s and 10ths digits

- (1) SW11, SW12 (Rotary switch)

The use of an ME remote controller requires address setting.

Address settings must be made while the unit is stopped.

Factory setting

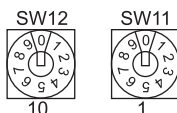

7. Connection No. setting

- (1) SW14 (Rotary switch)

This switch is used when the unit connected to an R2 series of outdoor unit.

Factory setting



Note:

Changes to the dipswitches SW11, SW12, SW14, and SW15 must be made while the unit is stopped and the remote controller is OFF.

[1] Disassembly Procedure

1. Control box

Exercise caution when removing heavy parts.

1. Removing the control box cover
 - (1) Remove the three fixing screws on the cover (A) to remove it.

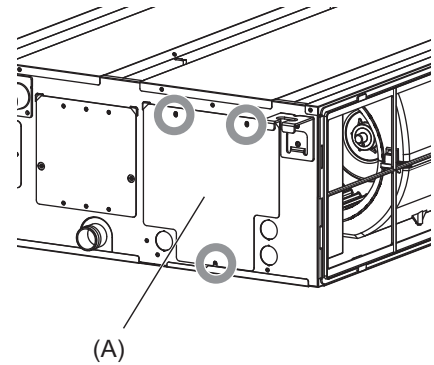

Fig.1

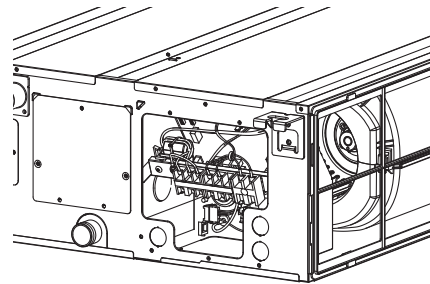

Fig.2

2. Thermistor (Intake air)

Exercise caution when removing heavy parts.

1. Remove the control box cover according to the procedure in section [1]-1.
2. Remove the thermistor.
 - (1) Pull out the thermistor holder (B) and thermistor (C) on the control box.

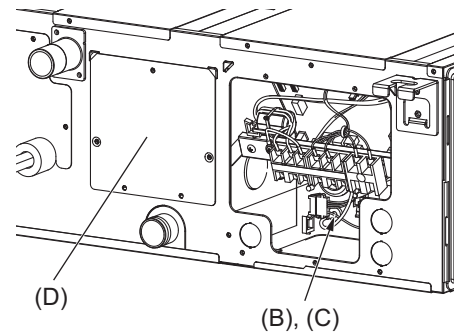

Fig.3

3. Drain pump

Exercise caution when removing heavy parts.

1. Remove the control box cover according to the procedure in section [1]-1.
2. Remove the drain pump.
 - (1) Remove the drain pump from connector (E) in control box.
 - (2) Remove the cover (D) and the drain pump.

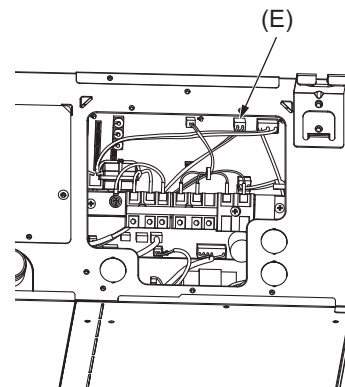

Fig.4

4. Drainpan

Exercise caution when removing heavy parts.

1. Removing the filter and the bottom plate
 - (1) Push down the tab on the filter, and pull out the filter in the direction of the arrow 1.
 - (2) Remove the fixing screws on the bottom plate (F), (G) to remove it.

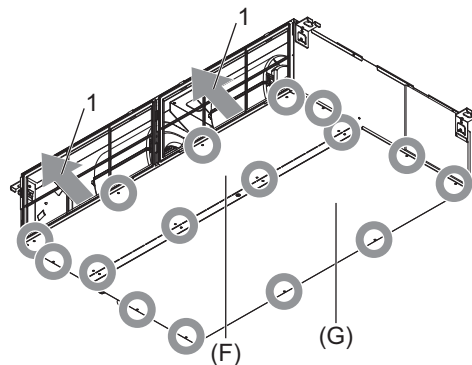

Fig.5

2. Removing the drainpan
 - (1) Pull out the drain pan in the direction of the arrow 2.

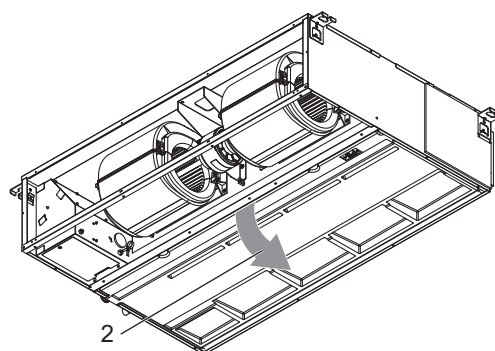

Fig.6

Note
•Drain the water out of the drain pan before removing it.

5. Thermistor (Gas pipe) (Liquid pipe)

Exercise caution when removing heavy parts.

1. Remove the drain pan according to the procedure in section [1]-4.
2. Removing the Heat exchanger cover
 - (1) Remove the three fixing screws on the heat exchanger cover (H) to remove it.

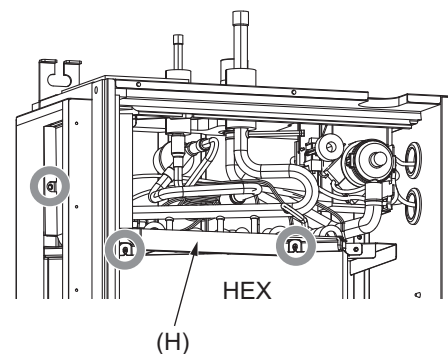

Fig.7

3. Removing the thermistor
 - (1) Remove the thermistor (J) from the thermistor holder (K) on the copper tube.

Thermistor size
Liquid pipe: $\varnothing 8\text{mm}$
Gas pipe: $\varnothing 6\text{mm}$

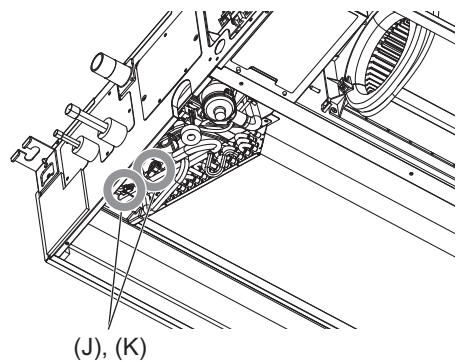

Fig.8

6. Fan and fan motor

Exercise caution when removing heavy parts.

1. Removing the filter and the bottom plate
 - (1) Push down the tab on the filter, and pull out the filter in the direction of the arrow 1.
 - (2) Remove the fixing screws on the bottom plate (M) to remove it.

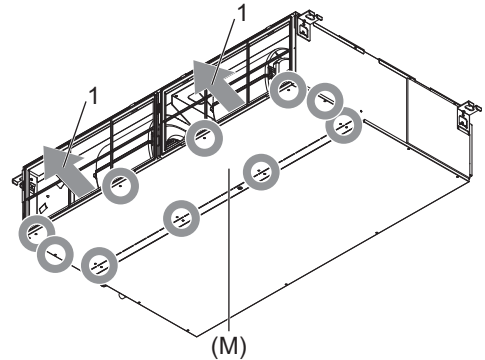

Fig.9

2. Removing the fan casing (bottom half)
 - (1) Squeeze the tabs on the fan casing to remove it in the direction of arrow 2.

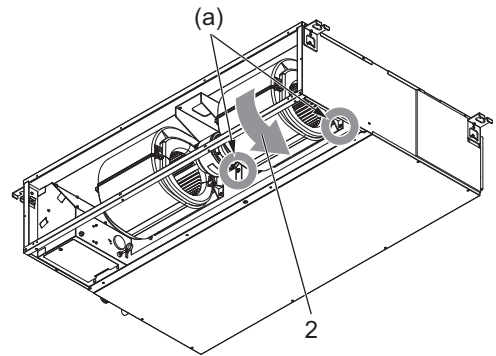

Fig.10

(a) Tab

3. Removing the motor cable
 - (1) Remove the motor cable through the rubber bush.
4. Removing the fan motor and the Sirocco fan
 - (1) Loosen either of the two rubber joint (N) fixing screws.
 - (2) To remove the Sirocco fans (b) and (c) of PEFY-M100/125/140VMA(L)-A, PEFY-M100/125VMA2-A, loosen only the screw (d) on the bearing support (P), and remove the other screws on it.

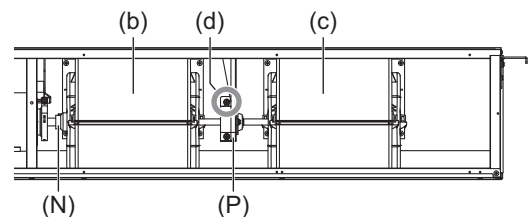

Fig.11

- (3) Remove the two motor fixing screws to remove the motor and the Sirocco fan in the direction of arrow 3.

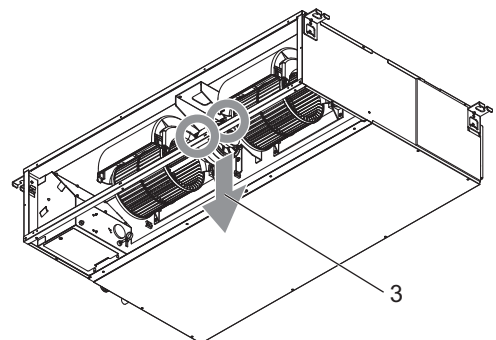

Fig.12

- (4) Remove the four fan case fixing screws to take the top half of the fan casing off.

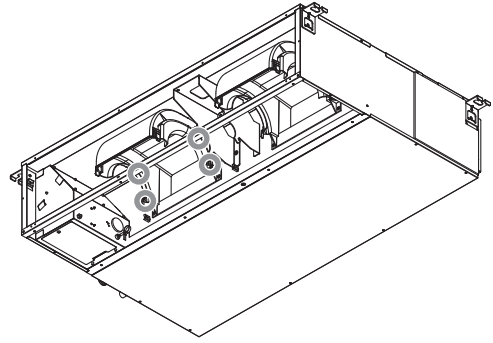

Fig.13

7. Heat exchanger

Exercise caution when removing heavy parts.

1. Remove the drain pan according to the procedure in section [1]-4.
2. Remove the heat exchanger cover according to the procedure in section [1]-5-2.
3. Removing the cover
 - (1) Remove the five fixing screws on the cover (Q) to remove it.

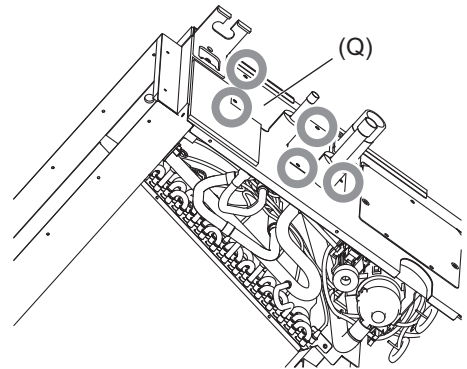

Fig.14

4. Removing the Heat exchanger
 - (1) Remove the fixing screws on the heat exchanger (R) to remove it.

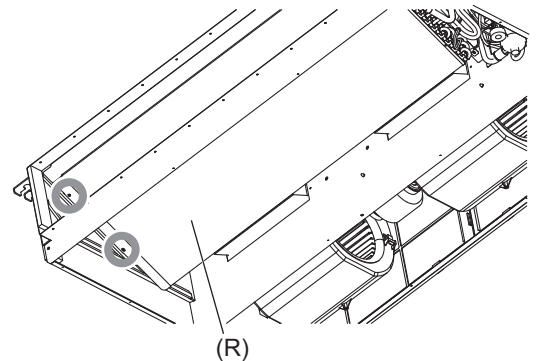

Fig.15

mitsubishi electric corporation

www.MitsubishiElectric.com
