

2010

R410A

Service Handbook

Model

PUHY-P200, P250, P300, P350YHA

PUHY-P400, P450YHA

PUHY-P500, P550, P600, P650YSHA

PUHY-P700, P750, P800, P850, P900YSHA

PUHY-P950, P1000, P1050, P1100, P1150, P1200, P1250YSHA

Safety Precautions

- Before installing the unit, thoroughly read the following safety precautions.
- Observe these safety precautions for your safety.

WARNING

This symbol is intended to alert the user to the presence of important instructions that must be followed to avoid the risk of serious injury or death.

CAUTION

This symbol is intended to alert the user to the presence of important instructions that must be followed to avoid the risk of serious injury or damage to the unit.

- After reading this manual, give it to the user to retain for future reference.
- Keep this manual for easy reference. When the unit is moved or repaired, give this manual to those who provide these services.
When the user changes, make sure that the new user receives this manual.

WARNING

Ask your dealer or a qualified technician to install the unit.

Improper installation by the user may result in water leakage, electric shock, smoke, and/or fire.

Properly install the unit on a surface that can withstand the weight of the unit.

Unit installed on an unstable surface may fall and cause injury.

Only use specified cables. Securely connect each cable so that the terminals do not carry the weight of the cable.

Improperly connected or fixed cables may produce heat and start a fire.

Take appropriate safety measures against strong winds and earthquakes to prevent the unit from falling.

If the unit is not installed properly, the unit may fall and cause serious injury to the person or damage to the unit.

Do not make any modifications or alterations to the unit. Consult your dealer for repair.

Improper repair may result in water leakage, electric shock, smoke, and/or fire.

Do not touch the heat exchanger fins.

The fins are sharp and dangerous.

In the event of a refrigerant leak, thoroughly ventilate the room.

If refrigerant gas leaks and comes in contact with an open flame, poisonous gases will be produced.

When installing the All-Fresh type units, take it into consideration that the outside air may be discharged directly into the room when the thermo is turned off.

Direct exposure to outdoor air may have an adverse effect on health. It may also result in food spoilage.

Properly install the unit according to the instructions in the installation manual.

Improper installation may result in water leakage, electric shock, smoke, and/or fire.

Have all electrical work performed by an authorized electrician according to the local regulations and instructions in this manual, and a dedicated circuit must be used.

Insufficient capacity of the power supply circuit or improper installation may result in malfunctions of the unit, electric shock, smoke, and/or fire.

 **WARNING**

Securely attach the terminal block cover (panel) to the unit.

If the terminal block cover (panel) is not installed properly, dust and/or water may infiltrate and pose a risk of electric shock, smoke, and/or fire.

Only use the type of refrigerant that is indicated on the unit when installing or reinstalling the unit.

Infiltration of any other type of refrigerant or air into the unit may adversely affect the refrigerant cycle and may cause the pipes to burst or explode.

When installing the unit in a small room, exercise caution and take measures against leaked refrigerant reaching the limiting concentration.

Consult your dealer with any questions regarding limiting concentrations and for precautionary measures before installing the unit. Leaked refrigerant gas exceeding the limiting concentration causes oxygen deficiency.

Consult your dealer or a specialist when moving or reinstalling the unit.

Improper installation may result in water leakage, electric shock, and/or fire.

After completing the service work, check for a gas leak.

If leaked refrigerant is exposed to a heat source, such as a fan heater, stove, or electric grill, poisonous gases may be produced.

Do not try to defeat the safety features of the unit.

Forced operation of the pressure switch or the temperature switch by defeating the safety features of these devices, or the use of accessories other than the ones that are recommended by MITSUBISHI may result in smoke, fire, and/or explosion.

Only use accessories recommended by MITSUBISHI.

Ask a qualified technician to install the unit. Improper installation by the user may result in water leakage, electric shock, smoke, and/or fire.

Control box houses high-voltage parts.

When opening or closing the front panel of the control box, do not let it come into contact with any of the internal components. Before inspecting the inside of the control box, turn off the power, keep the unit off for at least 10 minutes, and confirm that the voltage between FT-P and FT-N on INV Board has dropped to DC20V or less. (It takes about 10 minutes to discharge electricity after the power supply is turned off.)

Precautions for handling units for use with R410A

CAUTION

Do not use the existing refrigerant piping.

- ♦A large amount of chlorine that may be contained in the residual refrigerant and refrigerating machine oil in the existing piping may cause the refrigerating machine oil in the new unit to deteriorate.
- ♦R410A is a high-pressure refrigerant and can cause the existing pipes to burst.

Use refrigerant pipes made of phosphorus deoxidized copper. Keep the inner and outer surfaces of the pipes clean and free of such contaminants as sulfur, oxides, dust, dirt, shaving particles, oil, and water.

These types of contaminants inside the refrigerant pipes may cause the refrigerant oil to deteriorate.

Store the pipes to be installed indoors, and keep both ends of the pipes sealed until immediately before brazing. (Keep elbows and other joints wrapped in plastic.)

Infiltration of dust, dirt, or water into the refrigerant system may cause the refrigerating machine oil to deteriorate or cause the unit to malfunction.

Use a small amount of ester oil, ether oil, or alkylbenzene to coat flares and flanges.

Infiltration of a large amount of mineral oil may cause the refrigerating machine oil to deteriorate.

Charge liquid refrigerant (as opposed to gaseous refrigerant) into the system.

If gaseous refrigerant is charged into the system, the composition of the refrigerant in the cylinder will change and may result in performance loss.

Use a vacuum pump with a reverse-flow check valve.

If a vacuum pump that is not equipped with a reverse-flow check valve is used, the vacuum pump oil may flow into the refrigerant cycle and cause the refrigerating machine oil to deteriorate.

Prepare tools for exclusive use with R410A. Do not use the following tools if they have been used with the conventional refrigerant (gauge manifold, charging hose, gas leak detector, reverse-flow check valve, refrigerant charge base, vacuum gauge, and refrigerant recovery equipment.).

- ♦If the refrigerant or the refrigerating machine oil left on these tools are mixed in with R410A, it may cause the refrigerating machine oil to deteriorate.
- ♦Infiltration of water may cause the refrigerating machine oil to deteriorate.
- ♦Gas leak detectors for conventional refrigerants will not detect an R410A leak because R410A is free of chlorine.

Do not use a charging cylinder.

If a charging cylinder is used, the composition of the refrigerant will change, and the unit may experience power loss.

Exercise special care when handling the tools for use with R410A.

Infiltration of dust, dirt, or water into the refrigerant system may cause the refrigerating machine oil to deteriorate.

Only use refrigerant R410A.

The use of other types of refrigerant that contain chlorine (i.e. R22) may cause the refrigerating machine oil to deteriorate.

Before installing the unit

WARNING

Do not install the unit where a gas leak may occur.

If gaseous refrigerant leaks and piles up around the unit, it may be ignited.

Do not use the unit to keep food items, animals, plants, artifacts, or for other special purposes.

The unit is not designed to preserve food products.

Do not use the unit in an unusual environment.

- ♦ Do not install the unit where a large amount of oil or steam is present or where acidic or alkaline solutions or chemical sprays are used frequently. Doing so may lead to a remarkable drop in performance, electric shock, malfunctions, smoke, and/or fire.
- ♦ The presence of organic solvents or corrosive gas (i.e. ammonia, sulfur compounds, and acid) may cause gas leakage or water leakage.

When installing the unit in a hospital, take appropriate measures to reduce noise interference.

High-frequency medical equipment may interfere with the normal operation of the air conditioner or vice versa.

Do not install the unit on or over things that cannot get wet.

When the humidity level exceeds 80% or if the drainage system is clogged, the indoor unit may drip water. Drain water is also discharged from the outdoor unit. Install a centralized drainage system if necessary.

Before installing the unit (moving and reinstalling the unit) and performing electrical work

CAUTION

Properly ground the unit.

Do not connect the grounding wire to a gas pipe, water pipe, lightning rod, or grounding wire from a telephone pole. Improper grounding may result in electric shock, smoke, fire, and/or malfunction due to noise interference.

Do not put tension on the power supply wires.

If tension is put on the wires, they may break and result in excessive heat, smoke, and/or fire.

Install an earth leakage breaker to avoid the risk of electric shock.

Failure to install an earth leakage breaker may result in electric shock, smoke, and/or fire.

Use the kind of power supply wires that are specified in the installation manual.

The use of wrong kind of power supply wires may result in current leak, electric shock, and/or fire.

Use breakers and fuses (current breaker, remote switch <switch + Type-B fuse>, moulded case circuit breaker) with the proper current capacity.

The use of wrong capacity fuses, steel wires, or copper wires may result in malfunctions, smoke, and/or fire.

Do not spray water on the air conditioner or immerse the air conditioner in water.

Otherwise, electric shock and/or fire may result.

When handling units, always wear protective gloves to protect your hands from metal parts and high-temperature parts.

Periodically check the installation base for damage.

If the unit is left on a damaged platform, it may fall and cause injury.

Properly install the drain pipes according to the instructions in the installation manual. Keep them insulated to avoid dew condensation.

Improper plumbing work may result in water leakage and damage to the furnishings.

Exercise caution when transporting products.

- ♦ Products weighing more than 20 kg should not be carried alone.
- ♦ Do not carry the product by the PP bands that are used on some products.
- ♦ Do not touch the heat exchanger fins. They are sharp and dangerous.
- ♦ When lifting the unit with a crane, secure all four corners to prevent the unit from falling.

Properly dispose of the packing materials.

- ♦ Nails and wood pieces in the package may pose a risk of injury.
- ♦ Plastic bags may pose a risk of choking hazard to children. Tear plastic bags into pieces before disposing of them.

Before the test run

 **CAUTION**

Turn on the unit at least 12 hours before the test run.

Keep the unit turned on throughout the season. If the unit is turned off in the middle of a season, it may result in malfunctions.

To avoid the risk of electric shock or malfunction of the unit, do not operate switches with wet hands.

Do not touch the refrigerant pipes with bare hands during and immediately after operation.

During or immediately after operation, certain parts of the unit such as pipes and compressor may be either very cold or hot, depending on the state of the refrigerant in the unit at the time. To reduce the risk of frost bites and burns, do not touch these parts with bare hands.

Do not operate the unit without panels and safety guards.

Rotating, high-temperature, or high-voltage parts on the unit pose a risk of burns and/or electric shock.

Do not turn off the power immediately after stopping the operation.

Keep the unit on for at least five minutes before turning off the power to prevent water leakage or malfunction.

Do not operate the unit without the air filter.

Dust particles may build up in the system and cause malfunctions.

CONTENTS

I Read Before Servicing

| | |
|---|----|
| [1] Read Before Servicing | 3 |
| [2] Necessary Tools and Materials | 4 |
| [3] Piping Materials | 5 |
| [4] Storage of Piping | 7 |
| [5] Pipe Processing | 7 |
| [6] Brazing | 8 |
| [7] Air Tightness Test | 9 |
| [8] Vacuum Drying (Evacuation) | 10 |
| [9] Refrigerant Charging | 11 |
| [10] Remedies to be taken in case of a Refrigerant Leak | 11 |
| [11] Characteristics of the Conventional and the New Refrigerants | 12 |
| [12] Notes on Refrigerating Machine Oil | 13 |

II Restrictions

| | |
|---|----|
| [1] System configuration | 17 |
| [2] Types and Maximum allowable Length of Cables | 18 |
| [3] Switch Settings and Address Settings | 19 |
| [4] Sample System Connection | 26 |
| [5] An Example of a System to which an MA Remote Controller is connected | 28 |
| [6] An Example of a System to which an ME Remote Controller is connected | 38 |
| [7] An Example of a System to which both MA Remote Controller and ME Remote Controller are connected | 40 |
| [8] Restrictions on Pipe Length | 42 |

III Outdoor Unit Components

| | |
|---|----|
| [1] Outdoor Unit Components and Refrigerant Circuit | 49 |
| [2] Control Box of the Outdoor Unit | 51 |
| [3] Outdoor Unit Circuit Board | 52 |

IV Remote Controller

| | |
|--|----|
| [1] Functions and Specifications of MA and ME Remote Controllers | 59 |
| [2] Group Settings and Interlock Settings via the ME Remote Controller | 60 |
| [3] Interlock Settings via the MA Remote Controller | 64 |
| [4] Using the built-in Temperature Sensor on the Remote Controller | 65 |

V Electrical Wiring Diagram

| | |
|---|----|
| [1] Electrical Wiring Diagram of the Outdoor Unit | 69 |
| [2] Electrical Wiring Diagram of Transmission Booster | 70 |

VI Refrigerant Circuit

| | |
|---|----|
| [1] Refrigerant Circuit Diagram | 73 |
| [2] Principal Parts and Functions | 74 |

VII Control

| | |
|---|-----|
| [1] Functions and Factory Settings of the Dipswitches | 81 |
| [2] Controlling the Outdoor Unit | 87 |
| [3] Operation Flow Chart | 100 |

VIII Test Run Mode

| | |
|---|-----|
| [1] Items to be checked before a Test Run | 107 |
| [2] Test Run Method | 108 |
| [3] Operating Characteristic and Refrigerant Amount | 109 |
| [4] Adjusting the Refrigerant Amount | 109 |
| [5] Refrigerant Amount Adjust Mode | 112 |
| [6] The following symptoms are normal | 114 |
| [7] Standard Operation Data (Reference Data) | 115 |

IX Troubleshooting

| | |
|--|-----|
| [1] Error Code Lists | 155 |
| [2] Responding to Error Display on the Remote Controller | 158 |
| [3] Investigation of Transmission Wave Shape/Noise | 219 |
| [4] Troubleshooting Principal Parts | 222 |
| [5] Refrigerant Leak | 242 |
| [6] Compressor Replacement Instructions | 244 |
| [7] Troubleshooting Using the Outdoor Unit LED Error Display | 246 |

X LED Monitor Display on the Outdoor Unit Board

| | |
|--|-----|
| [1] How to Read the LED on the Service Monitor | 249 |
|--|-----|



I Read Before Servicing

| | |
|---|----|
| [1] Read Before Servicing | 3 |
| [2] Necessary Tools and Materials..... | 4 |
| [3] Piping Materials | 5 |
| [4] Storage of Piping | 7 |
| [5] Pipe Processing | 7 |
| [6] Brazing..... | 8 |
| [7] Air Tightness Test..... | 9 |
| [8] Vacuum Drying (Evacuation) | 10 |
| [9] Refrigerant Charging..... | 11 |
| [10] Remedies to be taken in case of a Refrigerant Leak..... | 11 |
| [11] Characteristics of the Conventional and the New Refrigerants | 12 |
| [12] Notes on Refrigerating Machine Oil..... | 13 |



[1] Read Before Servicing

1. Check the type of refrigerant used in the system to be serviced.

Refrigerant Type

Multi air conditioner for building application CITY MULTI YHA series R410A

2. Check the symptoms exhibited by the unit to be serviced.

Refer to this service handbook for symptoms relating to the refrigerant cycle.

3. Thoroughly read the safety precautions at the beginning of this manual.

4. Preparing necessary tools: Prepare a set of tools to be used exclusively with each type of refrigerant.

Refer to "Necessary Tools and Materials" for information on the use of tools.(page 4)

5. Verification of the connecting pipes: Verify the type of refrigerant used for the unit to be moved or replaced.

- Use refrigerant pipes made of phosphorus deoxidized copper. Keep the inner and outer surfaces of the pipes clean and free of such contaminants as sulfur, oxides, dust, dirt, shaving particles, oil, and water.
- These types of contaminants inside the refrigerant pipes may cause the refrigerant oil to deteriorate.

6. If there is a leak of gaseous refrigerant and the remaining refrigerant is exposed to an open flame, a poisonous gas hydrofluoric acid may form. Keep workplace well ventilated.



CAUTION

- Install new pipes immediately after removing old ones to keep moisture out of the refrigerant circuit.
- The use of refrigerant that contains chloride, such as R22, will cause the refrigerating machine oil to deteriorate.

[2] Necessary Tools and Materials

Prepare the following tools and materials necessary for installing and servicing the unit.

Tools for use with R410A (Adaptability of tools that are for use with R22 or R407C)

1. To be used exclusively with R410A (not to be used if used with R22 or R407C)

| Tools/Materials | Use | Notes |
|---|---------------------------------------|---|
| Gauge Manifold | Evacuation and refrigerant charging | Higher than 5.09MPa[738psi] on the high-pressure side |
| Charging Hose | Evacuation and refrigerant charging | The hose diameter is larger than the conventional model. |
| Refrigerant Recovery Cylinder | Refrigerant recovery | |
| Refrigerant Cylinder | Refrigerant charging | The refrigerant type is indicated. The cylinder is pink. |
| Charging Port on the Refrigerant Cylinder | Refrigerant charging | The charge port diameter is larger than that of the current port. |
| Flare Nut | Connection of the unit with the pipes | Use Type-2 Flare nuts. |

2. Tools and materials that may be used with R410A with some restrictions

| Tools/Materials | Use | Notes |
|--------------------------------|----------------------|--|
| Gas Leak Detector | Gas leak detection | The ones for use with HFC refrigerant may be used. |
| Vacuum Pump | Vacuum drying | May be used if a check valve adapter is attached. |
| Flare Tool | Flare processing | Flare processing dimensions for the piping in the system using the new refrigerant differ from those of R22. Refer to next page. |
| Refrigerant Recovery Equipment | Refrigerant recovery | May be used if compatible with R410A. |

3. Tools and materials that are used with R22 or R407C that may also be used with R410A

| Tools/Materials | Use | Notes |
|--------------------------------|-----------------------|---|
| Vacuum Pump with a Check Valve | Vacuum drying | |
| Bender | Bending pipes | |
| Torque Wrench | Tightening flare nuts | Only the flare processing dimensions for pipes that have a diameter of $\phi 12.70$ (1/2") and $\phi 15.88$ (5/8") have been changed. |
| Pipe Cutter | Cutting pipes | |
| Welder and Nitrogen Cylinder | Welding pipes | |
| Refrigerant Charging Meter | Refrigerant charging | |
| Vacuum Gauge | Vacuum level check | |

4. Tools and materials that must not be used with R410A

| Tools/Materials | Use | Notes |
|-------------------|----------------------|-------------------|
| Charging Cylinder | Refrigerant charging | Prohibited to use |

Tools for R410A must be handled with special care to keep moisture and dust from infiltrating the cycle.

[3] Piping Materials

Do not use the existing piping!

1. Copper pipe materials

| | |
|-----------------------|--|
| O-material (Annealed) | Soft copper pipes (annealed copper pipes). They can easily be bent with hands. |
| 1/2H-material (Drawn) | Hard copper pipes (straight pipes). They are stronger than the O-material (Annealed) at the same radial thickness. |

- The distinction between O-materials (Annealed) and 1/2H-materials (Drawn) is made based on the strength of the pipes themselves.
- O-materials (Annealed) can easily be bent with hands.
- 1/2H-materials (Drawn) are considerably stronger than O-material (Annealed) at the same thickness.

2. Types of copper pipes

| | |
|--------------------------|------------------|
| Maximum working pressure | Refrigerant type |
| 3.45 MPa [500psi] | R22, R407C etc. |
| 4.30 MPa [624psi] | R410A etc. |

3. Piping materials/Radial thickness

Use refrigerant pipes made of phosphorus deoxidized copper.
 The operation pressure of the units that use R410A is higher than that of the units that use R22.
 Use pipes that have at least the radial thickness specified in the chart below.
 (Pipes with a radial thickness of 0.7 mm or less may not be used.)

| Pipe size (mm[in]) | Radial thickness (mm) | Type |
|--------------------|-----------------------|--------------------------------------|
| ø6.35 [1/4"] | 0.8t | O-material (Annealed) |
| ø9.52 [3/8"] | 0.8t | |
| ø12.7 [1/2"] | 0.8t | |
| ø15.88 [5/8"] | 1.0t | |
| ø19.05 [3/4"] | 1.0t | 1/2H-material, H-material (Drawn) |
| ø22.2 [7/8"] | 1.0t | |
| ø25.4 [1"] | 1.0t | |
| ø28.58 [1-1/8"] | 1.0t | |
| ø31.75 [1-1/4"] | 1.1t | |
| ø34.93 [1-3/8"] | 1.1t | |
| ø41.28 [1-5/8"] | 1.2t | |

- The pipes in the system that uses the refrigerant currently on the market are made with O-material (Annealed), even if the pipe diameter is less than ø19.05 (3/4"). For a system that uses R410A, use pipes that are made with 1/2H-material (Drawn) unless the pipe diameter is at least ø19.05 (3/4") and the radial thickness is at least 1.2t.
- The figures in the radial thickness column are based on the Japanese standards and provided only as a reference. Use pipes that meet the local standards.

4. Thickness and refrigerant type indicated on the piping materials

Ask the pipe manufacturer for the symbols indicated on the piping material for new refrigerant.

5. Flare processing (O-material (Annealed) and OL-material only)

The flare processing dimensions for the pipes that are used in the R410A system are larger than those in the R22 system.

Flare processing dimensions (mm[in])

| Pipe size (mm[in]) | A dimension (mm) | |
|--------------------|------------------|------------|
| | R410A | R22, R407C |
| ø6.35 [1/4"] | 9.1 | 9.0 |
| ø9.52 [3/8"] | 13.2 | 13.0 |
| ø12.7 [1/2"] | 16.6 | 16.2 |
| ø15.88 [5/8"] | 19.7 | 19.4 |
| ø19.05 [3/4"] | 24.0 | 23.3 |

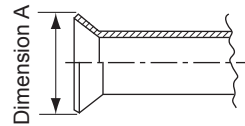

If a clutch-type flare tool is used to flare the pipes in the system using R410A, the length of the pipes must be between 1.0 and 1.5 mm. For margin adjustment, a copper pipe gauge is necessary.

6. Flare nut

The flare nut type has been changed to increase the strength. The size of some of the flare nuts have also been changed.

Flare nut dimensions (mm[in])

| Pipe size (mm[in]) | B dimension (mm) | |
|----------------------|------------------|-------------|
| | R410A | R22, R407C |
| ø6.35 [1/4"] | 17.0 | 17.0 |
| ø9.52 [3/8"] | 22.0 | 22.0 |
| ø12.7 [1/2"] | 26.0 | 24.0 |
| ø15.88 [5/8"] | 29.0 | 27.0 |
| ø19.05 [3/4"] | 36.0 | 36.0 |

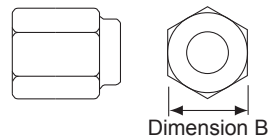

The figures in the radial thickness column are based on the Japanese standards and provided only as a reference. Use pipes that meet the local standards.

[4] Storage of Piping

1. Storage location



Store the pipes to be used indoors. (Warehouse at site or owner's warehouse)
If they are left outdoors, dust, dirt, or moisture may infiltrate and contaminate the pipe.

2. Sealing the pipe ends

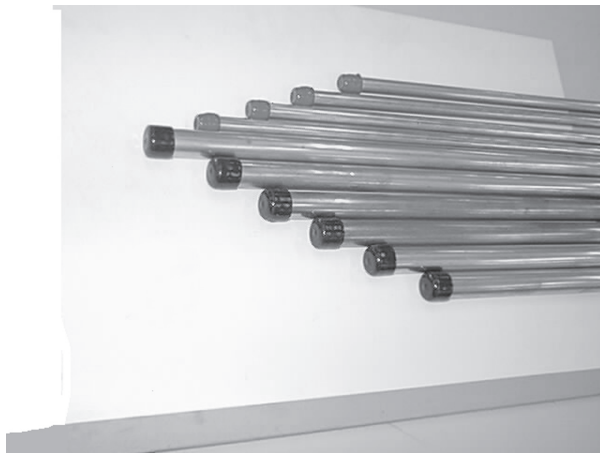

Both ends of the pipes should be sealed until just before brazing.
Keep elbow pipes and T-joints in plastic bags.

The new refrigerator oil is 10 times as hygroscopic as the conventional refrigerating machine oil (such as Suniso) and, if not handled with care, could easily introduce moisture into the system. Keep moisture out of the pipes, for it will cause the oil to deteriorate and cause a compressor failure.

[5] Pipe Processing

Use a small amount of ester oil, ether oil, or alkylbenzene to coat flares and flanges.

Note

- Use a minimum amount of oil.
- Use only ester oil, ether oil, and alkylbenzene.

[6] Brazing

No changes have been made in the brazing procedures. Perform brazing with special care to keep foreign objects (such as oxide scale, water, and dust) out of the refrigerant system.

Example: Inside the brazed connection

Use of oxidized solder for brazing

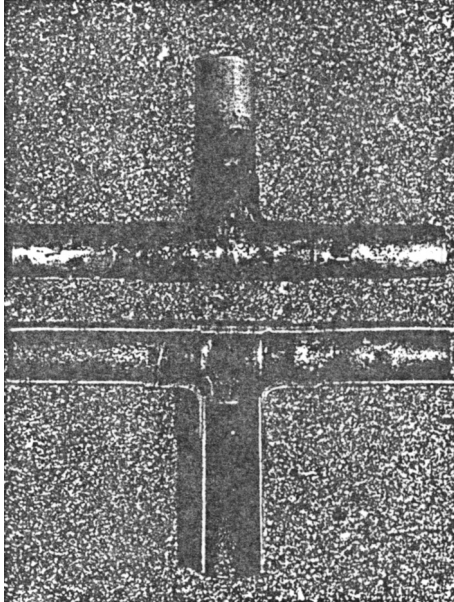

Use of non-oxidized solder for brazing

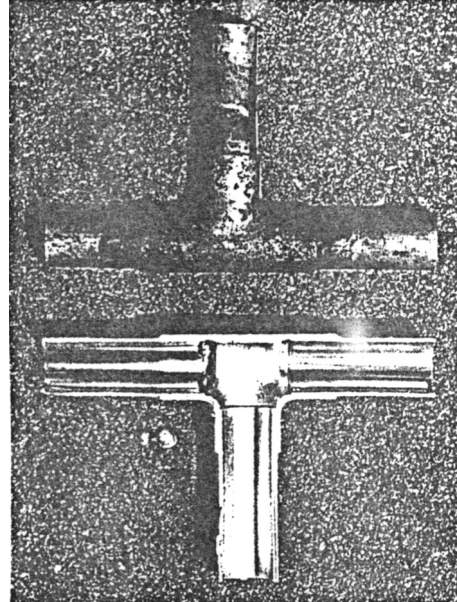

1. Items to be strictly observed

- Do not conduct refrigerant piping work outdoors if raining.
- Use non-oxidized solder.
- Use a brazing material (BCuP-3) that requires no flux when brazing between copper pipes or between a copper pipe and copper coupling.
- If installed refrigerant pipes are not immediately connected to the equipment, then braze and seal both ends.

2. Reasons

- The new refrigerating machine oil is 10 times as hygroscopic as the conventional oil and is more likely to cause unit failure if water infiltrates into the system.
- Flux generally contains chloride. Residual flux in the refrigerant circuit will cause sludge to form.

3. Notes

Do not use commercially available antioxidants because they may cause the pipes to corrode or refrigerating machine oil to deteriorate.

[7] Air Tightness Test

No changes have been made in the detection method. Note that a refrigerant leak detector for R22 will not detect an R410A leak.

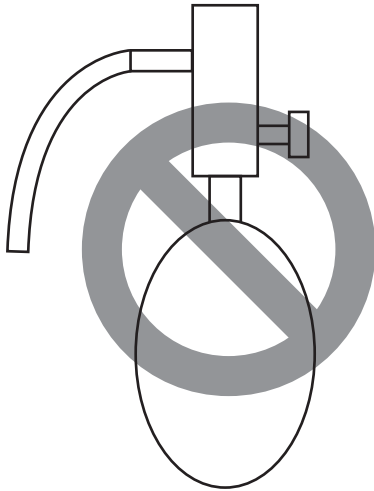

Halide torch

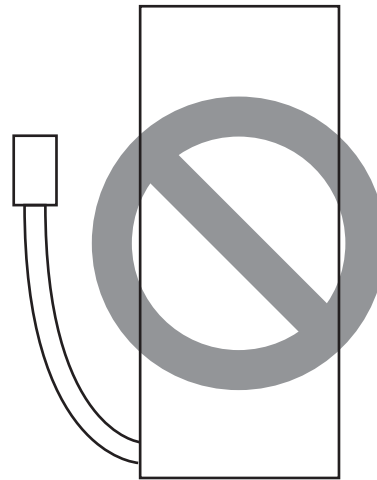

R22 leakage detector

1. Items to be strictly observed

- Pressurize the equipment with nitrogen up to the design pressure (4.15MPa[601psi]), and then judge the equipment's air tightness, taking temperature variations into account.
- Refrigerant R410A must be charged in its liquid state (vs. gaseous state).

2. Reasons

- Oxygen, if used for an air tightness test, poses a risk of explosion. (Only use nitrogen to check air tightness.)
- Refrigerant R410A must be charged in its liquid state. If gaseous refrigerant in the cylinder is drawn out first, the composition of the remaining refrigerant in the cylinder will change and become unsuitable for use.

3. Notes

Procure a leak detector that is specifically designed to detect an HFC leak. A leak detector for R22 will not detect an HFC(R410A) leak.

[8] Vacuum Drying (Evacuation)



(Photo1) 15010H



(Photo2) 14010

Recommended vacuum gauge:
ROBINAIR 14010 Thermistor Vacuum Gauge

1. Vacuum pump with a reverse-flow check valve (Photo1)

To prevent the vacuum pump oil from flowing into the refrigerant circuit during power OFF or power failure, use a vacuum pump with a reverse-flow check valve.
A reverse-flow check valve may also be added to the vacuum pump currently in use.

2. Standard of vacuum degree (Photo 2)

Use a vacuum pump that attains 0.5Torr(65Pa) or lower degree of vacuum after 5 minutes of operation, and connect it directly to the vacuum gauge. Use a pump well-maintained with an appropriate lubricant. A poorly maintained vacuum pump may not be able to attain the desired degree of vacuum.

3. Required precision of vacuum gauge

Use a vacuum gauge that registers a vacuum degree of 5Torr(650Pa) and measures at intervals of 1Torr(130Pa). (A recommended vacuum gauge is shown in Photo2.)
Do not use a commonly used gauge manifold because it cannot register a vacuum degree of 5Torr(650Pa).

4. Evacuation time

- After the degree of vacuum has reached 5Torr(650Pa), evacuate for an additional 1 hour. (A thorough vacuum drying removes moisture in the pipes.)
- Verify that the vacuum degree has not risen by more than 1Torr(130Pa) 1hour after evacuation. A rise by less than 1Torr(130Pa) is acceptable.
- If the vacuum is lost by more than 1Torr(130Pa), conduct evacuation, following the instructions in section 6. Special vacuum drying.

5. Procedures for stopping vacuum pump

To prevent the reverse flow of vacuum pump oil, open the relief valve on the vacuum pump side, or draw in air by loosening the charge hose, and then stop the operation.
The same procedures should be followed when stopping a vacuum pump with a reverse-flow check valve.

6. Special vacuum drying

- When 5Torr(650Pa) or lower degree of vacuum cannot be attained after 3 hours of evacuation, it is likely that water has penetrated the system or that there is a leak.
- If water infiltrates the system, break the vacuum with nitrogen. Pressurize the system with nitrogen gas to 0.5kgf/cm²G(0.05MPa) and evacuate again. Repeat this cycle of pressurizing and evacuation either until the degree of vacuum below 5Torr(650Pa) is attained or until the pressure stops rising.
- Only use nitrogen gas for vacuum breaking. (The use of oxygen may result in an explosion.)

[9] Refrigerant Charging

Cylinder with a siphon

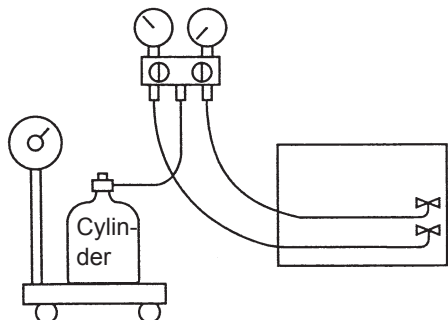

Cylinder color R410A is pink.

Cylinder without a siphon

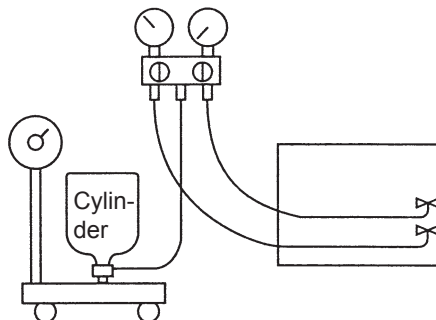

Refrigerant charging in the liquid state

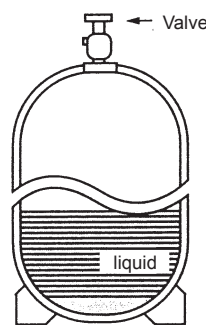
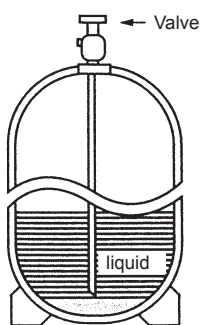

1. Reasons

R410A is a pseudo-azeotropic HFC blend (boiling point R32=-52°C[-62°F], R125=-49°C[-52°F]) and can almost be handled the same way as a single refrigerant, such as R22. To be safe, however, draw out the refrigerant from the cylinder in the liquid phase. If the refrigerant in the gaseous phase is drawn out, the composition of the remaining refrigerant will change and become unsuitable for use.

2. Notes

When using a cylinder with a siphon, refrigerant is charged in the liquid state without the need for turning it upside down. Check the type of the cylinder on the label before use.

[10] Remedies to be taken in case of a Refrigerant Leak

If the refrigerant leaks out, it may be replenished. The entire refrigerant does not need to be replaced. (Charge refrigerant in the liquid state.)

Refer to "IX [5] Refrigerant Leak".(page 242)

[11] Characteristics of the Conventional and the New Refrigerants

1. Chemical property

As with R22, the new refrigerant (R410A) is low in toxicity and chemically stable nonflammable refrigerant. However, because the specific gravity of vapor refrigerant is greater than that of air, leaked refrigerant in a closed room will accumulate at the bottom of the room and may cause hypoxia. If exposed to an open flame, refrigerant will generate poisonous gases. Do not perform installation or service work in a confined area.

| | New Refrigerant (HFC type) | | Conventional Refrigerant (HCFC type) |
|--|--|--|---|
| | R410A | R407C | R22 |
| | R32/R125 | R32/R125/R134a | R22 |
| Composition (wt%) | (50/50) | (23/25/52) | (100) |
| Type of Refrigerant | Pseudo-azeotropic Refrigerant | Non-azeotropic Refrigerant | Single Refrigerant |
| Chloride | Not included | Not included | Included |
| Safety Class | A1/A1 | A1/A1 | A1 |
| Molecular Weight | 72.6 | 86.2 | 86.5 |
| Boiling Point (°C/°F) | -51.4/-60.5 | -43.6/-46.4 | -40.8/-41.4 |
| Steam Pressure (25°C,MPa/77°F,psi) (gauge) | 1.557/226 | 0.9177/133 | 0.94/136 |
| Saturated Steam Density (25°C,kg/m ³ /77°F,psi) | 64.0 | 42.5 | 44.4 |
| Flammability | Nonflammable | Nonflammable | Nonflammable |
| Ozone Depletion Coefficient (ODP)^{*1} | 0 | 0 | 0.055 |
| Global Warming Coefficient (GWP) ^{*2} | 1730 | 1530 | 1700 |
| Refrigerant Charging Method | Refrigerant charging in the liquid state | Refrigerant charging in the liquid state | Refrigerant charging in the gaseous state |
| Replenishment of Refrigerant after a Refrigerant Leak | Available | Available | Available |

*1 When CFC11 is used as a reference

*2 When CO₂ is used as a reference

2. Refrigerant composition

R410A is a pseudo-azeotropic HFC blend and can almost be handled the same way as a single refrigerant, such as R22. To be safe, however, draw out the refrigerant from the cylinder in the liquid phase. If the refrigerant in the gaseous phase is drawn out, the composition of the remaining refrigerant will change and become unsuitable for use. If the refrigerant leaks out, it may be replenished. The entire refrigerant does not need to be replaced.

3. Pressure characteristics

The pressure in the system using R410A is 1.6 times as great as that in the system using R22.

| Temperature (°C/°F) | Pressure (gauge) | | |
|---------------------|------------------|----------|----------|
| | R410A | R407C | R22 |
| | MPa/psi | MPa/psi | MPa/psi |
| -20/-4 | 0.30/44 | 0.18/26 | 0.14/20 |
| 0/32 | 0.70/102 | 0.47/68 | 0.40/58 |
| 20/68 | 1.34/194 | 0.94/136 | 0.81/117 |
| 40/104 | 2.31/335 | 1.44/209 | 1.44/209 |
| 60/140 | 3.73/541 | 2.44/354 | 2.33/338 |
| 65/149 | 4.17/605 | 2.75/399 | 2.60/377 |

[12] Notes on Refrigerating Machine Oil

1. Refrigerating machine oil in the HFC refrigerant system

HFC type refrigerants use a refrigerating machine oil different from that used in the R22 system. Note that the ester oil used in the system has properties that are different from commercially available ester oil.

| Refrigerant | Refrigerating machine oil |
|-------------|---------------------------|
| R22 | Mineral oil |
| R407C | Ester oil |
| R410A | Ester oil |

2. Effects of contaminants*1

Refrigerating machine oil used in the HFC system must be handled with special care to keep contaminants out. The table below shows the effect of contaminants in the refrigerating machine oil on the refrigeration cycle.

3. The effects of contaminants in the refrigerating machine oil on the refrigeration cycle.

| Cause | | Symptoms | Effects on the refrigerant cycle |
|------------------------------|------------------|--|---|
| Water infiltration | | Frozen expansion valve and capillary tubes | Clogged expansion valve and capillary tubes Poor cooling performance Compressor overheat Motor insulation failure Burnt motor Coppering of the orbiting scroll Lock Burn-in on the orbiting scroll |
| | | Hydrolysis Sludge formation and adhesion Acid generation Oxidization Oil degradation | |
| Air infiltration | | Oxidization | |
| Infiltration of contaminants | Dust, dirt | Adhesion to expansion valve and capillary tubes | Clogged expansion valve, capillary tubes, and drier Poor cooling performance Compressor overheat |
| | | Infiltration of contaminants into the compressor | Burn-in on the orbiting scroll |
| | Mineral oil etc. | Sludge formation and adhesion | Clogged expansion valve and capillary tubes Poor cooling performance Compressor overheat |
| | | Oil degradation | Burn-in on the orbiting scroll |

*1. Contaminants is defined as moisture, air, processing oil, dust/dirt, wrong types of refrigerant, and refrigerating machine oil.

II Restrictions

| | |
|--|----|
| [1] System configuration | 17 |
| [2] Types and Maximum allowable Length of Cables | 18 |
| [3] Switch Settings and Address Settings | 19 |
| [4] Sample System Connection..... | 26 |
| [5] An Example of a System to which an MA Remote Controller is connected..... | 28 |
| [6] An Example of a System to which an ME Remote Controller is connected..... | 38 |
| [7] An Example of a System to which both MA Remote Controller and ME Remote Controller are connected..... | 40 |
| [8] Restrictions on Pipe Length..... | 42 |



[1] System configuration

1. Table of compatible indoor units

The table below summarizes the types of indoor units that are compatible with different types of outdoor units.

(1) Standard combinations

| Outdoor units | Composing units | | | Maximum total capacity of connectable indoor units | Maximum number of connectable indoor units | Types of connectable indoor units |
|---------------|-----------------|------|------|--|--|--|
| P200 | - | - | - | 100 - 260 | 17 | P15 - P200 models R410A series indoor units |
| P250 | - | - | - | 125 - 325 | 21 | |
| P300 | - | - | - | 150 - 390 | 26 | |
| P350 | - | - | - | 175 - 455 | 30 | P15 - P400 models R410A series indoor units |
| P400 | - | - | - | 200 - 520 | 34 | P15 - P500 models R410A series indoor units |
| P450 | - | - | - | 225 - 585 | 39 | |
| P500 | P250 | P250 | - | 250 - 650 | 43 | |
| P550 | P300 | P250 | - | 275 - 715 | 47 | |
| P600 | P350 | P250 | - | 300 - 780 | 50 | |
| P650 | P350 | P300 | - | 325 - 845 | | |
| P700 | P350 | P350 | - | 350 - 910 | | |
| P750 | P400 | P350 | - | 375 - 975 | | |
| P800 | P450 | P350 | - | 400 - 1040 | | |
| P850 | P450 | P400 | - | 425 - 1105 | | |
| P900 | P450 | P450 | - | 450 - 1170 | | |
| P950 | P400 | P300 | P250 | 475 - 1235 | | |
| P1000 | P400 | P300 | P300 | 500 - 1300 | | |
| P1050 | P400 | P350 | P300 | 525 - 1365 | | |
| P1100 | P400 | P350 | P350 | 550 - 1430 | | |
| P1150 | P450 | P350 | P350 | 575 - 1495 | | |
| P1200 | P450 | P400 | P350 | 600 - 1560 | | |
| P1250 | P450 | P450 | P350 | 625 - 1625 | | |

Note

- 1) "Maximum total capacity of connectable indoor units" refers to the sum of the numeric values in the indoor unit model names.
- 2) If the total capacity of the indoor units that are connected to a given outdoor unit exceeds the capacity of the outdoor unit, the indoor units will not be able to perform at the rated capacity when they are operated simultaneously. Select a combination of units so that the total capacity of the connected indoor units is at or below the capacity of the outdoor unit whenever possible.

[2] Types and Maximum allowable Length of Cables

1. Wiring work

(1) Notes

- 1) Have all electrical work performed by an authorized electrician according to the local regulations and instructions in this manual.
- 2) Install external transmission cables at least 5cm [1-31/32"] away from the power supply cable to avoid noise interference. (Do not put the control cable and power supply cable in the same conduit tube.)
- 3) Provide grounding for the outdoor unit as required.
- 4) Run the cable from the electric box of the indoor or outdoor unit in such way that the box is accessible for servicing.
- 5) Do not connect power supply wiring to the terminal block for transmission line. Doing so will damage the electronic components on the terminal block.
- 6) Use 2-core shielded cables as transmission cables.

Use a separate 2-core control cable for each refrigerant system. Do not use a single multiple-core cable to connect indoor units that belong to different refrigerant systems. The use of a multiple-core cable may result in signal transmission errors and malfunctions.

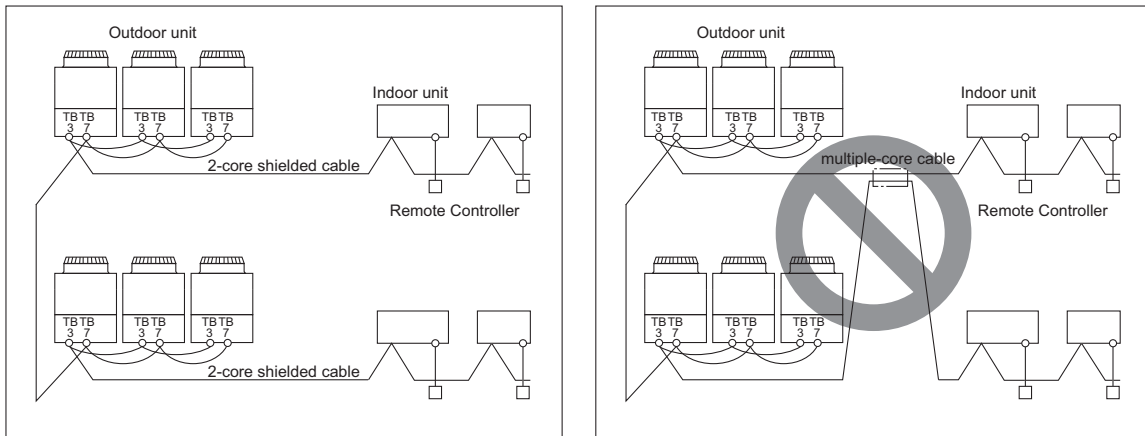

TB3: Terminal block for indoor-outdoor transmission line TB7: Terminal block for centralized control

(2) Control wiring

Different types of control wiring are used for different systems.

Refer to section "[5] An Example of a System to which an MA Remote Controller is connected - [7] An Example of a System to which both MA Remote Controller and ME Remote Controller are connected" before performing wiring work.

Types and maximum allowable length of cables

Control lines are categorized into 2 types: transmission line and remote controller line.

Use the appropriate type of cables and observe the maximum allowable length specified for a given system. If a given system has a long transmission line or if a noise source is located near the unit, place the unit away from the noise source to reduce noise interference.

1) M-NET transmission line

| | | |
|--|-----------------|--|
| Cable type | Facility type | All facility types |
| | Type | Shielded cable CVVS, CPEVS, MVVS |
| | Number of cores | 2-core cable |
| | Cable size | Larger than 1.25mm ² [AWG16] |
| Maximum transmission line distance between the outdoor unit and the farthest indoor unit | | 200 m [656ft] max. |
| Maximum transmission line distance for centralized control and Indoor/outdoor transmission line (Maximum line distance via outdoor unit) | | 500 m [1640ft] max. *The maximum overall line length from the power supply unit on the transmission lines for centralized control to each outdoor unit or to the system controller is 200m [656ft] max. |

2) Remote controller wiring

| | | MA remote controller ^{*1} | ME remote controller ^{*2} |
|-----------------------------|-----------------|--|---|
| Cable type | Type | CVV | CVV |
| | Number of cores | 2-core cable | 2-core cable |
| | Cable size | 0.3 to 1.25mm ² ^{*3} [AWG22 to 16] (0.75 to 1.25mm ²) ^{*4} [AWG18 to 16] | 0.3 to 1.25mm ² ^{*3} [AWG22 to 16] (0.75 to 1.25mm ²) ^{*4} [AWG18 to 16] |
| Maximum overall line length | | 200 m [656ft] max. | The section of the cable that exceeds 10m [32ft] must be included in the maximum indoor-outdoor transmission line distance. |

*1 MA remote controller refers to MA remote controller (PAR-20MAA, PAR-21MAA), MA simple remote controller, and wireless remote controller.

*2 ME remote controller refers to ME remote controller and ME simple remote controller.

*3 The use of cables that are smaller than 0.75mm² (AWG18) is recommended for easy handling.

*4 When connected to the terminal block on the Simple remote controller, use cables that meet the cable size specifications shown in the parenthesis.

[3] Switch Settings and Address Settings

1. Switch setting

Refer to section "[5] An Example of a System to which an MA Remote Controller is connected - [7] An Example of a System to which both MA Remote Controller and ME Remote Controller are connected" before performing wiring work.

Set the switches while the power is turned off.

If the switch settings are changed while the unit is being powered, those changes will not take effect, and the unit will not function properly.

| Units on which to set the switches | | Symbol | Units to which the power must be shut off |
|---|----------------------------|------------|---|
| CITY MULTI indoor unit | Main/sub unit | IC | Outdoor units ^{*3} and Indoor units |
| LOSSNAY, OA processing unit ^{*1} | | LC | Outdoor units ^{*3} and LOSSNAY |
| Air handling kit | | IC | Outdoor units ^{*3} or field supplied air handling unit |
| ME remote controller | Main/sub remote controller | RC | Outdoor units ^{*3} |
| MA remote controller | Main/sub remote controller | MA | Indoor units |
| CITY MULTI outdoor unit ^{*2} | | OC,OS1,OS2 | Outdoor units ^{*3} |

*1. Applicable when LOSSNAY units are connected to the indoor-outdoor transmission line.

*2. The outdoor units in the same refrigerant circuit are automatically designated as OC, OS1, and OS2 in the order of capacity from large to small (if two or more units have the same capacity, in the order of address from small to large).

*3. Turn off the power to all the outdoor units in the same refrigerant circuit.

2. M-NET Address settings

(1) Address settings table

The need for address settings and the range of address setting depend on the configuration of the system.

| Unit or controller | | Address setting range | Setting method | Factory setting |
|---|--|--|---|-----------------|
| CITY MULTI indoor unit | Main/sub unit | 00, 01 to 50* ¹ | Assign the smallest address to the main indoor unit in the group, and assign sequential address numbers to the rest of the indoor units in the same group. ⁴ | 00 |
| M-NET adapter | | | | |
| M-NET control interface | | | | |
| Free Plan adapter | | | | |
| LOSSNAY, OA processing unit Air handling kit | | 00, 01 to 50* ¹ | Assign an arbitrary but unique address to each of these units after assigning an address to all indoor units. | 00 |
| ME remote controller | Main remote controller | 101 to 150 | Add 100 to the smallest address of all the indoor units in the same group. | 101 |
| | Sub remote controller | 151 to 200* ² | Add 150 to the smallest address of all the indoor units in the same group. | |
| MA remote controller | | No address settings required. (The main/sub setting must be made if 2 remote controllers are connected to the system.) | | Main |
| CITY MULTI outdoor unit | | 00, 51 to 100* ^{1,3} | Assign sequential addresses to the outdoor units in the same refrigerant circuit. The outdoor units in the same refrigerant circuit are automatically designated as OC and OS. ⁵ | 00 |
| System controller | Group remote controller | 201 to 250 | Assign an address that equals the sum of the smallest group number of the group to be controlled and 200. | 201 |
| | System remote controller | | Assign an arbitrary but unique address within the range listed on the left to each unit. | |
| | ON/OFF remote controller | | Assign an address that equals the sum of the smallest group number of the group to be controlled and 200. | |
| | Schedule timer (compatible with M-NET) | Assign an arbitrary but unique address within the range listed on the left to each unit. | 202 | |
| | Central controller G(B)-50A | 000, 201 to 250 | Assign an arbitrary but unique address within the range listed on the left to each unit. The address must be set to "000" to control the K-control unit. | 000 |
| | LM adapter | 201 to 250 | Assign an arbitrary but unique address within the range listed on the left to each unit. | 247 |

*1. Address setting is not required for a City Multi system that consists of a single refrigerant circuit (with some exceptions).

*2. To set the ME remote controller address to "200", set the rotary switches to "00".

*3. To set the outdoor unit address to "100," set the rotary switches to "50."

*4. Some indoor units have 2 or 3 controller boards that require address settings.

No. 2 controller board address must be equal to the sum of the No. 1 controller board address and 1, and the No.3 controller board address must equal to the No. 1 controller address and 2.

*5. The outdoor units in the same refrigerant circuit are automatically designated as OC, OS1, and OS2 in the order of capacity from large to small (if two or more units have the same capacity, in the order of address from small to large).

**(2) Power supply switch connector connection on the outdoor unit
(Factory setting: The male power supply switch connector is connected to CN41.)**

| System configuration | Connection to the system controller | Power supply unit for transmission lines | Group operation of units in a system with multiple outdoor units | Power supply switch connector connection |
|------------------------------------|---|--|--|--|
| System with one outdoor unit | – | – | – | Leave CN41 as it is (Factory setting) |
| System with multiple outdoor units | Not connected | – | Not grouped | Disconnect the male connector from the female power supply switch connector (CN41) and connect it to the female power supply switch connector (CN40) on only one of the outdoor units.* ² *Connect the S (shielded) terminal on the terminal block (TB7) on the outdoor unit whose CN41 was replaced with CN40 to the ground terminal (⌈) on the electric box. |
| | | | Grouped | |
| | With connection to the indoor unit system | Not required | Grouped/not grouped | |
| | | | With connection to the centralized control system | |
| | Required* ¹ | Grouped/not grouped | Leave CN41 as it is (Factory setting) | |

*1 The need for a power supply unit for transmission lines depends on the system configuration.

*2 The replacement of the power jumper connector from CN41 to CN40 must be performed on only one outdoor unit in the system.

(3) Settings for the centralized control switch for the outdoor unit (Factory setting: SW2-1 are set to OFF.)

| System configuration | Centralized control switch settings* ¹ |
|---|---|
| Connection to the system controller Not connected | Leave it to OFF. (Factory setting) |
| Connection to the system controller Connected* ² | ON |

*1 Set SW2-1 on all outdoor units in the same refrigerant circuit to the same setting.

*2 When only the LM adapter is connected, leave SW2-1 to OFF (as it is).

(4) Selecting the position of temperature detection for the indoor unit (Factory setting: SW1-1 set to "OFF".)

To stop the fan during heating Thermo-OFF (SW1-7 and 1-8 on the indoor units to be set to ON), use the built-in thermistor on the remote controller or an optional thermistor.

1) To use the built-in sensor on the remote controller, set the SW1-1 to ON.

•Some models of remote controllers are not equipped with a built-in temperature sensor.

Use the built-in temperature sensor on the indoor unit instead.

•When using the built-in sensor on the remote controller, install the remote controller where room temperature can be detected.

(Note) Factory setting for SW1-1 on the indoor unit of the All-Fresh Models is ON.

2) When an optional temperature sensor is used, set SW1-1 to OFF, and set SW3-8 to ON.

•When using an optional temperature sensor, install it where room temperature can be detected.

(5) Various start-stop controls (Indoor unit settings)

Each indoor unit (or group of indoor units) can be controlled individually by setting SW 1-9 and 1-10.

| Function | Operation of the indoor unit when the operation is resumed after the unit was stopped | Setting (SW1)* ⁴ * ⁵ | |
|--|---|--|-----|
| | | 9 | 10 |
| Power ON/OFF by the plug* ^{1,2,3} | Indoor unit will go into operation regardless of its operation status before power off (power failure). (In approx. 5 minutes) | OFF | ON |
| Automatic restoration after power failure | Indoor unit will go into operation if it was in operation when the power was turned off (or cut off due to power failure). (In approx. 5 minutes) | ON | OFF |
| | Indoor unit will remain stopped regardless of its operation status before power off (power failure). | OFF | ON |

*1. Do not cut off power to the outdoor unit. Cutting off the power supply to the outdoor unit will cut off the power supply to the crankcase heater and may cause the compressor to malfunction when the unit is put back into operation.

*2. Not applicable to units with a built-in drain pump or humidifier.

*3. Models with a built-in drain pump cannot be turned on/off by the plug individually. All the units in the same refrigerant circuits will be turned on or off by the plug.

*4. Requires that the dipswitch settings for all the units in the group be made.

*5. To control the external input to and output from the air conditioners with the PLC software for general equipment via the G(B)-50A, set SW1-9 and SW1-10 to ON. With these settings made, the power start-stop function becomes disabled. To use the auto recovery function after power failure while these settings are made, set SW1-5 to ON.

(6) Miscellaneous settings

Cooling-only setting for the indoor unit: Cooling only model (Factory setting: SW3-1 "OFF.")
 When using indoor unit as a cooling-only unit, set SW3-1 to ON.

(7) Various types of control using input-output signal connector on the outdoor unit (various connection options)

| Type | Usage | Function | Terminal to be used ^{*1} | Option |
|---------|--|--|-----------------------------------|--|
| Input | Prohibiting cooling/heating operation (thermo OFF) by an external input to the outdoor unit. *It can be used as the DEMAND control device for each system. | DEMAND (level) | CN3D ^{*2} | Adapter for external input (PAC-SC36NA-E) |
| | Performs a low level noise operation of the outdoor unit by an external input to the outdoor unit. * It can be used as the silent operation device for each refrigerant system. | Low-noise mode (level) ^{*3*4} | | |
| | Forces the outdoor unit to perform a fan operation by receiving signals from the snow sensor. ^{*5} | Snow sensor signal input (level) | CN3S | |
| | Cooling/heating operation can be changed by an external input to the outdoor unit. | Auto-changeover | CN3N | |
| Out-put | How to extract signals from the outdoor unit *It can be used as an operation status display device. *It can be used for an interlock operation with external devices. | Operation status of the compressor | CN51 | Adapter for external output (PAC-SC37SA-E) |
| | | Error status | | |

- *1. For detailed drawing, refer to "Example of wiring connection".
- *2. For details, refer to (1) through (4) shown below.
- *3. Low-noise mode is valid when Dip SW4-4 on the outdoor unit is set to OFF. When DIP SW4-4 is set to ON, 4 levels of on-DEMAND are possible, using different configurations of low-noise mode input and DEMAND input settings. When 2 or more outdoor units exist in one refrigerant circuit system, 8 levels of on-DEMAND are possible. When 3 outdoor units exist in one refrigerant circuit system, 12 levels of on-DEMAND are possible.
- *4. By setting Dip SW5-5, the Low-noise mode can be switched between the Capacity priority mode and the Low-noise priority mode.
 When SW5-5 is set to ON: The Low-noise mode always remains effective.
 When SW5-5 is set to OFF: The Low-noise mode is cancelled when certain outside temperature or pressure criteria are met, and the unit goes into normal operation (capacity priority mode).

| Low-noise mode is effective | | Capacity priority mode becomes effective | |
|--|---|---|--|
| Cooling | Heating | Cooling | Heating |
| TH7 < 30°C [86°F] and 63HS1 < 32kg/cm ² | TH7 > 3°C [37°F] and 63LS > 4.6kg/cm ² | TH7 > 35°C [95°F] or 63HS1 > 35kg/cm ² | TH7 < 0°C [32°F] or 63LS < 3.9kg/cm ² |

- *5. When multiple outdoor units exist in one refrigerant circuit system, settings on every outdoor unit (signal input) are required.

⚠ CAUTION

- 1) Wiring should be covered by insulation tube with supplementary insulation.
- 2) Use relays or switches with IEC or equivalent standard.
- 3) The electric strength between accessible parts and control circuit should have 2750V or more.

Example of wiring connection

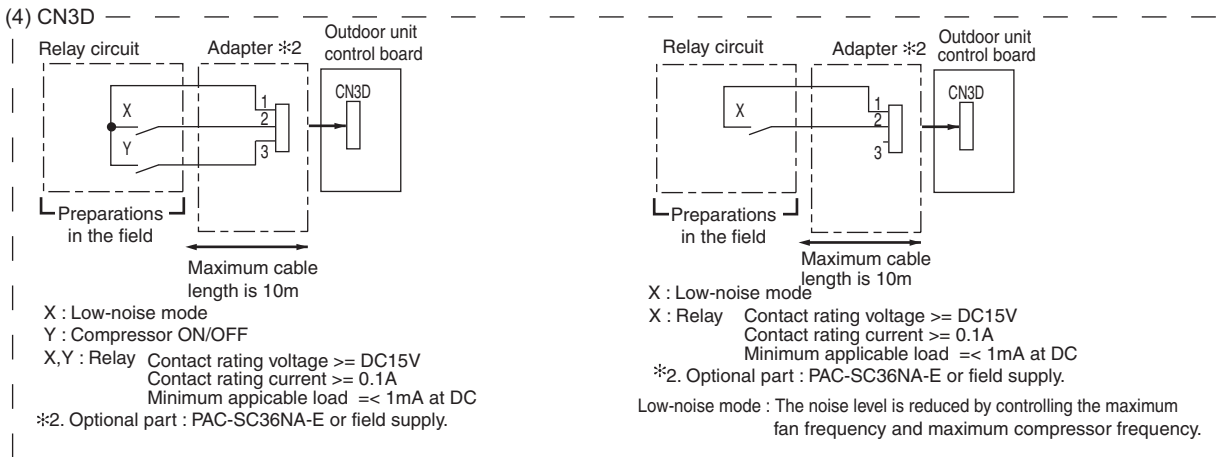
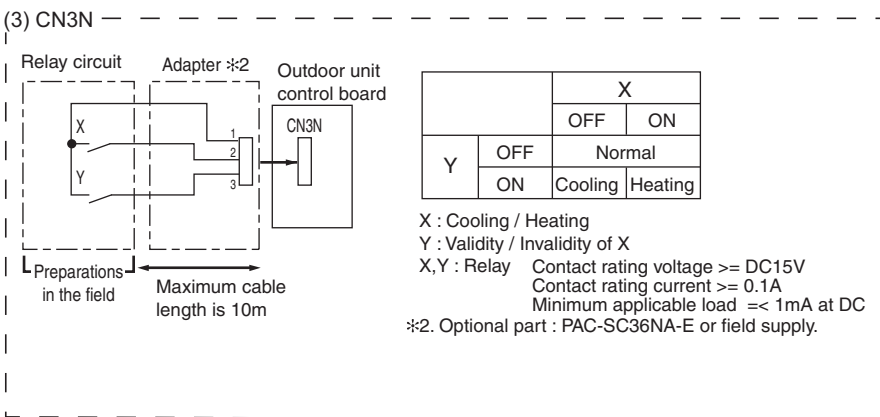
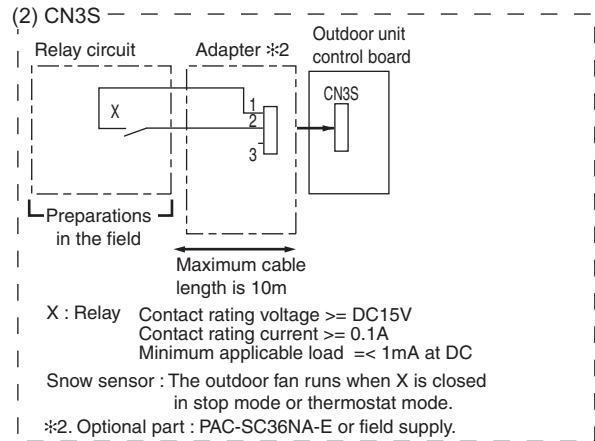
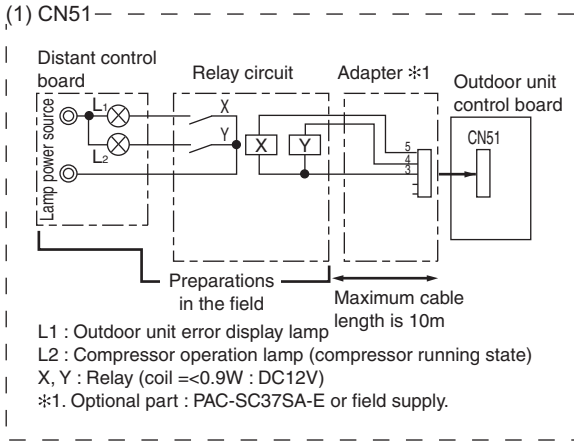

1. Demand control

(1) General outline of control

Demand control is performed by using the external signal input to the 1-2 and 1-3 pins of CN3D on the outdoor units (OC, OS1, and OS2).

Between 2 and 12 steps of demand control is possible by setting DIP SW4-4 on the outdoor units (OC, OS1, and OS2).

Table.1

| No | Demand control switch | DipSW4-4 | | | Input to CN3D *2 |
|-----|--|----------|-----|-----|------------------|
| | | OC | OS1 | OS2 | |
| (a) | 2 steps(0-100%) | OFF | OFF | OFF | OC |
| (b) | 4 steps(0-50-75-100%) | ON | OFF | OFF | OC |
| (c) | | OFF | ON | OFF | OS1 |
| (d) | | OFF | OFF | ON | OS2 |
| (e) | 8 steps(0-25-38-50-63-75-88-100%) | ON | ON | OFF | OC and OS1 |
| (f) | | ON | OFF | ON | OC and OS2 |
| (g) | | OFF | ON | ON | OS1 and OS2 |
| (h) | 12 steps(0-17-25-34-42-50-59-67-75-84-92-100%) | ON | ON | ON | OC, OS1, and OS2 |

*1. Available demand functions

P200 - P450YHA models (single-outdoor-unit system): 2 and 4 steps shown in the rows (a) and (b) in the table above only.

P500 - P900YSHA models (two-outdoor-unit system OC+OS1): 2-8 steps shown in the rows (a), (b), (c), and (e) in the table above only.

P950 - P1250YSHA models (three-outdoor-unit system OC+OS1+OS2): 2-12 steps shown in the rows (a)-(h) in the table above.

*2. External signal is input to CN3D on the outdoor unit whose SW4-4 is set to ON. When SW4-4 is set to OFF on all outdoor units, the signal is input to the CN3D on the OC.

Outdoor units whose SW4-4 is set to ON are selectable in a single refrigerant system.

*3. If wrong sequence of steps are taken, the units may go into the Thermo-OFF (compressor stop) mode.

Ex) When switching from 100% to 50%

(Incorrect) 100% to 0% to 50% : The units may go into the Thermo-OFF mode.

(Correct) 100% to 75% to 50%

*4. The percentage of the demand listed in the table above is an approximate value based on the compressor volume and does not necessarily correspond with the actual capacity.

*5. Notes on using demand control in combination with the low-noise mode

To enable the low-noise mode, it is necessary to short-circuit 1-2 pin of CN3D on the outdoor unit whose SW4-4 is set to OFF.

When SW4-4 is set to ON on all outdoor units, the following operations cannot be performed.

- Performing 4-step demand in combination with the low-noise operation in a single-outdoor-unit system.
- Performing 8-step demand in combination with the low-noise operation in a two-outdoor-unit system.
- Performing 12-step demand in combination with the low-noise operation in a three-outdoor-unit system.

(2) Contact input and control content

1) 2-step demand control

- The same control as the Thermo-OFF is performed by closing 1-3 pin of CN3D.

| | |
|-------|----------|
| CN3D | |
| 1-3P | |
| Open | x = 100% |
| Close | x = 0% |

2) 4-step demand control (When SW4-4 is set to ON on an outdoor unit)

Demand capacity is shown below.

| | | |
|-------|----------|---------|
| CN3D | 1-2P | |
| 1-3P | Open | Close |
| Open | x = 100% | x = 75% |
| Close | x = 0% | x = 50% |

[II Restrictions]

3) 8-step demand control (When SW4-4 is set to ON on two outdoor units)

Demand capacity is shown below.

| 8-step demand | | No.2 CN3D | | | | |
|---------------|---------------|---------------|------|---------------|---------------|---------------|
| | | 1-2P | Open | | Short-circuit | |
| No.1 CN3D | 1-2P | 1-3P | Open | Short-circuit | Open | Short-circuit |
| | Open | Open | 100% | 50% | 88% | 75% |
| | | Short-circuit | 50% | 0% | 38% | 25% |
| | Short-circuit | Open | 88% | 38% | 75% | 63% |
| Short-circuit | | 75% | 25% | 63% | 50% | |

*1. The outdoor units whose SW4-4 is set to ON are designated as No. 1 and No. 2 in the order of address from small to large.
Ex) When outdoor units whose SW4-4 is set to ON are designated as OS1 and OS2, OS1=No. 1 and OS2=No. 2.

4) 12-step demand control (When SW4-4 is set to ON on three outdoor units)

Demand capacity is shown below.

| 12-step demand | No.2 CN3D | 1-2P | Open | | | | | | | |
|----------------|---------------|---------------|------|---------------|---------------|---------------|---------------|---------------|---------------|---------------|
| | | 1-3P | Open | | | | Short-circuit | | | |
| | No.3 CN3D | 1-2P | Open | | Short-circuit | | Open | | Short-circuit | |
| No.1 CN3D | 1-2P | 1-3P | Open | Short-circuit | Open | Short-circuit | Open | Short-circuit | Open | Short-circuit |
| | Open | Open | 100% | 67% | 92% | 84% | 67% | 34% | 59% | 50% |
| | | Short-circuit | 67% | 34% | 59% | 50% | 34% | 0% | 25% | 17% |
| | Short-circuit | Open | 92% | 59% | 84% | 75% | 59% | 25% | 50% | 42% |
| Short-circuit | | 84% | 50% | 75% | 67% | 50% | 17% | 42% | 34% | |

| 12-step demand | No.2 CN3D | 1-2P | Short-circuit | | | | | | | |
|----------------|---------------|---------------|---------------|---------------|---------------|---------------|---------------|---------------|---------------|---------------|
| | | 1-3P | Open | | | | Short-circuit | | | |
| | No.3 CN3D | 1-2P | Open | | Short-circuit | | Open | | Short-circuit | |
| No.1 CN3D | 1-2P | 1-3P | Open | Short-circuit | Open | Short-circuit | Open | Short-circuit | Open | Short-circuit |
| | Open | Open | 92% | 59% | 84% | 75% | 84% | 50% | 75% | 67% |
| | | Short-circuit | 59% | 25% | 50% | 42% | 50% | 17% | 42% | 34% |
| | Short-circuit | Open | 84% | 50% | 75% | 67% | 75% | 42% | 67% | 59% |
| Short-circuit | | 75% | 42% | 67% | 59% | 67% | 34% | 59% | 50% | |

*1. The outdoor units whose SW4-4 is set to ON are designated as No. 1, No. 2, and No. 3 in the order of address from small to large.
Ex) When outdoor units whose SW4-4 is set to ON are designated as OC, OS1, and OS2, OC=No. 1, OS1=No. 2, and OS2=No. 3.

[4] Sample System Connection

Examples of typical system connection are shown on pages [5] to [7].
Refer to the Installation Manual that came with each device or controller for details.

(1) An example of a system to which an MA remote controller is connected

| | System configuration | Connection to the system controller | Address start up for indoor and outdoor units | Notes |
|----|---|--|---|---------------------------------------|
| 1. | System with one outdoor unit | NO | Automatic address setup | |
| 2. | System with one outdoor unit | NO | Manual address setup | Connection of multiple LOSS-NAY units |
| 3. | Grouping of units in a system with multiple outdoor units | NO | Manual address setup | |
| 4. | System with one outdoor unit | With connection to transmission line for centralized control | Manual address setup | |
| 5. | System with one outdoor unit | With connection to indoor-outdoor transmission line | Manual address setup | |

(2) An example of a system to which an ME remote controller is connected

| | System configuration | Connection to the system controller | Address start up for indoor and outdoor units | Notes |
|----|------------------------------|--|---|-------|
| 1. | System with one outdoor unit | With connection to transmission line for centralized control | Manual address setup | |

(3) An example of a system to which both MA remote controller and ME remote controller are connected

| | System configuration | Connection to the system controller | Address start up for indoor and outdoor units | Notes |
|----|------------------------------|--|---|-------|
| 1. | System with one outdoor unit | With connection to transmission line for centralized control | Manual address setup | |

[5] An Example of a System to which an MA Remote Controller is connected

1. System with one outdoor unit (automatic address setup for both indoor and outdoor units)

(1) Sample control wiring

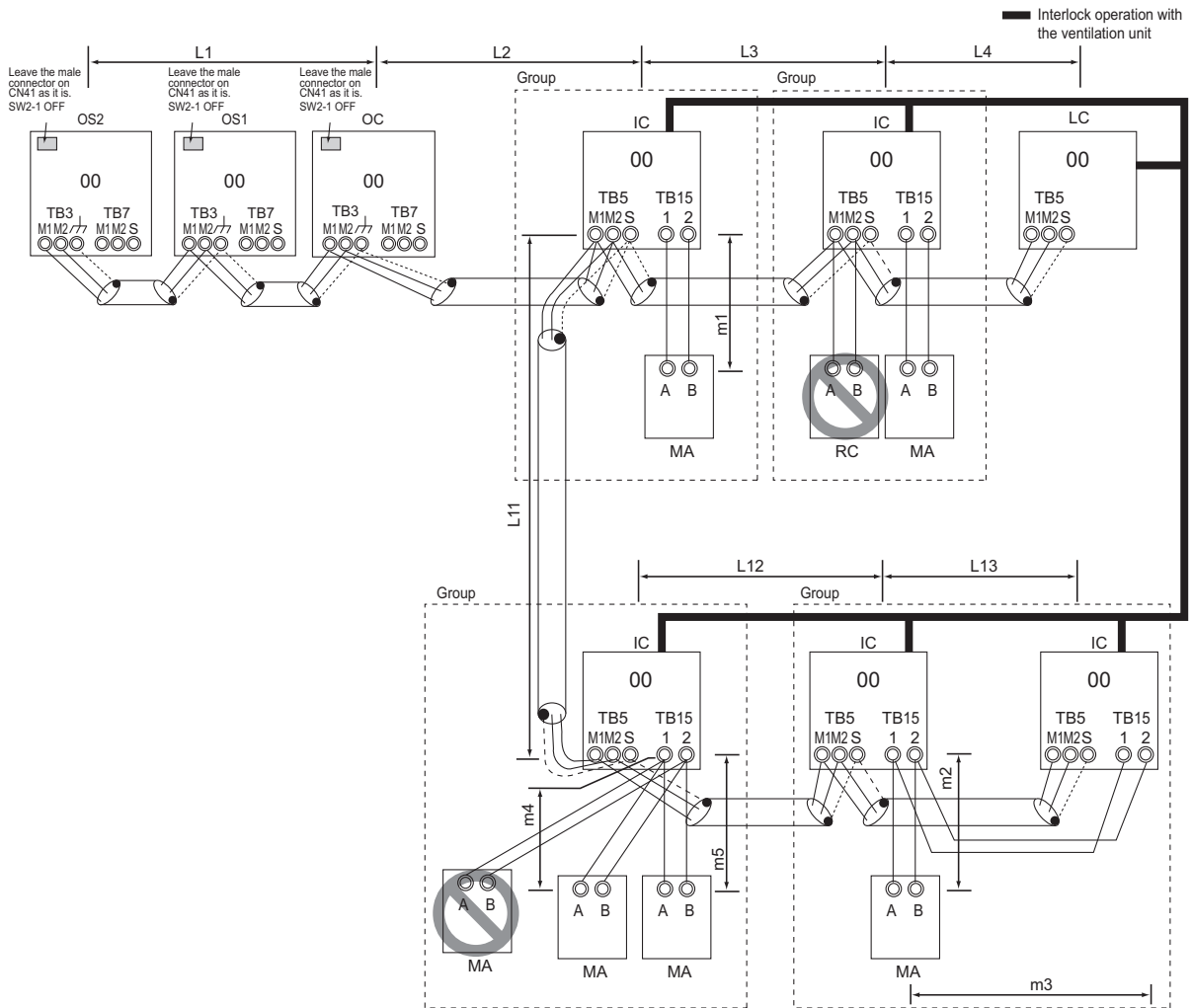

(2) Cautions

- 1) ME remote controller and MA remote controller cannot both be connected to the same group of indoor units.
- 2) No more than 2 MA remote controllers can be connected to a group of indoor units.
- 3) A transmission booster is required in a system to which more than 32 indoor units (26 units if one or more indoor units of the 200 model or above is connected) are connected.
- 4) Automatic address setup is not available if start-stop input (CN32, CN51, CN41) is used for a group operation of indoor units. Refer to "[5] 2. Manual address setup for both indoor and outdoor units".(page 30)
- 5) To connect more than 2 LOSSNAY units to indoor units in the same system, refer to the next section "[5] 2. An example of a system with one outdoor unit to which 2 or more LOSSNAY units are connected".(page 30)

(3) Maximum allowable length

- 1) Indoor/outdoor transmission line
 Maximum distance (1.25mm² [AWG16] or larger)
 $L1 + L2 + L3 + L4 \leq 200m [656ft]$
 $L1 + L2 + L11 + L12 + L13 \leq 200m [656ft]$
- 2) Transmission line for centralized control
 No connection is required.
- 3) MA remote controller wiring
 Maximum overall line length (0.3 to 1.25mm² [AWG22 to 16])
 $m1 \leq 200m [656ft]$
 $m2 + m3 \leq 200m [656ft]$
 $m4 + m5 \leq 200m [656ft]$

(4) Wiring method

1) Indoor/outdoor transmission line

Daisy-chain terminals M1 and M2 on the terminal block for indoor-outdoor transmission line (TB3) on the outdoor units (OC, OS1, OS2) (Note 1), and terminals M1 and M2 on the terminal block for indoor-outdoor transmission line (TB5) on each indoor unit (IC). (Non-polarized two-wire)

•Only use shielded cables.

Note

The outdoor units in the same refrigerant circuit are automatically designated as OC, OS1, and OS2 in the order of capacity from large to small (if two or more units have the same capacity, in the order of address from small to large).

Shielded cable connection

Daisy-chain the ground terminal ($\overline{}$) on the outdoor units (OC, OS1, OS2), and the S terminal on the terminal block (TB5) on the indoor unit (IC) with the shield wire of the shielded cable.

2) Transmission line for centralized control

No connection is required.

3) MA remote controller wiring

Connect terminals 1 and 2 on the terminal block for MA remote controller line (TB15) on the indoor unit (IC) to the terminal block on the MA remote controller (MA). (Non-polarized two-wire)

When 2 remote controllers are connected to the system

When 2 remote controllers are connected to the system, connect terminals 1 and 2 of the terminal block (TB15) on the indoor unit (IC) to the terminal block on the two MA remote controllers.

•Set one of the MA remote controllers to sub. (Refer to

(5) Address setting method

MA remote controller function selection or the installation manual for the MA remote controller for the setting method.)

Group operation of indoor units

To perform a group operation of indoor units (IC), daisy-chain terminals 1 and 2 on the terminal block (TB15) on all indoor units (IC) in the same group, and then connect terminals 1 and 2 on the terminal block (TB15) on the indoor unit on one end to the terminal block on the MA remote controller. (Non-polarized two-wire)

•When performing a group operation of indoor units that have different functions, "Automatic indoor/outdoor address setup" is not available.

4) LOSSNAY connection

Connect terminals M1 and M2 on the terminal block (TB5) on the indoor unit (IC) to the appropriate terminals on the terminal block (TB5) on LOSSNAY (LC). (Non-polarized two-wire)

•Interlock operation setting with all the indoor units in the same system will automatically be made. (It is required that the Lossnay unit be turned on before the outdoor unit.)

•Refer to "[5] 2. Manual address setup for both indoor and outdoor units" in the following cases: performing an interlock operation of part of the indoor units in the system with a LOSSNAY unit, using LOSSNAY alone without interlocking it with any units, performing an interlock operation of more than 16 indoor units with a LOSSNAY unit, or connecting two or more LOSSNAY units to indoor units in the same system.

5) Switch setting

No address settings required.

| Procedures | Unit or controller | | | Address setting range | Setting method | Notes | Factory setting |
|------------|----------------------|------------------------|------------------|-----------------------|----------------|--|-----------------|
| 1 | Indoor unit | Main unit | IC | No settings required. | - | To perform a group operation of indoor units that have different functions, refer to [5] 2.(page 30) | 00 |
| | | Sub unit | IC | | | | |
| 2 | LOSSNAY | | LC | No settings required. | - | | 00 |
| 3 | MA remote controller | Main remote controller | MA | No settings required. | - | | Main |
| | | Sub remote controller | MA | Sub remote controller | | | |
| 4 | Outdoor unit (Note) | | OC OS1 OS2 | No settings required. | - | | 00 |

Note

The outdoor units in the same refrigerant circuit are automatically designated as OC, OS1, and OS2.

2. An example of a system with one outdoor unit to which 2 or more LOSSNAY units are connected (manual address setup for both indoor and outdoor units)

(1) Sample control wiring

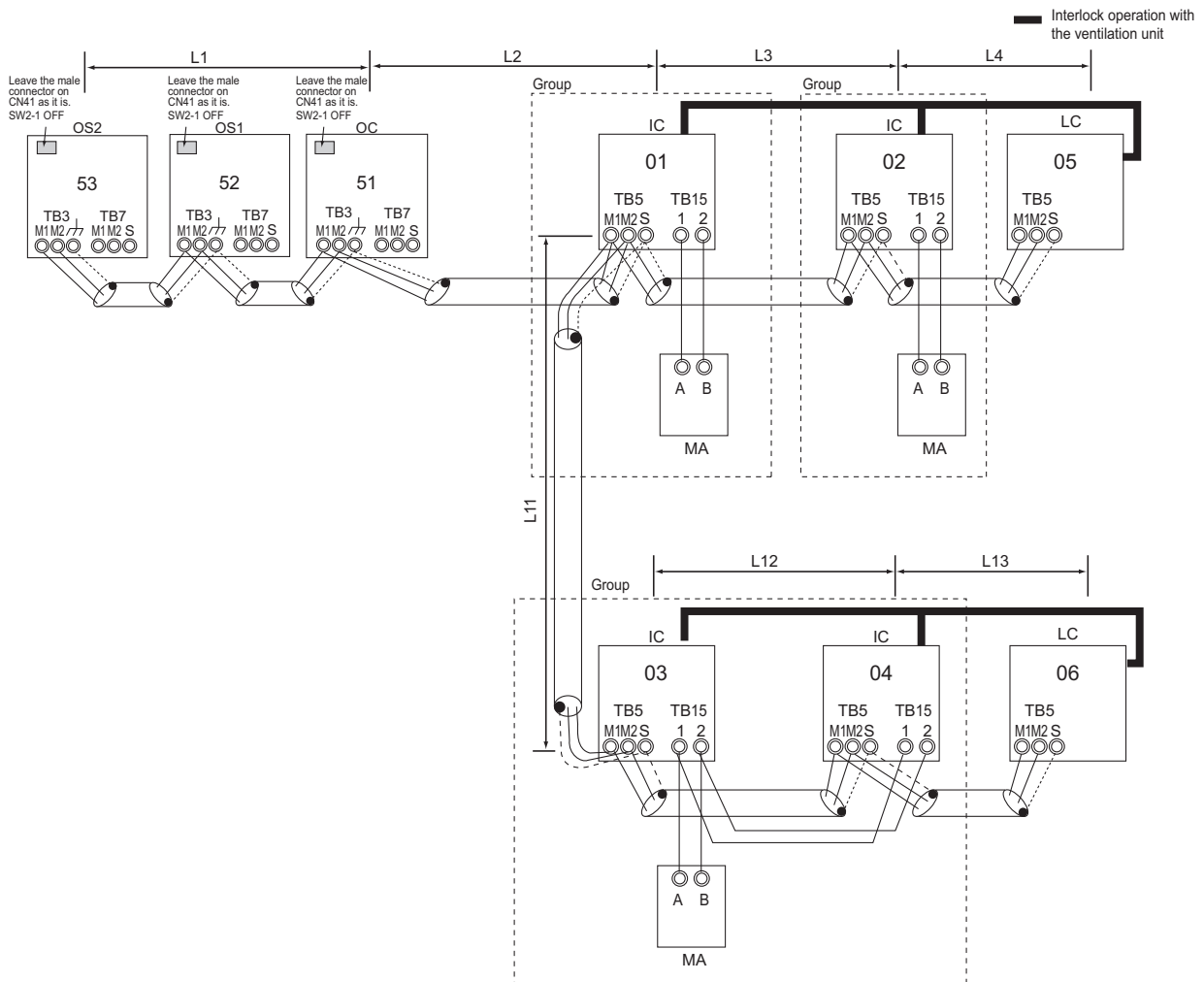

(2) Cautions

- 1) ME remote controller and MA remote controller cannot both be connected to the same group of indoor units.
- 2) No more than 2 MA remote controllers can be connected to a group of indoor units.
- 3) A transmission booster is required in a system to which more than 32 indoor units (26 units if one or more indoor units of the 200 model or above is connected) are connected.

(3) Maximum allowable length

- 1) Indoor/outdoor transmission line
Same as [5] 1.
- 2) Transmission line for centralized control
No connection is required.
- 3) MA remote controller wiring
Same as [5] 1.

(4) Wiring method

1) Indoor/outdoor transmission line

Same as [5] 1.

Shielded cable connection

Same as [5] 1.

2) Transmission line for centralized control

No connection is required.

3) MA remote controller wiring

Same as [5] 1.

When 2 remote controllers are connected to the system

Same as [5] 1.

Group operation of indoor units

Same as [5] 1.

(5) Address setting method

4) LOSSNAY connection

Connect terminals M1 and M2 on the terminal block (TB5) on the indoor unit (IC) to the appropriate terminals on the terminal block (TB5) on LOSSNAY (LC). (Non-polarized two-wire)

♦Interlock setting between the indoor units and LOSSNAY units must be entered on the remote controller. (Refer to "IV [3] Interlock Settings via the MA Remote Controller" or the installation manual for the MA remote controller for the setting method.)

5) Switch setting

Address setting is required as follows.

| Procedures | Unit or controller | | | Address setting range | Setting method | Notes | Factory setting |
|------------|----------------------|------------------------|------------------|-----------------------|---|--|-----------------|
| 1 | Indoor unit | Main unit | IC | 01 to 50 | Assign the smallest address to the main unit in the group. | To perform a group operation of indoor units that have different functions, designate the indoor unit in the group with the greatest number of functions as the main unit. | 00 |
| | | Sub unit | | | Assign sequential numbers starting with the address of the main unit in the same group +1. (Main unit address +1, main unit address +2, main unit address +3, etc.) | | |
| 2 | LOSSNAY | | LC | 01 to 50 | Assign an arbitrary but unique address to each of these units after assigning an address to all indoor units. | None of these addresses may overlap any of the indoor unit addresses. | 00 |
| 3 | MA remote controller | Main remote controller | MA | No settings required. | - | | Main |
| | | Sub remote controller | MA | Sub remote controller | Settings to be made according to the remote controller function selection | | |
| 4 | Outdoor unit | | OC OS1 OS2 | 51 to 100 | Assign sequential address to the outdoor units in the same refrigerant circuit. The outdoor units are automatically designated as OC, OS1, and OS2.(Note) | To set the address to 100, set the rotary switches to 50. | 00 |

Note

The outdoor units in the same refrigerant circuit are automatically designated as OC, OS1, and OS2.

3. Group operation of units in a system with multiple outdoor units

(1) Sample control wiring

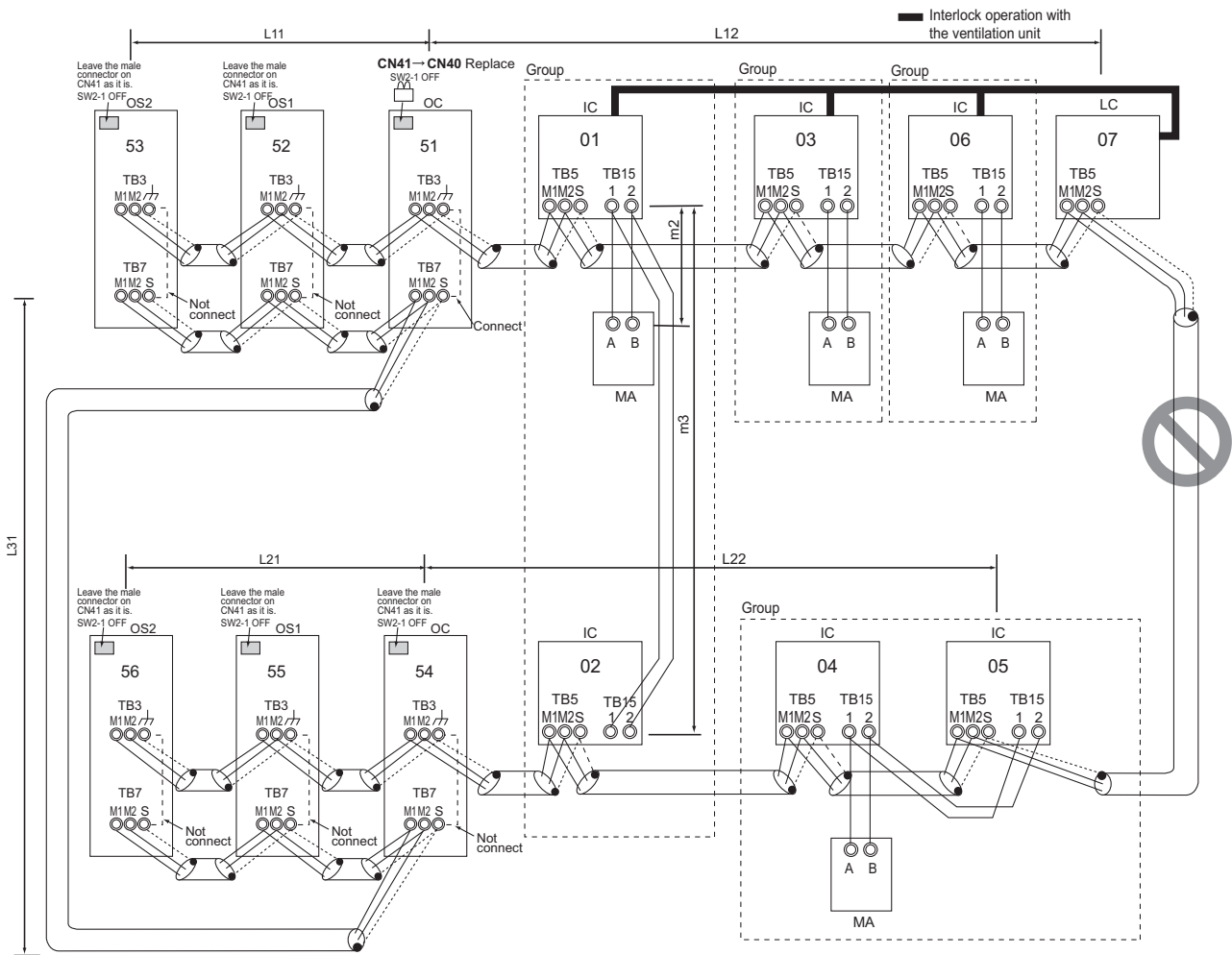

(2) Cautions

- 1) ME remote controller and MA remote controller cannot both be connected to the same group of indoor units.
- 2) No more than 2 MA remote controllers can be connected to a group of indoor units.
- 3) Do not connect the terminal blocks (TB5) on the indoor units that are connected to different outdoor units with each other.
- 4) Replacement of male power jumper connector (CN41) must be performed only on one of the outdoor units.
- 5) Provide grounding to S terminal on the terminal block for transmission line for centralized control (TB7) on only one of the outdoor units.
- 6) A transmission booster is required in a system to which more than 32 indoor units (26 units if one or more indoor units of the 200 model or above is connected) are connected.

(3) Maximum allowable length

- 1) Indoor/outdoor transmission line
 Maximum distance (1.25mm² [AWG16] or larger)
 $L11+L12 \leq 200\text{m}$ [656ft]
 $L21+L22 \leq 200\text{m}$ [656ft]
- 2) Transmission line for centralized control
 $L31+L21 \leq 200\text{m}$ [656ft]
- 3) MA remote controller wiring
 Same as [5] 1.
- 4) Maximum line distance via outdoor unit
 (1.25mm² [AWG16] or larger)
 $L12+L31+L22 \leq 500\text{m}$ [1640ft]
 $L11+L31+L21 \leq 500\text{m}$ [1640ft]

(4) Wiring method

- 1) Indoor/outdoor transmission line

Same as [5] 1.

•Only use shielded cables.

Shielded cable connection

Same as [5] 1.

- 2) Transmission line for centralized control

Daisy-chain terminals M1 and M2 on the terminal block for transmission line for centralized control (TB7) on the outdoor units (OC) in different refrigerant circuits and on the OC, OS1, and OS2 in the same refrigerant circuit
 If a power supply unit is not connected to the transmission line for centralized control, replace the power jumper connector on the control board from CN41 to CN40 on only one of the outdoor units.

Note

The outdoor units in the same refrigerant circuit are automatically designated as OC, OS1, and OS2 in the order of capacity from large to small (if two or more units have the same capacity, in the order of address from small to large).

•Only use shielded cables.

Shielded cable connection

Daisy-chain the S terminal on the terminal block (TB7) on the outdoor units (OC, OS1, OS2) with the shield wire of the shielded cable. Short-circuit the earth terminal (r) and the S terminal on the terminal block (TB7) on the outdoor unit whose power jumper connector is mated with CN40.

- 3) MA remote controller wiring

Same as [5] 1.

When 2 remote controllers are connected to the system

Same as [5] 1.

Group operation of indoor units

Same as [5] 2.

- 4) LOSSNAY connection

Same as [5] 2.

- 5) Switch setting

Address setting is required as follows.

(5) Address setting method

| Procedures | Unit or controller | | | Address setting range | Setting method | Notes | Factory setting |
|------------|----------------------|------------------------|------------------|-----------------------|---|--|-----------------|
| 1 | Indoor unit | Main unit | IC | 01 to 50 | Assign the smallest address to the main unit in the group. | To perform a group operation of indoor units that have different functions, designate the indoor unit in the group with the greatest number of functions as the main unit. | 00 |
| | | Sub unit | | | Assign sequential numbers starting with the address of the main unit in the same group +1. (Main unit address +1, main unit address +2, main unit address +3, etc.) | | |
| 2 | LOSSNAY | | LC | 01 to 50 | Assign an arbitrary but unique address to each of these units after assigning an address to all indoor units. | None of these addresses may overlap any of the indoor unit addresses. | 00 |
| 3 | MA remote controller | Main remote controller | MA | No settings required. | - | | Main |
| | | Sub remote controller | MA | Sub remote controller | Settings to be made according to the remote controller function selection | | |
| 4 | Outdoor unit | | OC OS1 OS2 | 51 to 100 | Assign sequential address to the outdoor units in the same refrigerant circuit. The outdoor units are automatically designated as OC, OS1, and OS2. (Note) | To set the address to 100, set the rotary switches to 50. | 00 |

Note

The outdoor units in the same refrigerant circuit are automatically designated as OC, OS1, and OS2.

4. A system in which a system controller is connected to the transmission line for centralized control and which is powered from an outdoor unit

(1) Sample control wiring

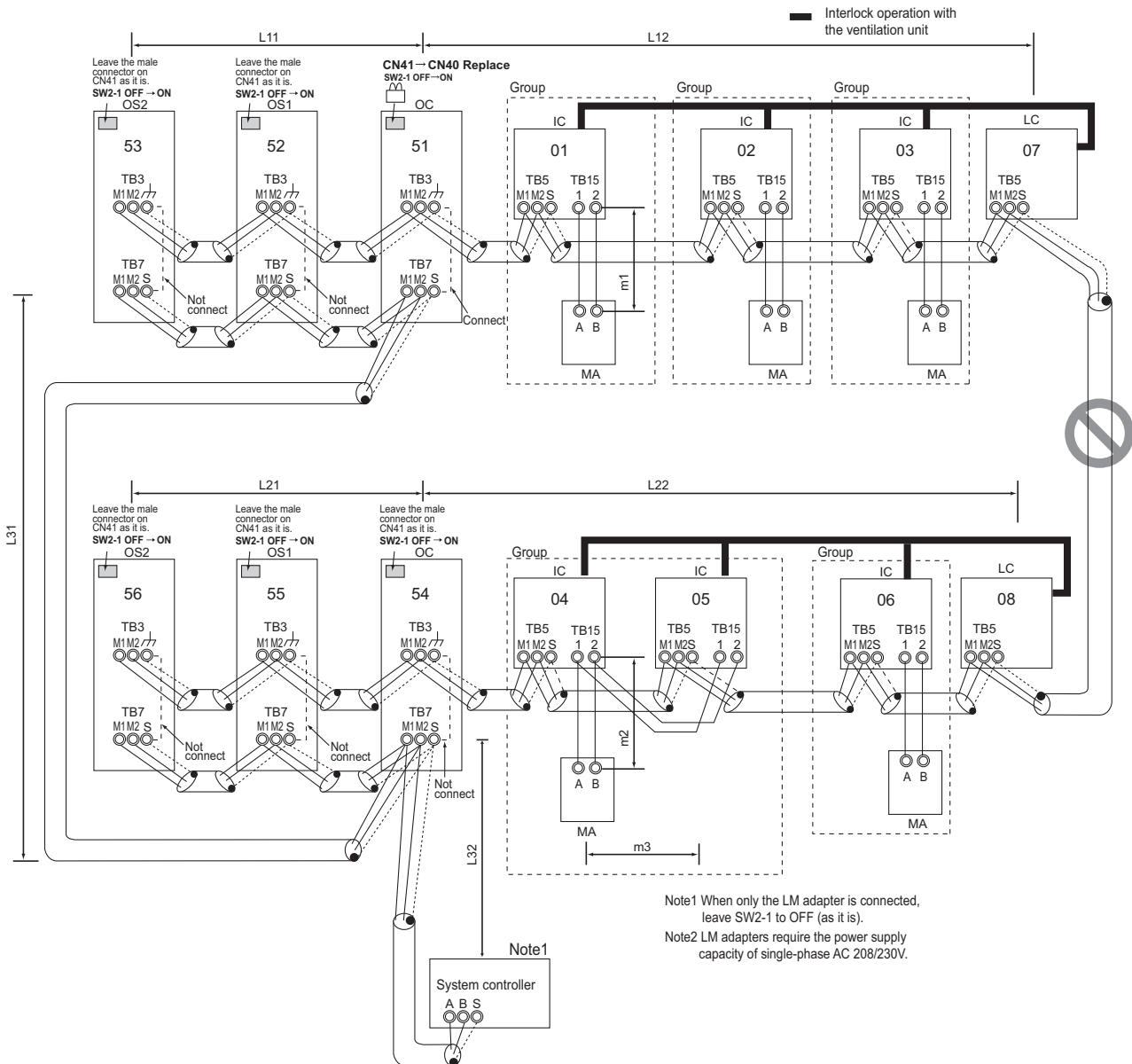

(2) Cautions

- 1) ME remote controller and MA remote controller cannot both be connected to the same group of indoor units.
- 2) No more than 2 MA remote controllers can be connected to a group of indoor units.
- 3) Do not connect the terminal blocks (TB5) on the indoor units that are connected to different outdoor units with each other.
- 4) Replacement of male power jumper connector (CN41) must be performed only on one of the outdoor units.
- 5) Short-circuit the shield terminal (S terminal) and the earth terminal () on the terminal block for transmission line for centralized control (TB7) on the outdoor unit whose power jumper connector is mated with CN40.
- 6) A transmission booster is required in a system to which more than 32 indoor units (26 units if one or more indoor units of the 200 model or above is connected) are connected.
- 7) When a power supply unit is connected to the transmission line for centralized control, leave the power jumper connector on CN41 as it is (factory setting).

(3) Maximum allowable length

- 1) Indoor/outdoor transmission line
Same as [5] 3.
- 2) Transmission line for centralized control
 $L_{31} + L_{32}(L_{21}) \leq 200\text{m}$ [656ft]
- 3) MA remote controller wiring
Same as [5] 1.
- 4) Maximum line distance via outdoor unit
(1.25mm² [AWG16] or larger)
 $L_{32} + L_{31} + L_{12}(L_{11}) \leq 500\text{m}$ [1640ft]
 $L_{32} + L_{22}(L_{21}) \leq 500\text{m}$ [1640ft]
 $L_{12}(L_{11}) + L_{31} + L_{22}(L_{21}) \leq 500\text{m}$ [1640ft]

(4) Wiring method

- 1) Indoor/outdoor transmission line

Same as [5] 1.
Only use shielded cables.

Shielded cable connection

Same as [5] 1.

- 2) Transmission line for centralized control

Daisy-chain terminals A and B on the system controller, terminals M1 and M2 on the terminal block for transmission line for centralized control (TB7) on the outdoor units (OC) in different refrigerant circuits and on the outdoor units (OC, OS1, and OS2) in the same refrigerant circuit.

If a power supply unit is not connected to the transmission line for centralized control, replace the power jumper connector on the control board from CN41 to CN40 on only one of the outdoor units.

If a system controller is connected, set the central control switch (SW2-1) on the control board of all outdoor units to "ON."

Note

The outdoor units in the same refrigerant circuit are automatically designated as OC, OS1, and OS2 in the order of capacity from large to small (if two or more units have the same capacity, in the order of address from small to large).

•Only use shielded cables.

(5) Address setting method

Shielded cable connection

Daisy-chain the S terminal on the terminal block (TB7) on the outdoor units (OC, OS1, OS2) with the shield wire of the shielded cable. Short-circuit the earth terminal (E) and the S terminal on the terminal block (TB7) on the outdoor unit whose power jumper connector is mated with CN40.

- 3) MA remote controller wiring

Same as [5] 1.

When 2 remote controllers are connected to the system

Same as [5] 1.

Group operation of indoor units

Same as [5] 1.

- 4) LOSSNAY connection

Connect terminals M1 and M2 on the terminal block (TB5) on the indoor unit (IC) to the appropriate terminals on the terminal block for indoor-outdoor transmission line (TB5) on LOSSNAY (LC). (Non-polarized 2-core cable)

•Indoor units must be interlocked with the LOSSNAY unit using the system controller. (Refer to the operation manual for the system controller for the setting method.) Interlock setting from the remote controller is required if the ON/OFF remote controller alone or the LM adapter alone is connected.

- 5) Switch setting

Address setting is required as follows.

| Procedures | Unit or controller | | | Address setting range | Setting method | Notes | Factory setting |
|------------|----------------------|------------------------|------------------|-----------------------|---|--|-----------------|
| 1 | Indoor unit | Main unit | IC | 01 to 50 | Assign the smallest address to the main unit in the group. | To perform a group operation of indoor units that have different functions, designate the indoor unit in the group with the greatest number of functions as the main unit. | 00 |
| | | Sub unit | | | Assign sequential numbers starting with the address of the main unit in the same group +1. (Main unit address +1, main unit address +2, main unit address +3, etc.) | | |
| 2 | LOSSNAY | | LC | 01 to 50 | Assign an arbitrary but unique address to each of these units after assigning an address to all indoor units. | None of these addresses may overlap any of the indoor unit addresses. | 00 |
| 3 | MA remote controller | Main remote controller | MA | No settings required. | - | Enter the same indoor unit group settings on the system controller as the ones that were entered on the MA remote controller. | Main |
| | | Sub remote controller | MA | Sub remote controller | Settings to be made according to the remote controller function selection | | |
| 4 | Outdoor unit | | OC OS1 OS2 | 51 to 100 | Assign sequential address to the outdoor units in the same refrigerant circuit. The outdoor units are automatically designated as OC, OS1, and OS2.(Note) | To set the address to 100, set the rotary switches to 50. | 00 |

Note

The outdoor units in the same refrigerant circuit are automatically designated as OC, OS1, and OS2.

5. An example of a system in which a system controller is connected to the indoor-outdoor transmission line (except LM adapter)

(1) Sample control wiring

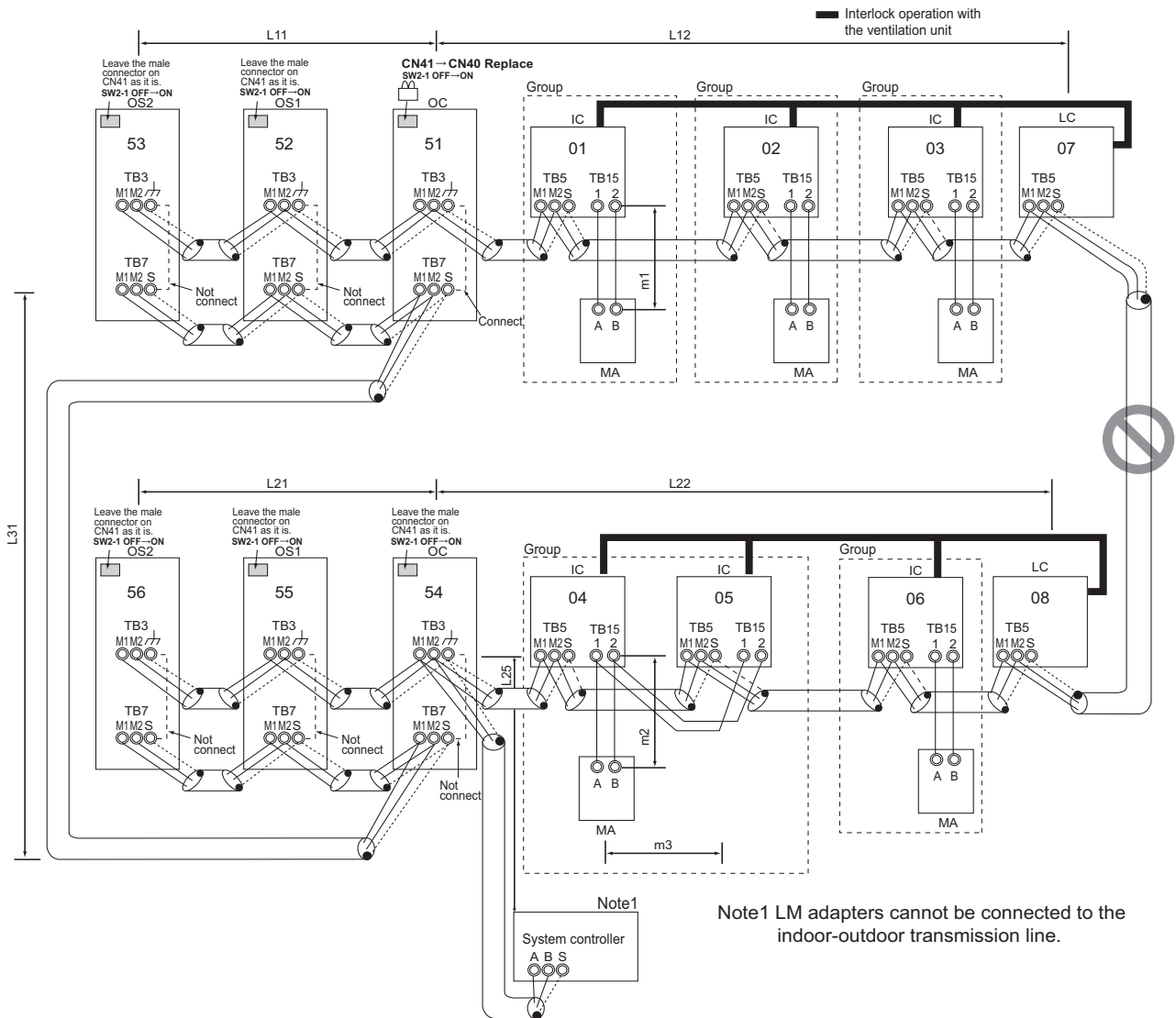

(2) Cautions

- 1) ME remote controller and MA remote controller cannot both be connected to the same group of indoor units.
- 2) No more than 2 MA remote controllers can be connected to a group of indoor units.
- 3) Do not connect the terminal blocks (TB5) on the indoor units that are connected to different outdoor units with each other.
- 4) Replacement of male power jumper connector (CN41) must be performed only on one of the outdoor units.
- 5) Provide grounding to S terminal on the terminal block for transmission line for centralized control (TB7) on only one of the outdoor units.
- 6) A maximum of 3 system controllers can be connected to the indoor-outdoor transmission line, with the exception that only one G(B)-50A may be connected.
- 7) When the total number of indoor units exceeds 26, it may not be possible to connect a system controller on the indoor-outdoor transmission line.
- 8) In a system to which more than 18 indoor units including one or more indoor units of 200 model or above are connected, there may be cases in which the system controller cannot be connected to the indoor-outdoor transmission line.

(3) Maximum allowable length

- 1) Indoor/outdoor transmission line
 Maximum distance (1.25mm² [AWG16] or larger)
 $L11+L12 \leq 200m$ [656ft]
 $L21+L22 \leq 200m$ [656ft]
 $L25 \leq 200m$ [656ft]
- 2) Transmission line for centralized control
 $L31+L21 \leq 200m$ [656ft]
- 3) MA remote controller wiring
 Same as [5] 1.
- 4) Maximum line distance via outdoor unit (1.25mm² [AWG16] or larger)
 $L25+L31+L12(L11) \leq 500m$ [1640ft]
 $L12(L11)+L31+L22(L21) \leq 500m$ [1640ft]
 $L25+L22(L21) \leq 500m$ [1640ft]

(4) Wiring method

1) Indoor/outdoor transmission line

Daisy-chain terminals M1 and M2 on the terminal block for indoor-outdoor transmission line (TB3) on the outdoor units (OC, OS1, OS2) (Note 1), terminals M1 and M2 on the terminal block for indoor-outdoor transmission line (TB5) on each indoor unit (IC), and the S terminal on the system controller. (Non-polarized two-wire)

- Only use shielded cables.

Note

The outdoor units in the same refrigerant circuit are automatically designated as OC, OS1, and OS2 in the order of capacity from large to small (if two or more units have the same capacity, in the order of address from small to large).

Shielded cable connection

Daisy-chain the ground terminal (⏏) on the outdoor units (OC, OS1, OS2), the S terminal on the terminal block (TB5) on the indoor unit (IC), and the S terminal on the system controller with the shield wire of the shielded cable.

2) Transmission line for centralized control

Daisy-chain terminals M1 and M2 on the terminal block for transmission line for centralized control (TB7) on the outdoor units (OC) in different refrigerant circuits and on the OC, OS1, and OS2 in the same refrigerant circuit. If a power supply unit is not connected to the transmission line for centralized control, replace the power jumper connector on the control board from CN41 to CN40 on only one of the outdoor units.

(5) Address setting method

Set the central control switch (SW2-1) on the control board of all outdoor units to "ON."

- Only use shielded cables.

Shielded cable connection

Daisy-chain the S terminal on the terminal block (TB7) on the outdoor units (OC, OS1, OS2) with the shield wire of the shielded cable. Short-circuit the earth terminal (⏏) and the S terminal on the terminal block (TB7) on the outdoor unit whose power jumper connector is mated with CN40.

3) MA remote controller wiring

Same as [5] 1.

When 2 remote controllers are connected to the system

Same as [5] 1.

Group operation of indoor units

Same as [5] 1.

4) LOSSNAY connection

Connect terminals M1 and M2 on the terminal block (TB5) on the indoor units (IC) to the appropriate terminals on the terminal block for indoor-outdoor transmission line (TB5) on LOSSNAY (LC). (Non-polarized two-wire)

- Indoor units must be interlocked with the LOSSNAY unit using the system controller. (Refer to the operation manual for the system controller for the setting method.) Interlock setting from the remote controller is required if the ON/OFF remote controller alone is connected.

5) Switch setting

Address setting is required as follows.

| Procedures | Unit or controller | | Address setting range | Setting method | Notes | Factory setting | |
|------------|----------------------|------------------------|-----------------------|-----------------------|---|--|------|
| 1 | Indoor unit | Main unit | IC | 01 to 50 | Assign the smallest address to the main unit in the group. Assign sequential numbers starting with the address of the main unit in the same group +1. (Main unit address +1, main unit address +2, main unit address +3, etc.) | To perform a group operation of indoor units that have different functions, designate the indoor unit in the group with the greatest number of functions as the main unit. | |
| | | Sub unit | | | | | |
| 2 | LOSSNAY | | LC | 01 to 50 | Assign an arbitrary but unique address to each of these units after assigning an address to all indoor units. | None of these addresses may overlap any of the indoor unit addresses. | 00 |
| 3 | MA remote controller | Main remote controller | MA | No settings required. | - | Enter the same indoor unit group settings on the system controller as the ones that were entered on the MA remote controller. | Main |
| | | Sub remote controller | MA | Sub remote controller | Settings to be made according to the remote controller function selection | | |
| 4 | Outdoor unit | | OC OS1 OS2 | 51 to 100 | Assign sequential address to the outdoor units in the same refrigerant circuit. The outdoor units are automatically designated as OC, OS1, and OS2. (Note) | To set the address to 100, set the rotary switches to 50. | 00 |

Note

The outdoor units in the same refrigerant circuit are automatically designated as OC, OS1, and OS2.

[6] An Example of a System to which an ME Remote Controller is connected

(1) Sample control wiring

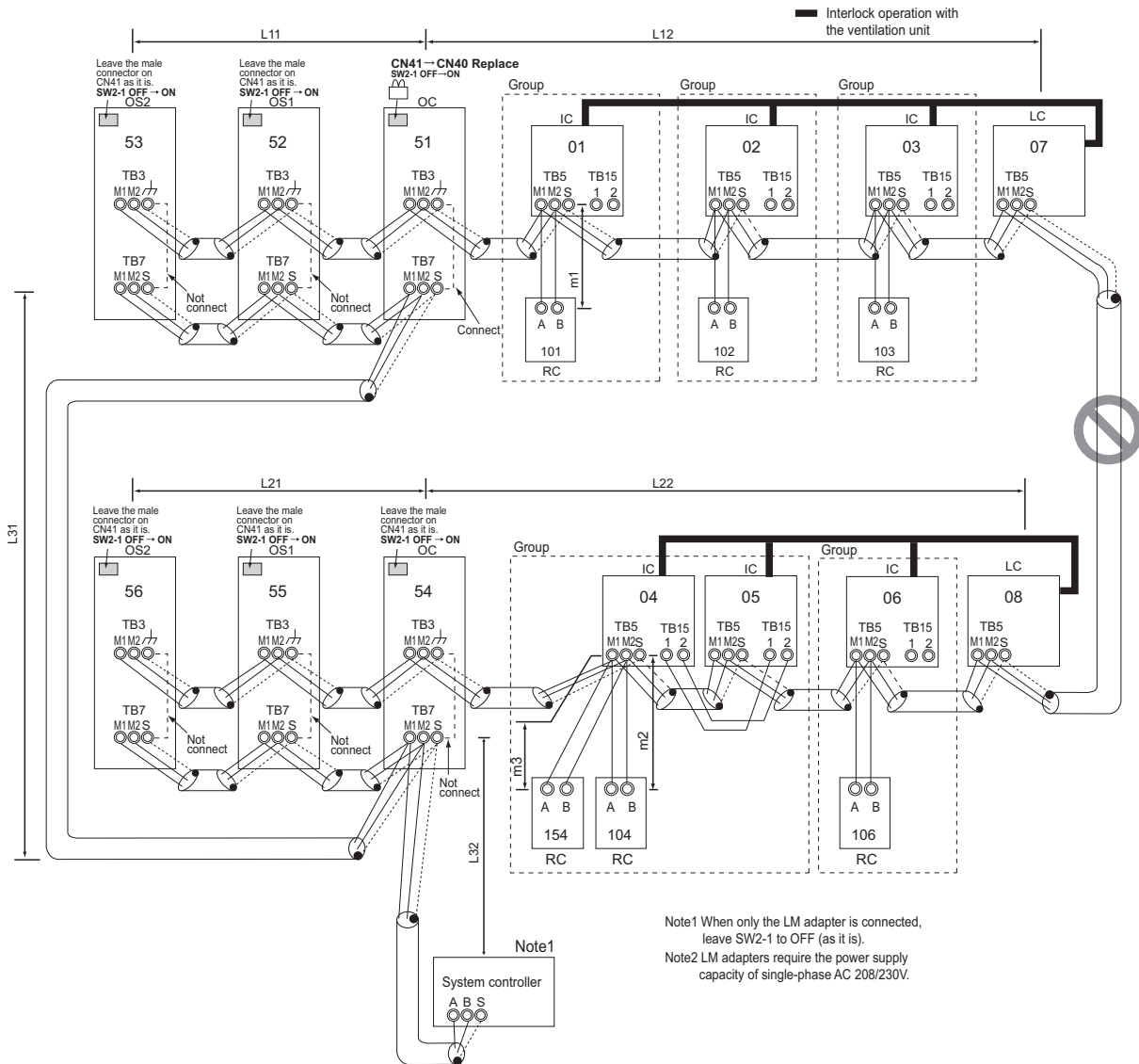

(2) Cautions

- 1) ME remote controller and MA remote controller cannot both be connected to the same group of indoor units.
- 2) No more than 3 ME remote controllers can be connected to a group of indoor units.
- 3) Do not connect the terminal blocks (TB5) on the indoor units that are connected to different outdoor units with each other.
- 4) Replace the power jumper connector of the control board from CN41 to CN40 on only one of the outdoor units.
- 5) Provide an electrical path to ground for the S terminal on the terminal block for centralized control on only one of the outdoor units.
- 6) A transmission booster must be connected to a system in which the total number of connected indoor units exceeds 20.
- 7) A transmission booster is required in a system to which more than 16 indoor including one or more indoor units of the 200 model or above are connected.
- 8) When a power supply unit is connected to the transmission line for centralized control, leave the power jumper connector on CN41 as it is (factory setting).

(3) Maximum allowable length

- 1) Indoor/outdoor transmission line
Same as [5] 3.
- 2) Transmission line for centralized control
Same as [5] 4.
- 3) ME remote controller wiring
Maximum overall line length
(0.3 to 1.25mm² [AWG22 to 16])
m1 ≤ 10m [32ft]
m2+m3 ≤ 10m [32ft]
If the standard-supplied cable must be extended, use a cable with a diameter of 1.25mm² [AWG16]. The section of the cable that exceeds 10m [32ft] must be included in the maximum indoor-outdoor transmission line distance described in (1).
When connected to the terminal block on the Simple remote controller, use cables that meet the following cable size specifications: 0.75 - 1.25 mm² [AWG18-14].
- 4) Maximum line distance via outdoor unit
(1.25mm² or larger)
Same as [5] 4.

(4) Wiring method

- 1) Indoor/outdoor transmission line
Same as [5] 1.
Shielded cable connection
Same as [5] 1.
- 2) Transmission line for centralized control
Same as [5] 4.
Shielded cable connection
Same as [5] 4.
- 3) ME remote controller wiring
ME remote controller is connectable anywhere on the indoor-outdoor transmission line.

When 2 remote controllers are connected to the system

Refer to the section on Switch Setting.
Performing a group operation (including the group operation of units in different refrigerant circuits).

- 4) LOSSNAY connection
Same as [5] 4.
- 5) Switch setting
Address setting is required as follows.

(5) Address setting method

| Procedures | Unit or controller | | | Address setting range | Setting method | Notes | Factory setting |
|------------|----------------------|------------------------|------------------|-----------------------|---|--|-----------------|
| 1 | Indoor unit | Main unit | IC | 01 to 50 | Assign the smallest address to the main unit in the group. | To perform a group operation of indoor units that have different functions, designate the indoor unit in the group with the greatest number of functions as the main unit. | 00 |
| | | Sub unit | | | Assign sequential numbers starting with the address of the main unit in the same group +1. (Main unit address +1, main unit address +2, main unit address +3, etc.) | | |
| 2 | LOSSNAY | | LC | 01 to 50 | Assign an arbitrary but unique address to each of these units after assigning an address to all indoor units. | None of these addresses may overlap any of the indoor unit addresses. | 00 |
| 3 | ME remote controller | Main remote controller | RC | 101 to 150 | Add 100 to the main unit address in the group | <ul style="list-style-type: none"> ♦It is not necessary to set the 100s digit. ♦To set the address to 200, set the rotary switches to 00. | 101 |
| | | Sub remote controller | RC | 151 to 200 | Add 150 to the main unit address in the group | | |
| 4 | Outdoor unit | | OC OS1 OS2 | 51 to 100 | Assign sequential address to the outdoor units in the same refrigerant circuit. The outdoor units are automatically designated as OC, OS1, and OS2. (Note) | To set the address to 100, set the rotary switches to 50. | 00 |

Note

The outdoor units in the same refrigerant circuit are automatically designated as OC, OS1, and OS2.

[7] An Example of a System to which both MA Remote Controller and ME Remote Controller are connected

(1) Sample control wiring

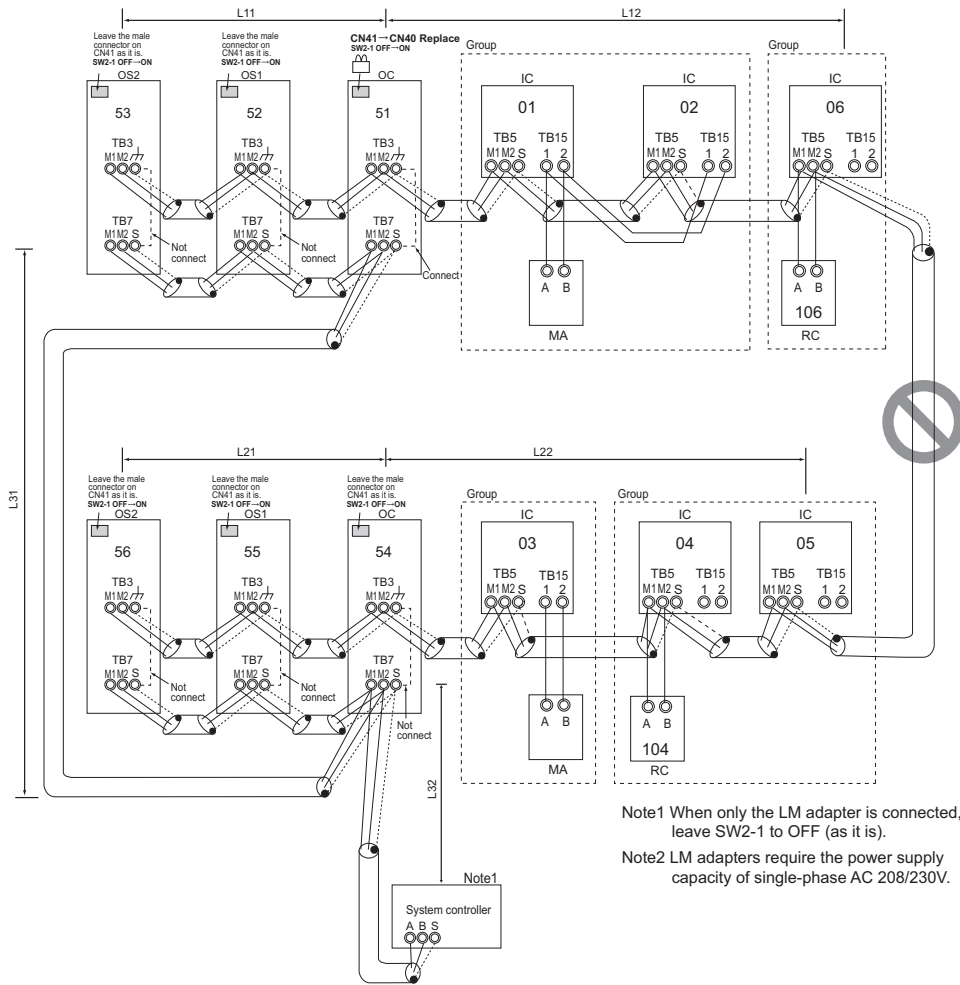

(2) Cautions

- 1) Be sure to connect a system controller.
- 2) ME remote controller and MA remote controller cannot both be connected to the same group of indoor units.
- 3) Assign to the indoor units connected to the MA remote controller addresses that are smaller than those of the indoor units that are connected to the ME remote controller.
- 4) No more than 2 ME remote controllers can be connected to a group of indoor units.
- 5) No more than 2 MA remote controllers can be connected to a group of indoor units.
- 6) Do not connect the terminal blocks (TB5) on the indoor units that are connected to different outdoor units with each other.
- 7) Replace the power jumper connector of the control board from CN41 to CN40 on only one of the outdoor units.
- 8) Provide an electrical path to ground for the S terminal on the terminal block for centralized control on only one of the outdoor units.
- 9) A transmission booster must be connected to a system in which the total number of connected indoor units exceeds 20.
- 10) A transmission booster is required in a system to which more than 16 indoor including one or more indoor units of the 200 model or above are connected.
- 11) When a power supply unit is connected to the transmission line for centralized control, leave the power jumper connector on CN41 as it is (factory setting).

(3) Maximum allowable length

- 1) Indoor/outdoor transmission line
Same as [5] 3.
- 2) Transmission line for centralized control
Same as [5] 4.
- 3) MA remote controller wiring
Same as [5] 1.
- 4) ME remote controller wiring
Same as [5] 1.
- 5) Maximum line distance via outdoor unit (1.25mm² or larger)
Same as [5] 4.

(4) Wiring method

- 1) Indoor/outdoor transmission line
Same as [5] 1.
Shielded cable connection
Same as [5] 1.
- 2) Transmission line for centralized control
Same as [5] 4.
Shielded cable connection
Same as [5] 4.
- 3) MA remote controller wiring
Same as [5] 1.
When 2 remote controllers are connected to the system

- Same as [5] 1.
Group operation of indoor units
Same as [5] 1.
- 4) ME remote controller wiring
Same as [6]
When 2 remote controllers are connected to the system
Same as [6]
Group operation of indoor units
Same as [6]
 - 5) LOSSNAY connection
Same as [5] 4.
 - 6) Switch setting
Address setting is required as follows.

(5) Address setting method

| Procedures | Unit or controller | | | | Address setting range | Setting method | Notes | Factory setting |
|------------|---|------------------------|-----------------------|-----------------------|--|---|---|-----------------|
| 1 | Operation with the MA remote controller | Indoor unit | Main unit | IC | 01 to 50 | Assign the smallest address to the main unit in the group. | <ul style="list-style-type: none"> •Assign an address smaller than that of the indoor unit that is connected to the ME remote controller. •Enter the same indoor unit group settings on the system controller as the ones that were entered on the MA remote controller. •To perform a group operation of indoor units that have different functions, designate the indoor unit in the group with the greatest number of functions as the main unit. | 00 |
| | | | Sub unit | | | Assign sequential numbers starting with the address of the main unit in the same group +1. (Main unit address +1, main unit address +2, main unit address +3, etc.) | | |
| | MA remote controller | Main remote controller | MA | No settings required. | - | Settings to be made according to the remote controller function selection | | Main |
| | Sub remote controller | MA | Sub remote controller | | | | | |
| 2 | Operation with the ME remote controller | Indoor unit | Main unit | IC | 01 to 50 | Assign the smallest address to the main unit in the group. | <ul style="list-style-type: none"> •Enter the indoor unit group settings on the system controller (MELANS). •Assign an address larger than those of the indoor units that are connected to the MA remote controller. •To perform a group operation of indoor units that have different functions, designate the indoor unit in the group with the greatest number of functions as the main unit. | 00 |
| | | | Sub unit | | | Assign sequential numbers starting with the address of the main unit in the same group +1. (Main unit address +1, main unit address +2, main unit address +3, etc.) | | |
| | ME remote controller | Main remote controller | RC | 101 to 150 | Add 100 to the main unit address in the group. | <ul style="list-style-type: none"> •It is not necessary to set the 100s digit. •To set the address to 200, set the rotary switches to 00. | | 101 |
| | | Sub remote controller | RC | 151 to 200 | Add 150 to the main unit address in the group. | | | |
| 3 | LOSSNAY | | | LC | 01 to 50 | Assign an arbitrary but unique address to each of these units after assigning an address to all indoor units. | None of these addresses may overlap any of the indoor unit addresses. | 00 |
| 4 | Outdoor unit | | | OC OS1 OS2 | 51 to 100 | Assign sequential address to the outdoor units in the same refrigerant circuit. The outdoor units are automatically designated as OC, OS1, and OS2. (Note) | To set the address to 100, set the rotary switches to 50. | 00 |

Note

The outdoor units in the same refrigerant circuit are automatically designated as OC, OS1, and OS2.

[8] Restrictions on Pipe Length

(1) End branching

P200 - P450 models

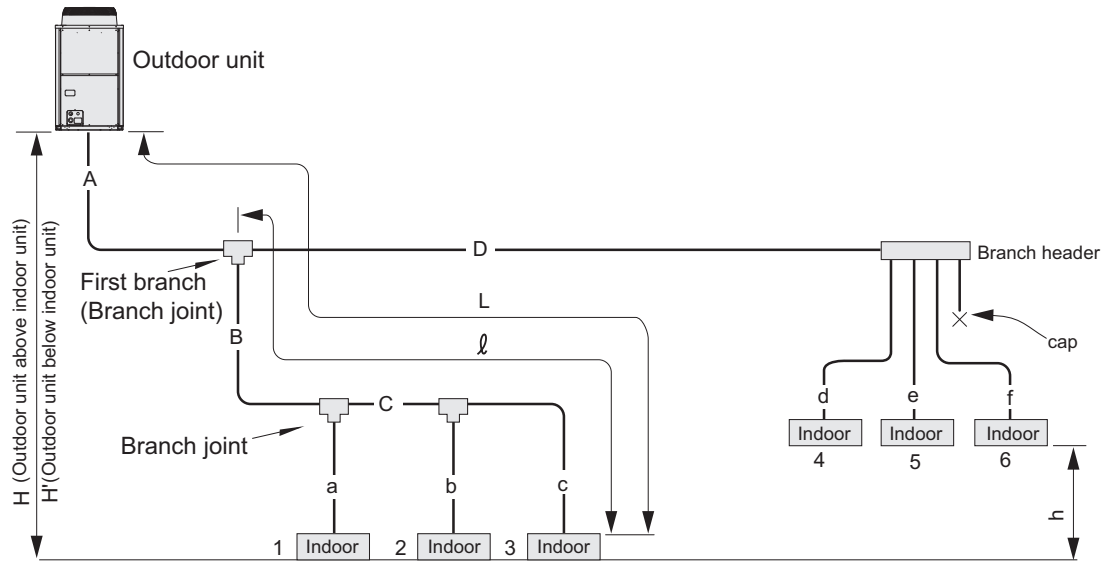

Unit: m [ft]

| Operation | | Pipe sections | Allowable length of pipes |
|-------------------|--|--------------------------------|--|
| Length | Total pipe length | $A+B+C+D+a+b+c+d+e+f$ | 1000 [3280] or less |
| | Total pipe length (L) from the outdoor unit to the farthest indoor unit | $A+B+C+c$ or $A+D+f$ | 165 [541] or less (Equivalent length 190 [623] or less) |
| | Total pipe length from the first branch to the farthest indoor unit (ℓ) | $B+C+c$ or $D+f$ | 40 [131] or less |
| Height difference | Between indoor and outdoor units | Outdoor unit above indoor unit | 50 [164] or less |
| | | Outdoor unit below indoor unit | 40 [131] or less ^{*1} |
| | Between indoor units | h | 15 [49] or less |

*1. 4 m [13 ft] or less if cooling operation is performed with the outside air temperature of 10°C or below.

P500 - P1250 models

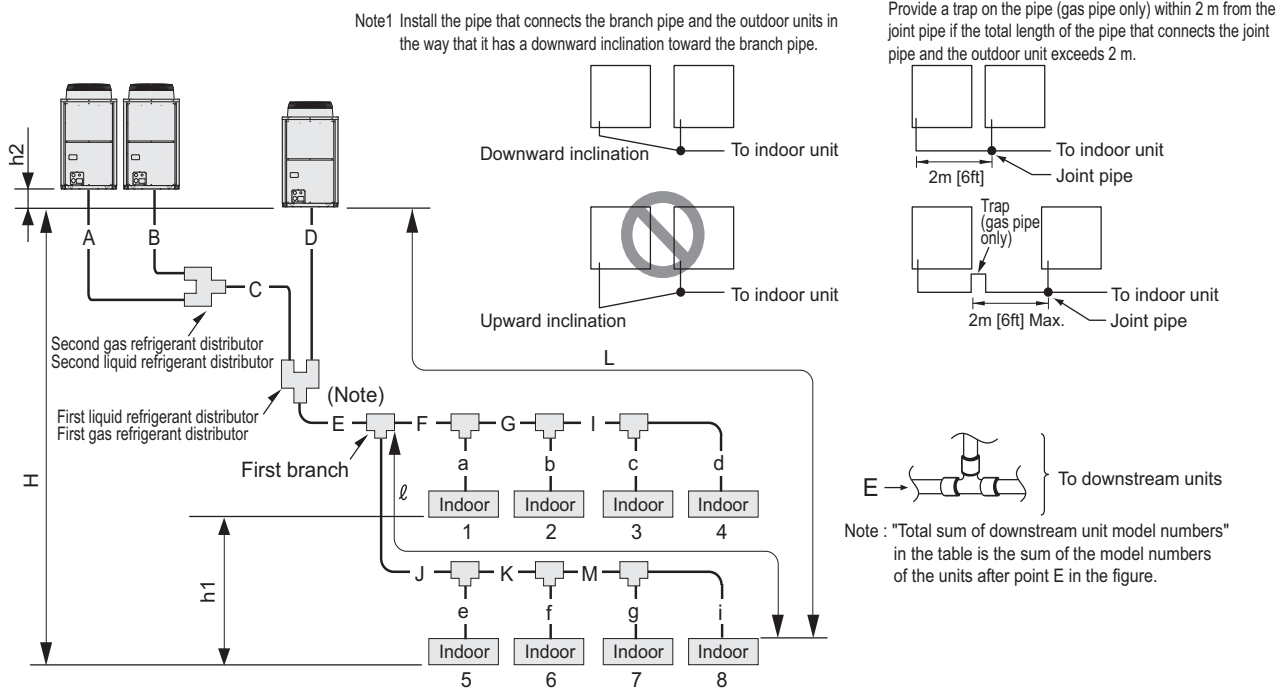

Unit: m [ft]

| Operation | | Pipe sections | Allowable length of pipes |
|-------------------|---|---------------------------------------|---|
| Length | Between outdoor units | A+B+C+D | 10 [32] or less |
| | Total pipe length | A+B+C+D+E+F+G+I+J+K+M+a+b+c+d+e+f+g+i | 1000 [3280] or less |
| | Total pipe length (L) from the outdoor unit to the farthest indoor unit | A(B)+C+E+J+K+M+i | 165 [541] or less (Equivalent length 190 [623] or less) |
| | Total pipe length from the first branch to the farthest indoor unit (ℓ) | G+I+J+i | 40 [131] or less |
| Height difference | Between indoor and outdoor units | H | 50 [164] or less (40 [131] or below if outdoor unit is below indoor unit) *1 |
| | Between indoor units | h1 | 15 [49] or less |
| | Between outdoor units | h2 | 0.1[0.3] or less |

*1. 4 m [13 ft] or less if cooling operation is performed with the outside air temperature of 10°C or below.

1. Refrigerant pipe size**(1) Diameter of the refrigerant pipe between the outdoor unit and the first branch (outdoor unit pipe size)**

| Outdoor unit set name (total capacity) | Liquid pipe size (mm) [inch] | Gas pipe size (mm) [inch] |
|---|------------------------------|---------------------------|
| 200 model | ø9.52 [3/8"] | ø19.05 [3/4"] |
| 250 model | ø9.52 [3/8"] ^{*1} | ø22.2 [7/8"] |
| 300 model | ø9.52 [3/8"] ^{*2} | ø22.2 [7/8"] |
| 350 model | ø12.7 [1/2"] | ø28.58 [1-1/8"] |
| 400 model | ø12.7 [1/2"] | ø28.58 [1-1/8"] |
| 450 model | ø15.88 [5/8"] | ø28.58 [1-1/8"] |
| 500 model | ø15.88 [5/8"] | ø28.58 [1-1/8"] |
| 550 model | ø15.88 [5/8"] | ø28.58 [1-1/8"] |
| 600 model | ø15.88 [5/8"] | ø28.58 [1-1/8"] |
| 650 model | ø15.88 [5/8"] | ø28.58 [1-1/8"] |
| 700 - 800 model | ø19.05 [3/4"] | ø34.93 [1-3/8"] |
| 850 - 1250 model | ø19.05 [3/4"] | ø41.28 [1-5/8"] |

*1. Use ø12.7 [1/2"] pipes if the piping length exceeds 90 m [295 ft].

*2. Use ø12.7 [1/2"] pipes if the piping length exceeds 40 m [131 ft].

(2) Size of the refrigerant pipe between the first branch and the indoor unit (indoor unit pipe size)

| model | Pipe diameter (mm) [inch] | |
|-----------------|---------------------------|-----------------|
| 20 - 50 models | Liquid pipe | ø6.35 [1/4"] |
| | Gas pipe | ø12.7 [1/2"] |
| 63 - 140 models | Liquid pipe | ø9.52 [3/8"] |
| | Gas pipe | ø15.88 [5/8"] |
| 200 model | Liquid pipe | ø9.52 [3/8"] |
| | Gas pipe | ø19.05 [3/4"] |
| 250 model | Liquid pipe | ø9.52 [3/8"] |
| | Gas pipe | ø22.2 [7/8"] |
| 400 model | Liquid pipe | ø12.7 [1/2"] |
| | Gas pipe | ø28.58 [1-1/8"] |
| 500 model | Liquid pipe | ø15.88 [5/8"] |
| | Gas pipe | ø28.58 [1-1/8"] |

(3) Size of the refrigerant pipe between the branches for connection to indoor units

| Total capacity of the downstream units | Liquid pipe size (mm) [inch] | Gas pipe size (mm) [inch] |
|---|------------------------------|---------------------------|
| - 140 | ø9.52 [3/8"] | ø15.88 [5/8"] |
| P141 - P200 | ø9.52 [3/8"] | ø19.05 [3/4"] |
| P201 - P300 | ø9.52 [3/8"] | ø22.2 [7/8"] |
| P301 - P400 | ø12.7 [1/2"] | ø28.58 [1-1/8"] |
| P401 - P650 | ø15.88 [5/8"] | ø28.58 [1-1/8"] |
| P651 - P800 | ø19.05 [3/4"] | ø34.93 [1-3/8"] |
| P801 - | ø19.05 [3/4"] | ø41.28 [1-5/8"] |

(4) Size of the refrigerant pipe between the first distributor and the second distributor

| Liquid pipe size (mm) [inch] | Gas pipe size (mm) [inch] |
|------------------------------|---------------------------|
| ø19.05 [3/4"] | ø34.93 [1-3/8"] |

(5) Size of the refrigerant pipe between the first distributor or the second distributor and outdoor units

| | Liquid pipe size (mm) [inch] | Gas pipe size (mm) [inch] |
|-----------|------------------------------|---------------------------|
| 250 model | ø9.52 [3/8"] | ø22.2 [7/8"] |
| 300 model | ø12.7 [1/2"] | |
| 350 model | | |
| 400 model | ø15.88 [5/8"] | |
| 450 model | | |

* Only applicable to the 500 model and below

III Outdoor Unit Components

| | |
|---|----|
| [1] Outdoor Unit Components and Refrigerant Circuit | 49 |
| [2] Control Box of the Outdoor Unit..... | 51 |
| [3] Outdoor Unit Circuit Board..... | 52 |



[1] Outdoor Unit Components and Refrigerant Circuit

1. Front view of an outdoor unit

(1) PUHY-P200, P250, P300, P350, P400, P450YHA

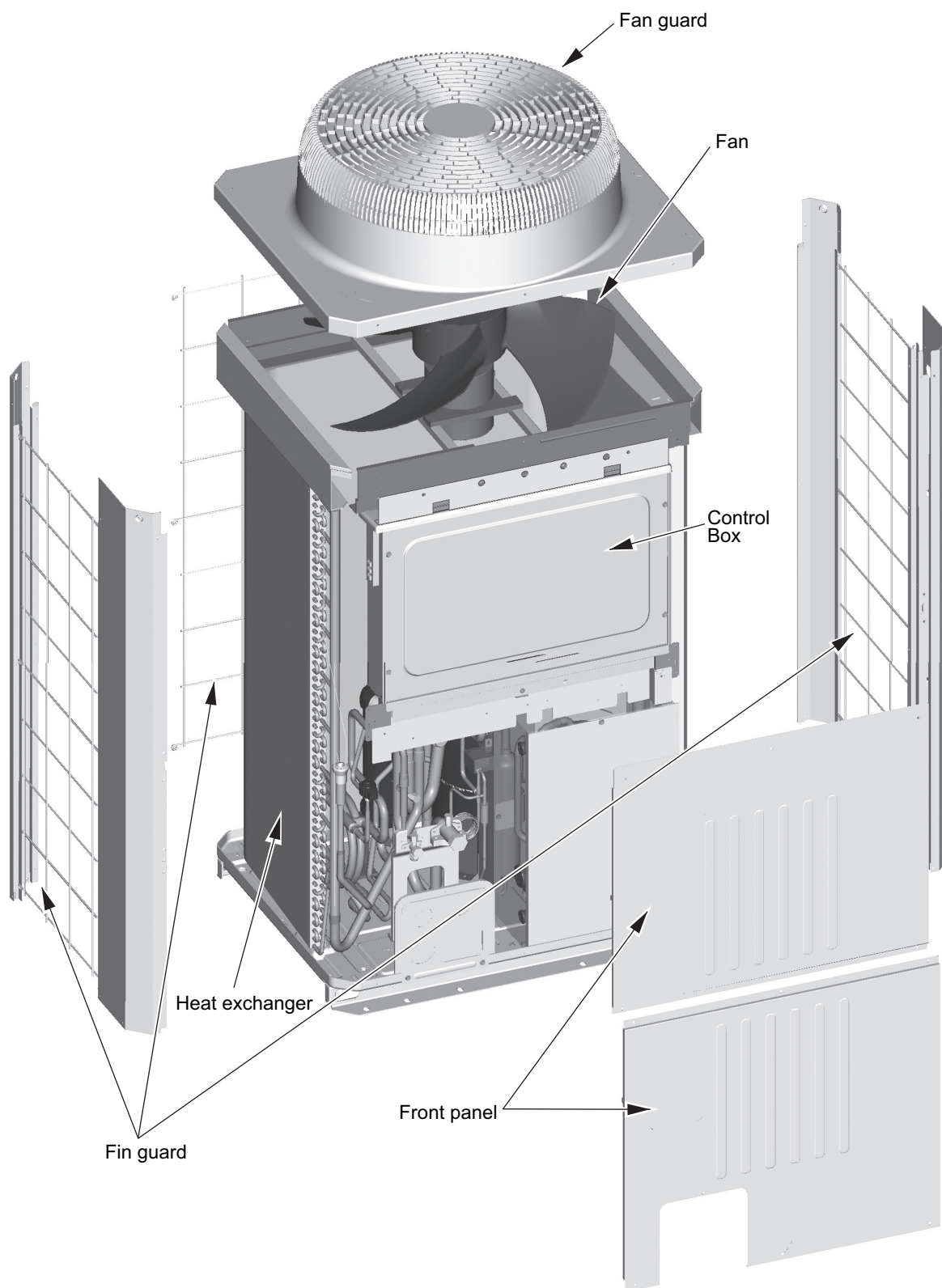

2. Refrigerant circuit

(1) PUHY-P200, P250, P300YHA

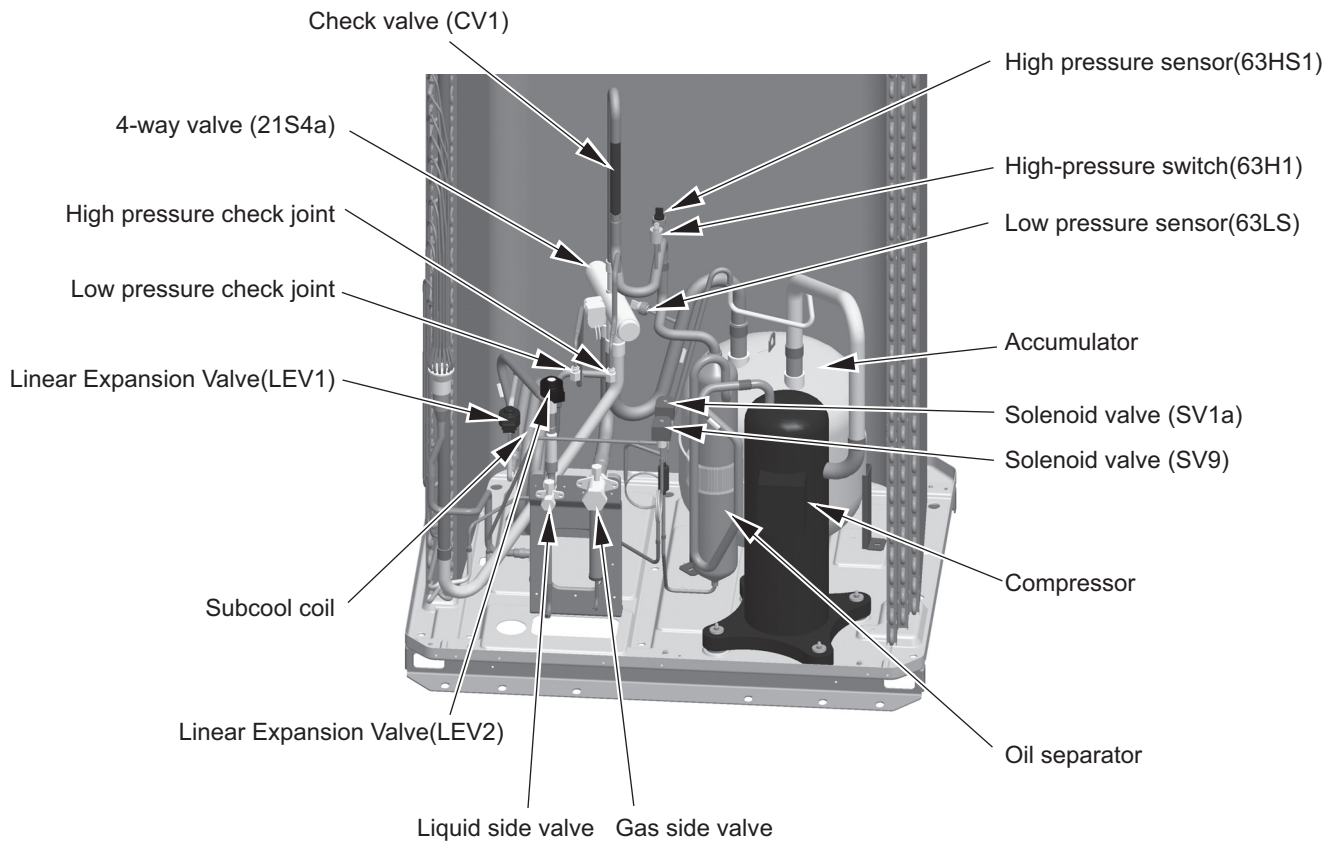

(2) PUHY-P350, P400, P450YHA

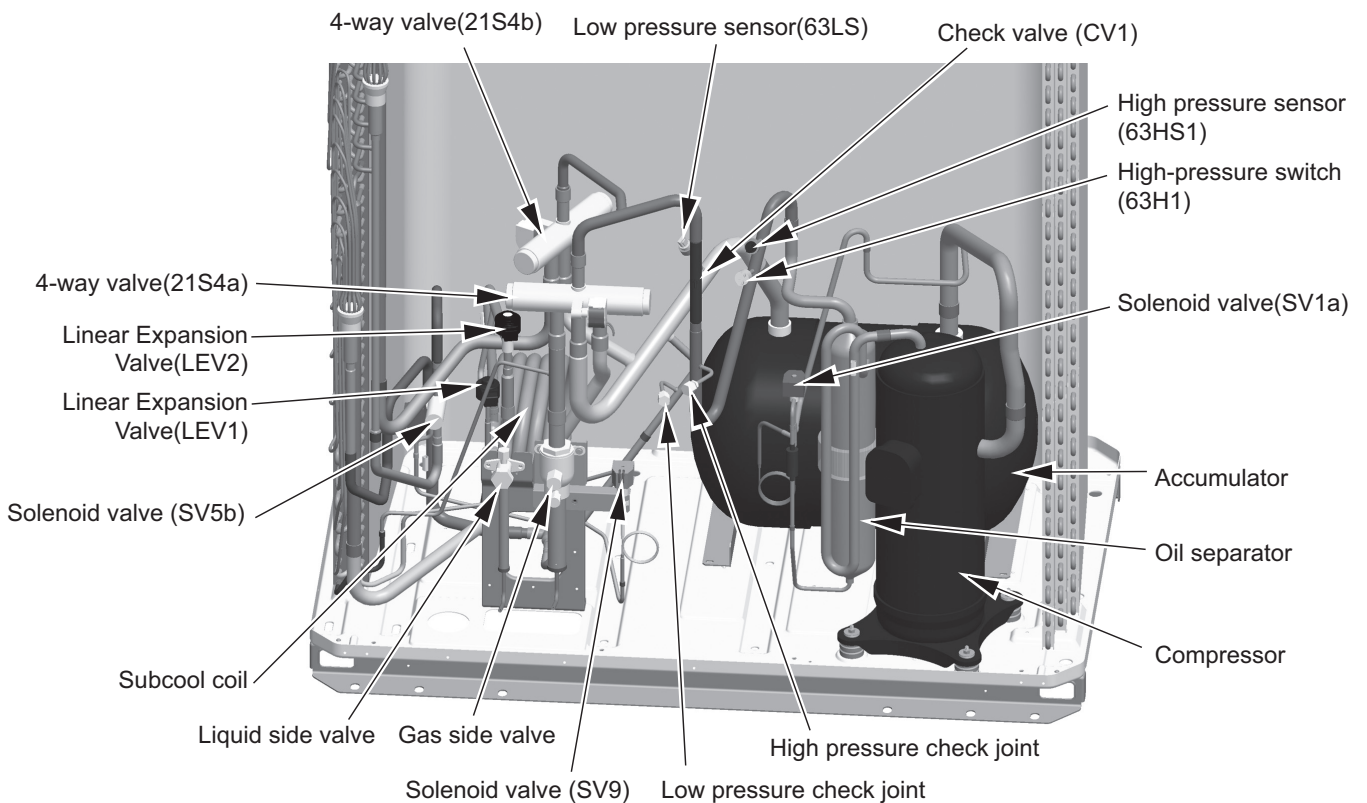

[2] Control Box of the Outdoor Unit

<HIGH VOLTAGE WARNING>

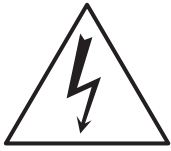

- Control box houses high-voltage parts.
- When opening or closing the front panel of the control box, do not let it come into contact with any of the internal components.
- Before inspecting the inside of the control box, turn off the power, keep the unit off for at least 10 minutes, and confirm that the voltage between FT-P and FT-N on INV Board has dropped to DC20V or less. (It takes about 10 minutes to discharge electricity after the power supply is turned off.)

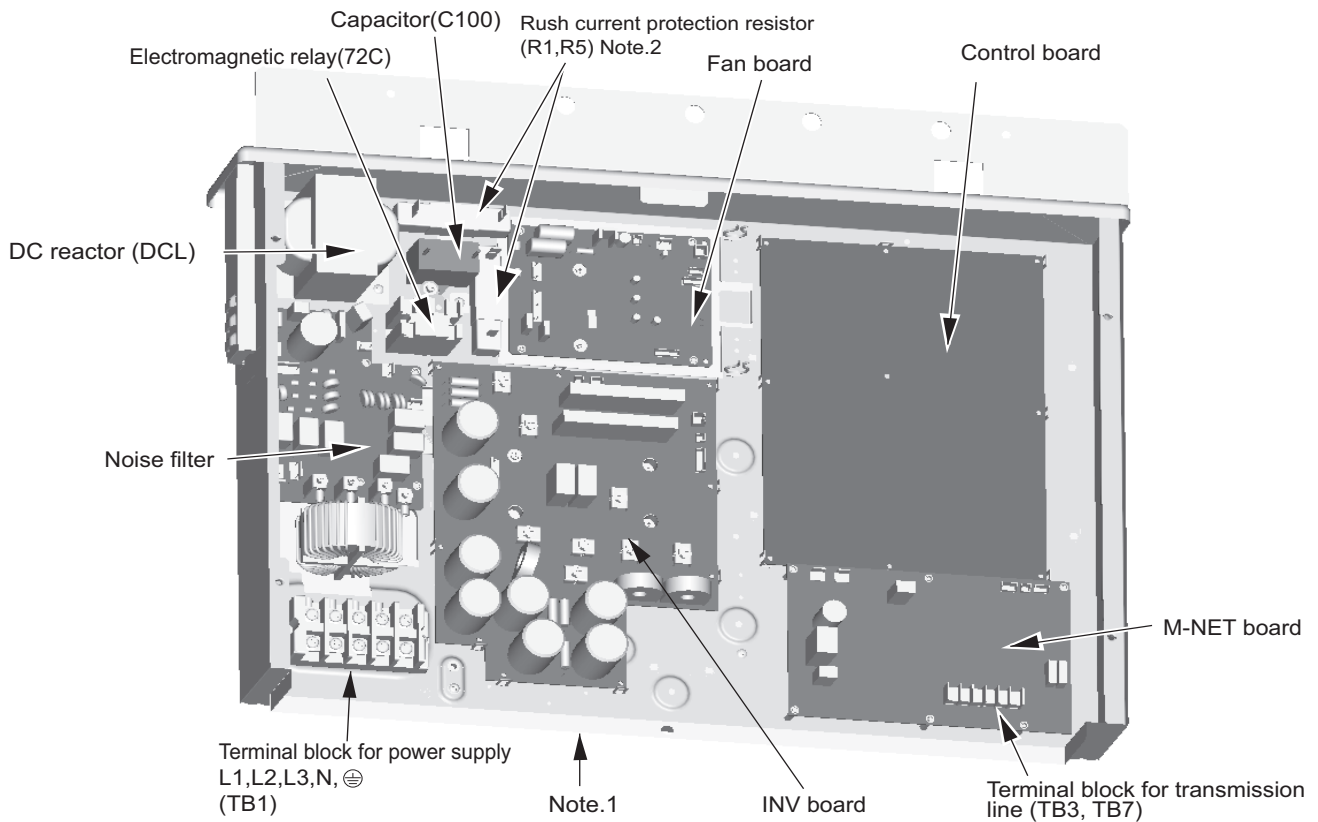

Note

- 1) Exercise caution not to damage the bottom and the front panel of the control box. Damage to these parts affect the water-proof and dust proof properties of the control box and may result in damage to its internal components.
- 2) Faston terminals have a locking function. Make sure the cable heads are securely locked in place. Press the tab on the terminals to remove them.

[3] Outdoor Unit Circuit Board

1. Outdoor unit control board

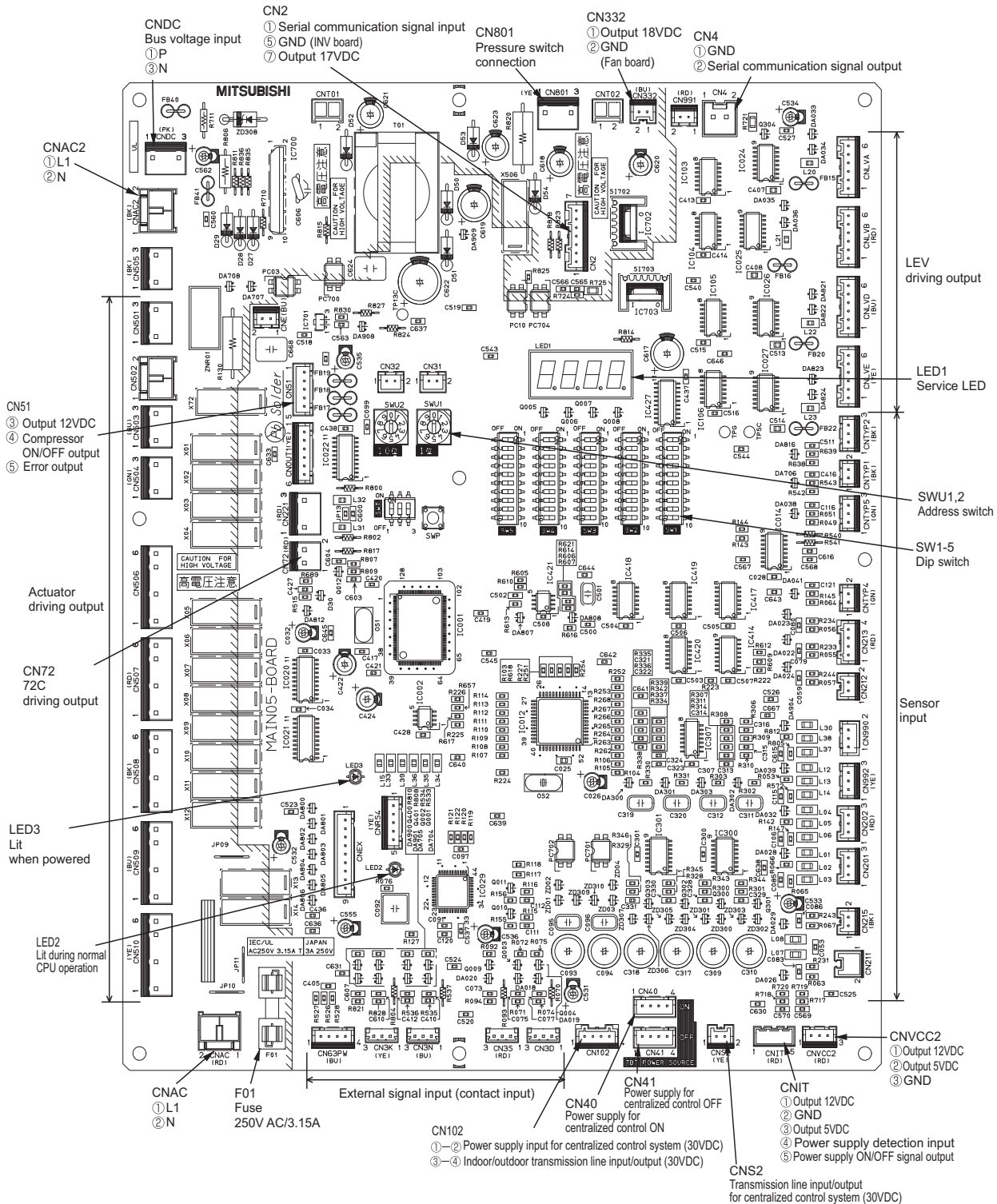

2. M-NET board

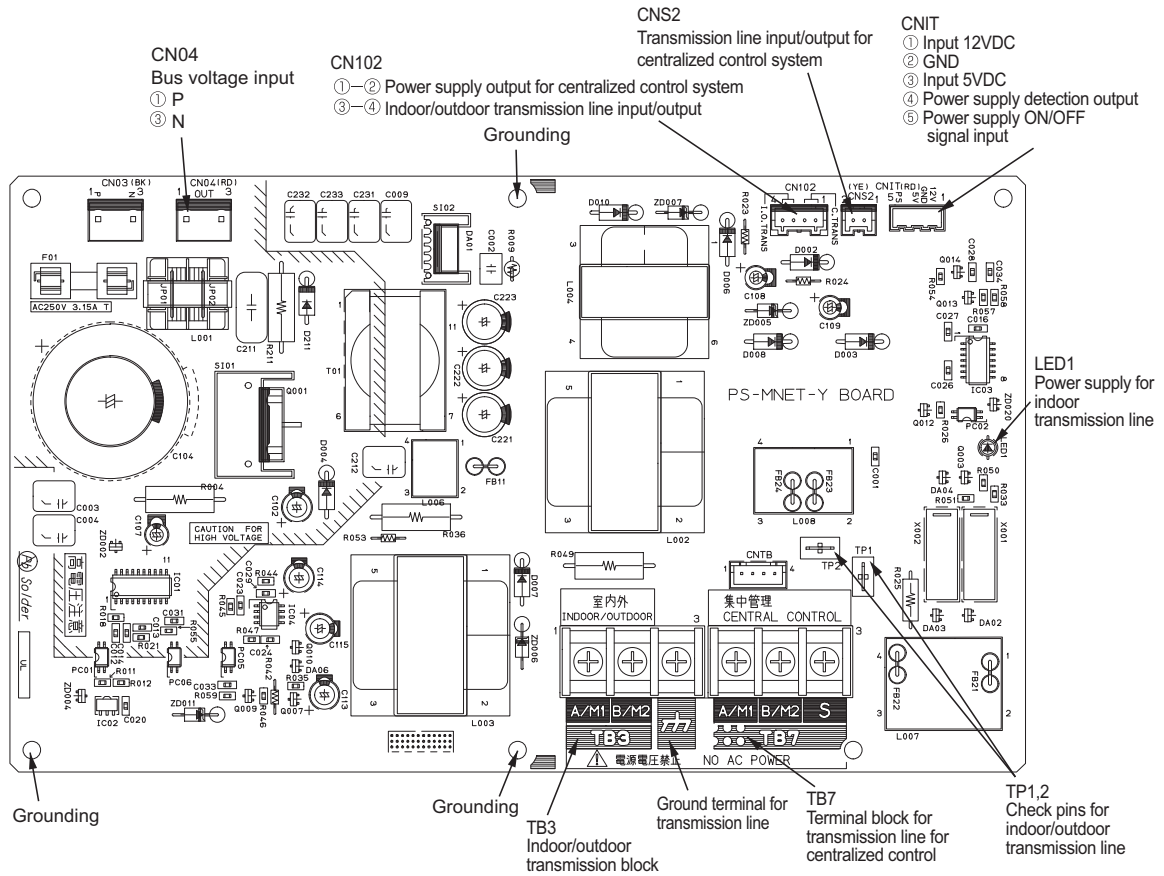

3. INV board

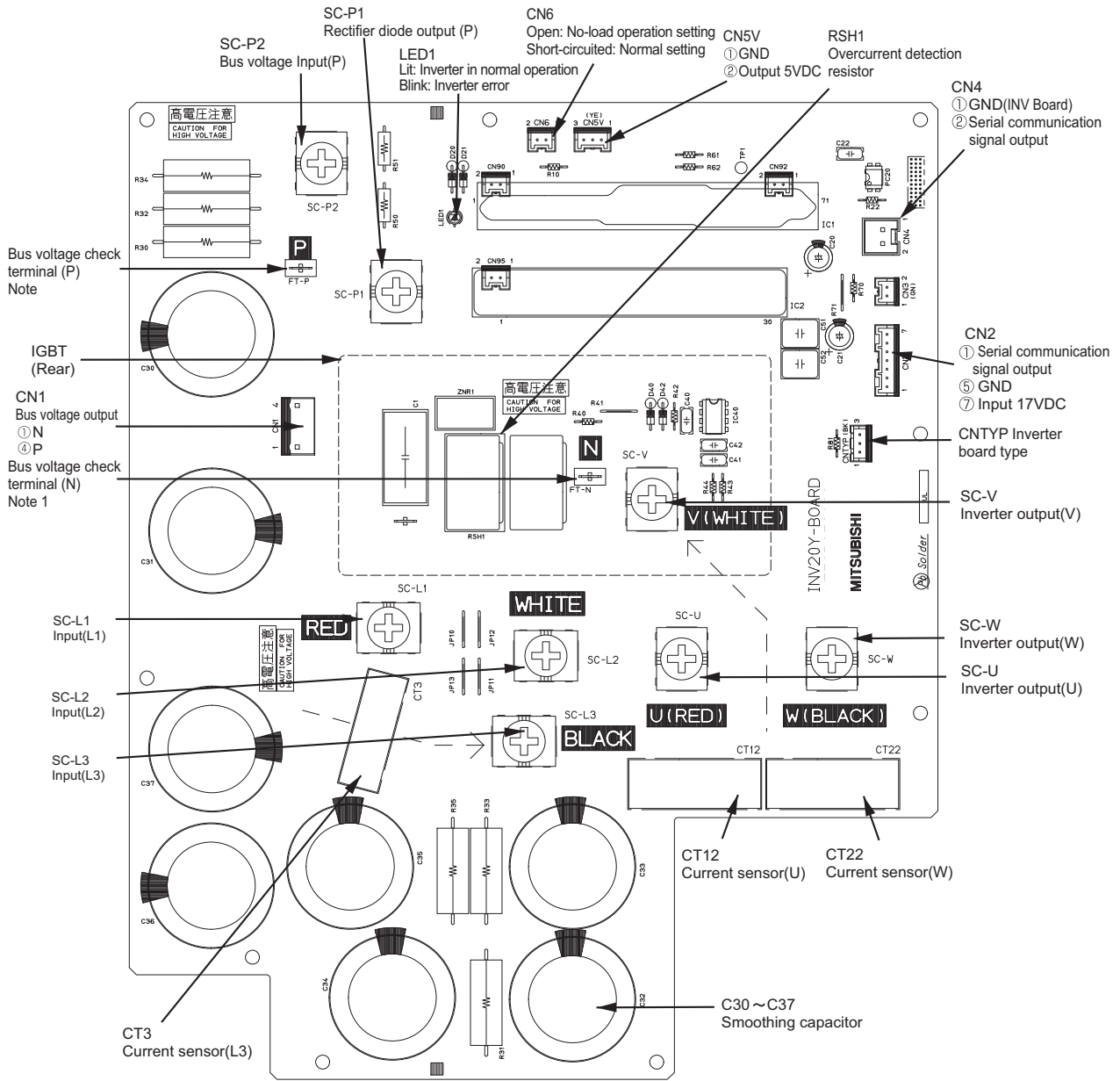

Note

- 1) Before inspecting the inside of the control box, turn off the power, keep the unit off for at least 10 minutes, and confirm that the voltage between FT-P and FT-N on INV Board has dropped to DC20V or less. It takes about 10 minutes to discharge electricity after the power supply is turned off.

4. Fan board

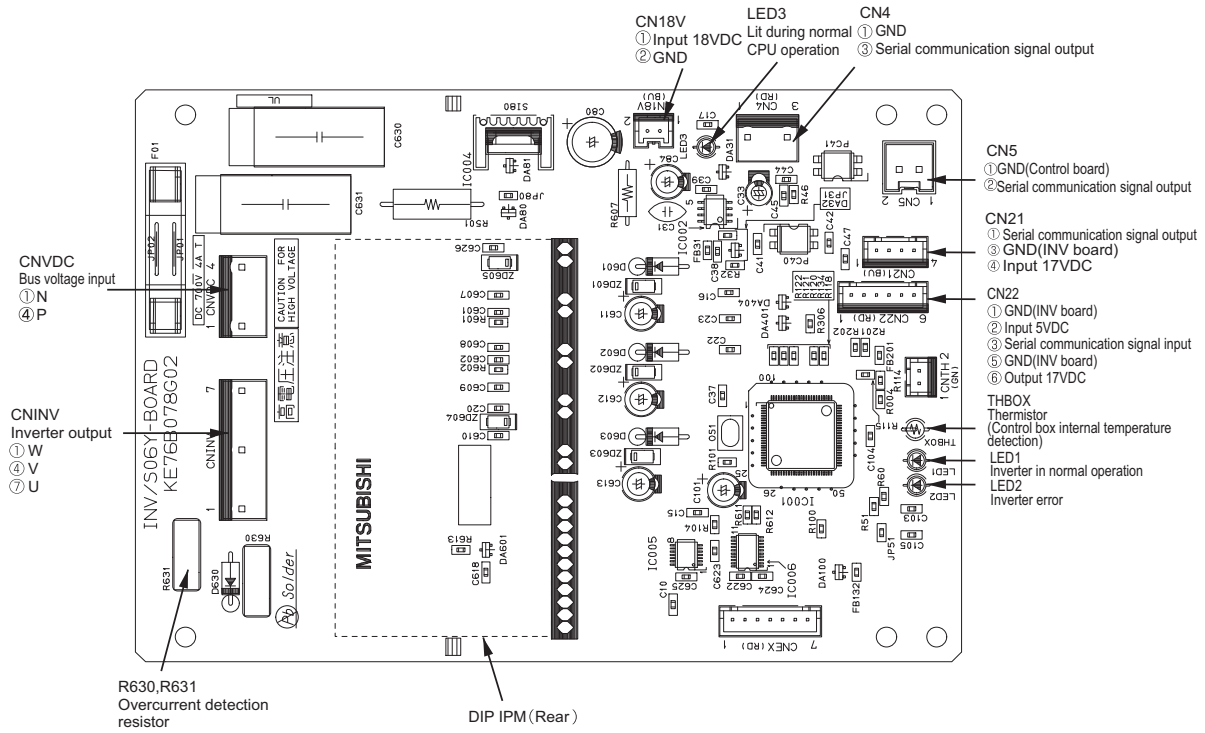

5. Noise Filter

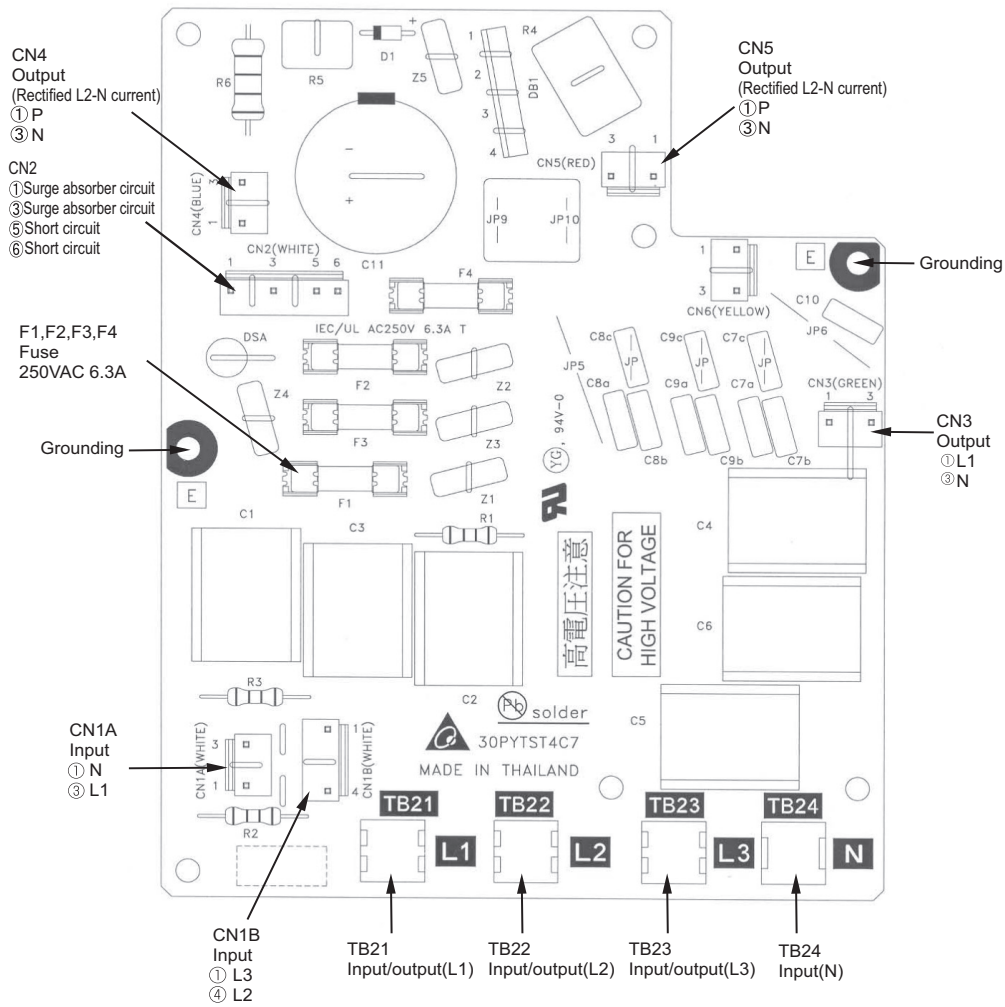

IV Remote Controller

| | |
|--|----|
| [1] Functions and Specifications of MA and ME Remote Controllers | 59 |
| [2] Group Settings and Interlock Settings via the ME Remote Controller | 60 |
| [3] Interlock Settings via the MA Remote Controller | 64 |
| [4] Using the built-in Temperature Sensor on the Remote Controller | 65 |



[1] Functions and Specifications of MA and ME Remote Controllers

There are two types of remote controllers: ME remote controller, which is connected on the indoor-outdoor transmission line, and MA remote controller, which is connected to each indoor unit.

1. Comparison of functions and specifications between MA and ME remote controllers

| Functions/specifications | MA remote controller ^{*1*2} | ME remote controller ^{*2*3} |
|---|--|--|
| Remote controller address settings | Not required | Required |
| Indoor/outdoor unit address settings | Not required (required only by a system with one outdoor unit) ^{*4} | Required |
| Wiring method | Non-polarized 2-core cable *To perform a group operation, daisy-chain the indoor units using non-polarized 2-core cables. | Non-polarized 2-core cable |
| Remote controller connection | Connectable to any indoor unit in the group | Connectable anywhere on the indoor-outdoor transmission line |
| Interlock with the ventilation unit | Each indoor unit can individually be interlocked with a ventilation unit. (Set up via remote controller in the group.) | Each indoor unit can individually be interlocked with a ventilation unit. (Set up via remote controller.) |
| Changes to be made upon grouping change | MA remote controller wiring between indoor units requires rewiring. | Either the indoor unit address and remote controller address must both be changed, or the registration information must be changed via MELANS. |

- *1. MA remote controller refers to MA remote controller (PAR-20MAA, PAR-21MAA), MA simple remote controller, and wireless remote controller.
- *2. Either the MA remote controller or the ME remote controller can be connected when a group operation of units in a system with multiple outdoor units is conducted or when a system controller is connected.
- *3. ME remote controller refers to ME remote controller and ME simple remote controller.
- *4. Depending on the system configuration, some systems with one outdoor unit may require address settings.

2. Remote controller selection criteria

MA remote controller and ME remote controller have different functions and characteristics. Choose the one that better suits the requirements of a given system. Use the following criteria as a reference.

| MA remote controller ^{*1*2} | ME remote controller ^{*1*2} |
|---|--|
| <ul style="list-style-type: none"> ♦There is little likelihood of system expansion and grouping changes. ♦Grouping (floor plan) has been set at the time of installation. | <ul style="list-style-type: none"> ♦There is a likelihood of centralized installation of remote controllers, system expansion, and grouping changes. ♦Grouping (floor plan) has not been set at the time of installation. ♦To connect the remote controller directly to the OA processing unit. |

- *1. ME remote controller and MA remote controller cannot both be connected to the same group of indoor units.
- *2. A system controller must be connected to a system to which both MA remote controller and ME remote controller are connected.

<System with MA remote controller>

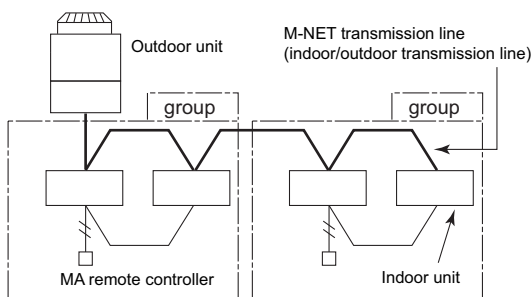

<System with ME remote controllers>

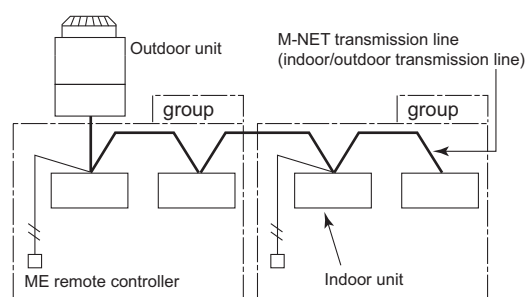

[2] Group Settings and Interlock Settings via the ME Remote Controller

1. Group settings/interlock settings

Make the following settings to perform a group operation of units that are connected to different outdoor units or to manually set up the indoor/outdoor unit address.

- (A) Group settings.....Registration of the indoor units to be controlled with the remote controller, and search and deletion of registered information.
- (B) Interlock settings.....Registration of LOSSNAY units to be interlocked with the indoor units, and search and deletion of registered information

[Operation Procedures]

(1) Address settings

Register the indoor unit to be controlled with the remote controller.

- ① **Bring up either the blinking display of "HO" by turning on the unit or the normal display by pressing the ON/OFF button.**

The display window must look like one of the two figures below to proceed to the next step.

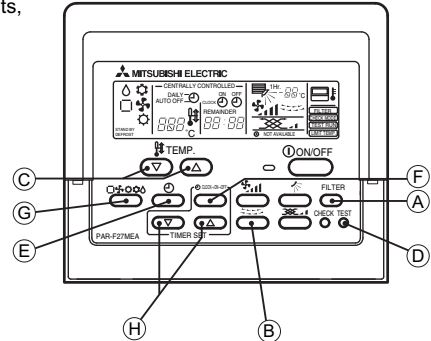

(A) Group Settings

- ② **Bring up the "Group Setting" window.**

- Press and hold buttons (A) [FILTER] and (B) [TIMER SET] simultaneously for 2 seconds to bring up the display as shown below.

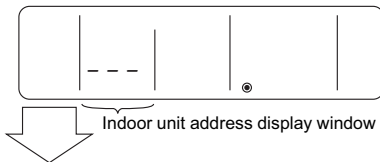

- ③ **Select the unit address.**

- Select the address of the indoor unit to be registered by pressing button (C) [TEMP. (▽) or (△)] to advance or go back through the addresses.

- ④ **Register the indoor unit whose address appears on the display.**

- Press button (D) [TEST] to register the indoor unit address whose address appears on the display.
 - If registration is successfully completed, unit type will appear on the display as shown in the figure below.
 - If the selected address does not have a corresponding indoor unit, an error message will appear on the display. Check the address, and try again.

<Successful completion of registration>

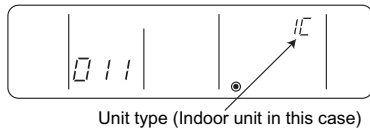

<Deletion error>

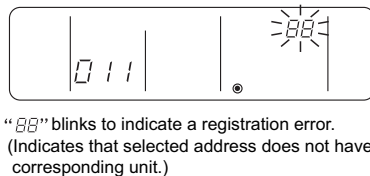

- ⑤ **To register the addresses for multiple indoor units, repeat steps ③ and ④ above.**

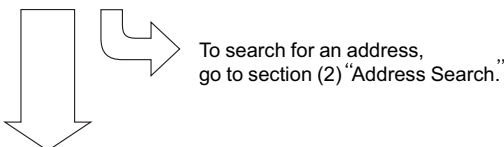

(B) Interlock Settings

- ⑥ **Bring up the "Interlock Setting" window.**

- Press button (G) [FILTER] to bring up the following display. Press again to go back to the "Group Setting" window as shown under step ②.

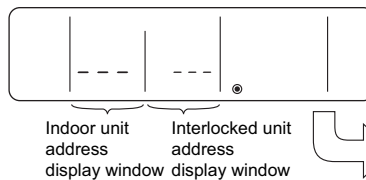

Both the "indoor unit address" and "interlocked unit address" will be displayed together.

To search for an address, go to section (2) "Address Search."

- ⑦ **Bring up the address of the indoor unit and the address of the LOSSNAY to be interlocked on the display.**

- Select the address of the indoor unit to be registered by pressing button (C) [TEMP. (▽) or (△)] to advance or go back through the addresses.
 - Select the address of the LOSSNAY unit to be interlocked by pressing button (H) [TIMER SET (▽) or (△)] to advance or go back through the "interlocked unit addresses."



- ⑧ **Make the settings to interlock LOSSNAY units with indoor units.**

- Press button (D) [TEST] while both the indoor unit address and the address of the LOSSNAY units to be interlocked are displayed to enter the interlock setting.
 - Interlock setting can also be made by bringing up the LOSSNAY address in the indoor unit address display window and the indoor unit address in the interlocked unit address display window.

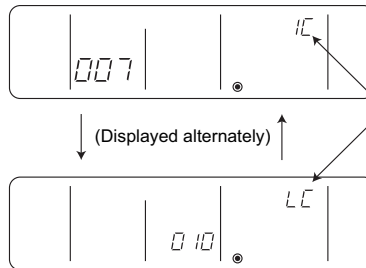

If registration is successfully completed, the two displays as shown on the left will appear alternately.
 If the registration fails, "BB" will blink on the display. (Indicates that the selected address does not have a corresponding unit.)

NOTE : Interlock all the indoor units in the group with the LOSSNAY units; otherwise, the LOSSNAY units will not operate.



(C) To return to the normal display

When all the group settings and interlock settings are made, take the following step to go back to the normal display.

- ⑩ Press and hold buttons **A** [FILTER] and **B** [---] simultaneously for 2 seconds to go back to the window as shown in step ①.



⑨ Repeat steps ⑦ and ⑧ in the previous page to interlock all the indoor units in a group with the LOSSNAY unit.



To go back to the normal display, follow step ⑩.



To search for an address, go to section (2) "Address Search."

(2) Address search

To search for the address of indoor units that have been entered into the remote controller, follow steps ① and ②.

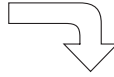

(A) To search group settings



⑪ Bring up the "Group Setting" window.

- Each pressing of button **E** [⊕] will bring up the address of a registered indoor unit and its unit type on the display.

<Entry found>

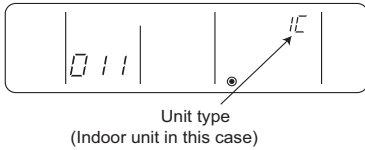

<No entries found>



- When only one unit address is registered, the same address will remain on the display regardless of how many times the button is pressed.
- When the address of multiple units are registered (i.e. "011", "012", "013"), they will be displayed one at a time in an ascending order with each pressing of button **E** [⊕].



To delete an address, go to section (3) "Address Deletion."



To go back to the normal display, follow step ⑩.

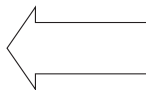

(3) Address deletion

The addresses of the indoor units that have been entered into the remote controller can be deleted by deleting the group settings. The interlock settings between units can be deleted by deleting the interlock settings. Follow the steps in section (2) "Address Search" to find the address to be deleted and perform deletion with the address being displayed in the display window. To delete an address, the address must first be brought up on the display.

⑮ Delete the registered indoor unit address or the interlock setting between units.

- Press button **F** [CLOCK → ON → OFF] twice while either the indoor unit address or the address of the interlocked unit is displayed on the display to delete the interlock setting.

(B) Interlock setting search

After performing step ⑥, proceed as follows:

⑫ Bring up the address of the indoor unit to be searched on the display.

- Select the address of the indoor unit to be searched by pressing button **H** [TIMER SET (▽) or (△)] to advance or go back through the interlocked addresses.



LOSSNAY can be searched in the same manner by bringing up the LOSSNAY address in the Interlocked unit address display window.

⑬ Bring up on the display the address of the LOSSNAY unit that was interlocked with the indoor unit in step ⑫.

- With each pressing of button **E** [⊕], the address of the LOSSNAY and indoor unit that is interlocked with it will be displayed alternately.

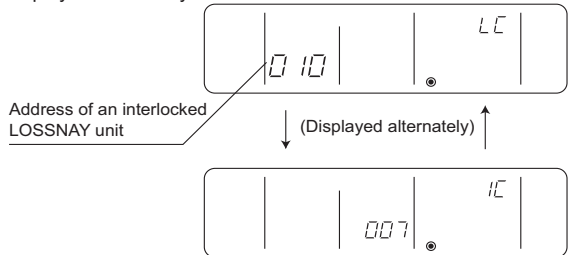

⑭ Bring up the address of another registered unit on the display.

- After completing step ⑬, a subsequent pressing of button **E** [⊕] will bring up the address of another registered unit.

(The display method is the same as the one in step ⑬.)

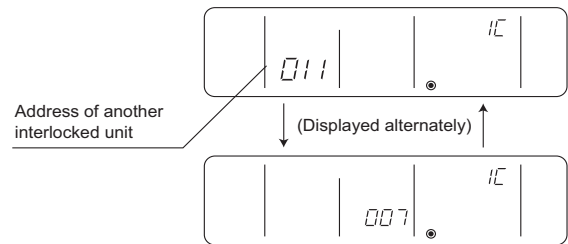

To delete an address, go to section (3) "Address Deletion."



(A) To delete group settings

<Successful completion of deletion>

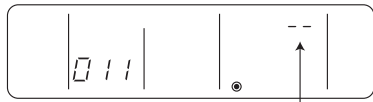

"--" will be displayed in the room temperature display window.

- If a transmission error occurs, the selected setting will not be deleted, and the display will appear as shown below. In this case, repeat the steps above.

<Deletion error>

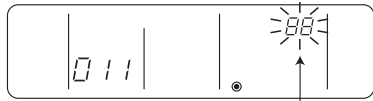

"BB" will be displayed in the room temperature display window.

To go back to the normal display, follow step ⑩.

(B) To delete interlock settings



(Displayed alternately)



If deletion is successfully completed, "--" will appear in the unit type display window. If the deletion fails, "BB" will appear in the unit type display window. In this case, repeat the steps above.

(4) Making (A) Group settings and (B) Interlock settings of a group from any arbitrary remote controller

(A) Group settings and (B) Interlock settings of a group can be made from any arbitrary remote controller. Refer to "(B) Interlock Settings" under section 1 "Group Settings/Interlock Settings" for operation procedures. Set the address as shown below.

(A) To make group settings

Interlocked unit address display window...Remote controller address
Indoor unit address display window.....The address of the indoor unit to be controlled with the remote controller

(B) To make interlock settings

Interlocked unit address display window...LOSSNAY address
Indoor unit address display window.....The address of the indoor unit to be interlocked with the LOSSNAY

2. Remote controller function selection via the ME remote controller

In the remote controller function selection mode, the settings for four types of functions can be made or changed as necessary.

- 1) Skip-Auto-Mode setting
The automatic operation mode that is supported by some simultaneous cooling/heating type units can be made unselectable via the ME remote controller.
- 2) Operation mode display selection mode (Display or non-display of COOL/HEAT during automatic operation mode)
When the automatic operation mode is selected, the indoor unit will automatically perform a cooling or heating operation based on the room temperature. In this case, " " or " " will appear on the remote controller display. This setting can be changed so that only " " will appear on the display.
- 3) Room temperature display selection mode (Display or non-display of room temperature)
Although the suction temperature is normally displayed on the remote controller, the setting can be changed so that it will not appear on the remote controller.
- 4) Narrowed preset temperature range mode
The default temperature ranges are 19°C to 30°C in the cooling/dry mode and 17°C to 28°C in the heating mode and 19°C to 28°C in the auto mode. By changing these ranges (raising the lower limit for the cooling/dry mode and lowering the upper limit for the heating mode), energy can be saved.

NOTE

When making the temperature range setting on the simultaneous cooling/heating type units that supports the automatic operation mode to save on energy consumption, enable the Skip-Auto-Mode setting to make the automatic operation mode unselectable. If the automatic operation mode is selected, the energy-saving function may not work properly.

When connected to the air conditioning units that do not support the automatic operation mode, the setting for the Skip-Auto-Mode, restricted preset temperature range mode (AUTO), and operation mode display selection mode are invalid. If an attempt is made to change the preset temperature range, "LIMIT TEMP." appears on the display.

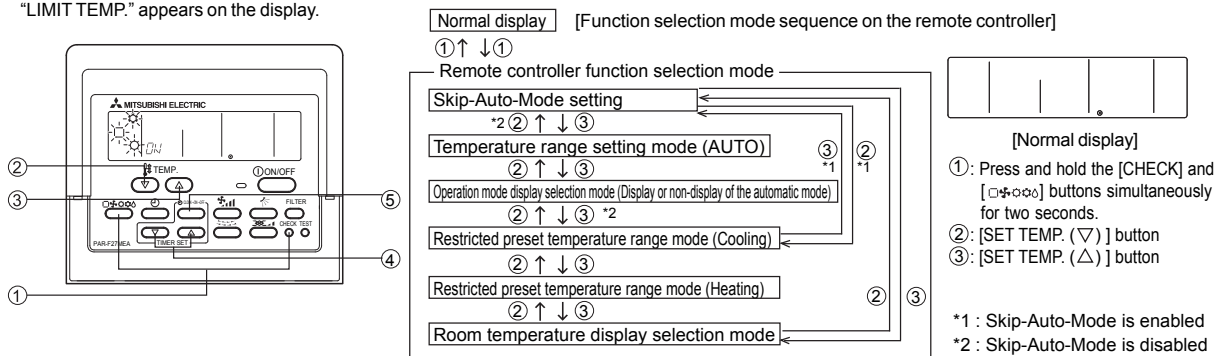

[Operation Procedures]

1. Press the [ON/OFF] button on the remote controller to bring the unit to a stop. The display will appear as shown in the previous page (Normal display).
2. Press buttons ① [CHECK] and [] simultaneously for 2 seconds to go into the "Skip-Auto-Mode setting." under the remote controller function selection mode. Press button ② [SET TEMP. (∇)] or ③ [SET TEMP. (Δ)] to go into the other four modes under the remote controller function selection mode.

Skip-Auto-Mode setting (Making the automatic operation mode unselectable)

This setting is valid only when the controller is connected to the simultaneous cooling/heating type air conditioning units that support the automatic operation mode.

- " " blinks and either "ON" or "OFF" lights up on the controller. Pressing the ④ [TIMER SET (Δ) or (∇)] button switches between "ON" and "OFF."

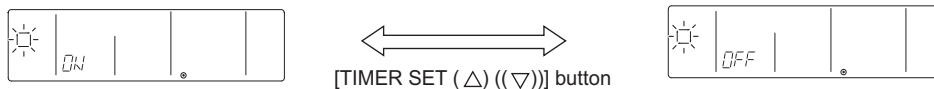

- When set to "ON," the automatic operation mode is available for selection in the function selection mode.
- When set to "OFF," the automatic operation mode is not available for selection in the function selection mode, and an automatic operation cannot be performed. (The automatic operation mode is skipped in the function selection mode sequence.)

Operation mode display selection mode (Changing the type of display that appears during the automatic mode operation)

- When connected to the air conditioning units that do not support the automatic operation mode, the setting for this mode is invalid.
- " " " " will blink, and either "ON" or "OFF" will light up. Press button ④ [TIMER SET (Δ) or (∇)] in this state to switch between "ON" and "OFF."

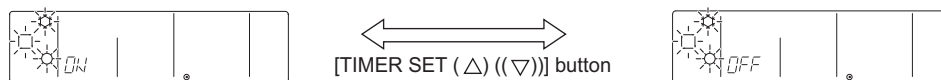

- When it is set to "ON," " " " " will appear on the display during automatic operation mode.
- When it is set to "OFF," only " " will appear on the display during automatic operation mode.

Restricted preset temperature range mode (The range of preset temperature can be changed.)

1) Temperature range setting for the cooling/dry mode

" / " will light up in the display window, and the temperature range for the cooling/dry mode will appear on the display.

[Lower limit temperature]: Appears in the preset temperature display window [Upper limit temperature: Appears in the time display window
Switch between the Lower and Upper limit temperature setting by pressing the ⑤ [CLOCK-ON-OFF] button. The selected temperature setting blinks.

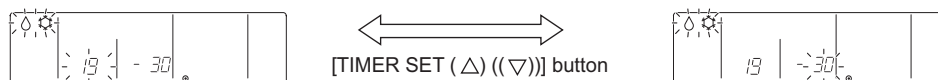

[The left figure shows the display that appears when the current temperature range setting is between 19°C and 30°C in the Cool/Dry mode, and the lower limit temperature is selected to be set.]

Press button ④ [TIMER SET (Δ) or (∇)] to set the lower limit temperature to the desired temperature.

[Settable range for the lower limit temperature] : 19°C ↔ 30°C (Settable up to the upper limit temperature that is shown on the display)

[Settable range for the upper limit temperature] : 30°C ↔ 19°C (Settable up to the lower limit temperature that is shown on the display)

2) Temperature range setting for heating

" " and the settable temperature range for heating appear on the display.

As with the Cool/Dry mode, use the ⑤ [CLOCK-ON-OFF] button and the ④ [TIMER SET (Δ) or (∇)] to set the temperature range.

[Settable range for the lower limit temperature] : 17°C ↔ 28°C (Settable up to the upper limit temperature that is shown on the display)

[Settable range for the upper limit temperature] : 28°C ↔ 17°C (Settable up to the lower limit temperature that is shown on the display)

3) Temperature range setting for the automatic mode

When connected to the air conditioning units that do not support the automatic operation mode, the setting for this mode is invalid.

" " and the temperature range for the automatic operation mode appear on the display.

As with the Cool/Dry mode, use the ⑤ [CLOCK-ON-OFF] button and the ④ [TIMER SET (Δ) or (∇)] to set the temperature range.

[Settable range for the lower limit temperature] : 19°C ↔ 28°C (Settable up to the upper limit temperature that is shown on the display)

[Settable range for the upper limit temperature] : 28°C ↔ 19°C (Settable up to the lower limit temperature that is shown on the display)

Room temperature display selection mode (Switching between the display or non-display of room temperature on the controller)

- " 88°C " blinks and either "ON" or "OFF" lights up on the controller. Pressing the ④ [TIMER SET (Δ) or (∇)] button switches between "ON" and "OFF."

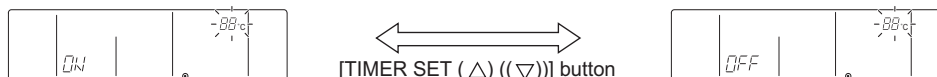

- When set to "ON," room temperature always appears on the display during operation.
When set to "OFF," room temperature does not appear on the display during operation.

[3] Interlock Settings via the MA Remote Controller

1. LOSSNAY interlock setting (Make this setting only when necessary.)

Make this setting only when necessary.

Perform this operation to enter the interlock setting between the LOSSNAY and the indoor units to which the remote controller is connected, or to search and delete registered information.
 In the following example, the address of the indoor unit is 05 and the address of the LOSSNAY unit is 30.

[Operation Procedures]

- Press the [ON/OFF] button on the remote controller to bring the unit to a stop.
 The display window on the remote controller must look like the figure below to proceed to step ②.

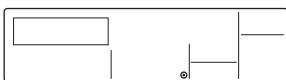

- Press and hold the [FILTER] and [] buttons simultaneously for two seconds to perform a search for the LOSSNAY that is interlocked with the indoor unit to which the remote controller is connected.

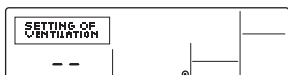

- Search result
 - The indoor unit address and the interlocked LOSSNAY address will appear alternately.

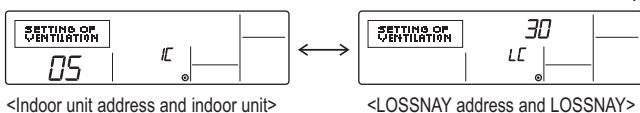

- Without interlocked LOSSNAY settings



- If no settings are necessary, exit the window by pressing and holding the [FILTER] and [] buttons simultaneously for 2 seconds.
 Go to step 1. **Registration Procedures** to make the interlock settings with LOSSNAY units, or go to step 2. **Search Procedures** to search for a particular LOSSNAY unit.
 Go to step 3. **Deletion Procedures** to delete any LOSSNAY settings.

< 1. Registration Procedures >

- To interlock an indoor unit with a LOSSNAY unit, press the [TEMP. (▽) or (△)] button on the remote controller that is connected to the indoor unit, and select its address (01 to 50).
- Press the [CLOCK (▽) or (△)] button to select the address of the LOSSNAY to be interlocked (01 to 50).

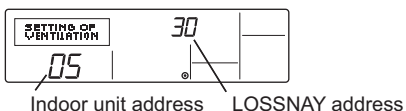

Indoor unit address LOSSNAY address

- Press the [TEST] button to register the address of the selected indoor unit and the interlocked LOSSNAY unit.
 - Registration completed
 The registered indoor unit address and "IC," and the interlocked LOSSNAY address and "LC" will appear alternately.

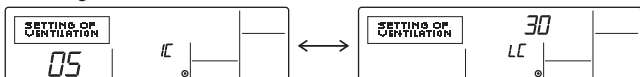

- Registration error
 If the registration fails, the indoor unit address and the LOSSNAY address will be displayed alternately.



Registration cannot be completed: The selected unit address does not have a corresponding indoor unit or a LOSSNAY unit.
 Registration cannot be completed: Another LOSSNAY has already been interlocked with the selected indoor unit.

< 2. Search Procedures >

⑧ To search for the LOSSNAY unit that is interlocked with a particular indoor unit, enter the address of the indoor unit into the remote controller that is connected to it.

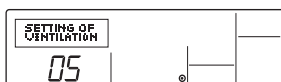

<Indoor unit address>

⑨ Press the [⊖ MENU] button to search for the address of the LOSSNAY unit that is interlocked with the selected indoor unit.

- Search completed (With a LOSSNAY connection)

The indoor unit address and “ IC,” and the interlocked LOSSNAY address and “ LC ” will appear alternately.

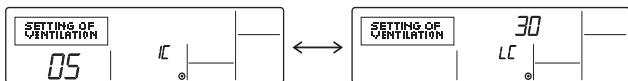

- Search completed (No interlocked settings with a LOSSNAY exist.)



- The selected address does not have a corresponding indoor unit.

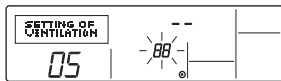

< 3. Deletion Procedures >

Take the following steps to delete the interlock setting between a LOSSNAY unit and the interlocked indoor unit from the remote controller that is connected to the indoor unit.

⑩ Find the address of the LOSSNAY to be deleted (See section 2. Search Procedures.), and bring up the result of the search for both the indoor unit and LOSSNAY on the display.

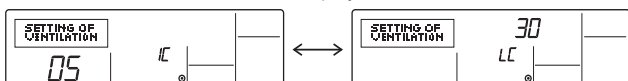

⑪ Press the [⊕ ON/OFF] button twice to delete the address of the LOSSNAY unit that is interlocked with the selected indoor unit.

- Registration completed

The indoor unit address and “ --,” and the interlocked LOSSNAY address and “ -- ” will appear alternately.

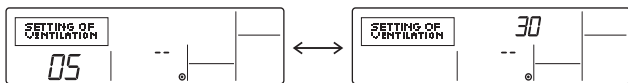

-Deletion error

If the deletion fails

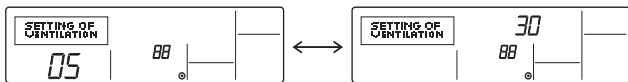

[4] Using the built-in Temperature Sensor on the Remote Controller

1. Selecting the position of temperature detection (Factory setting: SW1-1 on the controller board on the indoor unit is set to OFF.)

To use the built-in sensor on the remote controller, set the SW1-1 on the controller board on the indoor unit to ON.

♦ Some models of remote controllers are not equipped with a built-in temperature sensor. Use the built-in temperature sensor on the indoor unit instead.

♦ When using the built-in sensor on the remote controller, install the remote controller where room temperature can be detected.

V Electrical Wiring Diagram

| | |
|---|----|
| [1] Electrical Wiring Diagram of the Outdoor Unit | 69 |
| [2] Electrical Wiring Diagram of Transmission Booster | 70 |



[1] Electrical Wiring Diagram of the Outdoor Unit

1. Electrical wiring diagram of the outdoor unit

(1) PUHY-P200, P250, P300, P350, P400, P450 models

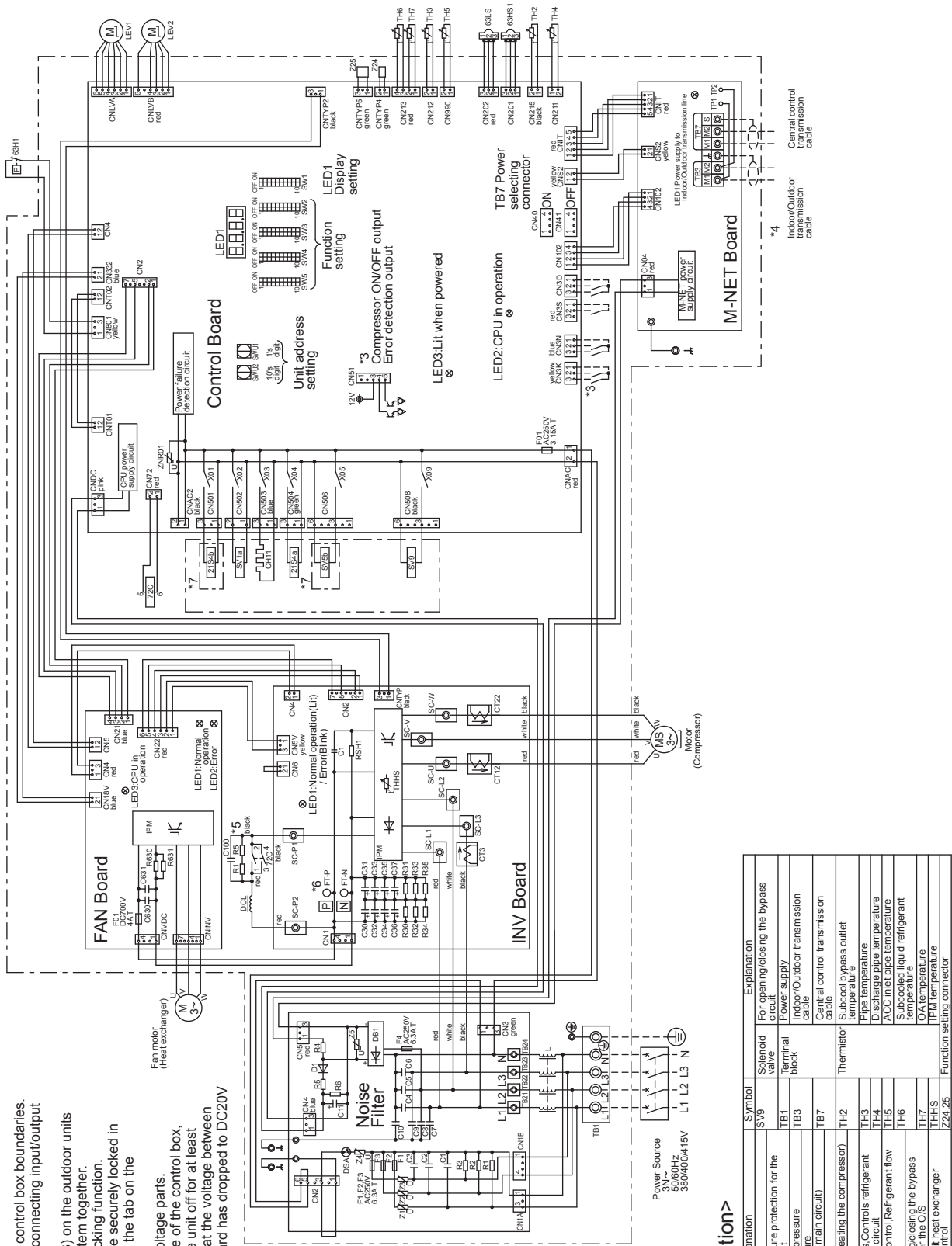

<Symbol explanation>

| Symbol | Explanation | Symbol | Explanation |
|------------|---|--------|---|
| Z1S4a,b | 4-way valve | SV9 | Solenoid valve |
| 63H1 | Pressure switch | TH1 | High pressure protection for the outdoor unit |
| 63HS1 | Pressure switch | TB3 | Terminal block |
| 63LS | Pressure switch | TB7 | Discharge pressure |
| 63T12,22,3 | Compressor (A/C) | TH2 | Thermistor |
| CH11 | Crankcase heater (for heating the compressor) | TH3 | Subcool bypass outlet |
| DCL | DC reactor | TH4 | Pipe temperature |
| LEV1 | Linear expansion valve | TH5 | Discharge pipe temperature |
| LEV2 | Linear expansion valve | TH6 | ACC inlet pipe temperature |
| SV1a | Solenoid valve | TH7 | Subcooled liquid refrigerant temperature |
| SV5b | Solenoid valve | THHS | O/A temperature |
| | | Z24,25 | IPM temperature |
| | | | Function setting connector |

- *1. Single-dotted lines indicate wiring not supplied with the unit.
- *2. Dot-dash lines indicate the control box boundaries.
- *3. Refer to the Data book for connecting input/output signal connectors.
- *4. Daisy-chain terminals (TB3) on the outdoor units in the same refrigerant system together.
- *5. Faston terminals have a locking function. Make sure the terminals are securely locked in place after insertion. Press the tab on the terminals to remove them.
- *6. Control box houses high-voltage parts. Before inspecting the inside of the control box, turn off the power, keep the unit off for at least 10 minutes, and confirm that the voltage between FT-P and FT-N on INV Board has dropped to DC20V or less.
- *7. Difference of appliance

| Model name | Appliance |
|----------------|-----------------|
| P200/P250/P300 | 17 do not exist |
| P350/P400/P450 | 17 exist |

[2] Electrical Wiring Diagram of Transmission Booster

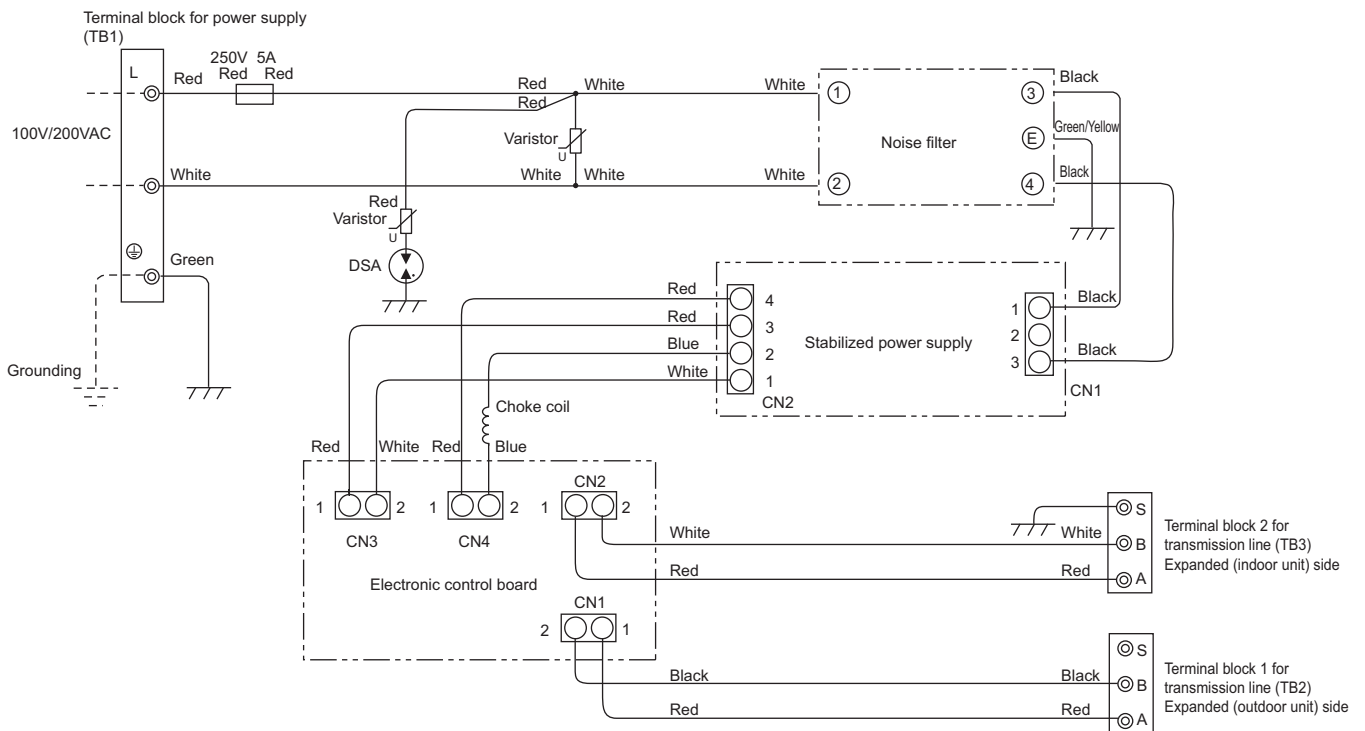

VI Refrigerant Circuit

| | |
|---|----|
| [1] Refrigerant Circuit Diagram | 73 |
| [2] Principal Parts and Functions | 74 |



[1] Refrigerant Circuit Diagram

1. Outdoor unit

(1) PUHY-P200, P250, P300 models

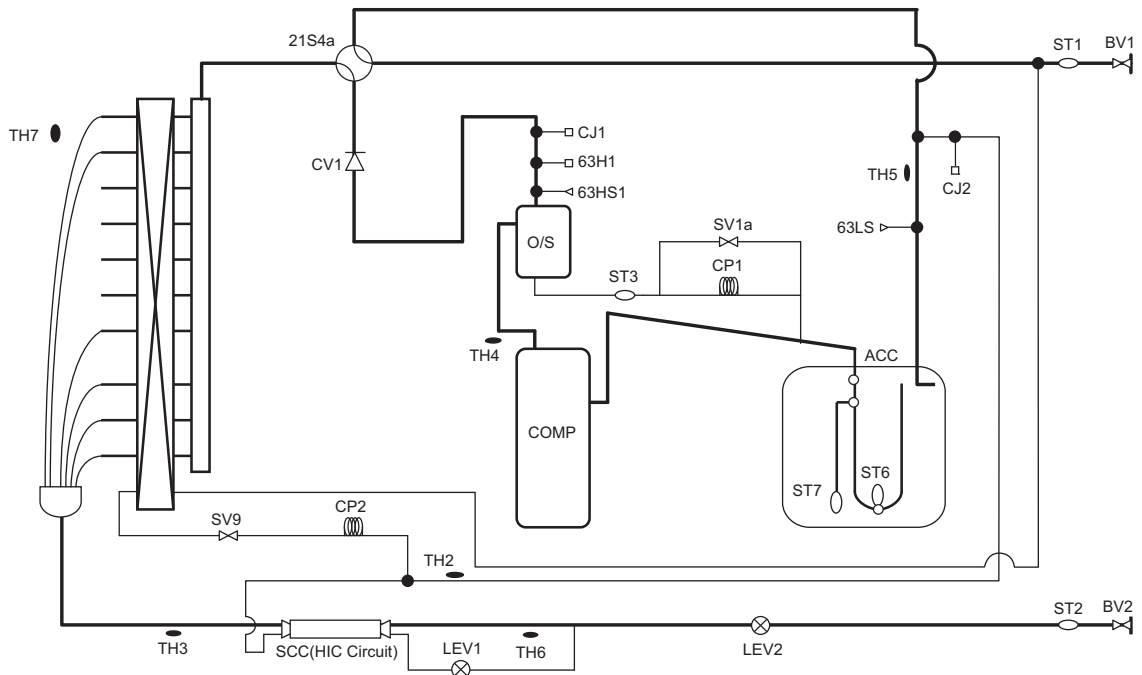

(2) PUHY-P350, P400, P450 models

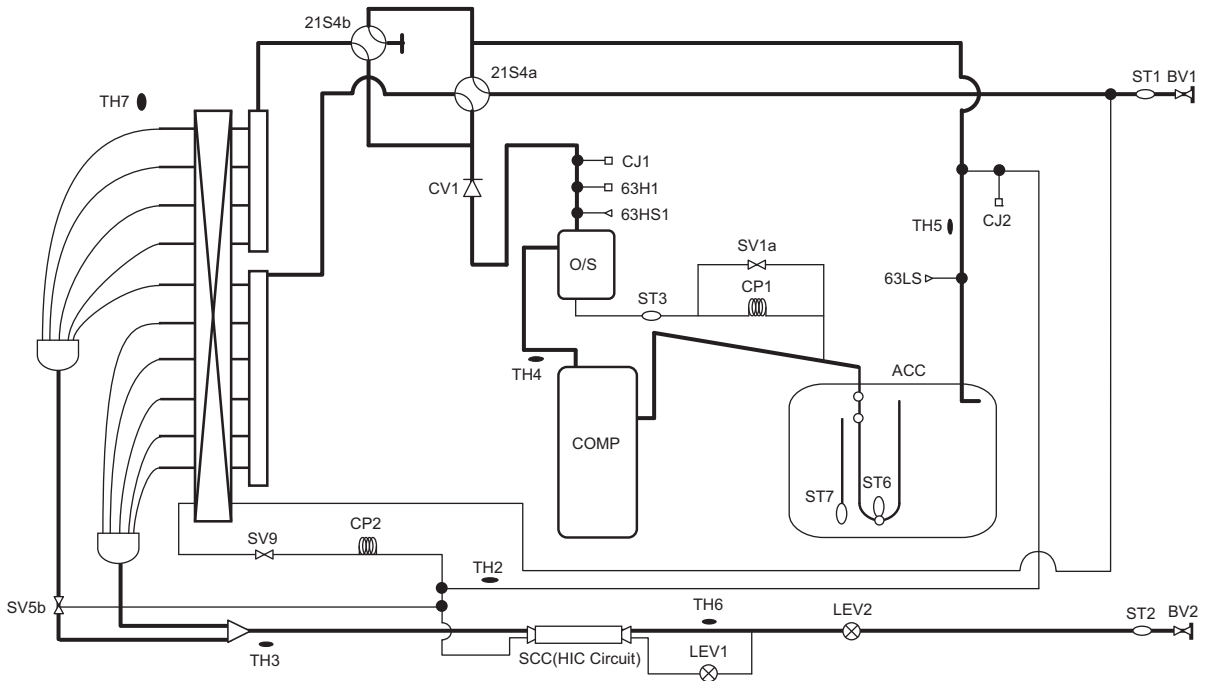

[2] Principal Parts and Functions

1. Outdoor unit

| Part name | Symbols (functions) | Notes | Usage | Specifications | Check method |
|----------------------|---------------------|-------|---|--|--------------|
| Com-pressor | MC1 (Comp1) | | Adjusts the amount of circulating refrigerant by adjusting the operating frequency based on the operating pressure data | P200 - 250 models Low-pressure shell scroll compressor Wirewound resistance 20°C[68°F] : 0.71ohm P300 - 450 models Low-pressure shell scroll compressor Wirewound resistance 20°C[68°F] : 0.323ohm | |
| High pressure sensor | 63HS1 | | 1) Detects high pressure 2) Regulates frequency and provides high-pressure protection | <p>63HS1</p> <p>Pressure 0~4.15 MPa [601psi] Vout 0.5~3.5V 0.071V/0.098 MPa [14psi] Pressure [MPa] =1.38 x Vout [V]-0.69 Pressure [psi] =(1.38 x Vout [V] - 0.69) x 145</p> <p>1 GND (Black) 2 Vout (White) 3 Vcc (DC5V) (Red)</p> | |
| Low pressure sensor | 63LS | | 1) Detects low pressure 2) Provides low-pressure protection | <p>63LS</p> <p>Pressure 0~1.7 MPa [247psi] Vout 0.5~3.5V 0.173V/0.098 MPa [14psi] Pressure [MPa] =0.566 x Vout [V] - 0.283 Pressure [psi] =(0.566 x Vout [V] - 0.283) x 145</p> <p>1 GND (Black) 2 Vout (White) 3 Vcc (DC5V) (Red)</p> | |
| Pres-sure switch | 63H1 | | 1) Detects high pressure 2) Provides high-pressure protection | 4.15MPa[601psi] OFF setting | |

| Part name | Symbols (functions) | Notes | Usage | Specifications | Check method |
|----------------|--------------------------------------|-------------------------|--|---|--------------------------------|
| Thermistor | TH4 (Discharge) | | 1) Detects discharge air temperature 2) Provides high-pressure protection 0°C[32°F] :698kohm 10°C[50°F] :413kohm 20°C[68°F] :250kohm 30°C[86°F] :160kohm 40°C[104°F] :104kohm 50°C[122°F] : 70kohm 60°C[140°F] : 48kohm 70°C[158°F] : 34kohm 80°C[176°F] : 24kohm 90°C[194°F] :17.5kohm 100°C[212°F] :13.0kohm 110°C[230°F] : 9.8kohm | Degrees Celsius $R_{120} = 7.465k\Omega$ $R_{25/120} = 4057$ $R_t = 7.465 \exp\{4057(\frac{1}{273+t} - \frac{1}{393})\}$ | Resistance check |
| | TH2 | | LEV 1 is controlled based on the TH2, TH3, and TH6 values. | Degrees Celsius $R_0 = 15k\Omega$ $R_{0/80} = 3460$ $R_t = 15 \exp\{3460 (\frac{1}{273+t} - \frac{1}{273})\}$ | Resistance check |
| | TH3 (Pipe temperature) | | 1) Controls frequency 2) Controls defrosting during heating operation 3) Detects subcool at the heat exchanger outlet and controls LEV1 based on HPS data and TH3 data | 0°C[32°F] :15kohm 10°C[50°F] :9.7kohm 20°C[68°F] :6.4kohm 25°C[77°F] :5.3kohm 30°C[86°F] :4.3kohm 40°C[104°F] :3.1kohm | |
| | TH7 (Outdoor temperature) | | 1) Detects outdoor air temperature 2) Controls fan operation | | |
| | TH5 | | LEV2 is controlled based on the 63LS and TH5 values. | | |
| | TH6 | | Controls LEV1 based on TH2, TH3, and TH6 data. | | |
| | THHS Inverter heat sink temperature | | Controls inverter cooling fan based on THHS temperature | Degrees Celsius $R_{50} = 17k\Omega$ $R_{25/120} = 4016$ $R_t = 17 \exp\{4016 (\frac{1}{273+t} - \frac{1}{323})\}$ | |
| Solenoid valve | SV1a Discharge-suction bypass | | 1) High/low pressure bypass at start-up and stopping, and capacity control during low-load operation 2) High-pressure-rise prevention | AC208-230V Open while being powered/ closed while not being powered | Continuity check with a tester |
| | SV5b Heat exchanger capacity control | P350 - P450 models only | Controls outdoor unit heat exchanger capacity | AC208-230V Closed while being powered/ open while not being powered. | |
| | SV9 | | High-pressure-rise prevention | Open while being powered/ closed while not being powered | |

[VI Refrigerant Circuit]

| Part name | Symbols (functions) | Notes | Usage | Specifications | Check method |
|------------------------|------------------------------------|-------------------------|---|--|--|
| Linear expansion valve | LEV1 (SC control) | | Adjusts the amount of bypass flow from the liquid pipe on the outdoor unit during cooling | DC12V Opening of a valve driven by a stepping motor 0-480 pulses (direct driven type) | Same as indoor LEV The resistance value differs from that of the indoor LEV. (Refer to the section "LEV Troubleshooting.") (page 226) |
| | LEV2 (Refrigerant flow adjustment) | | Adjusts refrigerant flow during heating | DC12V Opening of a valve driven by a stepping motor 2100 pulses (Max. 3000 pulses) | Same as indoor LEV |
| Heater | CH11 | | Heats the refrigerant in the compressor | Cord heater AC230V P200 - P250 models 1511 ohm 35W P300 - P450 models 1176 ohm 45W | Resistance check |
| 4-way valve | 21S4a | | Changeover between heating and cooling | AC208-230V Dead: cooling cycle Live: heating cycle | Continuity check with a tester |
| | 21S4b | P350 - P450 models only | 1) Changeover between heating and cooling 2) Controls outdoor unit heat exchanger capacity | AC208-230V Dead: cooling cycle Outdoor unit heat exchanger capacity at 100% Live: heating cycle Outdoor unit heat exchanger capacity at 50% or heating cycle | |

2. Indoor Unit

| Part Name | Symbol (functions) | Notes | Usage | Specification | Check method |
|------------------------|---|-------|--|---|--|
| Linear expansion valve | LEV | | 1) Adjusts superheat at the indoor heat exchanger outlet during cooling 2) Adjusts subcool at the heat exchanger outlet of the indoor unit during cooling | DC12V Opening of stepping motor driving valve 0-(1400) pulses | Refer to the section "Continuity Test with a Tester". Continuity between white, red, and orange. Continuity between yellow, brown, and blue.  |
| Thermistor | TH1 (Suction air temperature) | | Indoor unit control (Thermo) | $R_0=15k\Omega$ $R_{0/80}=3460$ $R_t = 15 \exp\left\{3460\left(\frac{1}{273+t} - \frac{1}{273}\right)\right\}$ 0°C [32°F]:15kohm 10°C [50°F]:9.7kohm 20°C [68°F]:6.4kohm 25°C [77°F]:5.3kohm 30°C [86°F]:4.3kohm 40°C [104°F]:3.1kohm | Resistance check |
| | TH2 (Pipe temperature) | | 1) Indoor unit control (Frost prevention, Hot adjust) 2) LEV control during heating operation (subcool detection). | | |
| | TH3 (Gas pipe temperature) | | LEV control during cooling operation (superheat detection) | | |
| | TH4 Outdoor air temperature) | | Indoor unit control (Thermo) | | |
| | Temperature sensor (Indoor air temperature) | | Indoor unit control (Thermo) | | |

VII Control

| | |
|---|-----|
| [1] Functions and Factory Settings of the Dipswitches | 81 |
| [2] Controlling the Outdoor Unit | 87 |
| [3] Operation Flow Chart..... | 100 |



[1] Functions and Factory Settings of the Dipswitches

1. Outdoor unit

(1) Control board

| Switch | | Function | Function according to switch setting | | Switch setting timing | | Units that require switch setting Note.2 | |
|--------|------|---|---|---|---|---|--|----|
| | | | OFF | ON | OFF | ON | OC | OS |
| SWU | 1-2 | Unit address setting | Set to 00 or 51-100 with the dial switch | | Before power on | | C | C |
| SW1 | 1-10 | For self-diagnosis/operation monitoring | Refer to the LED monitor display on the outdoor unit board. | | Anytime after power on | | C | C |
| SW2 | 1 | Centralized control switch | Without connection to the centralized controller | With connection to the centralized controller | Before power on | | B | B |
| | 2 | Deletion of connection information | Normal control | Deletion | Before power on | | A | - |
| | 3 | Deletion of error history SW | (OC) Storage of IC/OC error history | (OC) Deletion of IC/OC error history | Anytime after power on (When switched from OFF to ON) | | C | C |
| | | | (OS) Storage of OS error history | (OS) Deletion of OS error history | | | | |
| | 4 | Pump down mode | Normal control | Pump down mode | After being energized and while the compressor is stopped | | A | - |
| | 5 | - | - | - | - | | - | - |
| | 6 | - | - | - | - | | - | - |
| | 7 | Forced defrost (Note 3) | Normal control | Forced defrost starts | 10 minutes after compressor startup | Anytime after power on (When switched from OFF to ON) | A | A |
| | 8 | Defrost timer setting (Note 3) | 50 minutes | 90 minutes | Anytime after power on (When switched from OFF to ON) | | B | B |
| | 9 | - | - | - | - | | - | - |
| 10 | - | - | - | - | | - | - | |

Note

- 1) Unless otherwise specified, leave the switch to OFF where indicated by "-", which may be set to OFF for a reason.
- 2) A: Only the switch on either the OC or OS needs to be set for the setting to be effective on both units.
 B: The switches on both the OC and OS need to be set to the same setting for the setting to be effective.
 C: The setting is effective for the unit on which the setting is made.
- 3) Refer to "VII [2] Controlling the Outdoor Unit" for details.(page 87)

| Switch | Function | Function according to switch setting | | Switch setting timing | | Units that require switch setting Note.2 | | |
|--------|---------------|--|--|---|---|--|----|---|
| | | OFF | ON | OFF | ON | OC | OS | |
| SW3 | 1 | Test run mode: enabled/disabled | SW3-2 disabled | SW3-2 enabled | Anytime after power on | | A | - |
| | 2 | Test run mode: ON/OFF | Stops all ICs | Sends a test-run signal to all IC | After power on and when SW3-1 is on. | | A | - |
| | 3 | Defrost start temperature | P200 - P300 -10°C [14°F] | -5°C [23°F] | Anytime after power on | B | B | |
| | | | P350 - P450 -8°C [18°F] | | | | | |
| | 4 | Defrost end temperature | P200 - P300 10°C [50°F] | 5°C [41°F] | Anytime after power on (except during defrost operation) | B | B | |
| | | | P350 - P450 7°C [45°F] | | | | | |
| | 5 | - | - | - | - | - | - | |
| | 6 | Temperature unit setting | °C | °F (Note 4) | Anytime after power on | | C | C |
| | 7 | - | - | - | - | - | - | |
| | 8 | - | - | - | - | - | - | |
| 9 | Model setting | Outdoor standard static pressure | Outdoor high static pressure | Before being energized | | C | C | |
| 10 | Model setting | High static pressure 60Pa | High static pressure 30Pa | Before being energized | | C | C | |
| SW4 | 1 | - | - | - | - | - | - | |
| | 2 | - | - | - | - | - | - | |
| | 3 | Refrigerant amount adjustment | Normal operation mode | Refrigerant amount adjust mode | Anytime after being energized (except during initial startup mode. Automatically cancelled 60 minutes after compressor startup) | | A | - |
| | 4 | Low-noise mode/step demand switching | Low-noise mode (Note 3) | Step demand mode | Before being energized | | C | C |
| | 5 | - | - | - | - | - | - | |
| | 6 | Cumulative compressor operation time data deletion | Cumulative compressor operation time data is retained. | Cumulative compressor operation time data is deleted. | Anytime after power on (when the unit is turned on) | | C | C |
| | 7 | - | - | - | - | - | - | |
| | 8 | - | - | - | - | - | - | |
| | 9 | - | - | - | - | - | - | |
| | 10 | - | - | - | - | - | - | |

Note

- 1) Unless otherwise specified, leave the switch to OFF where indicated by "-", which may be set to OFF for a reason.
- 2) A: Only the switch on either the OC or OS needs to be set for the setting to be effective on both units.
B: The switches on both the OC and OS need to be set to the same setting for the setting to be effective.
C: The setting is effective for the unit on which the setting is made.
- 3) The noise level is reduced by controlling the compressor frequency and outdoor fan rotation speed. Setting of CN3D is required.(page 24)
- 4) Set SW3-6 to OFF (°C setting) after servicing.

| Switch | Function | Function according to switch setting | | Switch setting timing | | Units that require switch setting Note.2 | | |
|--------|----------|--------------------------------------|---------------------------------|-----------------------|------------------------|--|----|---|
| | | OFF | ON | OFF | ON | OC | OS | |
| SW5 | 1 | Model selection | See the table below (Note 4) | | Before being energized | | C | C |
| | 2 | | | | | | | |
| | 3 | | | | | | | |
| | 4 | | | | | | | |
| | 5 | Low-noise mode selection | Capacity priority mode (Note 3) | Low-noise mode | Before being energized | | A | - |
| | 6 | - | - | - | - | | - | - |
| | 7 | Model selection | See the table below (Note 4) | | Before being energized | | B | B |
| | 8 | - | - | - | - | | - | - |
| | 9 | - | - | - | - | | - | - |
| | 10 | - | - | - | - | | - | - |

Note

- 1) Unless otherwise specified, leave the switch to OFF where indicated by "-", which may be set to OFF for a reason.
- 2) A: Only the switch on either the OC or OS needs to be set for the setting to be effective on both units.
 B: The switches on both the OC and OS need to be set to the same setting for the setting to be effective.
 C: The setting is effective for the unit on which the setting is made.
- 3) When set to the capacity priority mode and if the following conditions are met, the Low-noise mode will terminate, and the unit will go back into the normal operation mode.
 Cooling: Outside temperature is high or high pressure is high.
 Heating: Outside temperature is low or low pressure is low.(page 22)
- 4) The table below summarizes the factory settings for dipswitches SW5-1 through SW5-4, and SW5-7. The factory setting for all other dipswitches is OFF.

| SW 5 | | | | | model |
|------|-----|-----|-----|----|---------------|
| 1 | 2 | 3 | 4 | 7 | |
| OFF | ON | OFF | OFF | ON | P200YHA model |
| ON | ON | OFF | OFF | ON | P250YHA model |
| OFF | OFF | ON | OFF | ON | P300YHA model |
| OFF | ON | ON | OFF | ON | P350YHA model |
| ON | ON | ON | OFF | ON | P400YHA model |
| OFF | OFF | OFF | ON | ON | P450YHA model |

(2) INV board

Functions are switched with the following connector.

| Connector | Function | Function according to connector | | Setting timing | |
|-----------------------------|---|---------------------------------|--|------------------------|----------|
| | | Enabled | Disabled | Enabled | Disabled |
| CN6 short-circuit connector | Enabling/disabling the following error detection functions; ACCT sensor failure (5301 Detail No. 115) ACCT sensor circuit failure (5301 Detail No.117) IPM open/ACCT erroneous wiring (5301 Detail No. 119) Detection of ACCT erroneous wiring (5301 Detail No.120) | Error detection enabled | Error detection disable (No load operation is possible.) | Anytime after power on | |

Note

- CN6 short-circuit connector is mated with the mating connector.
- Leave the short-circuit connector on the mating connector during normal operation to enable error detection and protect the equipment from damage.

2. Function of the switch (Indoor unit)

(1) Dipswitches

1) SW1,3

| Switch | Function | Function according to switch setting | | Switch setting timing | | Notes |
|--------|-----------------------------------|---|--------------------------------|--|---|--|
| | | OFF | ON | OFF | ON | |
| SW1 | 1 | Room temperature detection position | Indoor unit inlet | Built-in sensor on the remote controller | While the unit is stopped (Remote controller OFF) | Set to ON (built-in sensor on the remote controller) on All Fresh (PEFY-VMH-F) model units |
| | 2 | Clogged filter detection | Not available | Available | | |
| | 3 | Filter check reminder time setting | 100h | 2500h | | |
| | 4 | Outside air intake | Disabled | Enabled | | Always set to OFF on PKFY-VBM model units |
| | 5 | Remote display option | Fan output | Thermo-ON signal | | |
| | 6 | Humidifier control | During heating operation | Always on while in the heating mode | | |
| | 7 | Fan speed setting for Heating Thermo-OFF | Very Low | Low | | |
| | | Forced heating operation at OA temp of 5°C or below | Not available | Available | | Applicable to All Fresh model units (PEFY-VMH-F) only |
| | 8 | Fan speed setting for Heating Thermo-OFF | According to the SW1-7 setting | Preset speed | | |
| | | - | - | - | | Applicable to All Fresh model units (PEFY-VMH-F) only |
| 9 | Self-recovery after power failure | Disabled | Enabled | | | |
| 10 | Power source start-stop | Disabled | Enabled | | | |
| SW3 | 1 | Unit model selection | Heat pump | Cooling only | | |
| | 2 | Louver | Not available | Available | | |
| | 3 | Vane | Not available | Available | | |
| | 4 | Vane swing function | Not available | Available | Always set to OFF on PKFY-VBM model units | |
| | 5 | - | - | - | | |
| | 6 | Vane angle limit setting for cooling operation | Downblow B,C | Horizontal | Always set to Downblow B or C on PKFY-VBM model units | |
| | | Initial vane position | Enabled | Disabled | PLFY-VLMD model only | |
| | 7 | Automatic LEV value conversion function | Not available | Available | | |
| | 8 | Heating 4°C [7.2°F] up | Enabled | Disabled | Set to ON on floor-standing (PFFY) type units | |
| | 9 | SHm setting | 2°C [3.6°F] | 5°C [9°F] | The setting depends on the model and type. | |
| 10 | SCm setting | 10°C [18°F] | 15°C [27°F] | The setting depends on the model and type. | | |

Note 1. Settings in the shaded areas are factory settings. (Refer to the table below for the factory setting of the switches whose factory settings are not indicated by the shaded cells.)
 Note 2. If both SW1-7 and SW1-8 are set to ON, the fan remains stopped during heating Thermo-OFF.

To prevent incorrect temperature detection due to a build-up of warm air around the indoor unit, use the built-in temperature sensor on the remote controller (SW1-1) instead of the one on the indoor unit inlet thermistor.

Note 3. By setting SW3-1, SW1-7, and SW1-8 to a certain configuration, the fan can be set to remain stopped during cooling Thermo-OFF. See the table below for details.

| Switch setting | Fan speed during Thermo-OFF | | Cooling-only/heat pump | |
|----------------|-----------------------------|---------|------------------------|--------------|
| | Heating | Cooling | | |
| OFF | SW1-7 | SW1-8 | Heat pump | |
| | OFF | OFF | | Very Low |
| | ON | OFF | | Low |
| | OFF | ON | | Preset speed |
| ON | SW1-7 | SW1-8 | Cooling-only | |
| | OFF | OFF | | - |
| | ON | OFF | | - |
| | OFF | ON | | Stop |
| ON | SW1-7 | SW1-8 | Heat pump | |
| | ON | ON | Stop | |

2) SW2

| Model | P20 | P25 | P32 | P40 | P50 | P63 | P71 | P80 | P100 | P125 | P140 | P200 | P250 |
|-----------------------|---------------|---------------|---------------|---------------|---------------|---------------|---------------|---------------|---------------|---------------|---------------|---------------|---------------|
| Capacity (model) code | 4 | 5 | 6 | 8 | 10 | 13 | 14 | 16 | 20 | 25 | 28 | 40 | 50 |
| SW2 setting | ON OFF 123456 | ON OFF 123456 | ON OFF 123456 | ON OFF 123456 | ON OFF 123456 | ON OFF 123456 | ON OFF 123456 | ON OFF 123456 | ON OFF 123456 | ON OFF 123456 | ON OFF 123456 | ON OFF 123456 | ON OFF 123456 |

Note. The setting timing for SW2 is before power is turned on.

(2) Address switch

Actual indoor unit address setting varies in different systems. Refer to the installation manual for the outdoor unit for details on how to make the address setting.

Each address is set with a combination of the settings for the 10's digit and 1's digit.

(Example)

When setting the address to "3", set the 1's digit to 3, and the 10's digit to 0.

When setting the address to "25", set the 1's digit to 5, and the 10's digit to 2.

3. Function of the switch <Remote controller>

(1) MA remote controller (PAR-20MAA)

The SW is located at the bottom of the remote controller under the cover. Operate the switches to perform the remote controller main/sub setting or other function settings. Normally, do not change the settings of switches other than the SW1 (main/sub switching switch). (All the switches are set to "ON" at factory setting.)

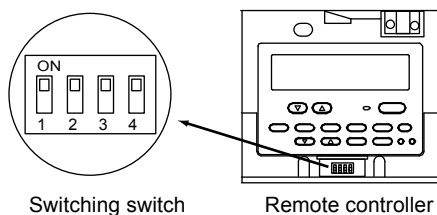

| Switch | Function | ON | OFF | Operation by switch settings | Switch setting timing |
|--------|---|----------------|--------------------|---|-----------------------|
| 1 | Remote controller main/sub setting | Main | Sub | When two remote controllers are connected to one group, set either of the remote controllers to "Sub". | Before power on |
| 2 | At power on of the remote controller | Normal startup | Timer mode startup | When the program timer (only few stock products are available) is connected, set to "Timer mode startup" to resume the operation with timer mode after power is restored. | Before power on |
| 3 | Cooling/heating display set by automatic setting | Displayed | Not displayed | When the automatic mode is set and the "Cooling"/"Heating" display is not necessary, set to "Not displayed". | Before power on |
| 4 | Suction temperature display (discharge temperature display) | Displayed | Not displayed | When the suction temperature (discharge temperature) display is not necessary, set to "Not displayed". | Before power on |

Note

The MA remote controller (PAR-21MAA) does not have the switches listed above. Refer to the installation manual for the function setting.

(2) ME remote controller (PAR-F27MEA)

Set the address of the remote controller with the rotary switch.

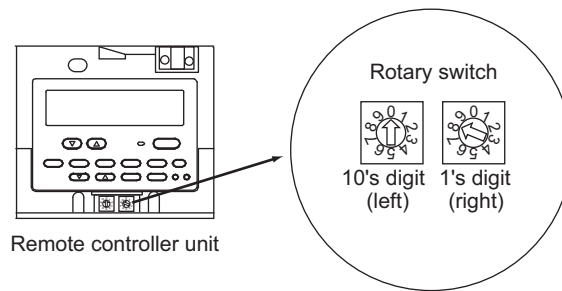

Example: In case of address 108

| | Address setting range | Setting method |
|--------------------------|---|--|
| Main remote controller | 101-150 | Add 100 to the smallest address of all the indoor units in the same group. |
| Sub remote controller | 151-200 | Add 150 to the smallest address of all the indoor units in the same group. |
| Setting of rotary switch | Address No. | |
| 01-99 ^{*1} | 101-199 with the 100's digit automatically being set to 1 ^{*2} | |
| 00 | 200 | |

*1. At factory shipment, the rotary switch is set to 01.

*2. The address range that can be set with the ME remote controller is between 101 and 200. When the dials are set to a number between 01 and 99, the 100's digit is automatically set to [1]. When the dials are set to 00, the 100's digit is automatically set to [2].

Note

To set addresses, use a precision slotted screw driver [2.0 mm [0.08 in] (w)], and do not apply than 19.6N. The use of any other tool or applying too much load may damage the switch.

[2] Controlling the Outdoor Unit

-1- Outline of Control Method

- The outdoor units are designated as OC, OS1 and OS2 in the order of capacity from large to small (if two or more units have the same capacity, in the order of address from small to large).
- The setting of outdoor unit can be verified by using the self-diagnosis switch (SW1).

| SW1 | | Display | | | | | | | | | | | | | | | | | | | | | | | | | | | | | | |
|-----|--|---------|---|---|---|---|---|---|----|---|----|---|---|---|---|---|---|---|---|---|---|---|---|---|---|---|---|---|---|---|---|---|
| ON | <table border="1"> <tr> <td>1</td><td>2</td><td>3</td><td>4</td><td>5</td><td>6</td><td>7</td><td>8</td><td>9</td><td>10</td> </tr> <tr> <td>■</td><td>■</td><td>■</td><td>■</td><td>□</td><td>□</td><td>□</td><td>□</td><td>□</td><td>□</td> </tr> <tr> <td>□</td><td>□</td><td>□</td><td>□</td><td>■</td><td>■</td><td>■</td><td>■</td><td>■</td><td>■</td> </tr> </table> | 1 | 2 | 3 | 4 | 5 | 6 | 7 | 8 | 9 | 10 | ■ | ■ | ■ | ■ | □ | □ | □ | □ | □ | □ | □ | □ | □ | □ | ■ | ■ | ■ | ■ | ■ | ■ | <ul style="list-style-type: none"> ■ The unit is designated as the OC: "oc" appears on the display. ■ The unit is designated as OS1: "oS-1" appears on the display ■ The unit is designated as OS2: "oS-2" appears on the display. |
| 1 | 2 | 3 | 4 | 5 | 6 | 7 | 8 | 9 | 10 | | | | | | | | | | | | | | | | | | | | | | | |
| ■ | ■ | ■ | ■ | □ | □ | □ | □ | □ | □ | | | | | | | | | | | | | | | | | | | | | | | |
| □ | □ | □ | □ | ■ | ■ | ■ | ■ | ■ | ■ | | | | | | | | | | | | | | | | | | | | | | | |

- The OC determines the operation mode and the control mode, and it also communicates with the indoor units.
- The OS exercises autonomous distributed control (over defrost, error detection, and actuator control etc.) according to the operation/control mode signals that are sent from the OC.

-2- Startup sequence rotation

- At the initial startup, outdoor units start up in the order of "OC, OS1 and OS2." After two or more hours of operation, the startup sequence changes to "OS1, OS2 and OC" or "OS2, OC and OS1".
- Startup sequence rotation is performed while all the indoor units are stopped. (Even after two hours of operation, startup sequence rotation is not performed while the compressor is in operation.)
- Refer to [-12- Control at Initial Start-up] for the initial startup.
- Performing startup sequence rotation does not change the basic operation of OC and OS. Only startup sequence is changed.
- Startup sequence of the outdoor units can be checked with the self-diagnosis switch (SW1) on the OC.

| SW1 | | Display | | | | | | | | | | | | | | | | | | | | | | | | | | | | | | |
|-----|--|---------|---|---|---|---|---|---|----|---|----|---|---|---|---|---|---|---|---|---|---|---|---|---|---|---|---|---|---|---|---|--|
| ON | <table border="1"> <tr> <td>1</td><td>2</td><td>3</td><td>4</td><td>5</td><td>6</td><td>7</td><td>8</td><td>9</td><td>10</td> </tr> <tr> <td>■</td><td>■</td><td>■</td><td>■</td><td>□</td><td>■</td><td>■</td><td>■</td><td>■</td><td>■</td> </tr> <tr> <td>■</td><td>■</td><td>■</td><td>■</td><td>■</td><td>■</td><td>■</td><td>■</td><td>■</td><td>■</td> </tr> </table> | 1 | 2 | 3 | 4 | 5 | 6 | 7 | 8 | 9 | 10 | ■ | ■ | ■ | ■ | □ | ■ | ■ | ■ | ■ | ■ | ■ | ■ | ■ | ■ | ■ | ■ | ■ | ■ | ■ | ■ | <ul style="list-style-type: none"> ■ OC→OS1→OS2: "oc" and the OC address appear alternately on the display. ■ OS1→OS2→OC: "oS-1" and the OS1 address appear alternately on the display. ■ OS2→OC→OS1: "oS-2" and the OS2 address appear alternately on the display. |
| 1 | 2 | 3 | 4 | 5 | 6 | 7 | 8 | 9 | 10 | | | | | | | | | | | | | | | | | | | | | | | |
| ■ | ■ | ■ | ■ | □ | ■ | ■ | ■ | ■ | ■ | | | | | | | | | | | | | | | | | | | | | | | |
| ■ | ■ | ■ | ■ | ■ | ■ | ■ | ■ | ■ | ■ | | | | | | | | | | | | | | | | | | | | | | | |

-3- Initial Control

- When the power is turned on, the initial processing of the microcomputer is given top priority.
- During the initial processing, control processing of the operation signal is suspended. (The control processing is resumed after the initial processing is completed. Initial processing involves data processing in the microcomputer and initial setting of each of the LEV opening. This process will take up to 5 minutes.)
- During the initial processing, the LED monitor on the outdoor unit's control board displays S/W version -> refrigerant type -> heat pump -> cooling only and capacity -> and communication address in turn every second.

-4- Control at Start-up

- The upper limit of frequency during the first 3 minutes of the operation is 50 Hz.
- When the power is turned on, normal operation will start after the initial start-up mode (to be described later) has been completed (with a restriction on the frequency).

-5- Bypass Control

Bypass solenoid valves (SV1a), which bypass the high- and low- pressure sides, perform the following functions.

(1) Bypass solenoid valve (SV1a) (ON = Open), (SV9) (ON = Open)

| Operation | SV1a | |
|--|---|--|
| | ON | OFF |
| When starting-up the compressor of each outdoor unit | ON for 4 minutes. | |
| After the restoration of thermo or 3 minutes after restart | ON for 4 minutes. | |
| During cooling or heating operation with the compressor stopped | Always ON. Exception: OFF when 63HS1-63LS is 0.2 MPa [29 psi] or less | |
| After the operation has stopped | ON for 3 minutes. Exception: OFF when 63HS1-63LS is 0.2 MPa [29 psi] or less | |
| During defrost operation | ON | |
| While the compressor is operating at the minimum frequency and when the low pressure (63LS) drops (3 or more minutes after compressor startup) | When low pressure (63LS) drops below 0.23 MPa [33 psi]. | When low pressure (63LS) exceeds 0.38 MPa [55 psi]. |
| When high pressure (63HS1) rises | When 63HS1 exceeds 3.62 MPa [525 psi] | When 63HS1 is or below 3.43 MPa [497 psi] and 30 seconds have passed |

| Operation | SV9 | |
|---|-------------------------------------|---|
| | ON | OFF |
| When high pressure (63HS1) rises during the heating operation | When 63HS1 exceeds 3.50MPa [507psi] | When 63HS1 is or below 2.70Mpa [391psi] |
| When startup or resuming operation after a defrost cycle | ON for 5 minutes and goes OFF | |
| Others | Always OFF | |

-6- Compressor Frequency Control

- Depending on the capacity required, the frequency of the compressor is controlled to keep constant evaporation temperature (0°C [32°F] = 0.71 MPa [103 psi]) during cooling operation, and condensing temperature (49°C [120°F] = 2.88 MPa [418 psi]) during heating operation.
- The table below summarizes the operating frequency ranges of the inverter compressor during normal operation.
- The OS in the multiple-outdoor-unit system operates at the actual compressor frequency value that is calculated by the OS based on the preliminary compressor frequency value that the OC determines.

| Model | Frequency/cooling (Hz) | | Frequency/heating (Hz) | |
|-----------|------------------------|-----|------------------------|-----|
| | Max | Min | Max | Min |
| 200 model | 52 | 13 | 53 | 13 |
| 250 model | 65 | 13 | 71 | 13 |
| 300 model | 74 | 16 | 81 | 16 |
| 350 model | 95 | 16 | 101 | 16 |
| 400 model | 97 | 18 | 102 | 18 |
| 450 model | 111 | 18 | 117 | 18 |

Note

The maximum frequency during heating operation is affected by the outdoor air temperature to a certain extent.

(1) Pressure limit

The upper limit of high pressure (63HS1) is preset, and when it exceeds the upper limit, the frequency is decreased every 15 seconds.

- The actuation pressure is when the high-pressure reading on 63HS1 is 3.58MPa[519psi].

(2) Discharge temperature limit

Discharge temperature (TH4) of the compressor in operation is monitored, and when it exceeds the upper limit, the frequency is decreased every minute.

- Operating temperature is 115°C [239°F].

(3) Periodic frequency control

Frequency control other than the ones performed at start-up, upon status change, and for protection is called periodic frequency control (convergent control) and is performed in the following manner.

Periodic control cycle

Periodic control is performed after the following time has passed

- 30 seconds after either compressor start-up or the completion of defrost operation
- 30 seconds after frequency control based on discharge temperature or pressure limit

The amount of frequency change

The amount of frequency change is controlled to approximate the target value based on the evaporation temperature (Te) and condensing temperature (Tc).

-7- Defrost Operation Control

(1) Starting the defrost operation

- The defrost cycle will start when all of the three conditions (outside temperature, cumulative compressor operation time, and pipe temperature) under <Condition 1>, <Condition 2>, or <Condition 3> are met.

| | Condition 1 | Condition 2 | Condition 3 |
|--------------------------------------|--|--|---|
| Outside temperature (TH7) | -5°C [23°F] or above | -5°C [23°F] or below | |
| Cumulative compressor operation time | 50 minutes or more 90 minutes or more if the defrost prohibit timer is set to 90. | | 250 minutes or more |
| Pipe temperature (TH3) | The pipe temperature has stayed below the temperatures in the table below (Note1) for three minutes. | The pipe temperature has stayed below the value obtained from the formula "Outside temperature (TH7) - 5°C [23°F]" for three minutes, or the 63LS reading has stayed below the value obtained from the formula " $1.5 + 0.02 \times (20 + TH7)$ " for three minutes. | The pipe temperature has stayed below the temperatures in the table below (Note1) for three minutes |

Note

1) Pipe temperature(TH3)

| Model | TH3 | |
|-----------|---------------|--------------|
| | SW3 - 3 OFF | SW3 - 3 ON |
| 200 model | - 10°C [14°F] | - 5°C [23°F] |
| 250 model | - 10°C [14°F] | - 5°C [23°F] |
| 300 model | - 10°C [14°F] | - 5°C [23°F] |
| 350 model | - 8°C [18°F] | - 5°C [23°F] |
| 400 model | - 8°C [18°F] | - 5°C [23°F] |
| 450 model | - 8°C [18°F] | - 5°C [23°F] |

- The defrost cycle will not start if other outdoor units are in the defrost cycle or until a minimum of 10 minutes have passed since the completion of the last defrost cycle.
- If 10 minutes have passed since compressor startup or since the completion of a defrost cycle, a forced defrost cycle can be started by setting DIP SW2-7 to ON.
- Even if the defrost-prohibit timer is set to 90 minutes, the actual defrost-prohibit time for the next defrost cycle is 50 minutes if the last defrost cycle took 12 minutes.
- All units in the heating mode will simultaneously go into the defrost cycle in a system with multiple units. The units that are not in operation may or may not go into the defrost cycle, depending on the cumulative operation time of their compressors.

(2) Defrost operation

| | | |
|----------------------|-----------------------|----------------------|
| Compressor frequency | Model | Compressor frequency |
| | 200 model | 60 Hz |
| | 250 model | 65 Hz |
| | 300 model | 65 Hz |
| | 350 model | 103 Hz |
| | 400 model | 103 Hz |
| | 450 model | 103 Hz |
| Outdoor unit fan | Stopped | |
| SV1a | ON | |
| SV5b | OFF (OPEN) | |
| 21S4a | OFF | |
| 21S4b | OFF | |
| SV9 | OFF | |
| LEV1 | 0 pulse ^{*1} | |
| LEV2 | 3000 pulses | |

*1. 300 pulses if either of the following formulas are satisfied: $63LS < 2\text{kgf/cm}^2$ or $TH4 \geq 100^\circ\text{C}$ [212°F].

(3) Stopping the defrost operation

1) When SW3-4 is set to OFF

- The defrost cycle ends when 12 minutes have passed since the beginning of the cycle, or when the pipe temperature (TH3), in the following table, or above has been continuously detected for 4 minutes.
- Defrost operation will not stop its operation for 2 minutes once started unless the piping temperature exceeds 25°C [77°F] within 2 minutes, in which case the operation will stop.
- In the multiple-outdoor-unit system, defrosting is stopped on all units at the same time.

2) When SW3-4 is set to ON

- The defrost cycle ends when 12 minutes have passed since the beginning of the cycle, or when the pipe temperature (TH3) has been continuously detected for 2 minutes (when SW3-4 is set to OFF) that exceeds the values in the table below.
- The defrost cycle will not end for two minutes once started unless the pipe temperature α goes outside the ranges below. ($25^\circ\text{C}[77^\circ\text{F}] \geq \alpha \geq 5^\circ\text{C}[41^\circ\text{F}]$, $\alpha = 25^\circ\text{C}[77^\circ\text{F}] + TH7$)

| Model | TH3 | |
|-----------|-------------|------------|
| | SW3 - 4 OFF | SW3 - 4 ON |
| 200 model | 10°C [50°F] | 5°C [41°F] |
| 250 model | 10°C [50°F] | 5°C [41°F] |
| 300 model | 10°C [50°F] | 5°C [41°F] |
| 350 model | 7°C [45°F] | 5°C [41°F] |
| 400 model | 7°C [45°F] | 5°C [41°F] |
| 450 mode; | 7°C [45°F] | 5°C [41°F] |

(4) Problems during defrost operation

- If a problem is detected during defrost operation, the operation will be stopped, and the defrost prohibition time based on the integrated compressor operation time will be set to 20 minutes.

(5) Change in the number of operating indoor units during defrost operation

- Even when there is a change in the number of operating indoor units during defrost operation, the operation will continue, and an adjustment will be made after the completion of the defrost operation.
- Defrost operation will be continued, even if the indoor units stop or under the Thermo-OFF conditions until it has run its course.

-8- Refrigerant Recovery Control

Recovery of refrigerant is performed during heating operation to prevent the refrigerant from accumulating inside the unit while it is stopped (unit in fan mode), or inside the indoor unit that is in cooling mode or in heating mode with thermo off. It is also performed during cooling operation to prevent an excessive amount of refrigerant from accumulating in the outdoor heat exchanger.

It is also performed during cooling operation to prevent an excessive amount of refrigerant from accumulating in the outdoor heat exchanger.

(1) During heating operation

Starting refrigerant recovery mode

The refrigerant recovery mode in heating starts when all of the following three conditions are met:

- 15 minutes have passed since the completion of previous refrigerant recovery.
- TH4 > 115°C [239°F]
- Frequencies below 50 Hz

Refrigerant recovery

- 1) Refrigerant is recovered with the LEV on the applicable indoor unit (unit under stopping mode, fan mode, cooling, heating with thermo off) being opened for 30 seconds.

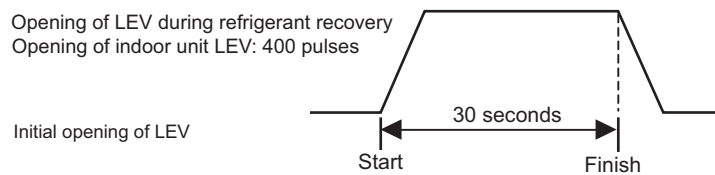

- 2) Periodic capacity control of the outdoor units and periodic LEV control of the indoor units will be suspended during refrigerant recovery operation; they will be performed after the recovery has been completed.

(2) During cooling operation

Starting refrigerant recovery mode

The refrigerant recovery mode starts when all the following conditions are met:

- 30 minutes have passed since the completion of previous refrigerant recovery.
- When the unit keeps running for 3 minutes in a row or more with high discharge temperature
- TH4 > 105°C [221°F] or 63HS1 > 3.43 MPa [497 psi] (35 kg/cm²G) and SC0 > 10°C [18°F]

Refrigerant recovery

The opening of LEV1 is increased and periodic control begins again.

-9- Capacity Control of Outdoor Fan

(1) Control method

- Depending on the capacity required, the rotation speed of the outdoor unit fan is controlled by the inverter, targeting a constant evaporation temperature of (0°C [32°F]= 0.71 MPa [103 psi]) during cooling operation and constant condensing temperature of (49°C [120°F]= 2.88 MPa [418 psi]) during heating operation.
- The OS in the multiple-outdoor-unit system operates at the actual outdoor unit fan control value that is calculated by the OS based on the preliminary outdoor unit fan control value that the OC determines.

(2) Control

- Outdoor unit fan stops while the compressor is stopped (except in the presence of input from snow sensor).
- The fan operates at full speed for 5 seconds after start-up. (Only when TH7 < 0°C [32°F])
- The outdoor unit fan stops during defrost operation.

-10- Subcool Coil Control (Linear Expansion Valve <LEV1>)

- The OC, OS1, and OS2 controls the subcool coil individually.
- The LEV is controlled every 30 seconds to maintain constant the subcool at the outdoor unit heat exchanger outlet that is calculated from the values of high pressure (63HS1) and liquid piping temperature (TH3), or the superheat that is calculated from the values of low pressure (63LS) and the bypass outlet temperature (TH2) of the subcool coil.
- LEV opening is controlled based on the values of the inlet (TH6) and the outlet (TH3) temperatures of the subcool coil, high pressure (63HS1), and discharge temperature (TH4). In a single-outdoor-unit system, the LEV is closed (0) in the heating mode, while the compressor is stopped, and during cooling Thermo-OFF. In a multiple-outdoor-unit system, the LEV closes (0) during heating operation, while the compressor is stopped, or during cooling Thermo-OFF. The LEV opens to a specified position when 15 minutes have passed after Thermo-OFF. (65 pulses)
- LEV1 outputs 0 pulse during the defrost cycle, and 300 pulses if either of the following formulas are satisfied: $63LS < 2\text{kgf/cm}^2$ or $TH4 \geq 100^\circ\text{C}$ [212°F].

-11- Refrigerant flow control (Linear expansion valve <LEV2>)

- Refrigerant flow is controlled by each unit in the combined models during heating. Refrigerant flow control is performed by the OC, OS1, and OS2 individually. The valve opens to a specified angle during cooling (Opening: 2100 pulses)
- Valve opening is controlled based on the values of high pressure (63HS1), discharge temperature (TH4), low pressure(63LS), and piping temperature (TH5).
- The valve moves to the predetermined position while the unit is stopped.
- The valve remains open at the preset position. (3000 pulses)

-12- Control at Initial Start-up

- When started up for the first time before 12 hours have elapsed after power on, the unit goes into the initial startup mode.
- At the completion of the initial operation mode on the OC, OS1, and OS2, they will go into the normal control mode.

1. Flowchart of initial operation

(1) P200,P250, P300, P350, P400, P450 models

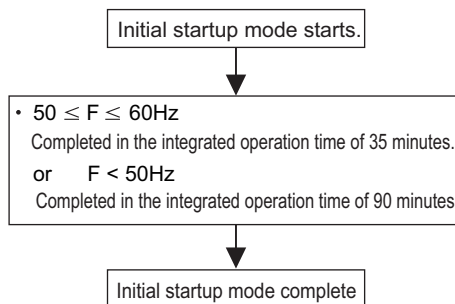

(2) P500, P550, P600, P650, P700, P750, P800, P850, P900 models

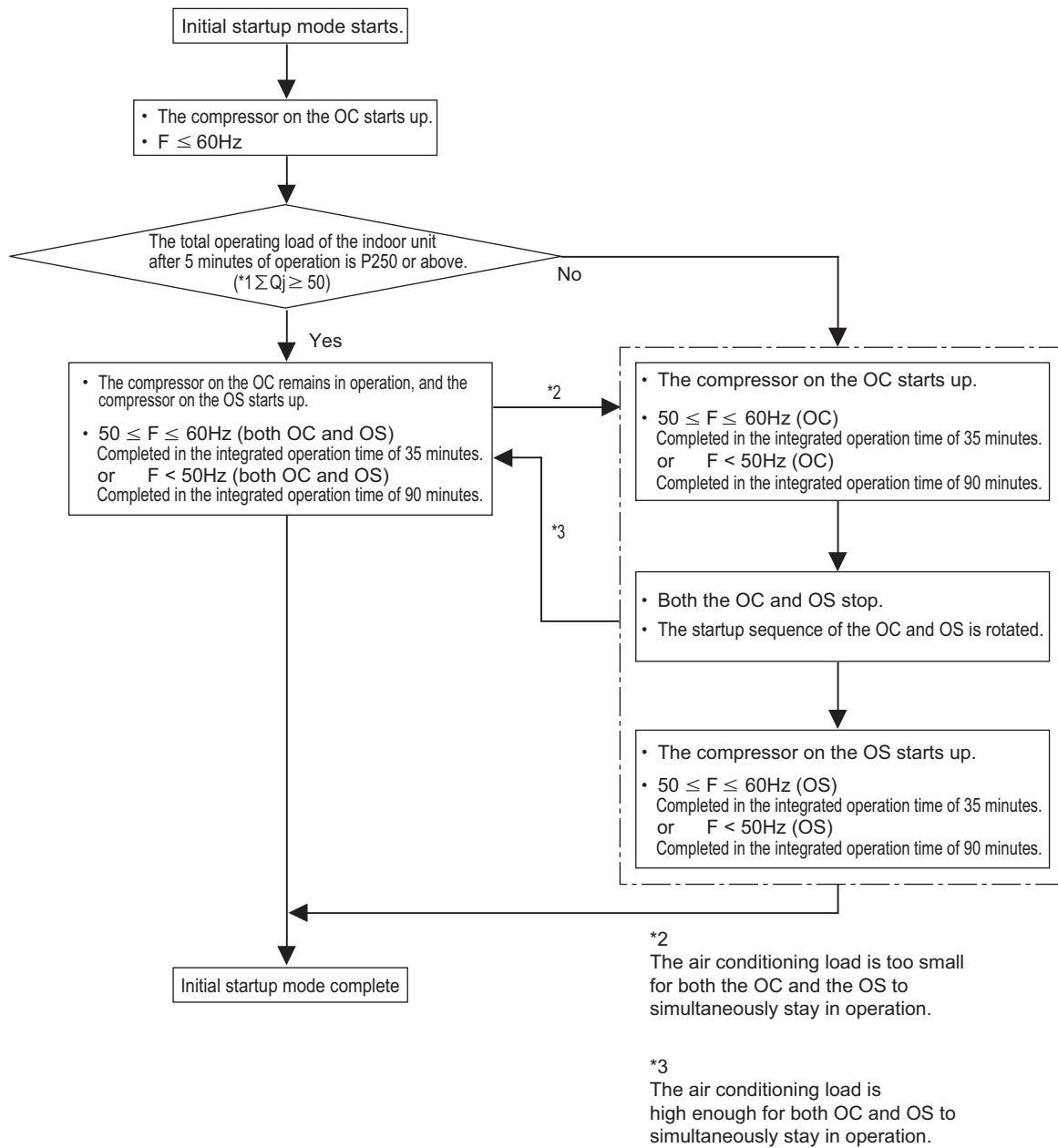

*1 $\sum Q_j$: Total capacity (model name) code
Refer to VII [1] 2.(1) Dipswitches for the capacity codes (page 84).

(3) P950, P1000, P1050, P1100, P1150, P1200, P1250 models

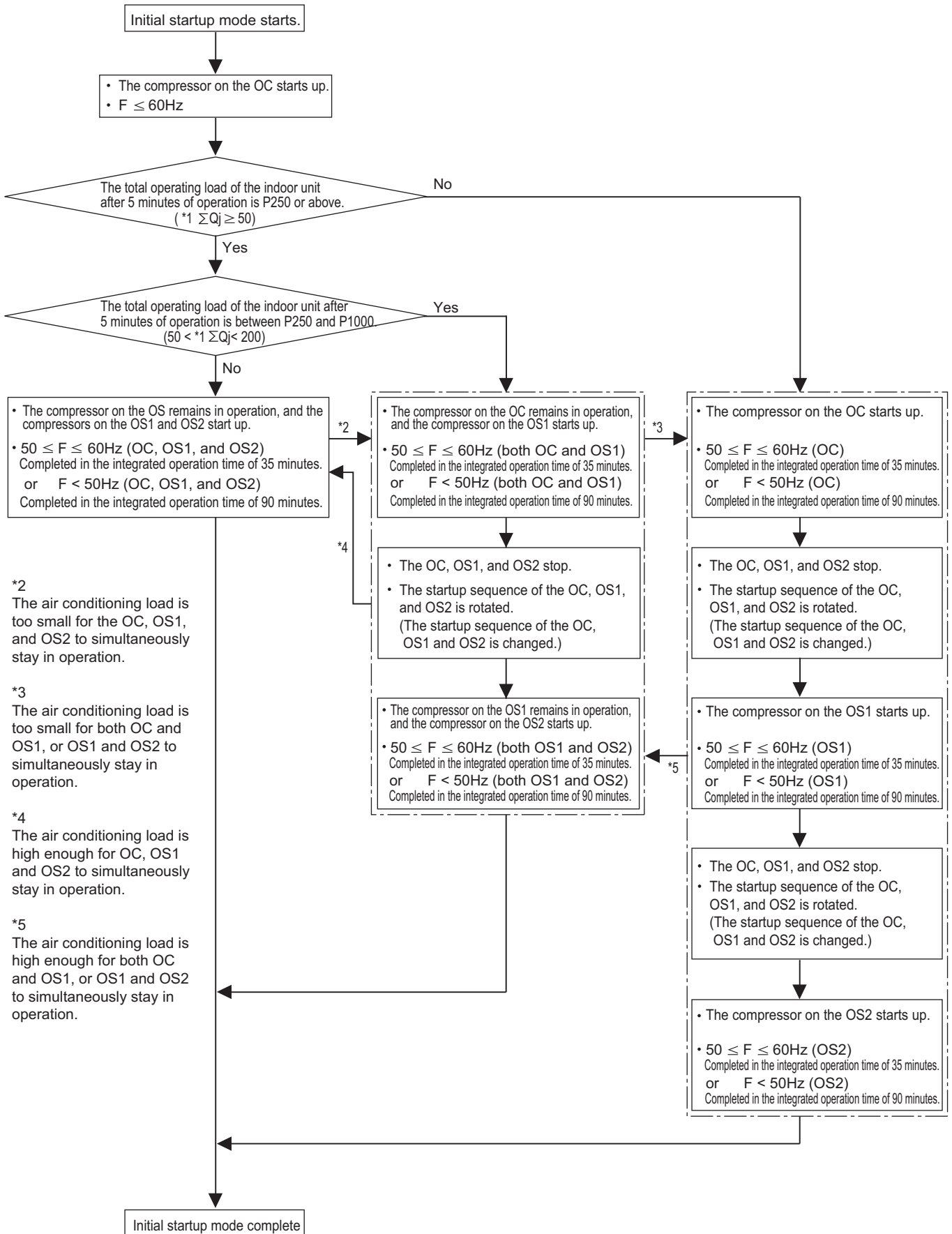

*2
The air conditioning load is too small for the OC, OS1, and OS2 to simultaneously stay in operation.

*3
The air conditioning load is too small for both OC and OS1, or OS1 and OS2 to simultaneously stay in operation.

*4
The air conditioning load is high enough for OC, OS1 and OS2 to simultaneously stay in operation.

*5
The air conditioning load is high enough for both OC and OS1, or OS1 and OS2 to simultaneously stay in operation.

*1 ΣQj: Total capacity (model name) code
Refer to VII [1] 2.(1) Dipswitches for the capacity codes (page 84).

-13- Emergency Operation Mode

1. Problems with the outdoor unit

- The P500 through P900 models have an emergency operation mode that allows the outdoor unit to perform a backup operation when one of the outdoor units in the system malfunctions. The P950 through P1250 models have the same mode that works when one or two of the outdoor units in the system malfunctions.
- This mode can be started by performing an error reset via the remote controller.

(1) Starting the emergency operation

- 1) When an error occurs, the error source and the error code will be displayed on the display on the remote controller.
- 2) The error is reset using the remote controller.
- 3) If an error code appears that permits an emergency operation in step 1) above, (See the table below.), the retry operation starts.
- 4) If the same error is detected during the retry operation (step 3 above), an emergency operation can be started by resetting the error via the remote controller.

Error codes that permit an emergency operation (Applicable to both OC and OS)

| Trouble source | | Error codes that permit an emergency operation | Error code description |
|-------------------------------------|------|--|---|
| Compressor Fan motor Inverter | | 0403 | Serial communication error |
| | | 4220, 4225 | Bus voltage drop |
| | | 4230 | Heatsink overheat protection |
| | | 4240 | Overload protection |
| | | 4250, 4255 | Overcurrent relay trip |
| | | 5110 | Heatsink temperature sensor failure (THHS) |
| | 5301 | Current sensor/circuit failure | |
| Thermistor | TH2 | 5102 | Subcool heat exchanger bypass outlet temperature sensor failure |
| | TH3 | 5103 | Pipe temperature sensor failure |
| | TH4 | 5104 | Discharge temperature sensor failure |
| | TH5 | 5105 | Accumulator inlet temperature sensor failure |
| | TH6 | 5106 | Subcool heat exchanger liquid outlet sensor failure |
| | TH7 | 5107 | Outside air temperature sensor failure |
| Power | | 4102 | Open phase |
| | | 4115 | Power supply sync signal abnormality |

Emergency operation pattern (2 outdoor units)

| | | OC failure pattern | OS failure pattern |
|---|---------|--------------------|--------------------|
| OC | | Trouble | Normal |
| OS | | Normal | Trouble |
| Emergency operation | Cooling | Permitted | Permitted |
| | Heating | Permitted | Permitted |
| Maximum total capacity of indoor units (Note 1) | | 60% | |

Emergency operation pattern (3 outdoor units)

| | | OC failure pattern | OS1 failure pattern | OS2 failure pattern | OC, OS1 failure pattern | OC, OS2 failure pattern | OS1, OS2 failure pattern |
|---|---------|--------------------|---------------------|---------------------|-------------------------|-------------------------|--------------------------|
| OC | | Trouble | Normal | Normal | Trouble | Trouble | Normal |
| OS1 | | Normal | Trouble | Normal | Trouble | Normal | Trouble |
| OS2 | | Normal | Normal | Trouble | Normal | Trouble | Trouble |
| Emergency operation | Cooling | Permitted | Permitted | Permitted | Permitted | Permitted | Permitted |
| | Heating | Permitted | Permitted | Permitted | Permitted | Permitted | Permitted |
| Maximum total capacity of indoor units (Note 1) | | 60% | | | 40% | | |

(Note 1) If an attempt is made to put into operation a group of indoor units whose total capacity exceeds the maximum allowable capacity, some of the indoor units will go into the same condition as Thermo-OFF.

(2) Ending the emergency operation

1) End conditions

- When one of the following conditions is met, emergency operation stops, and the unit makes an error stop.
- When the integrated operation time of compressor in cooling mode has reached four hours.
- When the integrated operation time of compressor in heating mode has reached two hours.
- When an error is detected that does not permit the unit to perform an emergency operation.

2) Control at or after the completion of emergency operation

- At or after the completion of emergency operation, the compressor stops, and the error code reappears on the remote controller.
- If another error reset is performed at the completion of an emergency mode, the unit repeats the procedures in section (1) above.
- To stop the emergency mode and perform a current-carrying operation after correcting the error, perform a power reset.

2. Communication circuit failure or when some of the outdoor units are turned off

This is a temporary operation mode in which the outdoor unit that is not in trouble operates when communication circuit failure occurs or when some of the outdoor units are turned off.

(1) Starting the emergency operation (When the OC is in trouble)

- 1) When an error occurs, the error source and the error code appear on the display on the remote controller.
- 2) Reset the error via the remote controller to start an emergency operation.

Precautions before servicing the unit

- When the OC is in trouble, the OS temporarily takes over the OC's function and performs an emergency operation. When this happens, the indoor unit connection information are changed.
- In a system that has a billing function, a message indicating that the billing system information has an error may appear on the TG-2000A. Even if this message appears, do not change (or set) the refrigerant system information on the TG-2000A. After the completion of an emergency operation, the correct connection information will be restored.

(2) Starting the emergency operation (When the OS is in trouble)

- 1) A communication error occurs. -> An emergency operation starts in approximately six minutes.

Error codes that permit an emergency operation (Applicable to both OC and OS)

| Trouble source | Error codes that permit an emergency operation | Error code description |
|--|--|--------------------------|
| Circuit board failure or the power to the outdoor units is off | 6607 | No acknowledgement error |
| | 6608 | No response error |

Emergency operation pattern (2 outdoor units)

| | | | |
|---|---------|--|--------------------|
| | | OC failure pattern | OS failure pattern |
| OC | | Trouble | Normal |
| OS | | Normal | Trouble |
| Emergency operation | Cooling | Permitted | Permitted |
| | Heating | Permitted | Permitted |
| Maximum total capacity of indoor units (Note 1) | | Capacity that matches the total capacity of the operable outdoor units | |

Emergency operation pattern (3 outdoor units)

| | | | | | | | |
|---|---------|--|---------------------|---------------------|-------------------------|-------------------------|--------------------------|
| | | OC failure pattern | OS1 failure pattern | OS2 failure pattern | OC, OS1 failure pattern | OC, OS2 failure pattern | OS1, OS2 failure pattern |
| OC | | Trouble | Normal | Normal | Trouble | Trouble | Normal |
| OS1 | | Normal | Trouble | Normal | Trouble | Normal | Trouble |
| OS2 | | Normal | Normal | Trouble | Normal | Trouble | Trouble |
| Emergency operation | Cooling | Permitted | Permitted | Permitted | Permitted | Permitted | Permitted |
| | Heating | Permitted | Permitted | Permitted | Permitted | Permitted | Permitted |
| Maximum total capacity of indoor units (Note 1) | | Capacity that matches the total capacity of the operable outdoor units | | | | | |

(Note 1) If an attempt is made to put into operation a group of indoor units whose total capacity exceeds the maximum allowable capacity, some of the indoor units will go into the same condition as Thermo-OFF.

(3) Ending the emergency operation

When communication is restored, the emergency mode is cancelled, and the units go into the normal operation mode.

-14- Operation Mode

(1) Indoor unit operation mode

The operation mode can be selected from the following 5 modes using the remote controller.

| | |
|---|---------------|
| 1 | Cooling mode |
| 2 | Heating mode |
| 3 | Dry mode |
| 4 | Fan mode |
| 5 | Stopping mode |

(2) Outdoor unit operation mode

| | | |
|---|---------------|--|
| 1 | Cooling mode | All indoor units in operation are in cooling mode. |
| 2 | Heating mode | All indoor units in operation are in heating mode. |
| 3 | Stopping mode | All indoor units are in fan mode or stopping mode. |

Note

When the outdoor unit is performing a cooling operation, the operation mode of the connected indoor units that are not in the cooling mode (Stopped, Fan, Thermo-OFF) cannot be changed to heating from the remote controller. If this attempt is made, "Heating" will flash on the remote controller. The opposite is true when the outdoor unit is performing a heating operation. (The first selection has the priority.)

-15- DEMAND Control

Cooling/heating operation can be prohibited (Thermo-OFF) by an external input to the indoor units.

Note

When DIP SW4-4 is set to ON, the 4-step DEMAND control is enabled.

Eight-step demand control is possible in the system with two outdoor units.

Twelve-step demand control is possible in the system with three outdoor units.

Refer to Chapter II -[3]- 2. -(7) "Various types of control using input-output signal connector on the outdoor unit (various connection options)" for details.(page 22)

[3] Operation Flow Chart

1. Mode determination flowchart

(1) Indoor unit (cooling, heating, dry, fan mode)

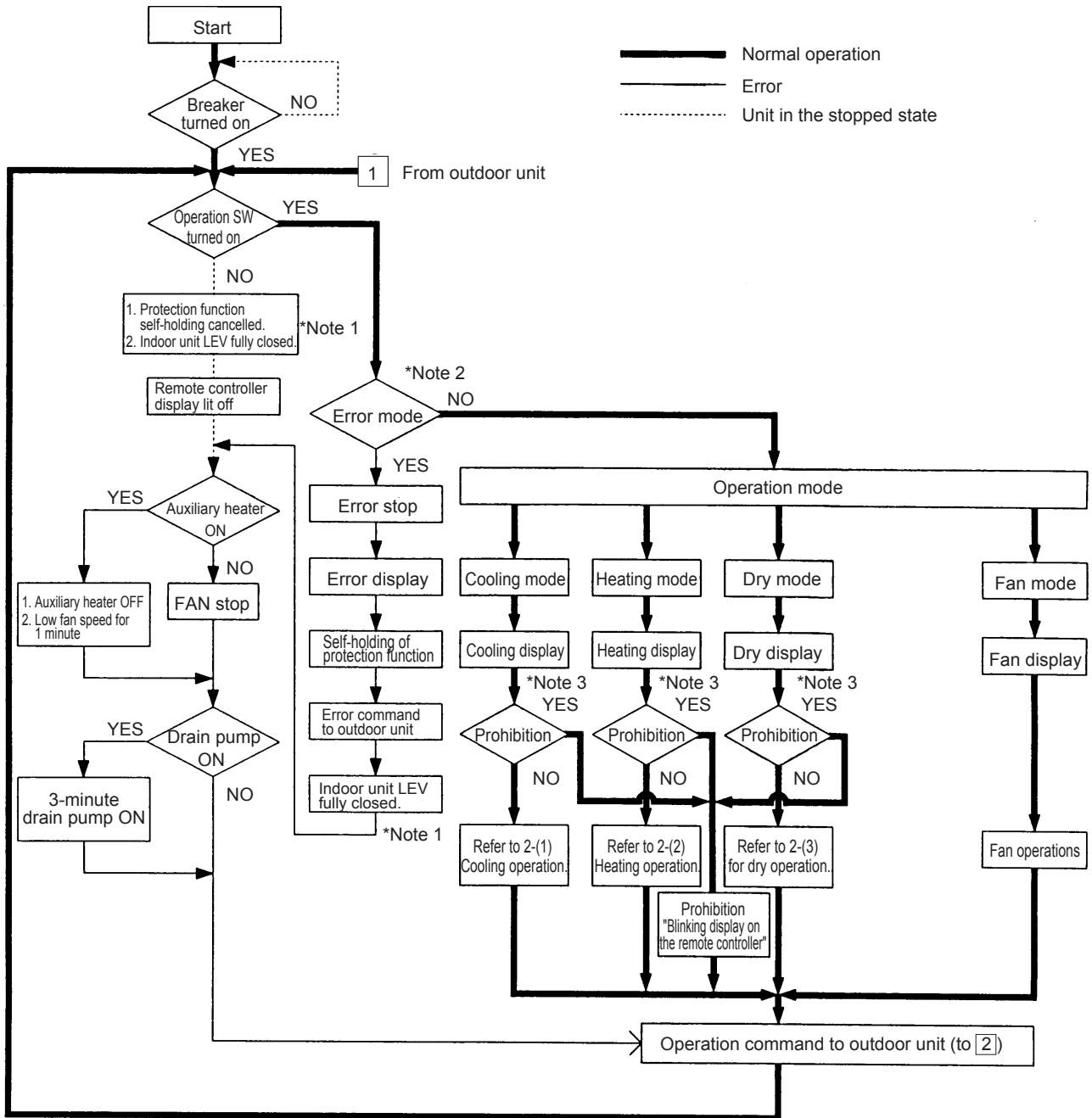

*Note 1. Indoor unit LEV fully closed : Opening 41.

*Note 2. The system may go into the error mode on either the indoor unit or the outdoor unit side. If some of the indoor units are experiencing a problem (except water leakage), only those indoor units that are experiencing the problems will stop. If the outdoor unit is experiencing a problem, all connected indoor units will stop.

*Note 3. The operation will be prohibited when the set cooling/heating mode is different from that of the outdoor unit.

(2) Outdoor unit (cooling and heating modes)

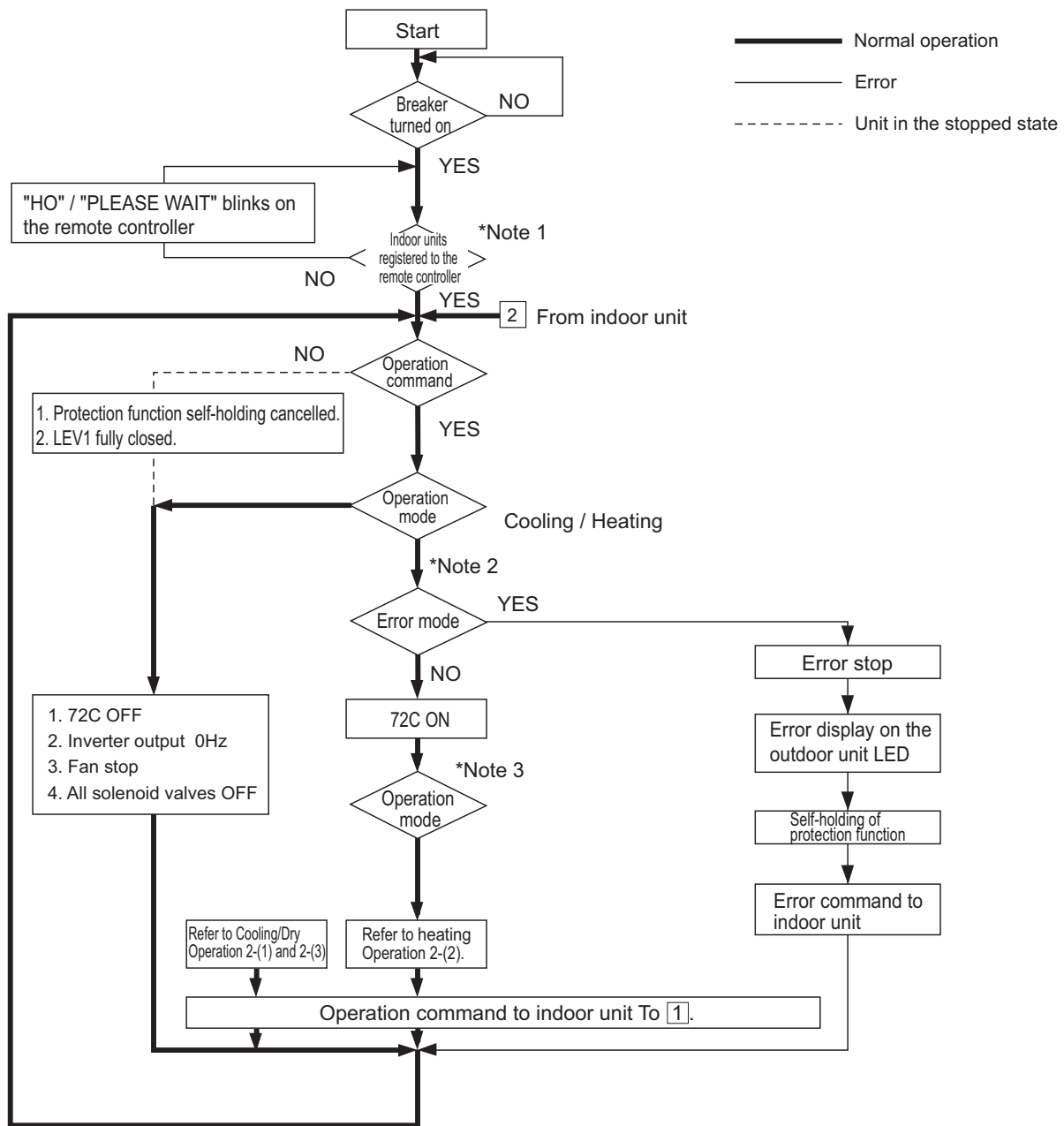

*Note 1. For about 3 minutes after power on, search for the indoor unit address, for the remote controller address, and for the group information will start. During this, "HO" / "PLEASE WAIT" blinks on the display of the remote controller. When the indoor unit to be controlled by the remote controller is missing, "HO" / "PLEASE WAIT" keeps blinking on the display of the remote controller even after 3 or more minutes after power on.

*Note 2. The system may go into the error mode on either the indoor unit or the outdoor unit side. The outdoor stops only when all of the connected indoor units are experiencing problems. The operation of even a single indoor unit will keep the outdoor unit running. The error will be indicated on the LED display.

*Note 3. The outdoor unit operates according to the operation mode commanded by the indoor unit. However, when the outdoor unit is running a cooling operation, come of the operating indoor units will stop, or the operation of these indoor units will be prohibited even when the indoor unit mode is switched from fan mode to heating mode. This also applies when the outdoor unit is running a heating operation.

2. Operations in each mode
(1) Cooling operation

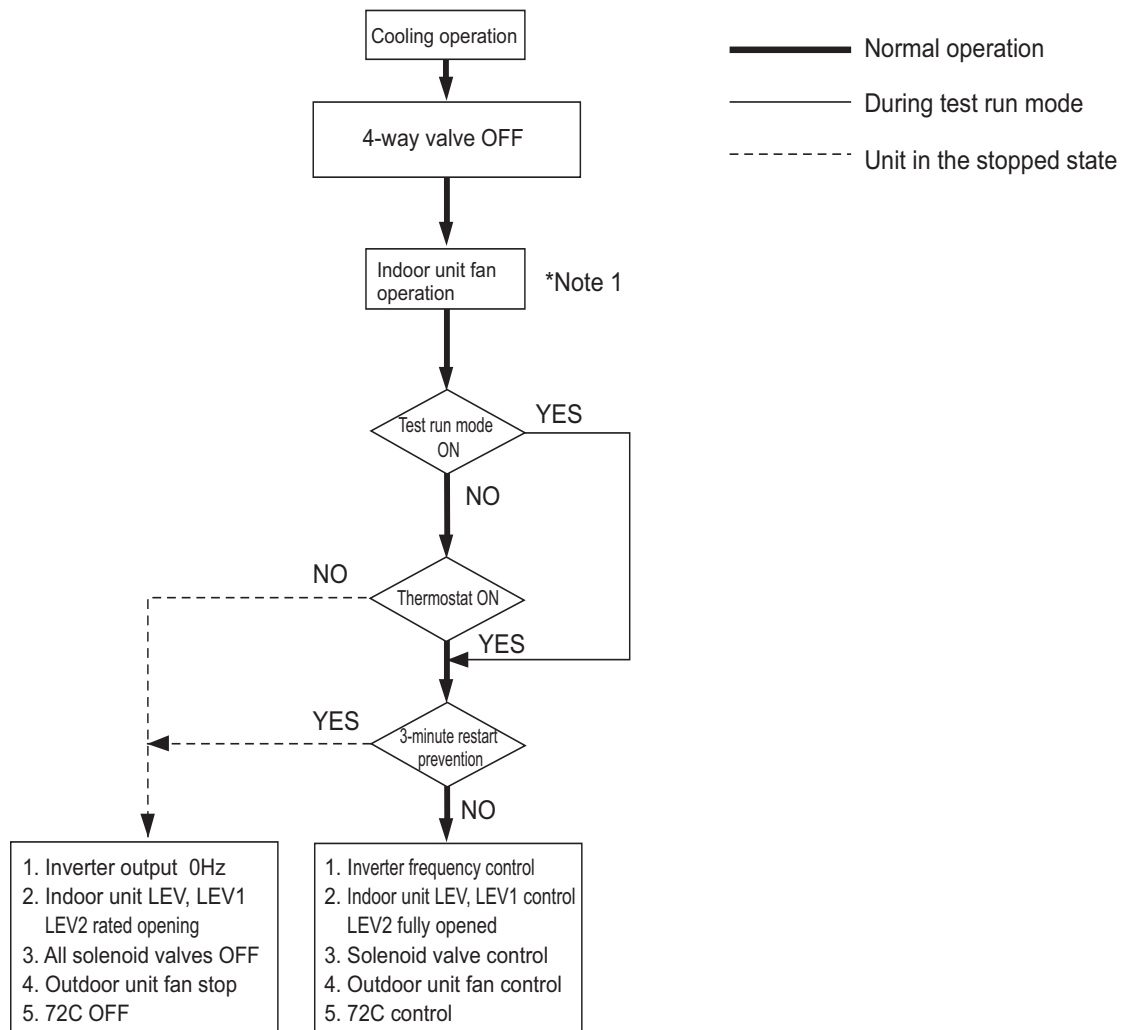

*Note 1. The indoor fan operates at the set notch under cooling mode regardless of the ON/OFF state of the thermostat.

(2) Heating operation

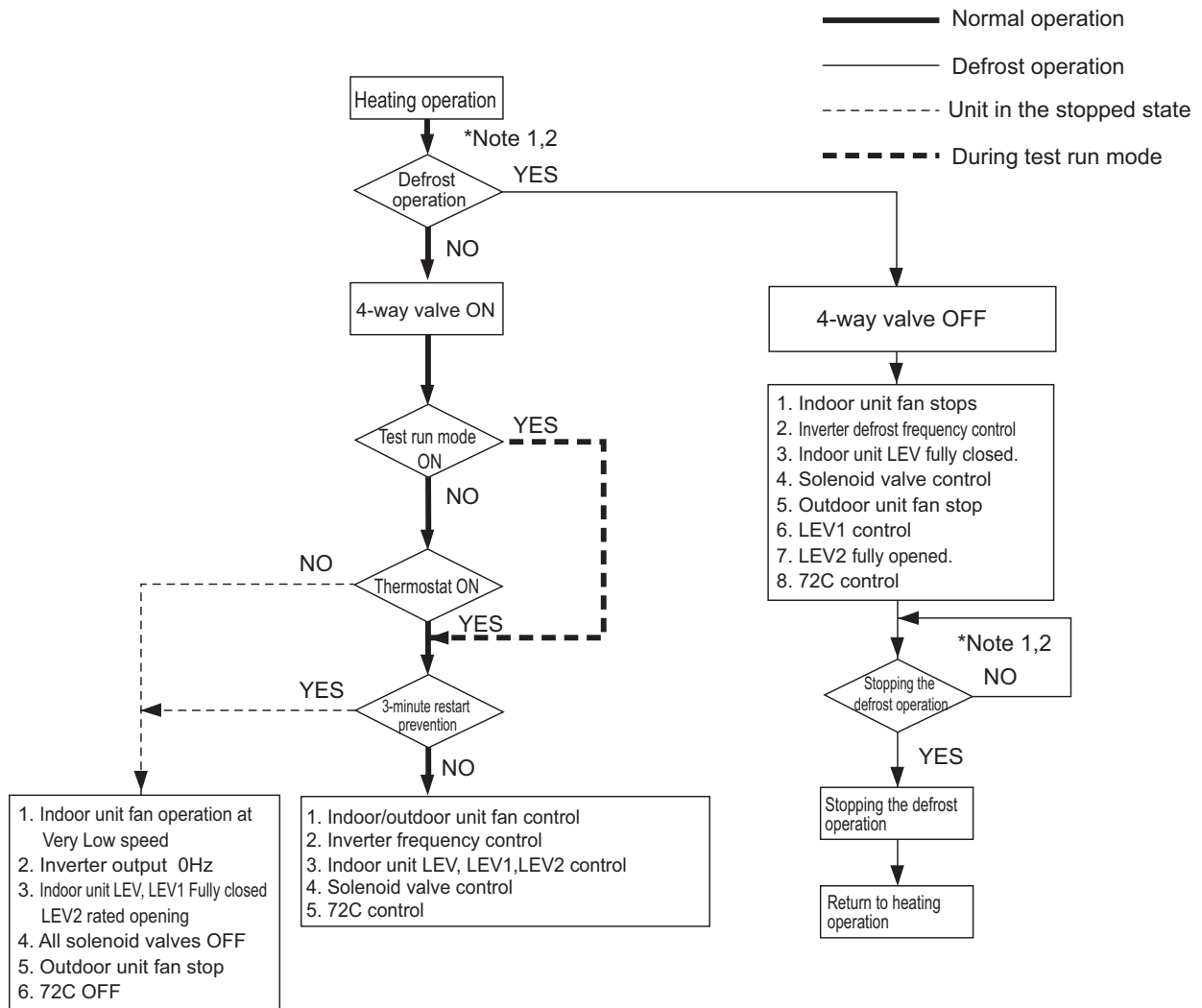

Note

- 1) When outdoor unit starts defrosting, it transmits defrost operations command to indoor unit, and the indoor unit start defrosting operations. Similarly when defrosting operation stops, indoor unit returns to heating operation after receiving defrost end command of outdoor unit.
- 2) Defrost end condition: 12 or more minutes must pass after defrost operation or outdoor unit piping temperature. Refer to "-7- Defrost operation control" of [2] Controlling the Outdoor Unit (page 90) for the temperature.

(3) Dry operation

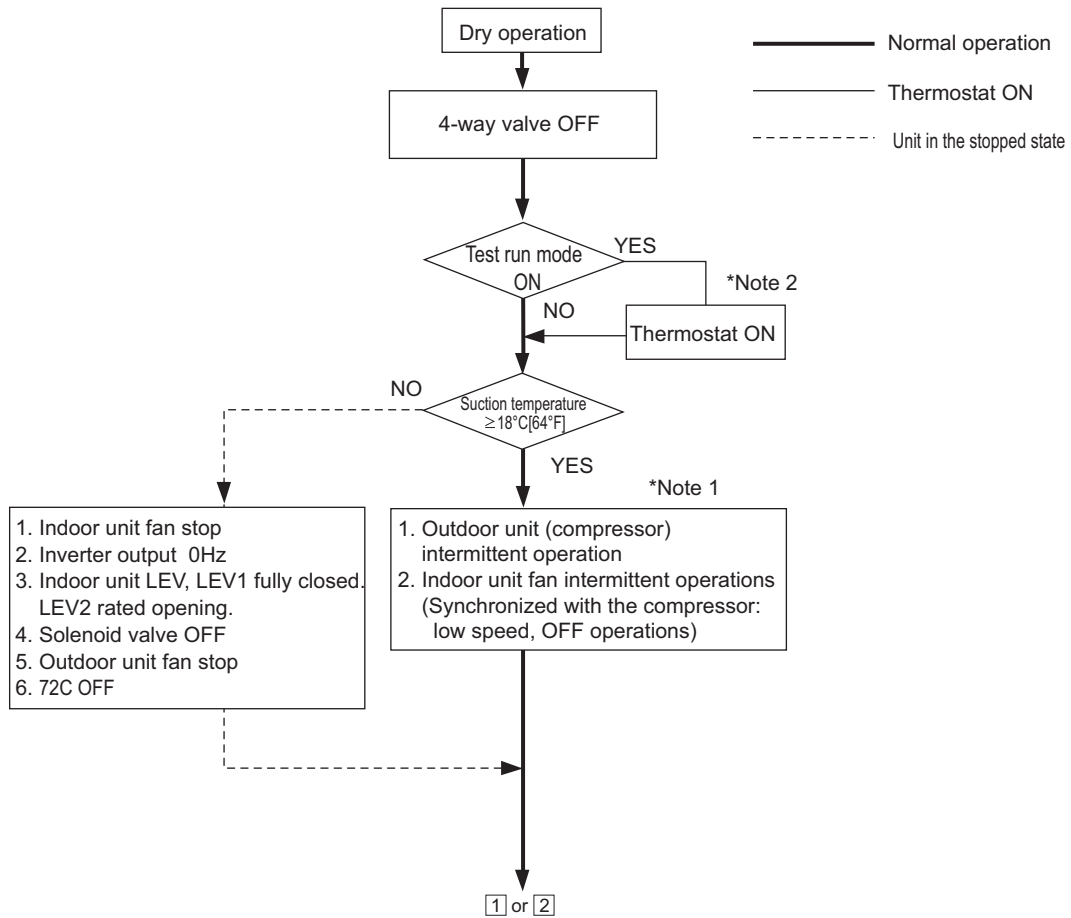

*Note 1. When the indoor unit inlet temperature exceeds 18°C [64°F], the outdoor unit (compressor) and the indoor unit fan start the intermittent operation simultaneously. When the indoor unit inlet temperature becomes 18°C [64°F], or less, the fan always runs (at low speed). The outdoor unit, the indoor unit, and the solenoid valve operate in the same way as they do in the cooling operation when the compressor is turned on.

*Note 2. Thermostat is always kept on during test run mode, and indoor and outdoor unit intermittent operation (ON) time is a little longer than that of normal operation.

VIII Test Run Mode

| | |
|---|-----|
| [1] Items to be checked before a Test Run | 107 |
| [2] Test Run Method | 108 |
| [3] Operating Characteristic and Refrigerant Amount | 109 |
| [4] Adjusting the Refrigerant Amount | 109 |
| [5] Refrigerant Amount Adjust Mode | 112 |
| [6] The following symptoms are normal. | 114 |
| [7] Standard Operation Data (Reference Data) | 115 |

[1] Items to be checked before a Test Run

(1) Check for refrigerant leak and loose cables and connectors.

(2) Measure the insulation resistance between the power supply terminal block and the ground with a 500V megger and make sure it reads at least 1.0Mohm.

Note

- Do not operate the unit if the insulation resistance is below 1.0Mohm.
- Do not apply megger voltage to the terminal block for transmission line. Doing so will damage the controller board.
- The insulation resistance between the power supply terminal block and the ground could go down to close to 1Mohm immediately after installation or when the power is kept off for an extended period of time because of the accumulation of refrigerant in the compressor.
- If insulation resistance reads at least 1Mohm, by turning on the main power and powering the crankcase heater for at least 12 hours, the refrigerant in the compressor will evaporate and the insulation resistance will go up.
- Do not measure the insulation resistance of the terminal block for transmission line for the unit remote controller.

(3) Check that the valve on the gas pipe and liquid pipe are fully open.

Note

Securely tighten the cap.

(4) Check the phase sequence and the voltage of the power supply.

(5) [When a transmission booster is connected]

Turn on the transmission booster before turning on the outdoor units.

Note

- If the outdoor units are turned on first, the connection information for the refrigerant circuit may not be properly recognized.
- In case the outdoor units are turned on before the transmission booster is turned on, perform a power reset on the outdoor units after turning on the power booster.

(6) Turn on the main power to the unit at least 12 hours before test run to power the crankcase heater.

Note

Insufficient powering time may result in compressor damage.

(7) When a power supply unit is connected to the transmission line for centralized control, perform a test run with the power supply unit being energized. Leave the power jumper connector on CN41 as it is (factory setting).

[2] Test Run Method

The figure shows an MA remote controller (PAR-21MAA).

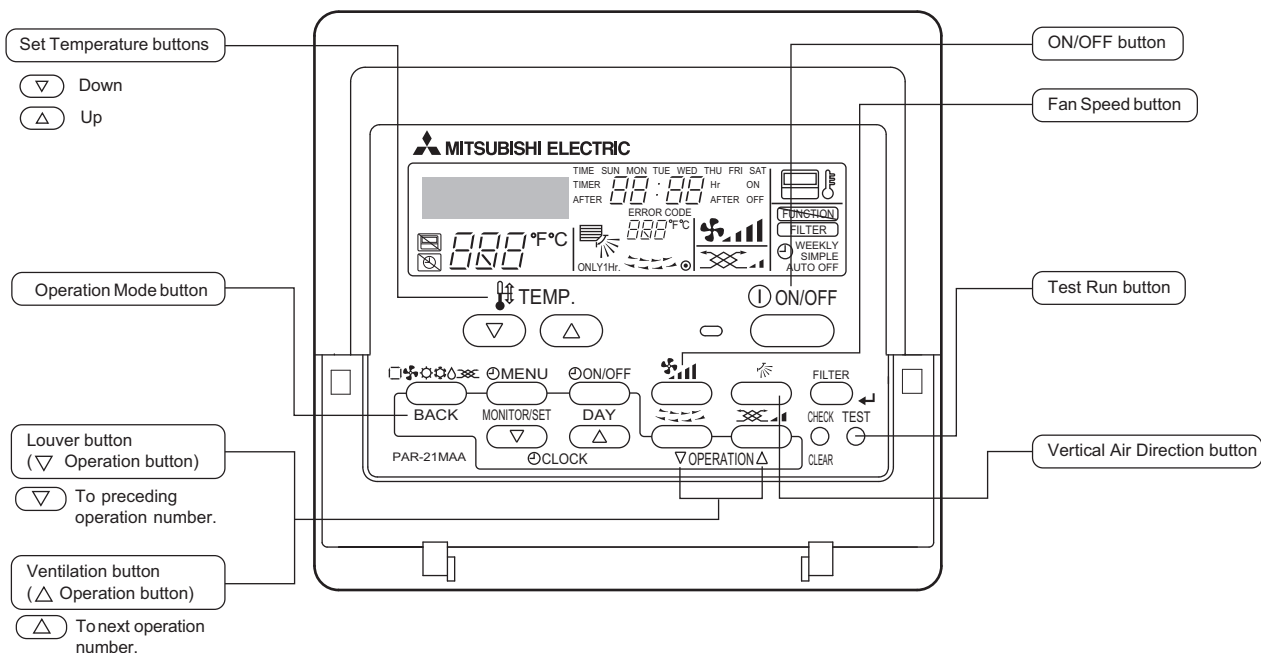

| Operation procedures | |
|--|--|
| Turn on the main power. | → "PLEASE WAIT" appears on the LCD for up to five minutes. Leave the power on for 12 hours. (Energize the crankcase heater.) |
| Press the Test button twice. | → Operation mode display "TEST RUN" and OPERATION MODE are displayed alternately. |
| Press the Operation Mode button. | → Make sure that the air is blowing out. |
| Switch to cooling (or heating) operation by pressing the Operation Mode button. | → Make sure that cold (or warm) air blows out. |
| Press the Fan Speed button. | → Make sure that the fan speed changes with each pressing of the button. |
| Change the air flow direction by pressing the Vertical Air Direction button or the Louver button. | → Make sure that the air flow direction changes with each pressing of the button. |
| | → Confirm the operation of outdoor unit fan. |
| | Confirm the operation of all interlocked equipment, such as ventilation equipment. |
| Cancel the test run by pressing the ON/OFF button. | → Stop |
| Note 1: Refer to the following pages if an error code appears on the remote controller or when the unit malfunctions. 2: The OFF timer will automatically stop the test run after 2 hours. 3: The remaining time for the test run will be displayed in the time display during test run. 4: The temperature of the liquid pipe on the indoor unit will be displayed in the room temperature display window on the remote controller during test run. 5: On some models, "NOT AVAILABLE" may appear on the display when the Vane Control button is pressed. This is normal. 6: If an external input is connected, perform a test run using the external input signal. 7: Perform simultaneous all-system operation for 15 minutes or longer because system error detection may take 15 minutes maximum. | |

[3] Operating Characteristic and Refrigerant Amount

It is important to have a clear understanding of the characteristics of refrigerant and the operating characteristics of air conditioners before attempting to adjust the refrigerant amount in a given system.

1. Operating characteristic and refrigerant amount

The following table shows items of particular importance.

- 1) During cooling operation, the amount of refrigerant in the accumulator is the smallest when all indoor units are in operation.
- 2) During heating operation, the amount of refrigerant in the accumulator is the largest when all indoor units are in operation.
- 3) General tendency of discharge temperature
 - Discharge temperature tends to rise when the system is short on refrigerant.
 - Changing the amount of refrigerant in the system while there is refrigerant in the accumulator has little effect on the discharge temperature.
 - The higher the pressure, the more likely it is for the discharge temperature to rise.
 - The lower the pressure, the more likely it is for the discharge temperature to rise.
- 4) When the amount of refrigerant in the system is adequate, the compressor shell temperature is 10 to 60°C [18 to 108°F] higher than the low pressure saturation temperature (Te).
 - > If the temperature difference between the compressor shell temperature and low pressure saturation temperature (Te) is smaller than 5°C [9°F], an overcharging of refrigerant is suspected.

[4] Adjusting the Refrigerant Amount

1. Symptoms

Overcharging or undercharging of refrigerant can cause the following symptoms:
 Before attempting to adjust the amount of refrigerant in the system, thoroughly check the operating conditions of the system.
 Then, adjust the refrigerant amount by running the unit in the refrigerant amount adjust mode.

| | |
|---|---------------------------------|
| The system comes to an abnormal stop, displaying 1500 (overcharged refrigerant) on the controller. | Overcharged refrigerant |
| The operating frequency does not reach the set frequency, and there is a problem with performance. | Insufficient refrigerant amount |
| The system comes to an abnormal stop, displaying 1102 (abnormal discharge temperature) on the controller. | |

2. Amount of refrigerant

(1) To be checked during operation

Operate all indoor units in either cooling-only or heating-only mode, and check such items as discharge temperature, subcooling, low pressure, suction temperature, and shell bottom temperature to estimate the amount of refrigerant in the system.

| Symptoms | Conclusion |
|--|-----------------------------------|
| Discharge temperature is high. (Normal discharge temperature is below 95°C [203°F].) | Slightly undercharged refrigerant |
| Low pressure is unusually low. | |
| Suction superheat is large. (Normal suction superheat is less than 20°C [36°F].) | |
| Compressor shell bottom temperature is high. (The difference between the compressor shell bottom temperature and low pressure saturation temperature (Te) is greater than 60°C [108°F].) | Slightly overcharged refrigerant |
| Discharge superheat is small. (Normal discharge superheat is greater than 10°C [18°F].) | |
| Compressor shell bottom temperature is low. (The difference between the compressor shell bottom temperature and low pressure saturation temperature (Te) is less than 5°C [9°F].) | |

3. Amount of refrigerant to be added

The amount of refrigerant that is shown in the table below is factory-charged to the outdoor units.
The amount necessary for extended pipe (field piping) is not included and must be added on site.

| Outdoor unit model | P200 | P250 | P300 | P350 | P400 | P450 |
|--|------|-------|-------|------|------|------|
| Amount of pre-charged refrigerant in the outdoor unit (kg) | 6.5 | 9.0 | 9.0 | 11.5 | 11.5 | 11.5 |
| Amount of pre-charged refrigerant in the outdoor unit [lbs-oz] | 14-5 | 19-13 | 19-13 | 25-6 | 25-6 | 25-6 |

(1) Calculation formula

The amount of refrigerant to be added depends on the size and the length of field piping. (unit in m[ft])

| |
|---|
| $\text{Amount of added refrigerant (kg)} = (0.29 \times L_1) + (0.2 \times L_2) + (0.12 \times L_3) + (0.06 \times L_4) + (0.024 \times L_5) + \alpha$ $\text{Amount of added refrigerant (oz)} = (3.12 \times L_1') + (2.15 \times L_2') + (1.29 \times L_3') + (0.65 \times L_4') + (0.26 \times L_5') + \alpha'$ |
|---|

- | | |
|--|--|
| <p>L_1 : Length of $\varnothing 19.05$ [3/4"] liquid pipe (m) L_2 : Length of $\varnothing 15.88$ [5/8"] liquid pipe (m) L_3 : Length of $\varnothing 12.7$ [1/2"] liquid pipe (m) L_4 : Length of $\varnothing 9.52$ [3/8"] liquid pipe (m) L_5 : Length of $\varnothing 6.35$ [1/4"] liquid pipe (m) α, α' : Refer to the table below.</p> | <p>L_1' : Length of $\varnothing 19.05$ [3/4"] liquid pipe [ft] L_2' : Length of $\varnothing 15.88$ [5/8"] liquid pipe [ft] L_3' : Length of $\varnothing 12.7$ [1/2"] liquid pipe [ft] L_4' : Length of $\varnothing 9.52$ [3/8"] liquid pipe [ft] L_5' : Length of $\varnothing 6.35$ [1/4"] liquid pipe [ft]</p> |
|--|--|

| Total capacity of connected indoor units | α (kg) | α' (oz) |
|--|---------------|----------------|
| - 80 | 2.0 | 71 |
| 81 - 160 | 2.5 | 89 |
| 161 - 330 | 3.0 | 106 |
| 331 - 390 | 3.5 | 124 |
| 391 - 480 | 4.5 | 159 |
| 481 - 630 | 5.0 | 177 |
| 631 - 710 | 6.0 | 212 |
| 711 - 800 | 8.0 | 283 |
| 801 - 890 | 9.0 | 318 |
| 891 - 1070 | 10.0 | 353 |
| 1071 - 1250 | 12.0 | 424 |
| 1251 - | 14.0 | 494 |

Round up the calculation result to the nearest 0.1kg. (Example: 18.04kg to 18.1kg)
 Round up the calculation result in increments of 4oz (0.1kg) or round it up to the nearest 1oz.
 (Example: 178.21oz to 179oz)

(2) Example: PUHY-P500YSHA

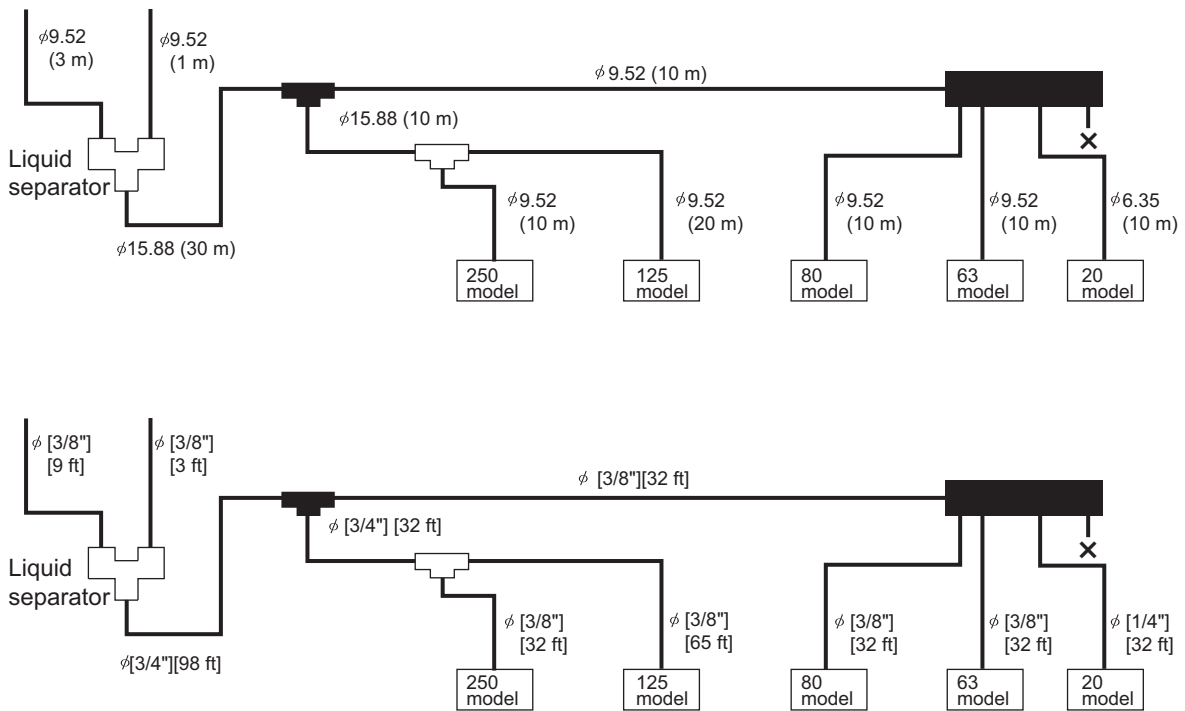

(3) Sample calculation

All the pipes in the figure are liquid pipes.

$\phi 15.88 : 30\text{ m} + 10\text{ m} = 40\text{ m}$

$\phi 9.52 : 3\text{ m} + 1\text{ m} + 10\text{ m} + 10\text{ m} + 20\text{ m} + 10\text{ m} + 10\text{ m} = 64\text{ m}$

$\phi 6.35 : 10\text{ m}$

According to the above formula

Amount of refrigerant to be charged (kg) = $(0.2 \times 40) + (0.06 \times 64) + (0.024 \times 10) + 5.0 = 17.08\text{kg}$

The calculation result would be 17.08, and it is rounded up to the nearest 0.1.

The final result will be as follows:

Amount of refrigerant to be charged = 17.1kg



All the pipes in the figure are liquid pipes.

$\phi [3/4"] : [98\text{ ft}] + [32\text{ ft}] = [130\text{ ft}]$

$\phi [3/8"] : [9\text{ ft}] + [3\text{ ft}] + [32\text{ ft}] + [32\text{ ft}] + [65\text{ ft}] + [32\text{ ft}] + [32\text{ ft}] = [205\text{ ft}]$

$\phi [1/4"] : [32\text{ ft}]$

According to the above formula

Amount of refrigerant to be charged (oz) = $(2.15 \times 130) + (0.65 \times 205) + (0.26 \times 32) + 177 = 598.07\text{oz}$

The calculation result would be 598.07 oz, and it is rounded up to the nearest 1 oz.

The final result will be as follows:

Amount of refrigerant to be charged = 599 oz



⚠ CAUTION

Charge liquid refrigerant (as opposed to gaseous refrigerant) into the system.

- If gaseous refrigerant is charged into the system, the composition of the refrigerant in the cylinder will change and may result in performance loss.

[5] Refrigerant Amount Adjust Mode

1. Procedures

Follow the procedures below to add or extract refrigerant as necessary depending on the operation mode.

When the function switch (SW4-3) on the main board on the outdoor unit (OC only) is turned to ON, the unit goes into the refrigerant amount adjust mode, and the following sequence is followed.

Note

SW4-3 on the OS is invalid, and the unit will not go into the refrigerant amount adjust mode.

Operation

When the unit is in the refrigerant amount adjust mode, the LEV on the indoor unit does not open as fully as it normally does during cooling operation to secure subcooling.

Note

- 1) Adjust the refrigerant amount based on the values of TH4, TH3, TH6, and Tc, following the flowchart below. Check the TH4, TH3, TH6, and Tc values on the OC, OS1, and OS2 by following the flowchart. The TH4, TH3, TH6, and Tc values can be displayed by setting the self-diagnosis switch (SW1) on the main board on the OC, OS1, and OS2.
- 2) There may be cases when the refrigerant amount may seem adequate for a short while after starting the unit in the refrigerant amount adjust mode but turn out to be inadequate later on (when the refrigerant system stabilizes).

When the amount of refrigerant is truly adequate.

TH3-TH6 on the indoor unit is 5°C [9°F] or above and SH on the indoor unit is between 5 and 15°C [9 and 27°F].

The refrigerant amount may seem adequate at the moment, but may turn out to be inadequate later on.

TH3-TH6 on the indoor unit is 5°C [9°F] or less and SH on the indoor unit is 5°C [9°F] or less.

Wait until the TH3-TH6 reaches 5°C [9°F] or above and the SH of the indoor unit is between 5 and 15°C [9 and 27°F] to determine that the refrigerant amount is adequate.

- 3) High pressure must be at least 2.0MPa[290psi] to enable a proper adjustment of refrigerant amount to be made.
- 4) Refrigerant amount adjust mode automatically ends 90 minutes after beginning. When this happens, by turning off the SW4-3 and turning them back on, the unit will go back into the refrigerant amount adjust mode.

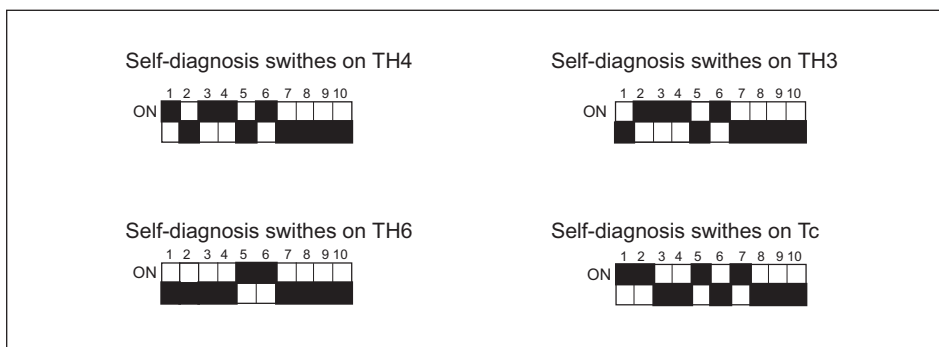

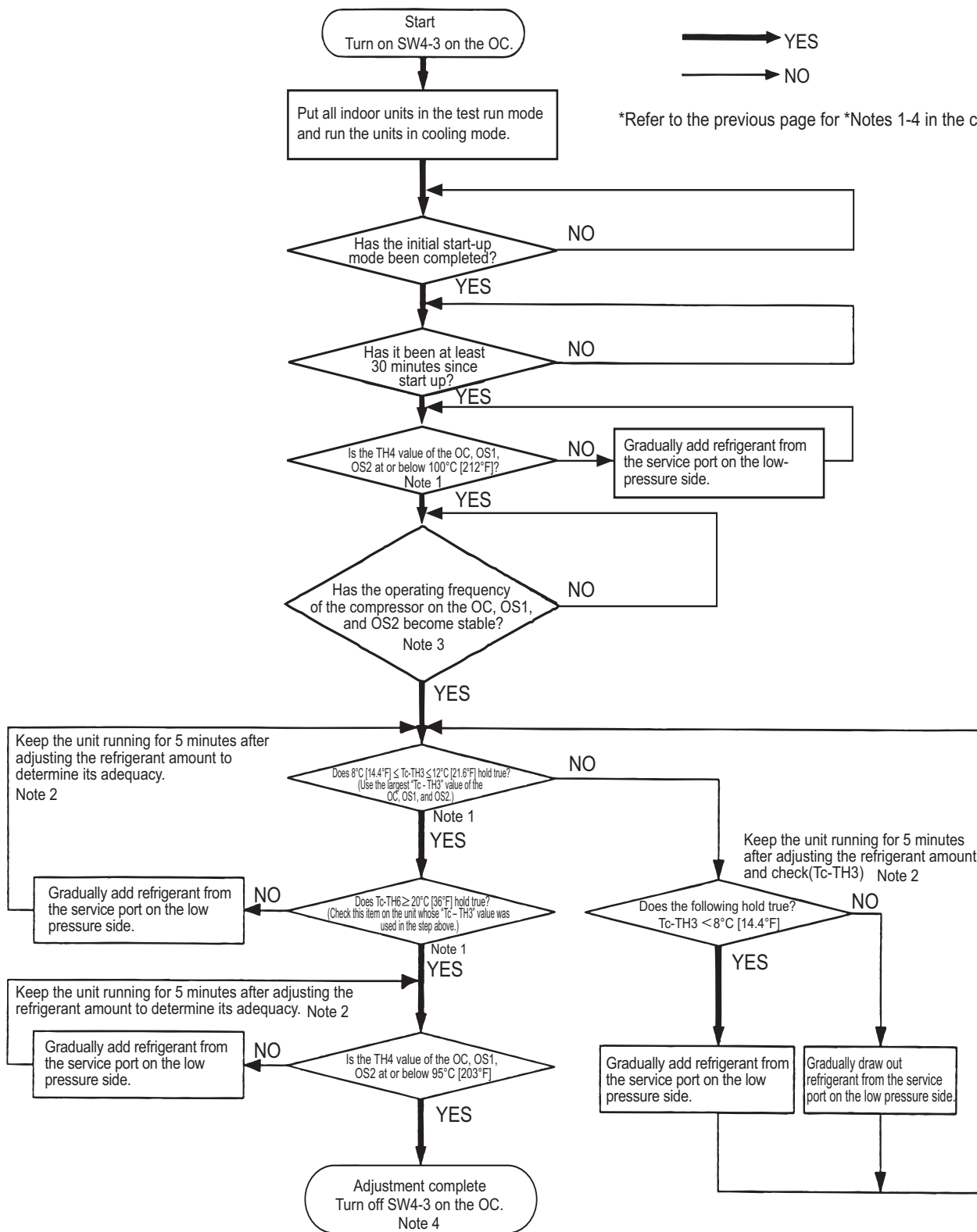

CAUTION
Do not release the extracted refrigerant into the air.

CAUTION
Charge liquid refrigerant (as opposed to gaseous refrigerant) into the system.
•If gaseous refrigerant is charged into the system, the composition of the refrigerant in the cylinder will change and may result in performance loss.

[6] The following symptoms are normal.

| Symptoms | Remote controller display | Cause |
|--|---|--|
| The indoor unit does not start after starting cooling (heating) operation. | "Cooling (heating)" icon blinks on the display. | The unit cannot perform a heating (cooling) operation when other indoor units are performing a cooling (heating) operation. |
| The auto vane adjusts its position by itself. | Normal display | After an hour of cooling operation with the auto vane in the vertical position, the vane may automatically move into the horizontal position. Louver blades will automatically move into the horizontal position while the unit is in the defrost mode, pre-heating stand-by mode, or when the thermostat triggers unit off. |
| The fan stops during heating operation. | Defrost | The fan remains stopped during defrost operation. |
| The fan keeps running after the unit has stopped. | Unlit | When the auxiliary heater is turned on, the fan operates for one minute after stopping to dissipate heat. |
| The fan speed does not reach the set speed when operation switch is turned on. | STAND BY | The fan operates at extra low speed for 5 minutes after it is turned on or until the pipe temperature reaches 35°C[95°F], then it operates at low speed for 2 minutes, and finally it operates at the set speed. (Pre-heating stand-by) |
| When the main power is turned on, the display shown on the right appears on the indoor unit remote controller for 5 minutes. | "HO" or "PLEASE WAIT" icons blink on the display. | The system is starting up. Wait until the blinking display of "HO" or "PLEASE WAIT" go off. |
| The drain pump keeps running after the unit has stopped. | Unlit | The drain pump stays in operation for three minutes after the unit in the cooling mode is stopped. |
| The drain pump is running while the unit is stopped. | | When drain water is detected, the drain pump goes into operation even while the unit is stopped. |
| Indoor unit and BC controller make noise during cooling/heating changeover. | Normal display | This noise is made when the refrigerant circuit is reversed and is normal. |
| Sound of the refrigerant flow is heard from the indoor unit immediately after starting operation. | Normal display | This is caused by the transient instability of the refrigerant flow and is normal. |
| Warm air sometimes comes out of the indoor units that are not in the heating mode. | Normal display | This is due to the fact that the LEVs on some of the indoor units are kept slightly open to prevent the refrigerant in the indoor units that are not operating in the heating mode from liquefying and accumulating in the compressor. It is part of a normal operation. |

[7] Standard Operation Data (Reference Data)

1. Single unit

(1) Cooling operation

| Operation | | | | Outdoor unit model | |
|-----------------------|---|-----------------------------|---------------|--|--------------|
| | | | | PUHY-P200YHA | PUHY-P250YHA |
| Operating conditions | Ambient temperature | Indoor | DB/WB | 27°C/19°C [81°F/66°F] | |
| | | Outdoor | | 35°C/ - [95°F/ -] | |
| | Indoor unit | No. of connected units | Unit | 2 | |
| | | No. of units in operation | | 2 | |
| | | Model | | 100/100 125/125 | |
| | Piping | Main pipe | m [ft] | 5 [16-3/8] | |
| | | Branch pipe | | 10 [32-3/4] | |
| | | Total pipe length | | 25 [82] | |
| | Fan speed | | - | Hi | |
| | Amount of refrigerant | | kg [lbs-oz] | 11 [24] 13.5 [30] | |
| Outdoor unit | Electric current | | A | 9.1 12.3 | |
| | Voltage | | V | 400 400 | |
| | Compressor frequency | | Hz | 52 65 | |
| LEV opening | Indoor unit | | Pulse | 325/325 387/387 | |
| | SC (LEV1) | | | 80 100 | |
| | LEV2 | | | - - | |
| Pressure | High pressure (after O/S)/low pressure (before accumulator) | | MPa [psi] | 2.77/0.74 [402/107] 3.11/0.86 [451/125] | |
| Temp. of each section | Outdoor unit | Discharge (TH4) | °C [°F] | 89 [192] 85 [185] | |
| | | Heat exchanger outlet (TH3) | | 44 [111] 44 [111] | |
| | | Accumulator inlet | | 7 [45] 7 [45] | |
| | | Accumulator outlet | | 7 [45] 7 [45] | |
| | | SCC outlet (TH6) | | 22 [72] 24 [75] | |
| | | Compressor inlet | | 19 [66] 19 [66] | |
| | | Compressor shell bottom | | 47 [117] 38 [100] | |
| | Indoor unit | LEV inlet | | 22 [72] 24 [75] | |
| | | Heat exchanger outlet | | 6 [43] 6 [43] | |

| Operation | | | | Outdoor unit model | |
|-----------------------|---|-----------------------------|---------------|-------------------------|-------------------------|
| | | | | PUHY-P300YHA | PUHY-P350YHA |
| Operating conditions | Ambient temperature | Indoor | DB/WB | 27°C/19°C [81°F/66°F] | 27°C/19°C [81°F/66°F] |
| | | Outdoor | | 35°C/ - [95°F/ -] | 35°C/ - [95°F/ -] |
| | Indoor unit | No. of connected units | Unit | 3 | 3 |
| | | No. of units in operation | | 3 | 3 |
| | | Model | | - | 100/100/100 |
| | Piping | Main pipe | m [ft] | 5 [16-3/8] | 5 [16-3/8] |
| | | Branch pipe | | 10 [32-3/4] | 10 [32-3/4] |
| | | Total pipe length | | 35 [114-13/16] | 35 [114-13/16] |
| | Fan speed | | - | Hi | Hi |
| | Amount of refrigerant | | kg [lbs-oz] | 15 [33] | 17.5 [39] |
| Outdoor unit | Electric current | | A | 14.5 | 17.9 |
| | Voltage | | V | 400 | 400 |
| | Compressor frequency | | Hz | 74 | 95 |
| LEV opening | Indoor unit | | Pulse | 325/325/325 | 325/387/387 |
| | SC (LEV1) | | | 100 | 100 |
| | LEV2 | | | - | - |
| Pressure | High pressure (after O/S)/low pressure (before accumulator) | | MPa [psi] | 2.95/0.84 [428/122] | 2.86/0.76 [415/110] |
| Temp. of each section | Outdoor unit | Discharge (TH4) | °C [°F] | 84 [183] | 90 [194] |
| | | Heat exchanger outlet (TH3) | | 44 [111] | 43 [109] |
| | | Accumulator inlet | | 7 [45] | 7 [45] |
| | | Accumulator outlet | | 7 [45] | 7 [45] |
| | | SCC outlet (TH6) | | 22 [72] | 22 [72] |
| | | Compressor inlet | | 19 [66] | 19 [66] |
| | | Compressor shell bottom | | 42 [108] | 42 [108] |
| | Indoor unit | LEV inlet | | 22 [72] | 22 [72] |
| | | Heat exchanger outlet | | 6 [43] | 6 [43] |

| Operation | | | | Outdoor unit model | |
|-----------------------|---|-----------------------------|---------------|-------------------------|-------------------------|
| | | | | PUHY-P400YHA | PUHY-P450YHA |
| Operating conditions | Ambient temperature | Indoor | DB/WB | 27°C/19°C [81°F/66°F] | 27°C/19°C [81°F/66°F] |
| | | Outdoor | | 35°C/ - [95°F/ -] | 35°C/ - [95°F/ -] |
| | Indoor unit | No. of connected units | Unit | 4 | 4 |
| | | No. of units in operation | | 4 | 4 |
| | | Model | | - | 100/100/100/100 |
| | Piping | Main pipe | m [ft] | 5 [16-3/8] | 5 [16-3/8] |
| | | Branch pipe | | 10 [32-3/4] | 10 [32-3/4] |
| | | Total pipe length | | 45 [147-5/8] | 45 [147-5/8] |
| | Fan speed | | - | Hi | Hi |
| | Amount of refrigerant | | kg [lbs-oz] | 19 [42] | 19 [42] |
| Outdoor unit | Electric current | | A | 21.2 | 26.7 |
| | Voltage | | V | 400 | 400 |
| | Compressor frequency | | Hz | 97 | 111 |
| LEV opening | Indoor unit | | Pulse | 325/325/325/325 | 325/325/387/387 |
| | SC (LEV1) | | | 190 | 190 |
| | LEV2 | | | - | - |
| Pressure | High pressure (after O/S)/low pressure (before accumulator) | | MPa [psi] | 3.05/0.84 [442/122] | 3.07/0.79 [445/115] |
| Temp. of each section | Outdoor unit | Discharge (TH4) | °C [°F] | 82 [180] | 85 [185] |
| | | Heat exchanger outlet (TH3) | | 45 [113] | 48 [118] |
| | | Accumulator inlet | | 7 [45] | 7 [45] |
| | | Accumulator outlet | | 7 [45] | 7 [45] |
| | | SCC outlet (TH6) | | 25 [77] | 28 [82] |
| | | Compressor inlet | | 19 [66] | 19 [66] |
| | | Compressor shell bottom | | 38 [100] | 40 [104] |
| | Indoor unit | LEV inlet | | 25 [77] | 28 [82] |
| | | Heat exchanger outlet | | 4 [39] | 4 [39] |

(2) Heating operation

| Operation | | | | Outdoor unit model | |
|-----------------------|---|-----------------------------|---------------|-----------------------|-----------------------|
| | | | | PUHY-P200YHA | PUHY-P250YHA |
| Operating conditions | Ambient temperature | Indoor | DB/WB | 20°C/ - [68°F/ -] | 20°C/ - [68°F/ -] |
| | | Outdoor | | 7°C/6°C [45°F/43°F] | 7°C/6°C [45°F/43°F] |
| | Indoor unit | No. of connected units | Unit | 2 | 2 |
| | | No. of units in operation | | 2 | 2 |
| | | Model | | - | 100/100 |
| | Piping | Main pipe | m [ft] | 5 [16-3/8] | 5 [16-3/8] |
| | | Branch pipe | | 10 [32-3/4] | 10 [32-3/4] |
| | | Total pipe length | | 25 [82] | 25 [82] |
| | Fan speed | | - | Hi | Hi |
| | Amount of refrigerant | | kg [lbs-oz] | 11 [24] | 13.5 [30] |
| Outdoor unit | Electric current | | A | 9.6 | 12.5 |
| | Voltage | | V | 400 | 400 |
| | Compressor frequency | | Hz | 53 | 71 |
| LEV opening | Indoor unit | | Pulse | 332/332 | 406/406 |
| | SC (LEV1) | | | 0 | 0 |
| | LEV2 | | | - | - |
| Pressure | High pressure (after O/S)/low pressure (before accumulator) | | MPa [psi] | 2.81/0.66 [408/96] | 2.85/0.61 [413/88] |
| Temp. of each section | Outdoor unit | Discharge (TH4) | °C [°F] | 82 [180] | 82 [180] |
| | | Heat exchanger outlet (TH3) | | 0 [32] | 0 [32] |
| | | Accumulator inlet | | -2 [28] | -2 [28] |
| | | Accumulator outlet | | -2 [28] | -2 [28] |
| | | Compressor inlet | | -2 [28] | -2 [28] |
| | | Compressor shell bottom | | 40 [104] | 40 [104] |
| | Indoor unit | LEV inlet | | 37 [99] | 38 [100] |
| | | Heat exchanger outlet | | 80 [176] | 80 [176] |

| Operation | | | | Outdoor unit model | |
|-----------------------|---|-----------------------------|---------------|-----------------------|-----------------------|
| | | | | PUHY-P300YHA | PUHY-P350YHA |
| Operating conditions | Ambient temperature | Indoor | DB/WB | 20°C/ - [68°F/ -] | 20°C/ - [68°F/ -] |
| | | Outdoor | | 7°C/6°C [45°F/43°F] | 7°C/6°C [45°F/43°F] |
| | Indoor unit | No. of connected units | Unit | 3 | 3 |
| | | No. of units in operation | | 3 | 3 |
| | | Model | | - | 100/100/100 |
| | Piping | Main pipe | m [ft] | 5 [16-3/8] | 5 [16-3/8] |
| | | Branch pipe | | 10 [32-3/4] | 10 [32-3/4] |
| | | Total pipe length | | 35 [114-13/16] | 35 [114-13/16] |
| | Fan speed | | - | Hi | Hi |
| | Amount of refrigerant | | kg [lbs-oz] | 15 [33] | 17.5 [39] |
| Outdoor unit | Electric current | | A | 15.0 | 19.3 |
| | Voltage | | V | 400 | 400 |
| | Compressor frequency | | Hz | 81 | 101 |
| LEV opening | Indoor unit | | Pulse | 332/332/332 | 332/406/406 |
| | SC (LEV1) | | | 0 | 0 |
| | LEV2 | | | - | - |
| Pressure | High pressure (after O/S)/low pressure (before accumulator) | | MPa [psi] | 2.78/0.61 [403/88] | 2.81/0.57 [408/83] |
| Temp. of each section | Outdoor unit | Discharge (TH4) | °C [°F] | 82 [180] | 82 [180] |
| | | Heat exchanger outlet (TH3) | | -1 [30] | -1 [30] |
| | | Accumulator inlet | | -3 [27] | -3 [27] |
| | | Accumulator outlet | | -3 [27] | -3 [27] |
| | | Compressor inlet | | -3 [27] | -3 [27] |
| | | Compressor shell bottom | | 40 [104] | 40 [104] |
| | Indoor unit | LEV inlet | | 39 [102] | 39 [102] |
| | | Heat exchanger outlet | | 80 [176] | 80 [176] |

| Operation | | | | Outdoor unit model | |
|-----------------------|---|-----------------------------|---------------|-----------------------|-----------------------|
| | | | | PUHY-P400YHA | PUHY-P450YHA |
| Operating conditions | Ambient temperature | Indoor | DB/WB | 20°C/ - [68°F/ -] | 20°C/ - [68°F/ -] |
| | | Outdoor | | 7°C/6°C [45°F/43°F] | 7°C/6°C [45°F/43°F] |
| | Indoor unit | No. of connected units | Unit | 4 | 4 |
| | | No. of units in operation | | 4 | 4 |
| | | Model | | - | 100/100/100/100 |
| | Piping | Main pipe | m [ft] | 5 [16-3/8] | 5 [16-3/8] |
| | | Branch pipe | | 10 [32-3/4] | 10 [32-3/4] |
| | | Total pipe length | | 45 [147-5/8] | 45 [147-5/8] |
| | Fan speed | | - | Hi | Hi |
| | Amount of refrigerant | | kg [lbs-oz] | 19 [42] | 19 [42] |
| Outdoor unit | Electric current | | A | 21.6 | 25.4 |
| | Voltage | | V | 400 | 400 |
| | Compressor frequency | | Hz | 102 | 117 |
| LEV opening | Indoor unit | | Pulse | 332/332/332/332 | 332/332/406/406 |
| | SC (LEV1) | | | 0 | 0 |
| | LEV2 | | | - | - |
| Pressure | High pressure (after O/S)/low pressure (before accumulator) | | MPa [psi] | 2.74/0.61 [397/88] | 2.81/0.61 [408/88] |
| Temp. of each section | Outdoor unit | Discharge (TH4) | °C [°F] | 89 [192] | 89 [192] |
| | | Heat exchanger outlet (TH3) | | -1 [30] | -1 [30] |
| | | Accumulator inlet | | -3 [27] | -3 [27] |
| | | Accumulator outlet | | -3 [27] | -3 [27] |
| | | Compressor inlet | | -3 [27] | -3 [27] |
| | | Compressor shell bottom | | 40 [104] | 40 [104] |
| | Indoor unit | LEV inlet | | 37 [99] | 37 [99] |
| | | Heat exchanger outlet | | 80 [176] | 80 [176] |

2. 2-unit combination

(1) Cooling operation

| Operation | | | | Outdoor unit model | |
|-----------------------|---|-----------------------------|---------------|-------------------------|-----------------------|
| | | | | PUHY-P500YSHA | |
| | | | | PUHY-P250YHA | PUHY-P250YHA |
| Operating conditions | Ambient temperature | Indoor | DB/WB | 27°C/19°C [81°F/66°F] | |
| | | Outdoor | | 35°C/ - [95°F/ -] | |
| | Indoor unit | No. of connected units | Unit | 4 | |
| | | No. of units in operation | | 4 | |
| | | Model | | 125/125/125/125 | |
| | Piping | Main pipe | m [ft] | 5 [16-3/8] | |
| | | Branch pipe | | 10 [32-3/4] | |
| | | Total pipe length | | 45 [147-5/8] | |
| | Fan speed | | - | Hi | |
| | Amount of refrigerant | | kg [lbs-oz] | 27 [60] | |
| Outdoor unit | Electric current | | A | 26.4 | |
| | Voltage | | V | 400 | |
| | Compressor frequency | | Hz | 65 | 65 |
| LEV opening | Indoor unit | | Pulse | 387/387/387/387 | |
| | SC (LEV1) | | | 100 | 100 |
| | LEV2 | | | 1400 | 1400 |
| Pressure | High pressure (after O/S)/low pressure (before accumulator) | | MPa [psi] | 3.11/0.86 [451/125] | 3.11/0.86 [451/125] |
| Temp. of each section | Outdoor unit | Discharge (TH4) | °C [°F] | 85 [185] | 85 [185] |
| | | Heat exchanger outlet (TH3) | | 47 [117] | 47 [117] |
| | | Accumulator inlet | | 7 [45] | 7 [45] |
| | | Accumulator outlet | | 7 [45] | 7 [45] |
| | | SCC outlet (TH6) | | 27 [81] | 27 [81] |
| | | Compressor inlet | | 19 [66] | 19 [66] |
| | | Compressor shell bottom | | 38 [100] | 38 [100] |
| | Indoor unit | LEV inlet | | 27 [81] | |
| | | Heat exchanger outlet | | 6 [43] | |

| Operation | | | | Outdoor unit model | |
|-----------------------|---|-----------------------------|---------------|-------------------------|-----------------------|
| | | | | PUHY-P550YSHA | |
| | | | | PUHY-P250YHA | PUHY-P300YHA |
| Operating conditions | Ambient temperature | Indoor | DB/WB | 27°C/19°C [81°F/66°F] | |
| | | Outdoor | | 35°C/ - [95°F/ -] | |
| | Indoor unit | No. of connected units | Unit | 6 | |
| | | No. of units in operation | | 6 | |
| | | Model | | 20/100/100/100/125/125 | |
| | Piping | Main pipe | m [ft] | 5 [16-3/8] | |
| | | Branch pipe | | 10 [32-3/4] | |
| | | Total pipe length | | 65 [213-1/4] | |
| | Fan speed | | - | Hi | |
| | Amount of refrigerant | | kg [lbs-oz] | 27.5 [61] | |
| Outdoor unit | Electric current | | A | 29.4 | |
| | Voltage | | V | 400 | |
| | Compressor frequency | | Hz | 65 | 71 |
| LEV opening | Indoor unit | | Pulse | 222/325/325/325/387/387 | |
| | SC (LEV1) | | | 159 | 237 |
| | LEV2 | | | 1400 | 1400 |
| Pressure | High pressure (after O/S)/low pressure (before accumulator) | | MPa [psi] | 3.10/0.78 [450/113] | 3.10/0.74 [450/107] |
| Temp. of each section | Outdoor unit | Discharge (TH4) | °C [°F] | 91 [196] | 89 [192] |
| | | Heat exchanger outlet (TH3) | | 47 [117] | 47 [117] |
| | | Accumulator inlet | | 7 [45] | 7 [45] |
| | | Accumulator outlet | | 7 [45] | 7 [45] |
| | | SCC outlet (TH6) | | 27 [81] | 27 [81] |
| | | Compressor inlet | | 19 [66] | 19 [66] |
| | | Compressor shell bottom | | 42 [108] | 42 [108] |
| | Indoor unit | LEV inlet | | 27 [81] | |
| | | Heat exchanger outlet | | 6 [43] | |

| Operation | | | | Outdoor unit model | |
|-----------------------|---|-----------------------------|---------------|-------------------------|-----------------------|
| | | | | PUHY-P600YSHA | |
| | | | | PUHY-P250YHA | PUHY-P350YHA |
| Operating conditions | Ambient temperature | Indoor | DB/WB | 27°C/19°C [81°F/66°F] | |
| | | Outdoor | | 35°C/- [95°F/-] | |
| | Indoor unit | No. of connected units | Unit | 6 | |
| | | No. of units in operation | | 6 | |
| | | Model | | 50/100/100/100/125/125 | |
| | Piping | Main pipe | m [ft] | 5 [16-3/8] | |
| | | Branch pipe | | 10 [32-3/4] | |
| | | Total pipe length | | 65 [213-1/4] | |
| | Fan speed | | - | Hi | |
| | Amount of refrigerant | | kg [lbs-oz] | 30 [66] | |
| Outdoor unit | Electric current | | A | 30.0 | |
| | Voltage | | V | 400 | |
| | Compressor frequency | | Hz | 65 | 92 |
| LEV opening | Indoor unit | | Pulse | 362/325/325/325/387/387 | |
| | SC (LEV1) | | | 159 | 237 |
| | LEV2 | | | 1400 | 1400 |
| Pressure | High pressure (after O/S)/low pressure (before accumulator) | | MPa [psi] | 3.10/0.74 [450/107] | 3.10/0.78 [450/113] |
| Temp. of each section | Outdoor unit | Discharge (TH4) | °C [°F] | 91 [196] | 91 [196] |
| | | Heat exchanger outlet (TH3) | | 47 [117] | 47 [117] |
| | | Accumulator inlet | | 7 [45] | 7 [45] |
| | | Accumulator outlet | | 7 [45] | 7 [45] |
| | | SCC outlet (TH6) | | 27 [81] | 27 [81] |
| | | Compressor inlet | | 19 [66] | 19 [66] |
| | | Compressor shell bottom | | 42 [108] | 42 [108] |
| | Indoor unit | LEV inlet | | 27 [81] | |
| | | Heat exchanger outlet | | 6 [43] | |

| Operation | | | | Outdoor unit model | |
|-----------------------|---|-----------------------------|---------------|-------------------------|-----------------------|
| | | | | PUHY-P650YSHA | |
| | | | | PUHY-P300YHA | PUHY-P350YHA |
| Operating conditions | Ambient temperature | Indoor | DB/WB | 27°C/19°C [81°F/66°F] | |
| | | Outdoor | | 35°C/ - [95°F/ -] | |
| | Indoor unit | No. of connected units | Unit | 6 | |
| | | No. of units in operation | | 6 | |
| | | Model | | 100/100/100/100/125/125 | |
| | Piping | Main pipe | m [ft] | 5 [16-3/8] | |
| | | Branch pipe | | 10 [32-3/4] | |
| | | Total pipe length | | 65 [213-1/4] | |
| | Fan speed | | - | Hi | |
| | Amount of refrigerant | | kg [lbs-oz] | 31.5 [69] | |
| Outdoor unit | Electric current | | A | 33.3 | |
| | Voltage | | V | 400 | |
| | Compressor frequency | | Hz | 84 | 85 |
| LEV opening | Indoor unit | | Pulse | 325/325/325/325/387/387 | |
| | SC (LEV1) | | | 105 | 105 |
| | LEV2 | | | 1400 | 1400 |
| Pressure | High pressure (after O/S)/low pressure (before accumulator) | | MPa [psi] | 2.86/0.69 [415/100] | 2.86/0.69 [415/100] |
| Temp. of each section | Outdoor unit | Discharge (TH4) | °C [°F] | 90 [194] | 90 [194] |
| | | Heat exchanger outlet (TH3) | | 43 [109] | 43 [109] |
| | | Accumulator inlet | | 7 [45] | 7 [45] |
| | | Accumulator outlet | | 7 [45] | 7 [45] |
| | | SCC outlet (TH6) | | 24 [75] | 24 [75] |
| | | Compressor inlet | | 19 [66] | 19 [66] |
| | | Compressor shell bottom | | 48 [118] | 48 [118] |
| | Indoor unit | LEV inlet | | 24 [75] | |
| | | Heat exchanger outlet | | 6 [43] | |

| Operation | | | | Outdoor unit model | |
|-----------------------|---|-----------------------------|---------------|-------------------------|-----------------------|
| | | | | PUHY-P700YSHA | |
| | | | | PUHY-P350YHA | PUHY-P350YHA |
| Operating conditions | Ambient temperature | Indoor | DB/WB | 27°C/19°C [81°F/66°F] | |
| | | Outdoor | | 35°C/ - [95°F/ -] | |
| | Indoor unit | No. of connected units | Unit | 6 | |
| | | No. of units in operation | | 6 | |
| | | Model | | 100/100/125/125/125/125 | |
| | Piping | Main pipe | m [ft] | 5 [16-3/8] | |
| | | Branch pipe | | 10 [32-3/4] | |
| | | Total pipe length | | 65 [213-1/4] | |
| | Fan speed | | - | Hi | |
| | Amount of refrigerant | | kg [lbs-oz] | 36 [79] | |
| Outdoor unit | Electric current | | A | 36.0 | |
| | Voltage | | V | 400 | |
| | Compressor frequency | | Hz | 95 | 95 |
| LEV opening | Indoor unit | | Pulse | 325/325/387/387/387/387 | |
| | SC (LEV1) | | | 105 | 105 |
| | LEV2 | | | 1400 | 1400 |
| Pressure | High pressure (after O/S)/low pressure (before accumulator) | | MPa [psi] | 2.86/0.69 [415/100] | 2.86/0.69 [415/100] |
| Temp. of each section | Outdoor unit | Discharge (TH4) | °C [°F] | 90 [194] | 90 [194] |
| | | Heat exchanger outlet (TH3) | | 43 [109] | 43 [109] |
| | | Accumulator inlet | | 7 [45] | 7 [45] |
| | | Accumulator outlet | | 7 [45] | 7 [45] |
| | | SCC outlet (TH6) | | 24 [75] | 24 [75] |
| | | Compressor inlet | | 19 [66] | 19 [66] |
| | | Compressor shell bottom | | 48 [118] | 48 [118] |
| | Indoor unit | LEV inlet | | 24 [75] | |
| | | Heat exchanger outlet | | 6 [43] | |

| Operation | | | | Outdoor unit model | |
|-----------------------|---|-----------------------------|---------------|-------------------------|-----------------------|
| | | | | PUHY-P750YSHA | |
| | | | | PUHY-P350YHA | PUHY-P400YHA |
| Operating conditions | Ambient temperature | Indoor | DB/WB | 27°C/19°C [81°F/66°F] | |
| | | Outdoor | | 35°C/ - [95°F/ -] | |
| | Indoor unit | No. of connected units | Unit | 6 | |
| | | No. of units in operation | | 6 | |
| | | Model | | 125/125/125/125/125/125 | |
| | Piping | Main pipe | m [ft] | 5 [16-3/8] | |
| | | Branch pipe | | 10 [32-3/4] | |
| | | Total pipe length | | 65 [213-1/4] | |
| | Fan speed | | - | Hi | |
| | Amount of refrigerant | | kg [lbs-oz] | 36.5 [80] | |
| Outdoor unit | Electric current | | A | 40.2 | |
| | Voltage | | V | 400 | |
| | Compressor frequency | | Hz | 96 | 96 |
| LEV opening | Indoor unit | | Pulse | 387/387/387/387/387/387 | |
| | SC (LEV1) | | | 141 | 185 |
| | LEV2 | | | 1400 | 1400 |
| Pressure | High pressure (after O/S)/low pressure (before accumulator) | | MPa [psi] | 2.95/0.81 [428/117] | 2.86/0.76 [415/110] |
| Temp. of each section | Outdoor unit | Discharge (TH4) | °C [°F] | 96 [204] | 95 [202] |
| | | Heat exchanger outlet (TH3) | | 47 [117] | 46 [114] |
| | | Accumulator inlet | | 7 [45] | 7 [45] |
| | | Accumulator outlet | | 7 [45] | 7 [45] |
| | | SCC outlet (TH6) | | 25 [77] | 24 [75] |
| | | Compressor inlet | | 19 [66] | 19 [66] |
| | | Compressor shell bottom | | 56 [132] | 47 [117] |
| | Indoor unit | LEV inlet | | 25 [77] | |
| | | Heat exchanger outlet | | 4 [39] | |

| Operation | | | | Outdoor unit model | |
|-----------------------|---|-----------------------------|---------------|-------------------------|-----------------------|
| | | | | PUHY-P800YSHA | |
| | | | | PUHY-P350YHA | PUHY-P450YHA |
| Operating conditions | Ambient temperature | Indoor | DB/WB | 27°C/19°C [81°F/66°F] | |
| | | Outdoor | | 35°C/ - [95°F/ -] | |
| | Indoor unit | No. of connected units | Unit | 6 | |
| | | No. of units in operation | | 6 | |
| | | Model | | 125/125/125/140/140/140 | |
| | Piping | Main pipe | m [ft] | 5 [16-3/8] | |
| | | Branch pipe | | 10 [32-3/4] | |
| | | Total pipe length | | 65 [213-1/4] | |
| | Fan speed | | - | Hi | |
| | Amount of refrigerant | | kg [lbs-oz] | 36.5 [80] | |
| Outdoor unit | Electric current | | A | 44.4 | |
| | Voltage | | V | 400 | |
| | Compressor frequency | | Hz | 103 | 103 |
| LEV opening | Indoor unit | | Pulse | 387/387/387/310/310/310 | |
| | SC (LEV1) | | | 141 | 185 |
| | LEV2 | | | 1400 | 1400 |
| Pressure | High pressure (after O/S)/low pressure (before accumulator) | | MPa [psi] | 2.95/0.81 [428/117] | 2.86/0.76 [415/110] |
| Temp. of each section | Outdoor unit | Discharge (TH4) | °C [°F] | 96 [204] | 95 [202] |
| | | Heat exchanger outlet (TH3) | | 47 [117] | 46 [114] |
| | | Accumulator inlet | | 7 [45] | 7 [45] |
| | | Accumulator outlet | | 7 [45] | 7 [45] |
| | | SCC outlet (TH6) | | 25 [77] | 24 [75] |
| | | Compressor inlet | | 19 [66] | 19 [66] |
| | | Compressor shell bottom | | 56 [132] | 47 [117] |
| | Indoor unit | LEV inlet | | 25 [77] | |
| | | Heat exchanger outlet | | 4 [39] | |

| Operation | | | | Outdoor unit model | |
|-----------------------|---|-----------------------------|---------------|-------------------------|-----------------------|
| | | | | PUHY-P850YSHA | |
| | | | | PUHY-P400YHA | PUHY-P450YHA |
| Operating conditions | Ambient temperature | Indoor | DB/WB | 27°C/19°C [81°F/66°F] | |
| | | Outdoor | | 35°C/ - [95°F/ -] | |
| | Indoor unit | No. of connected units | Unit | 6 | |
| | | No. of units in operation | | 6 | |
| | | Model | | 140/140/140/140/140/140 | |
| | Piping | Main pipe | m [ft] | 5 [16-3/8] | |
| | | Branch pipe | | 10 [32-3/4] | |
| | | Total pipe length | | 65 [213-1/4] | |
| | Fan speed | | - | Hi | |
| | Amount of refrigerant | | kg [lbs-oz] | 37 [82] | |
| Outdoor unit | Electric current | | A | 49.5 | |
| | Voltage | | V | 400 | |
| | Compressor frequency | | Hz | 104 | 104 |
| LEV opening | Indoor unit | | Pulse | 395/395/395/395/395/395 | |
| | SC (LEV1) | | | 171 | 171 |
| | LEV2 | | | 1400 | 1400 |
| Pressure | High pressure (after O/S)/low pressure (before accumulator) | | MPa [psi] | 3.12/0.83 [453/120] | 3.12/0.83 [453/120] |
| Temp. of each section | Outdoor unit | Discharge (TH4) | °C [°F] | 98 [208] | 98 [208] |
| | | Heat exchanger outlet (TH3) | | 47 [117] | 47 [117] |
| | | Accumulator inlet | | 7 [45] | 7 [45] |
| | | Accumulator outlet | | 7 [45] | 7 [45] |
| | | SCC outlet (TH6) | | 26 [79] | 26 [79] |
| | | Compressor inlet | | 20 [68] | 20 [68] |
| | | Compressor shell bottom | | 47 [117] | 47 [117] |
| | Indoor unit | LEV inlet | | 26 [79] | |
| | | Heat exchanger outlet | | 4 [39] | |

| Operation | | | | Outdoor unit model | |
|-----------------------|---|-----------------------------|---------------|-----------------------------|-----------------------|
| | | | | PUHY-P900YSHA | |
| | | | | PUHY-P450YHA | PUHY-P450YHA |
| Operating conditions | Ambient temperature | Indoor | DB/WB | 27°C/19°C [81°F/66°F] | |
| | | Outdoor | | 35°C/ - [95°F/ -] | |
| | Indoor unit | No. of connected units | Unit | 7 | |
| | | No. of units in operation | | 7 | |
| | | Model | | 100/100/100/125/125/125/125 | |
| | Piping | Main pipe | m [ft] | 5 [16-3/8] | |
| | | Branch pipe | | 10 [32-3/4] | |
| | | Total pipe length | | 75 [246-1/16] | |
| | Fan speed | | - | Hi | |
| | Amount of refrigerant | | kg [lbs-oz] | 39 [86] | |
| Outdoor unit | Electric current | | A | 54.7 | |
| | Voltage | | V | 400 | |
| | Compressor frequency | | Hz | 111 | 111 |
| LEV opening | Indoor unit | | Pulse | 325/325/325/387/387/387/387 | |
| | SC (LEV1) | | | 171 | 171 |
| | LEV2 | | | 1400 | 1400 |
| Pressure | High pressure (after O/S)/low pressure (before accumulator) | | MPa [psi] | 3.12/0.83 [453/120] | 3.12/0.83 [453/120] |
| Temp. of each section | Outdoor unit | Discharge (TH4) | °C [°F] | 98 [208] | 98 [208] |
| | | Heat exchanger outlet (TH3) | | 47 [117] | 47 [117] |
| | | Accumulator inlet | | 7 [45] | 7 [45] |
| | | Accumulator outlet | | 7 [45] | 7 [45] |
| | | SCC outlet (TH6) | | 26 [79] | 26 [79] |
| | | Compressor inlet | | 20 [68] | 20 [68] |
| | | Compressor shell bottom | | 47 [117] | 47 [117] |
| | Indoor unit | LEV inlet | | 26 [79] | |
| | | Heat exchanger outlet | | 4 [39] | |

(2) Heating operation

| Operation | | | | Outdoor unit model | |
|-----------------------|---|-----------------------------|---------------|------------------------|----------------------|
| | | | | PUHY-P500YSHA | |
| | | | | PUHY-P250YHA | PUHY-P250YHA |
| Operating conditions | Ambient temperature | Indoor | DB/WB | 20°C/ - [68°F/ -] | |
| | | Outdoor | | 7°C/ 6°C [45°F/43°F] | |
| | Indoor unit | No. of connected units | Unit | 4 | |
| | | No. of units in operation | | 4 | |
| | | Model | | 125/125/125/125 | |
| | Piping | Main pipe | m [ft] | 5 [16-3/8] | |
| | | Branch pipe | | 10 [32-3/4] | |
| | | Total pipe length | | 45 [147-5/8] | |
| | Fan speed | | - | Hi | |
| | Amount of refrigerant | | kg [lbs-oz] | 27 [60] | |
| Outdoor unit | Electric current | | A | 26.3 | |
| | Voltage | | V | 400 | |
| | Compressor frequency | | Hz | 71 | 71 |
| LEV opening | Indoor unit | | Pulse | 406/406/406/406 | |
| | SC (LEV1) | | | 0 | |
| | LEV2 | | | 1400 | 1400 |
| Pressure | High pressure (after O/S)/low pressure (before accumulator) | | MPa [psi] | 2.81/0.66 [408/99] | 2.81/0.66 [408/99] |
| Temp. of each section | Outdoor unit | Discharge (TH4) | °C [°F] | 82 [180] | 82 [180] |
| | | Heat exchanger outlet (TH3) | | 0 [32] | 0 [32] |
| | | Accumulator inlet | | -2 [28] | -2 [28] |
| | | Accumulator outlet | | -2 [28] | -2 [28] |
| | | Compressor inlet | | -2 [28] | -2 [28] |
| | | Compressor shell bottom | | 40 [104] | 40 [104] |
| | Indoor unit | LEV inlet | | 37 [99] | |
| | | Heat exchanger outlet | | 80 [176] | |

| Operation | | | | Outdoor unit model | |
|-----------------------|---|-----------------------------|---------------|-------------------------|----------------------|
| | | | | PUHY-P550YSHA | |
| | | | | PUHY-P250YHA | PUHY-P300YHA |
| Operating conditions | Ambient temperature | Indoor | DB/WB | 20°C/ - [68°F/ -] | |
| | | Outdoor | | 7°C/ 6°C [45°F/43°F] | |
| | Indoor unit | No. of connected units | Unit | 6 | |
| | | No. of units in operation | | 6 | |
| | | Model | | 20/100/100/100/125/125 | |
| | Piping | Main pipe | m [ft] | 5 [16-3/8] | |
| | | Branch pipe | | 10 [32-3/4] | |
| | | Total pipe length | | 65 [213-1/4] | |
| | Fan speed | | - | Hi | |
| | Amount of refrigerant | | kg [lbs-oz] | 27.5 [61] | |
| Outdoor unit | Electric current | | A | 28.9 | |
| | Voltage | | V | 400 | |
| | Compressor frequency | | Hz | 71 | 79 |
| LEV opening | Indoor unit | | Pulse | 229/332/332/332/406/406 | |
| | SC (LEV1) | | | 0 | |
| | LEV2 | | | 1400 | 1400 |
| Pressure | High pressure (after O/S)/low pressure (before accumulator) | | MPa [psi] | 2.61/0.61 [379/88] | 2.68/0.57 [389/83] |
| Temp. of each section | Outdoor unit | Discharge (TH4) | °C [°F] | 82 [180] | 83 [181] |
| | | Heat exchanger outlet (TH3) | | 0 [32] | 0 [32] |
| | | Accumulator inlet | | -2 [28] | -2 [28] |
| | | Accumulator outlet | | -2 [28] | -2 [28] |
| | | Compressor inlet | | -2 [28] | -2 [28] |
| | | Compressor shell bottom | | 30 [86] | 34 [93] |
| | Indoor unit | LEV inlet | | 35 [95] | |
| | | Heat exchanger outlet | | 80 [176] | |

| Operation | | | | Outdoor unit model | |
|-----------------------|---|-----------------------------|---------------|-------------------------|----------------------|
| | | | | PUHY-P600YSHA | |
| | | | | PUHY-P250YHA | PUHY-P350YHA |
| Operating conditions | Ambient temperature | Indoor | DB/WB | 20°C/ - [68°F/ -] | |
| | | Outdoor | | 7°C/6°C [45°F/43°F] | |
| | Indoor unit | No. of connected units | Unit | 6 | |
| | | No. of units in operation | | 6 | |
| | | Model | | 50/100/100/100/125/125 | |
| | Piping | Main pipe | m [ft] | 5 [16-3/8] | |
| | | Branch pipe | | 10 [32-3/4] | |
| | | Total pipe length | | 65 [213-1/4] | |
| | Fan speed | | - | Hi | |
| | Amount of refrigerant | | kg [lbs-oz] | 30 [66] | |
| Outdoor unit | Electric current | | A | 31.9 | |
| | Voltage | | V | 400 | |
| | Compressor frequency | | Hz | 71 | 99 |
| LEV opening | Indoor unit | | Pulse | 373/332/332/332/406/406 | |
| | SC (LEV1) | | | 0 | |
| | LEV2 | | | 1400 | 1400 |
| Pressure | High pressure (after O/S)/low pressure (before accumulator) | | MPa [psi] | 2.61/0.61 [379/88] | 2.76/0.57 [400/83] |
| Temp. of each section | Outdoor unit | Discharge (TH4) | °C [°F] | 82 [180] | 86 [187] |
| | | Heat exchanger outlet (TH3) | | 0 [32] | 0 [32] |
| | | Accumulator inlet | | -2 [28] | -2 [28] |
| | | Accumulator outlet | | -2 [28] | -2 [28] |
| | | Compressor inlet | | -2 [28] | -2 [28] |
| | | Compressor shell bottom | | 30 [86] | 34 [93] |
| | Indoor unit | LEV inlet | | 35 [95] | |
| | | Heat exchanger outlet | | 80 [176] | |

| Operation | | | | Outdoor unit model | |
|-----------------------|---|-----------------------------|---------------|-------------------------|----------------------|
| | | | | PUHY-P650YSHA | |
| | | | | PUHY-P300YHA | PUHY-P350YHA |
| Operating conditions | Ambient temperature | Indoor | DB/WB | 20°C/ - [68°F/ -] | |
| | | Outdoor | | 7°C/6°C [45°F/43°F] | |
| | Indoor unit | No. of connected units | Unit | 6 | |
| | | No. of units in operation | | 6 | |
| | | Model | | 100/100/100/100/125/125 | |
| | Piping | Main pipe | m [ft] | 5 [16-3/8] | |
| | | Branch pipe | | 10 [32-3/4] | |
| | | Total pipe length | | 65 [213-1/4] | |
| | Fan speed | | - | Hi | |
| | Amount of refrigerant | | kg [lbs-oz] | 31.5 [69] | |
| Outdoor unit | Electric current | | A | 35.1 | |
| | Voltage | | V | 400 | |
| | Compressor frequency | | Hz | 91 | 91 |
| LEV opening | Indoor unit | | Pulse | 350/350/340/340/330/330 | |
| | SC (LEV1) | | | 0 | |
| | LEV2 | | | 1400 | 1400 |
| Pressure | High pressure (after O/S)/low pressure (before accumulator) | | MPa [psi] | 2.59/0.57 [376/83] | 2.59/0.57 [376/83] |
| Temp. of each section | Outdoor unit | Discharge (TH4) | °C [°F] | 82 [180] | 82 [180] |
| | | Heat exchanger outlet (TH3) | | 0 [32] | 0 [32] |
| | | Accumulator inlet | | -2 [28] | -2 [28] |
| | | Accumulator outlet | | -2 [28] | -2 [28] |
| | | Compressor inlet | | -2 [28] | -2 [28] |
| | | Compressor shell bottom | | 22 [72] | 22 [72] |
| | Indoor unit | LEV inlet | | 35 [95] | |
| | | Heat exchanger outlet | | 80 [176] | |

| Operation | | | | Outdoor unit model | |
|-----------------------|---|-----------------------------|---------------|-------------------------|----------------------|
| | | | | PUHY-P700YSHA | |
| | | | | PUHY-P350YHA | PUHY-P350YHA |
| Operating conditions | Ambient temperature | Indoor | DB/WB | 20°C/ - [68°F/ -] | |
| | | Outdoor | | 7°C/6°C [45°F/43°F] | |
| | Indoor unit | No. of connected units | Unit | 6 | |
| | | No. of units in operation | | 6 | |
| | | Model | | 100/100/125/125/125/125 | |
| | Piping | Main pipe | m [ft] | 5 [16-3/8] | |
| | | Branch pipe | | 10 [32-3/4] | |
| | | Total pipe length | | 65 [213-1/4] | |
| | Fan speed | | - | Hi | |
| | Amount of refrigerant | | kg [lbs-oz] | 36 [79] | |
| Outdoor unit | Electric current | | A | 38.0 | |
| | Voltage | | V | 400 | |
| | Compressor frequency | | Hz | 101 | 101 |
| LEV opening | Indoor unit | | Pulse | 332/332/406/406/406/406 | |
| | SC (LEV1) | | | 0 | |
| | LEV2 | | | 1400 | 1400 |
| Pressure | High pressure (after O/S)/low pressure (before accumulator) | | MPa [psi] | 2.59/0.57 [376/83] | 2.59/0.57 [376/83] |
| Temp. of each section | Outdoor unit | Discharge (TH4) | °C [°F] | 82 [180] | 82 [180] |
| | | Heat exchanger outlet (TH3) | | 0 [32] | 0 [32] |
| | | Accumulator inlet | | -2 [28] | -2 [28] |
| | | Accumulator outlet | | -2 [28] | -2 [28] |
| | | Compressor inlet | | -2 [28] | -2 [28] |
| | | Compressor shell bottom | | 22 [72] | 22 [72] |
| | Indoor unit | LEV inlet | | 35 [95] | |
| | | Heat exchanger outlet | | 80 [176] | |

| Operation | | | | Outdoor unit model | |
|-----------------------|---|-----------------------------|---------------|-------------------------|----------------------|
| | | | | PUHY-P750YSHA | |
| | | | | PUHY-P350YHA | PUHY-P400YHA |
| Operating conditions | Ambient temperature | Indoor | DB/WB | 20°C/ - [68°F/ -] | |
| | | Outdoor | | 7°C/6°C [45°F/43°F] | |
| | Indoor unit | No. of connected units | Unit | 6 | |
| | | No. of units in operation | | 6 | |
| | | Model | | 125/125/125/125/125/125 | |
| | Piping | Main pipe | m [ft] | 5 [16-3/8] | |
| | | Branch pipe | | 10 [32-3/4] | |
| | | Total pipe length | | 65 [213-1/4] | |
| | Fan speed | | - | Hi | |
| | Amount of refrigerant | | kg [lbs-oz] | 36.5 [80] | |
| Outdoor unit | Electric current | | A | 40.8 | |
| | Voltage | | V | 400 | |
| | Compressor frequency | | Hz | 101 | 102 |
| LEV opening | Indoor unit | | Pulse | 332/332/406/406/406/406 | |
| | SC (LEV1) | | | 0 | |
| | LEV2 | | | 1160 | 1280 |
| Pressure | High pressure (after O/S)/low pressure (before accumulator) | | MPa [psi] | 2.90/0.62 [421/90] | 2.91/0.60 [422/87] |
| Temp. of each section | Outdoor unit | Discharge (TH4) | °C [°F] | 82 [180] | 89 [192] |
| | | Heat exchanger outlet (TH3) | | -1 [30] | -2 [28] |
| | | Accumulator inlet | | -3 [26] | -4 [25] |
| | | Accumulator outlet | | -3 [26] | -4 [25] |
| | | Compressor inlet | | -3 [26] | -4 [25] |
| | | Compressor shell bottom | | 30 [85] | 40 [104] |
| | Indoor unit | LEV inlet | | 39 [102] | |
| | | Heat exchanger outlet | | 80 [176] | |

| Operation | | | | Outdoor unit model | |
|-----------------------|---|-----------------------------|---------------|-------------------------|----------------------|
| | | | | PUHY-P800YSHA | |
| | | | | PUHY-P350YHA | PUHY-P450YHA |
| Operating conditions | Ambient temperature | Indoor | DB/WB | 20°C/ - [68°F/ -] | |
| | | Outdoor | | 7°C/6°C [45°F/43°F] | |
| | Indoor unit | No. of connected units | Unit | 6 | |
| | | No. of units in operation | | 6 | |
| | | Model | | 125/125/125/140/140/140 | |
| | Piping | Main pipe | m [ft] | 5 [16-3/8] | |
| | | Branch pipe | | 10 [32-3/4] | |
| | | Total pipe length | | 65 [213-1/4] | |
| | Fan speed | | - | Hi | |
| | Amount of refrigerant | | kg [lbs-oz] | 36.5 [80] | |
| Outdoor unit | Electric current | | A | 50.8 | |
| | Voltage | | V | 400 | |
| | Compressor frequency | | Hz | 109 | 109 |
| LEV opening | Indoor unit | | Pulse | 406/406/406/414/414/414 | |
| | SC (LEV1) | | | 0 | |
| | LEV2 | | | 1160 | 1280 |
| Pressure | High pressure (after O/S)/low pressure (before accumulator) | | MPa [psi] | 2.90/0.62 [421/90] | 2.91/0.60 [422/87] |
| Temp. of each section | Outdoor unit | Discharge (TH4) | °C [°F] | 82 [180] | 89 [192] |
| | | Heat exchanger outlet (TH3) | | -1 [30] | -2 [28] |
| | | Accumulator inlet | | -3 [26] | -4 [25] |
| | | Accumulator outlet | | -3 [26] | -4 [25] |
| | | Compressor inlet | | -3 [26] | -4 [25] |
| | | Compressor shell bottom | | 30 [85] | 40 [104] |
| | Indoor unit | LEV inlet | | 39 [102] | |
| | | Heat exchanger outlet | | 80 [176] | |

| Operation | | | | Outdoor unit model | |
|-----------------------|---|-----------------------------|---------------|-------------------------|----------------------|
| | | | | PUHY-P850YSHA | |
| | | | | PUHY-P400YHA | PUHY-P450YHA |
| Operating conditions | Ambient temperature | Indoor | DB/WB | 20°C/ - [68°F/ -] | |
| | | Outdoor | | 7°C/6°C [45°F/43°F] | |
| | Indoor unit | No. of connected units | Unit | 6 | |
| | | No. of units in operation | | 6 | |
| | | Model | | 140/140/140/140/140/140 | |
| | Piping | Main pipe | m [ft] | 5 [16-3/8] | |
| | | Branch pipe | | 10 [32-3/4] | |
| | | Total pipe length | | 65 [213-1/4] | |
| | Fan speed | | - | Hi | |
| | Amount of refrigerant | | kg [lbs-oz] | 37 [82] | |
| Outdoor unit | Electric current | | A | 47.8 | |
| | Voltage | | V | 400 | |
| | Compressor frequency | | Hz | 109 | 110 |
| LEV opening | Indoor unit | | Pulse | 414/414/414/414/414/414 | |
| | SC (LEV1) | | | 0 | |
| | LEV2 | | | 1280 | 1280 |
| Pressure | High pressure (after O/S)/low pressure (before accumulator) | | MPa [psi] | 2.91/0.60 [422/87] | 2.91/0.60 [422/87] |
| Temp. of each section | Outdoor unit | Discharge (TH4) | °C [°F] | 89 [192] | 89 [192] |
| | | Heat exchanger outlet (TH3) | | -2 [28] | -2 [28] |
| | | Accumulator inlet | | -4 [25] | -4 [25] |
| | | Accumulator outlet | | -4 [25] | -4 [25] |
| | | Compressor inlet | | -4 [25] | -4 [25] |
| | | Compressor shell bottom | | 40 [104] | 40 [104] |
| | Indoor unit | LEV inlet | | 39 [102] | |
| | | Heat exchanger outlet | | 80 [176] | |

| Operation | | | | Outdoor unit model | |
|-----------------------|---|-----------------------------|---------------|-----------------------------|----------------------|
| | | | | PUHY-P900YSHA | |
| | | | | PUHY-P450YHA | PUHY-P450YHA |
| Operating conditions | Ambient temperature | Indoor | DB/WB | 20°C/ - [68°F/ -] | |
| | | Outdoor | | 7°C/6°C [45°F/43°F] | |
| | Indoor unit | No. of connected units | Unit | 7 | |
| | | No. of units in operation | | 7 | |
| | | Model | | 100/100/100/125/125/125/125 | |
| | Piping | Main pipe | m [ft] | 5 [16-3/8] | |
| | | Branch pipe | | 10 [32-3/4] | |
| | | Total pipe length | | 75 [246-1/16] | |
| | Fan speed | | - | Hi | |
| | Amount of refrigerant | | kg [lbs-oz] | 39 [86] | |
| Outdoor unit | Electric current | | A | 50.8 | |
| | Voltage | | V | 400 | |
| | Compressor frequency | | Hz | 117 | 117 |
| LEV opening | Indoor unit | | Pulse | 332/332/332/406/406/406/406 | |
| | SC (LEV1) | | | 0 | |
| | LEV2 | | | 1280 | 1280 |
| Pressure | High pressure (after O/S)/low pressure (before accumulator) | | MPa [psi] | 2.91/0.60 [422/87] | 2.91/0.60 [422/87] |
| Temp. of each section | Outdoor unit | Discharge (TH4) | °C [°F] | 89 [192] | 89 [192] |
| | | Heat exchanger outlet (TH3) | | -2 [28] | -2 [28] |
| | | Accumulator inlet | | -4 [25] | -4 [25] |
| | | Accumulator outlet | | -4 [25] | -4 [25] |
| | | Compressor inlet | | -4 [25] | -4 [25] |
| | | Compressor shell bottom | | 40 [104] | 40 [104] |
| | Indoor unit | LEV inlet | | 39 [102] | |
| | | Heat exchanger outlet | | 80 [176] | |

3. 3-unit combination
(1) Cooling operation

| Operation | | | | Outdoor unit model | | |
|-----------------------|---|-----------------------------|---------------|---------------------------------|------------------------------|-----------------------|
| | | | | PUHY-P950YSHA | | |
| | | | | PUHY-P250YHA | PUHY-P300YHA | PUHY-P400YHA |
| Operating conditions | Ambient temperature | Indoor | DB/WB | 27°C/19°C [81°F/66°F] | | |
| | | Outdoor | | 35°C/ - [95°F/ -] | | |
| | Indoor unit | No. of connected units | Unit | 8 | | |
| | | No. of units in operation | | 8 | | |
| | | Model | | - | 250/200/200/125/100/32/32/25 | |
| | Piping | Main pipe | m [ft] | 5 [16-3/8] | | |
| | | Branch pipe | | 10 [32-3/4] | | |
| | | Total pipe length | | 85 [278-13/16] | | |
| | Fan speed | | - | Hi | | |
| | Amount of refrigerant | | kg [lbs-oz] | 44.5 [98] | | |
| Outdoor unit | Electric current | | A | 49.2 | | |
| | Voltage | | V | 400 | | |
| | Compressor frequency | | Hz | 65 | 84 | 84 |
| LEV opening | Indoor unit | | Pulse | 388/324/324/387/325/261/261/222 | | |
| | SC (LEV1) | | | 130 | 141 | 116 |
| | LEV2 | | | 1400 | 1400 | 1400 |
| Pressure | High pressure (after O/S)/low pressure (before accumulator) | | MPa [psi] | 3.06/0.79 [444/115] | 2.95/0.81 [428/117] | 2.86/0.76 [415/110] |
| Temp. of each section | Outdoor unit | Discharge (TH4) | °C [°F] | 89 [193] | 96 [204] | 95 [202] |
| | | Heat exchanger outlet (TH3) | | 49 [119] | 47 [117] | 46 [114] |
| | | Accumulator inlet | | 7 [45] | 7 [45] | 7 [45] |
| | | Accumulator outlet | | 7 [45] | 7 [45] | 7 [45] |
| | | SCC outlet (TH6) | | 27 [80] | 25 [77] | 24 [75] |
| | | Compressor inlet | | 19 [66] | 19 [66] | 19 [66] |
| | | Compressor shell bottom | | 47 [117] | 56 [132] | 47 [117] |
| | Indoor unit | LEV inlet | | 27 [80] | | |
| | | Heat exchanger outlet | | 6 [43] | | |

| Operation | | | | Outdoor unit model | | |
|-----------------------|---|-----------------------------|---------------|---------------------------------|-----------------------------|-----------------------|
| | | | | PUHY-P1000YSHA | | |
| | | | | PUHY-P300YHA | PUHY-P300YHA | PUHY-P400YHA |
| Operating conditions | Ambient temperature | Indoor | DB/WB | 27°C/19°C [81°F/66°F] | | |
| | | Outdoor | | 35°C/ - [95°F/ -] | | |
| | Indoor unit | No. of connected units | Unit | 8 | | |
| | | No. of units in operation | | 8 | | |
| | | Model | | - | 250/250/200/125/63/63/32/25 | |
| | Piping | Main pipe | m [ft] | 5 [16-3/8] | | |
| | | Branch pipe | | 10 [32-3/4] | | |
| | | Total pipe length | | 85 [278-13/16] | | |
| | Fan speed | | - | Hi | | |
| | Amount of refrigerant | | kg [lbs-oz] | 45 [99] | | |
| Outdoor unit | Electric current | | A | 52.0 | | |
| | Voltage | | V | 400 | | |
| | Compressor frequency | | Hz | 81 | 82 | 82 |
| LEV opening | Indoor unit | | Pulse | 388/388/324/387/441/441/261/222 | | |
| | SC (LEV1) | | | 130 | 141 | 138 |
| | LEV2 | | | 1400 | 1400 | 1400 |
| Pressure | High pressure (after O/S)/low pressure (before accumulator) | | MPa [psi] | 2.95/0.81 [428/117] | 2.95/0.81 [428/117] | 2.86/0.76 [415/110] |
| Temp. of each section | Outdoor unit | Discharge (TH4) | °C [°F] | 96 [204] | 96 [204] | 95 [202] |
| | | Heat exchanger outlet (TH3) | | 47 [117] | 47 [117] | 46 [114] |
| | | Accumulator inlet | | 7 [45] | 7 [45] | 7 [45] |
| | | Accumulator outlet | | 7 [45] | 7 [45] | 7 [45] |
| | | SCC outlet (TH6) | | 25 [77] | 25 [77] | 24 [75] |
| | | Compressor inlet | | 19 [66] | 19 [66] | 19 [66] |
| | | Compressor shell bottom | | 56 [132] | 56 [132] | 47 [117] |
| | Indoor unit | LEV inlet | | 25 [77] | | |
| | | Heat exchanger outlet | | 6 [43] | | |

| Operation | | | | Outdoor unit model | | | |
|-----------------------|---|-----------------------------|---------------|---------------------------------|------------------------------|-----------------------|--|
| | | | | PUHY-P1050YSHA | | | |
| | | | | PUHY-P300YHA | PUHY-P350YHA | PUHY-P400YHA | |
| Operating conditions | Ambient temperature | Indoor | DB/WB | 27°C/19°C [81°F/66°F] | | | |
| | | Outdoor | | 35°C/ - [95°F/ -] | | | |
| | Indoor unit | No. of connected units | Unit | 8 | | | |
| | | No. of units in operation | | 8 | | | |
| | | Model | | - | 250/250/200/125/100/71/32/25 | | |
| | Piping | Main pipe | m [ft] | 5 [16-3/8] | | | |
| | | Branch pipe | | 10 [32-3/4] | | | |
| | | Total pipe length | | 85 [278-13/16] | | | |
| | Fan speed | | - | Hi | | | |
| | Amount of refrigerant | | kg [lbs-oz] | 47.5 [105] | | | |
| Outdoor unit | Electric current | | A | 54.3 | | | |
| | Voltage | | V | 400 | | | |
| | Compressor frequency | | Hz | 88 | 89 | 89 | |
| LEV opening | Indoor unit | | Pulse | 388/388/324/387/325/253/261/222 | | | |
| | SC (LEV1) | | | 141 | 141 | 185 | |
| | LEV2 | | | 1400 | 1400 | 1400 | |
| Pressure | High pressure (after O/S)/low pressure (before accumulator) | | MPa [psi] | 2.95/0.81 [428/117] | 2.95/0.81 [428/117] | 2.86/0.76 [415/110] | |
| Temp. of each section | Outdoor unit | Discharge (TH4) | °C [°F] | 96 [204] | 96 [204] | 95 [202] | |
| | | Heat exchanger outlet (TH3) | | 47 [117] | 47 [117] | 46 [114] | |
| | | Accumulator inlet | | 7 [45] | 7 [45] | 7 [45] | |
| | | Accumulator outlet | | 7 [45] | 7 [45] | 7 [45] | |
| | | SCC outlet (TH6) | | 25 [77] | 25 [77] | 24 [75] | |
| | | Compressor inlet | | 19 [66] | 19 [66] | 19 [66] | |
| | | Compressor shell bottom | | 56 [132] | 56 [132] | 47 [117] | |
| | Indoor unit | LEV inlet | | 25 [77] | | | |
| | | Heat exchanger outlet | | 6 [43] | | | |

| Operation | | | | Outdoor unit model | | | |
|-----------------------|---|-----------------------------|---------------|---------------------------------|------------------------------|-----------------------|--|
| | | | | PUHY-P1100YSHA | | | |
| | | | | PUHY-P350YHA | PUHY-P350YHA | PUHY-P400YHA | |
| Operating conditions | Ambient temperature | Indoor | DB/WB | 27°C/19°C [81°F/66°F] | | | |
| | | Outdoor | | 35°C/ - [95°F/ -] | | | |
| | Indoor unit | No. of connected units | Unit | 8 | | | |
| | | No. of units in operation | | 8 | | | |
| | | Model | | - | 250/250/200/200/100/50/32/25 | | |
| | Piping | Main pipe | m [ft] | 5 [16-3/8] | | | |
| | | Branch pipe | | 10 [32-3/4] | | | |
| | | Total pipe length | | 85 [278-13/16] | | | |
| | Fan speed | | - | Hi | | | |
| | Amount of refrigerant | | kg [lbs-oz] | 52 [115] | | | |
| Outdoor unit | Electric current | | A | 57.4 | | | |
| | Voltage | | V | 400 | | | |
| | Compressor frequency | | Hz | 95 | 96 | 96 | |
| LEV opening | Indoor unit | | Pulse | 388/388/324/324/325/362/261/222 | | | |
| | SC (LEV1) | | | 141 | 141 | 185 | |
| | LEV2 | | | 1400 | 1400 | 1400 | |
| Pressure | High pressure (after O/S)/low pressure (before accumulator) | | MPa [psi] | 2.95/0.81 [428/117] | 2.95/0.81 [428/117] | 2.86/0.76 [415/110] | |
| Temp. of each section | Outdoor unit | Discharge (TH4) | °C [°F] | 96 [204] | 96 [204] | 95 [202] | |
| | | Heat exchanger outlet (TH3) | | 47 [117] | 47 [117] | 46 [114] | |
| | | Accumulator inlet | | 7 [45] | 7 [45] | 7 [45] | |
| | | Accumulator outlet | | 7 [45] | 7 [45] | 7 [45] | |
| | | SCC outlet (TH6) | | 25 [77] | 25 [77] | 24 [75] | |
| | | Compressor inlet | | 19 [66] | 19 [66] | 19 [66] | |
| | | Compressor shell bottom | | 56 [132] | 56 [132] | 47 [117] | |
| | Indoor unit | LEV inlet | | 25 [77] | | | |
| | | Heat exchanger outlet | | 6 [43] | | | |

| Operation | | | | Outdoor unit model | | |
|-----------------------|---|-----------------------------|---------------|---------------------------------|------------------------------|-----------------------|
| | | | | PUHY-P1150YSHA | | |
| | | | | PUHY-P350YHA | PUHY-P350YHA | PUHY-P450YHA |
| Operating conditions | Ambient temperature | Indoor | DB/WB | 27°C/19°C [81°F/66°F] | | |
| | | Outdoor | | 35°C/ - [95°F/ -] | | |
| | Indoor unit | No. of connected units | Unit | 8 | | |
| | | No. of units in operation | | 8 | | |
| | | Model | | - | 250/250/200/200/100/50/32/25 | |
| | Piping | Main pipe | m [ft] | 5 [16-3/8] | | |
| | | Branch pipe | | 10 [32-3/4] | | |
| | | Total pipe length | | 85 [278-13/16] | | |
| | Fan speed | | - | Hi | | |
| | Amount of refrigerant | | kg [lbs-oz] | 52 [115] | | |
| Outdoor unit | Electric current | | A | 63.1 | | |
| | Voltage | | V | 400 | | |
| | Compressor frequency | | Hz | 100 | 100 | 101 |
| LEV opening | Indoor unit | | Pulse | 388/388/324/324/325/362/261/222 | | |
| | SC (LEV1) | | | 141 | 141 | 185 |
| | LEV2 | | | 1400 | 1400 | 1400 |
| Pressure | High pressure (after O/S)/low pressure (before accumulator) | | MPa [psi] | 2.95/0.81 [428/117] | 2.95/0.81 [428/117] | 2.86/0.76 [415/110] |
| Temp. of each section | Outdoor unit | Discharge (TH4) | °C [°F] | 96 [204] | 96 [204] | 95 [202] |
| | | Heat exchanger outlet (TH3) | | 47 [117] | 47 [117] | 46 [114] |
| | | Accumulator inlet | | 7 [45] | 7 [45] | 7 [45] |
| | | Accumulator outlet | | 7 [45] | 7 [45] | 7 [45] |
| | | SCC outlet (TH6) | | 25 [77] | 25 [77] | 24 [75] |
| | | Compressor inlet | | 19 [66] | 19 [66] | 19 [66] |
| | | Compressor shell bottom | | 56 [132] | 56 [132] | 47 [117] |
| | Indoor unit | LEV inlet | | 25 [77] | | |
| | | Heat exchanger outlet | | 6 [43] | | |

| Operation | | | | Outdoor unit model | | |
|-----------------------|---|-----------------------------|---------------|---------------------------------|------------------------------|-----------------------|
| | | | | PUHY-P1200YSHA | | |
| | | | | PUHY-P350YHA | PUHY-P400YHA | PUHY-P450YHA |
| Operating conditions | Ambient temperature | Indoor | DB/WB | 27°C/19°C [81°F/66°F] | | |
| | | Outdoor | | 35°C/ - [95°F/ -] | | |
| | Indoor unit | No. of connected units | Unit | 8 | | |
| | | No. of units in operation | | 8 | | |
| | | Model | | - | 250/250/250/250/100/50/32/32 | |
| | Piping | Main pipe | m [ft] | 5 [16-3/8] | | |
| | | Branch pipe | | 10 [32-3/4] | | |
| | | Total pipe length | | 85 [278-13/16] | | |
| | Fan speed | | - | Hi | | |
| | Amount of refrigerant | | kg [lbs-oz] | 51.5 [114] | | |
| Outdoor unit | Electric current | | A | 66.8 | | |
| | Voltage | | V | 400 | | |
| | Compressor frequency | | Hz | 101 | 101 | 101 |
| LEV opening | Indoor unit | | Pulse | 388/388/388/388/325/362/261/261 | | |
| | SC (LEV1) | | | 141 | 185 | 185 |
| | LEV2 | | | 1400 | 1400 | 1400 |
| Pressure | High pressure (after O/S)/low pressure (before accumulator) | | MPa [psi] | 2.95/0.81 [428/117] | 2.86/0.76 [415/110] | 2.86/0.76 [415/110] |
| Temp. of each section | Outdoor unit | Discharge (TH4) | °C [°F] | 96 [204] | 95 [202] | 95 [202] |
| | | Heat exchanger outlet (TH3) | | 47 [117] | 46 [114] | 46 [114] |
| | | Accumulator inlet | | 7 [45] | 7 [45] | 7 [45] |
| | | Accumulator outlet | | 7 [45] | 7 [45] | 7 [45] |
| | | SCC outlet (TH6) | | 25 [77] | 24 [75] | 24 [75] |
| | | Compressor inlet | | 19 [66] | 19 [66] | 19 [66] |
| | | Compressor shell bottom | | 56 [132] | 47 [117] | 47 [117] |
| | Indoor unit | LEV inlet | | 25 [77] | | |
| | | Heat exchanger outlet | | 4 [40] | | |

| Operation | | | | Outdoor unit model | | | |
|-----------------------|---|-----------------------------|---------------|---------------------------------|-------------------------------|-----------------------|--|
| | | | | PUHY-P1250YSHA | | | |
| | | | | PUHY-P350YHA | PUHY-P450YHA | PUHY-P450YHA | |
| Operating conditions | Ambient temperature | Indoor | DB/WB | 27°C/19°C [81°F/66°F] | | | |
| | | Outdoor | | 35°C/ - [95°F/ -] | | | |
| | Indoor unit | No. of connected units | Unit | 8 | | | |
| | | No. of units in operation | | 8 | | | |
| | | Model | | - | 250/250/250/250/100/100/25/25 | | |
| | Piping | Main pipe | m [ft] | 5 [16-3/8] | | | |
| | | Branch pipe | | 10 [32-3/4] | | | |
| | | Total pipe length | | 85 [278-13/16] | | | |
| | Fan speed | | - | Hi | | | |
| | Amount of refrigerant | | kg [lbs-oz] | 52.5 [116] | | | |
| Outdoor unit | Electric current | | A | 74.0 | | | |
| | Voltage | | V | 400 | | | |
| | Compressor frequency | | Hz | 105 | 106 | 106 | |
| LEV opening | Indoor unit | | Pulse | 388/388/388/388/325/325/222/222 | | | |
| | SC (LEV1) | | | 141 | 185 | 185 | |
| | LEV2 | | | 1400 | 1400 | 1400 | |
| Pressure | High pressure (after O/S)/low pressure (before accumulator) | | MPa [psi] | 2.95/0.81 [428/117] | 2.86/0.76 [415/110] | 2.86/0.76 [415/110] | |
| Temp. of each section | Outdoor unit | Discharge (TH4) | °C [°F] | 96 [204] | 95 [202] | 95 [202] | |
| | | Heat exchanger outlet (TH3) | | 47 [117] | 46 [114] | 46 [114] | |
| | | Accumulator inlet | | 7 [45] | 7 [45] | 7 [45] | |
| | | Accumulator outlet | | 7 [45] | 7 [45] | 7 [45] | |
| | | SCC outlet (TH6) | | 25 [77] | 24 [75] | 24 [75] | |
| | | Compressor inlet | | 19 [66] | 19 [66] | 19 [66] | |
| | | Compressor shell bottom | | 56 [132] | 47 [117] | 47 [117] | |
| | Indoor unit | LEV inlet | | 25 [77] | | | |
| | | Heat exchanger outlet | | 4 [40] | | | |

(2) Heating operation

| Operation | | | | Outdoor unit model | | |
|-----------------------|---|-----------------------------|---------------|---------------------------------|----------------------|----------------------|
| | | | | PUHY-P950YSHA | | |
| | | | | PUHY-P250YHA | PUHY-P300YHA | PUHY-P400YHA |
| Operating conditions | Ambient temperature | Indoor | DB/WB | 20°C/ - [68°F/ -] | | |
| | | Outdoor | | 7°C/6°C [45°F/43°F] | | |
| | Indoor unit | No. of connected units | Unit | 8 | | |
| | | No. of units in operation | | 8 | | |
| | | Model | | 250/200/200/125/100/32/32/25 | | |
| | Piping | Main pipe | m [ft] | 5 [16-3/8] | | |
| | | Branch pipe | | 10 [32-3/4] | | |
| | | Total pipe length | | 85 [278-13/16] | | |
| | Fan speed | | - | Hi | | |
| | Amount of refrigerant | | kg [lbs-oz] | 44.5 [98] | | |
| Outdoor unit | Electric current | | A | 48.1 | | |
| | Voltage | | V | 400 | | |
| | Compressor frequency | | Hz | 72 | 90 | 90 |
| LEV opening | Indoor unit | | Pulse | 400/332/332/406/332/254/254/229 | | |
| | SC (LEV1) | | | 0 | | |
| | LEV2 | | | 1400 | 1400 | 1400 |
| Pressure | High pressure (after O/S)/low pressure (before accumulator) | | MPa [psi] | 2.95/0.62 [428/90] | 2.90/0.62 [421/90] | 2.91/0.60 [422/87] |
| Temp. of each section | Outdoor unit | Discharge (TH4) | °C [°F] | 81 [178] | 82 [180] | 89 [192] |
| | | Heat exchanger outlet (TH3) | | -1 [30] | -1 [30] | -2 [28] |
| | | Accumulator inlet | | -3 [26] | -3 [26] | -4 [25] |
| | | Accumulator outlet | | -3 [26] | -3 [26] | -4 [25] |
| | | Compressor inlet | | -3 [26] | -3 [26] | -4 [25] |
| | | Compressor shell bottom | | 30 [86] | 30 [85] | 40 [104] |
| | Indoor unit | LEV inlet | | 39 [102] | | |
| | | Heat exchanger outlet | | 80 [176] | | |

| Operation | | | | Outdoor unit model | | |
|-----------------------|---|-----------------------------|---------------|---------------------------------|-----------------------------|----------------------|
| | | | | PUHY-P1000YSHA | | |
| | | | | PUHY-P300YHA | PUHY-P300YHA | PUHY-P400YHA |
| Operating conditions | Ambient temperature | Indoor | DB/WB | 20°C/ - [68°F/ -] | | |
| | | Outdoor | | 7°C/6°C [45°F/43°F] | | |
| | Indoor unit | No. of connected units | Unit | 8 | | |
| | | No. of units in operation | | 8 | | |
| | | Model | | - | 250/250/200/125/63/63/32/25 | |
| | Piping | Main pipe | m [ft] | 5 [16-3/8] | | |
| | | Branch pipe | | 10 [32-3/4] | | |
| | | Total pipe length | | 85 [278-13/16] | | |
| | Fan speed | | - | Hi | | |
| | Amount of refrigerant | | kg [lbs-oz] | 45 [99] | | |
| Outdoor unit | Electric current | | A | 53.1 | | |
| | Voltage | | V | 400 | | |
| | Compressor frequency | | Hz | 88 | 88 | 88 |
| LEV opening | Indoor unit | | Pulse | 400/400/332/406/455/455/254/229 | | |
| | SC (LEV1) | | | 0 | | |
| | LEV2 | | | 1400 | 1400 | 1400 |
| Pressure | High pressure (after O/S)/low pressure (before accumulator) | | MPa [psi] | 2.90/0.62 [421/90] | 2.90/0.62 [421/90] | 2.91/0.60 [422/87] |
| Temp. of each section | Outdoor unit | Discharge (TH4) | °C [°F] | 82 [180] | 82 [180] | 89 [192] |
| | | Heat exchanger outlet (TH3) | | -1 [30] | -1 [30] | -2 [28] |
| | | Accumulator inlet | | -3 [26] | -3 [26] | -4 [25] |
| | | Accumulator outlet | | -3 [26] | -3 [26] | -4 [25] |
| | | Compressor inlet | | -3 [26] | -3 [26] | -4 [25] |
| | | Compressor shell bottom | | 30 [85] | 30 [85] | 40 [104] |
| | Indoor unit | LEV inlet | | 39 [102] | | |
| | | Heat exchanger outlet | | 80 [176] | | |

| Operation | | | | Outdoor unit model | | |
|-----------------------|---|-----------------------------|---------------|---------------------------------|------------------------------|----------------------|
| | | | | PUHY-P1050YSHA | | |
| | | | | PUHY-P300YHA | PUHY-P350YHA | PUHY-P400YHA |
| Operating conditions | Ambient temperature | Indoor | DB/WB | 20°C/ - [68°F/ -] | | |
| | | Outdoor | | 7°C/6°C [45°F/43°F] | | |
| | Indoor unit | No. of connected units | Unit | 8 | | |
| | | No. of units in operation | | 8 | | |
| | | Model | | - | 250/250/200/125/100/71/32/25 | |
| | Piping | Main pipe | m [ft] | 5 [16-3/8] | | |
| | | Branch pipe | | 10 [32-3/4] | | |
| | | Total pipe length | | 85 [278-13/16] | | |
| | Fan speed | | - | Hi | | |
| | Amount of refrigerant | | kg [lbs-oz] | 47.5 [105] | | |
| Outdoor unit | Electric current | | A | 56.1 | | |
| | Voltage | | V | 400 | | |
| | Compressor frequency | | Hz | 94 | 95 | 95 |
| LEV opening | Indoor unit | | Pulse | 400/400/332/406/332/259/254/229 | | |
| | SC (LEV1) | | | 0 | | |
| | LEV2 | | | 800 | 960 | 1050 |
| Pressure | High pressure (after O/S)/low pressure (before accumulator) | | MPa [psi] | 2.90/0.62 [421/90] | 2.90/0.62 [421/90] | 2.91/0.60 [422/87] |
| Temp. of each section | Outdoor unit | Discharge (TH4) | °C [°F] | 82 [180] | 82 [180] | 89 [192] |
| | | Heat exchanger outlet (TH3) | | -1 [30] | -1 [30] | -2 [28] |
| | | Accumulator inlet | | -3 [26] | -3 [26] | -4 [25] |
| | | Accumulator outlet | | -3 [26] | -3 [26] | -4 [25] |
| | | Compressor inlet | | -3 [26] | -3 [26] | -4 [25] |
| | | Compressor shell bottom | | 30 [85] | 30 [85] | 40 [104] |
| | Indoor unit | LEV inlet | | 39 [102] | | |
| | | Heat exchanger outlet | | 80 [176] | | |

| Operation | | | | Outdoor unit model | | |
|-----------------------|---|-----------------------------|---------------|---------------------------------|------------------------------|----------------------|
| | | | | PUHY-P1100YSHA | | |
| | | | | PUHY-P350YHA | PUHY-P350YHA | PUHY-P400YHA |
| Operating conditions | Ambient temperature | Indoor | DB/WB | 20°C/ - [68°F/ -] | | |
| | | Outdoor | | 7°C/6°C [45°F/43°F] | | |
| | Indoor unit | No. of connected units | Unit | 8 | | |
| | | No. of units in operation | | 8 | | |
| | | Model | | - | 250/250/200/200/100/50/32/25 | |
| | Piping | Main pipe | m [ft] | 5 [16-3/8] | | |
| | | Branch pipe | | 10 [32-3/4] | | |
| | | Total pipe length | | 85 [278-13/16] | | |
| | Fan speed | | - | Hi | | |
| | Amount of refrigerant | | kg [lbs-oz] | 52 [115] | | |
| Outdoor unit | Electric current | | A | 59.2 | | |
| | Voltage | | V | 400 | | |
| | Compressor frequency | | Hz | 101 | 101 | 102 |
| LEV opening | Indoor unit | | Pulse | 400/400/332/332/332/373/254/229 | | |
| | SC (LEV1) | | | 0 | | |
| | LEV2 | | | 960 | 960 | 1050 |
| Pressure | High pressure (after O/S)/low pressure (before accumulator) | | MPa [psi] | 2.90/0.62 [421/90] | 2.90/0.62 [421/90] | 2.91/0.60 [422/87] |
| Temp. of each section | Outdoor unit | Discharge (TH4) | °C [°F] | 82 [180] | 82 [180] | 89 [192] |
| | | Heat exchanger outlet (TH3) | | -1 [30] | -1 [30] | -2 [28] |
| | | Accumulator inlet | | -3 [26] | -3 [26] | -4 [25] |
| | | Accumulator outlet | | -3 [26] | -3 [26] | -4 [25] |
| | | Compressor inlet | | -3 [26] | -3 [26] | -4 [25] |
| | | Compressor shell bottom | | 30 [85] | 30 [85] | 40 [104] |
| | Indoor unit | LEV inlet | | 39 [102] | | |
| | | Heat exchanger outlet | | 80 [176] | | |

| Operation | | | | Outdoor unit model | | |
|-----------------------|---|-----------------------------|---------------|---------------------------------|------------------------------|----------------------|
| | | | | PUHY-P1150YSHA | | |
| | | | | PUHY-P350YHA | PUHY-P350YHA | PUHY-P450YHA |
| Operating conditions | Ambient temperature | Indoor | DB/WB | 20°C/ - [68°F/ -] | | |
| | | Outdoor | | 7°C/6°C [45°F/43°F] | | |
| | Indoor unit | No. of connected units | Unit | 8 | | |
| | | No. of units in operation | | 8 | | |
| | | Model | | - | 250/250/200/200/100/50/32/25 | |
| | Piping | Main pipe | m [ft] | 5 [16-3/8] | | |
| | | Branch pipe | | 10 [32-3/4] | | |
| | | Total pipe length | | 85 [278-13/16] | | |
| | Fan speed | | - | Hi | | |
| | Amount of refrigerant | | kg [lbs-oz] | 52 [115] | | |
| Outdoor unit | Electric current | | A | 62.6 | | |
| | Voltage | | V | 400 | | |
| | Compressor frequency | | Hz | 106 | 105 | 105 |
| LEV opening | Indoor unit | | Pulse | 400/400/332/332/332/373/254/229 | | |
| | SC (LEV1) | | | 0 | | |
| | LEV2 | | | 960 | 960 | 1050 |
| Pressure | High pressure (after O/S)/low pressure (before accumulator) | | MPa [psi] | 2.90/0.62 [421/90] | 2.90/0.62 [421/90] | 2.91/0.60 [422/87] |
| Temp. of each section | Outdoor unit | Discharge (TH4) | °C [°F] | 82 [180] | 82 [180] | 89 [192] |
| | | Heat exchanger outlet (TH3) | | -1 [30] | -1 [30] | -2 [28] |
| | | Accumulator inlet | | -3 [26] | -3 [26] | -4 [25] |
| | | Accumulator outlet | | -3 [26] | -3 [26] | -4 [25] |
| | | Compressor inlet | | -3 [26] | -3 [26] | -4 [25] |
| | | Compressor shell bottom | | 30 [85] | 30 [85] | 40 [104] |
| | Indoor unit | LEV inlet | | 39 [102] | | |
| | | Heat exchanger outlet | | 80 [176] | | |

| Operation | | | | Outdoor unit model | | |
|-----------------------|---|-----------------------------|---------------|---------------------------------|------------------------------|----------------------|
| | | | | PUHY-P1200YSHA | | |
| | | | | PUHY-P350YHA | PUHY-P400YHA | PUHY-P450YHA |
| Operating conditions | Ambient temperature | Indoor | DB/WB | 20°C/ - [68°F/ -] | | |
| | | Outdoor | | 7°C/6°C [45°F/43°F] | | |
| | Indoor unit | No. of connected units | Unit | 8 | | |
| | | No. of units in operation | | 8 | | |
| | | Model | | - | 250/250/250/250/100/50/32/32 | |
| | Piping | Main pipe | m [ft] | 5 [16-3/8] | | |
| | | Branch pipe | | 10 [32-3/4] | | |
| | | Total pipe length | | 85 [278-13/16] | | |
| | Fan speed | | - | Hi | | |
| | Amount of refrigerant | | kg [lbs-oz] | 51.5 [114] | | |
| Outdoor unit | Electric current | | A | 64.3 | | |
| | Voltage | | V | 400 | | |
| | Compressor frequency | | Hz | 106 | 107 | 107 |
| LEV opening | Indoor unit | | Pulse | 400/400/400/400/332/373/254/254 | | |
| | SC (LEV1) | | | 0 | | |
| | LEV2 | | | 960 | 1050 | 1050 |
| Pressure | High pressure (after O/S)/low pressure (before accumulator) | | MPa [psi] | 0.90/0.62 [421/90] | 2.91/0.60 [422/87] | 2.91/0.60 [422/87] |
| Temp. of each section | Outdoor unit | Discharge (TH4) | °C [°F] | 82 [180] | 89 [192] | 89 [192] |
| | | Heat exchanger outlet (TH3) | | -1 [30] | -2 [28] | -2 [28] |
| | | Accumulator inlet | | -3 [26] | -4 [25] | -4 [25] |
| | | Accumulator outlet | | -3 [26] | -4 [25] | -4 [25] |
| | | Compressor inlet | | -3 [26] | -4 [25] | -4 [25] |
| | | Compressor shell bottom | | 30 [85] | 40 [104] | 40 [104] |
| | Indoor unit | LEV inlet | | 39 [102] | | |
| | | Heat exchanger outlet | | 80 [176] | | |

| Operation | | | | Outdoor unit model | | |
|-----------------------|---|-----------------------------|---------------|---------------------------------|-------------------------------|----------------------|
| | | | | PUHY-P1250YSHA | | |
| | | | | PUHY-P350YHA | PUHY-P450YHA | PUHY-P450YHA |
| Operating conditions | Ambient temperature | Indoor | DB/WB | 20°C/ - [68°F/ -] | | |
| | | Outdoor | | 7°C/6°C [45°F/43°F] | | |
| | Indoor unit | No. of connected units | Unit | 8 | | |
| | | No. of units in operation | | 8 | | |
| | | Model | | - | 250/250/250/250/100/100/25/25 | |
| | Piping | Main pipe | m [ft] | 5 [16-3/8] | | |
| | | Branch pipe | | 10 [32-3/4] | | |
| | | Total pipe length | | 85 [278-13/16] | | |
| | Fan speed | | - | Hi | | |
| | Amount of refrigerant | | kg [lbs-oz] | 52.5 [116] | | |
| Outdoor unit | Electric current | | A | 71.7 | | |
| | Voltage | | V | 400 | | |
| | Compressor frequency | | Hz | 111 | 112 | 112 |
| LEV opening | Indoor unit | | Pulse | 400/400/400/400/332/332/229/229 | | |
| | SC (LEV1) | | | 0 | | |
| | LEV2 | | | 960 | 1050 | 1050 |
| Pressure | High pressure (after O/S)/low pressure (before accumulator) | | MPa [psi] | 2.90/0.62 [421/90] | 2.91/0.60 [422/87] | 2.91/0.60 [422/87] |
| Temp. of each section | Outdoor unit | Discharge (TH4) | °C [°F] | 82 [180] | 89 [192] | 89 [192] |
| | | Heat exchanger outlet (TH3) | | -1 [30] | -2 [28] | -2 [28] |
| | | Accumulator inlet | | -3 [26] | -4 [25] | -4 [25] |
| | | Accumulator outlet | | -3 [26] | -4 [25] | -4 [25] |
| | | Compressor inlet | | -3 [26] | -4 [25] | -4 [25] |
| | | Compressor shell bottom | | 30 [85] | 40 [104] | 40 [104] |
| | Indoor unit | LEV inlet | | 39 [102] | | |
| | | Heat exchanger outlet | | 80 [176] | | |

IX Troubleshooting

| | |
|---|-----|
| [1] Error Code Lists | 155 |
| [2] Responding to Error Display on the Remote Controller..... | 158 |
| [3] Investigation of Transmission Wave Shape/Noise..... | 219 |
| [4] Troubleshooting Principal Parts..... | 222 |
| [5] Refrigerant Leak | 242 |
| [6] Compressor Replacement Instructions..... | 244 |
| [7] Troubleshooting Using the Outdoor Unit LED Error Display..... | 246 |



[1] Error Code Lists

| Error Code | Preliminary error code | Error (preliminary) detail code | Error code definition | Searched unit | | | | Notes |
|------------------------|------------------------|---------------------------------|--|--|-------------|---------|-------------------|-------|
| | | | | Outdoor unit | Indoor unit | LOSSNAY | Remote controller | |
| 0403 | 4300 4305 | 01 05 (Note) | Serial communication error | O | | | | |
| 0900 | - | - | Test run | | | O | | |
| 1102 | 1202 | - | Discharge temperature fault | O | | | | |
| 1301 | - | - | Low pressure fault | O | | | | |
| 1302 | 1402 | - | High pressure fault | O | | | | |
| 1500 | 1600 | - | Refrigerant overcharge | O | | | | |
| - | 1605 | - | Preliminary suction pressure fault | O | | | | |
| 2500 | - | - | Drain sensor submergence | | O | | | |
| 2502 | - | - | Drain pump fault | | O | | | |
| 2503 | - | - | Drain sensor (Thd) fault | | O | O | | |
| 2600 | - | - | Water leakage | | | O | | |
| 2601 | - | - | Water supply cutoff | | | O | | |
| 4102 | 4152 | - | Open phase | O | | | | |
| 4106 | - | - | Transmission power supply fault | O | | | | |
| 4115 | - | - | Power supply signal sync error | O | | | | |
| 4116 | - | - | RPM error/Motor error | | O | O | | |
| 4220 4225 (Note) | 4320 4325 (Note) | [108] | Abnormal bus voltage drop | O | | | | |
| | | [109] | Abnormal bus voltage rise | O | | | | |
| | | [111] | Logic error | O | | | | |
| | | [131] | Low bus voltage at startup | O | | | | |
| 4230 | 4330 | - | Heatsink overheat protection | O | | | | |
| 4240 | 4340 | - | Overload protection | O | | | | |
| 4250 4255 (Note) | 4350 4355 (Note) | [101] | IPM error | O | | | | |
| | | [104] | Short-circuited IPM/Ground fault | O | | | | |
| | | [105] | Overcurrent error due to short-circuited motor | O | | | | |
| | | [106] | Instantaneous overcurrent | O | | | | |
| | | [107] | Overcurrent | O | | | | |
| 4260 | - | - | Heatsink overheat protection at startup | O | | | | |
| 5101 | 1202 | - | Temperature sensor fault | Return air temperature (TH21) | | O | | |
| | | | | OA processing unit inlet temperature (TH4) | | | O | |

| Error Code | Preliminary error code | Error (preliminary) detail code | Error code definition | | Searched unit | | | | Notes |
|------------|------------------------|---------------------------------|--|--|---------------|-------------|---------|-------------------|--|
| | | | | | Outdoor unit | Indoor unit | LOSSNAY | Remote controller | |
| 5102 | 1217 | - | Temperature sensor fault | Indoor unit pipe temperature (TH22) | | O | | | |
| | | | | OA processing unit pipe temperature (TH2) | | | O | | |
| | | | | HIC bypass circuit outlet temperature (TH2) | O | | | | |
| 5103 | 1205 | 00 | Temperature sensor fault | Indoor unit gas-side pipe temperature (TH23) | | O | | | |
| | | | | OA processing unit gas-side pipe temperature (TH3) | | | O | | |
| | | | | Pipe temperature at heatexchanger outlet (TH3) | O | | | | |
| 5104 | 1202 | - | Temperature sensor fault | OA processing unit intake air temperature (TH1) | | | O | | |
| | | | | Outside temperature (TH24) | | O | | | Detectable only by the All-Fresh type indoor units |
| | | | | Outdoor unit discharge temperature (TH4) | O | | | | |
| 5105 | 1204 | - | Temperature sensor fault | Accumulator inlet temperature (TH5) | O | | | | |
| 5106 | 1216 | - | Temperature sensor fault | HIC circuit outlet temperature (TH6) | O | | | | |
| 5107 | 1221 | - | Temperature sensor fault | Outside temperature (TH7) | O | | | | |
| 5110 | 1214 | 01 | Temperature sensor fault | Heatsink temperature (THHS) | O | | | | |
| 5201 | - | - | High-pressure sensor fault (63HS1) | | O | | | | |
| 5301 | 4300 | [115] | ACCT sensor fault | | O | | | | |
| | | [117] | ACCT sensor circuit fault | | O | | | | |
| | | [119] | Open-circuited IPM/Loose ACCT connector | | O | | | | |
| | | [120] | Faulty ACCT wiring | | O | | | | |
| 5701 | - | - | Loose float switch connector | | | O | | | |
| 6201 | - | - | Remote controller board fault (nonvolatile memory error) | | | | | O | |
| 6202 | - | - | Remote controller board fault (clock IC error) | | | | | O | |
| 6600 | - | - | Address overlap | | O | O | O | O | |
| 6601 | - | - | Polarity setting error | | O | | | | |
| 6602 | - | - | Transmission processor hardware error | | O | O | O | O | |
| 6603 | - | - | Transmission line bus busy error | | O | O | O | O | |
| 6606 | - | - | Communication error between device and transmission processors | | O | O | O | O | |
| 6607 | - | - | No ACK error | | O | O | O | O | |

| Error Code | Preliminary error code | Error (preliminary) detail code | Error code definition | Searched unit | | | | Notes |
|------------|------------------------|---------------------------------|--|---------------|-------------|---------|-------------------|-------|
| | | | | Outdoor unit | Indoor unit | LOSSNAY | Remote controller | |
| 6608 | - | - | No response error | ○ | ○ | ○ | ○ | |
| 6831 | - | - | MA controller signal reception error (No signal reception) | | ○ | | ○ | |
| 6832 | - | - | MA remote controller signal transmission error (Synchronization error) | | ○ | | ○ | |
| 6833 | - | - | MA remote controller signal transmission error (Hardware error) | | ○ | | ○ | |
| 6834 | - | - | MA controller signal reception error (Start bit detection error) | | ○ | | ○ | |
| 7100 | - | - | Total capacity error | ○ | | | | |
| 7101 | - | - | Capacity code setting error | ○ | ○ | ○ | | |
| 7102 | - | - | Wrong number of connected units | ○ | | | | |
| 7105 | - | - | Address setting error | ○ | | | | |
| 7106 | - | - | Attribute setting error | | | ○ | | |
| 7110 | - | - | Connection information signal transmission/reception error | ○ | | | | |
| 7111 | - | - | Remote controller sensor fault | | ○ | ○ | | |
| 7113 | - | - | Function setting error | ○ | | | | |
| 7117 | - | - | Model setting error | ○ | | | | |
| 7130 | - | - | Incompatible unit combination | ○ | | | | |

Note

The last digit in the check error codes in the 4000's and 5000's and two-digit detail codes indicate if the codes apply to compressor inverter or fan inverter.

Example

Code 4225 (detail code 108): Bus voltage drop in the fan inverter system

Code 4230 : Heatsink overheat protection in the compressor inverter system

| The last digit | Inverter system |
|----------------|----------------------------|
| 0 or 1 | Compressor inverter system |
| 5 | Fan inverter system |

[2] Responding to Error Display on the Remote Controller

1. Error Code

0403

Serial communication error

2. Error definition and error detection method

Serial communication error between the control board and the INV board on the compressor, and between the control board and the Fan board

Detail code 01: Between the control board and the INV board

Detail code 05: Between the control board and the Fan board

3. Cause, check method and remedy

(1) Faulty wiring

Check the following wiring connections.

1) Between Control board and Fan board

| Control board | FAN board |
|---------------|-----------|
| CN2 | CN21 |
| CN4 | CN5 |
| CN332 | CN18V |

2) Between Fan board and INV board

| FAN board | INV board |
|-----------|-------------|
| CN22 | CN2 CN5V |
| CN4 | CN4 |

(2) INV board failure, Fan board failure and Control board failure

Replace the INV board or the Fan board or control board when the power turns on automatically, even if the power source is reset.

Note

Refer to section -6- "Inverter" under part [4] Troubleshooting Principal Parts for error codes related to the inverter.(page 232)

1. Error Code

1102

Discharge temperature fault

2. Error definition and error detection method

- 1) If the discharge temperature of 120 °C [248°F] or more is detected during the above operation (the first detection), the outdoor unit stops once, turns to anti-restart mode for 3 minutes, and restarts after 3 minutes automatically.
- 2) If the discharge temperature of 120° C [248°F] or more is detected again (the second detection) within 30 minutes after the second stop of the outdoor unit described above, the mode will be changed to 3 - minute restart mode, then the outdoor unit will restart in 3 minutes.
- 3) If the discharge temperature of 120°C [248°F] or more is detected (the 30th detection) within 30 minutes after the 29th Stop-page of the outdoor unit described above, the outdoor unit will make an error stop, and the error code "1102" will be displayed.
- 4) If the discharge temperature of 120°C [248°F] or more is detected more than 30 minutes after the previous stop of the outdoor unit, the detection is regarded as the first detection, and the operation described in step 1 above will start.
- 5) For 30 minutes after the stop (the first stop or the second stop) of the outdoor unit, preliminary errors will be displayed on the LED display.

3. Cause, check method and remedy

| Cause | Check method and remedy |
|---|--|
| (1) Gas leak, gas shortage | Refer to the page on refrigerant amount evaluation.(page 109) |
| (2) Overload operation | Check operating conditions and operation status of indoor/ outdoor units. |
| (3) LEV failure on the indoor unit | Perform a cooling or heating operation to check the operation. Cooling: Indoor unit LEV LEV1 LEV2 Heating: Indoor unit LEV LEV2 Refer to the section on troubleshooting the LEV.(page 226) |
| (4) Outdoor unit LEV1 actuation failure Outdoor unit LEV2 actuation failure | |
| (5) Closed refrigerant service valve | Confirm that the refrigerant service valve is fully open. |
| (6) Outdoor fan (including fan parts) failure, motor failure, or fan controller malfunction Rise in discharge temp. by low pressure drawing for (3) - (6). | Check the fan on the outdoor unit. Refer to the section on troubleshooting the outdoor unit fan.(page 225) |
| (7) Gas leak between low and high pressures (4-way valve failure, Compressor failure, Solenoid valve (SV1a) failure) | Perform a cooling or heating operation and check the operation. |
| (8) Thermistor failure (TH4) | Check the thermistor resistor.(page 179) |
| (9) Input circuit failure on the controller board thermistor | Check the inlet air temperature on the LED monitor. |

1. Error Code

| |
|-------------|
| 1301 |
|-------------|

Low pressure fault

2. Error definition and error detection method

When starting the compressor from Stop Mode for the first time if low pressure reads 0.098MPa [14psi] immediately before start-up, the operation immediately stops.

3. Cause, check method and remedy

| Cause | Check method and remedy |
|---|--|
| (1) Inner pressure drop due to a leakage. | Refer to the section on troubleshooting the low pressure sensor.(page 223) |
| (2) Low pressure sensor failure | |
| (3) Short-circuited pressure sensor cable due to torn outer rubber | |
| (4) A pin on the male connector is missing. | |
| (5) Disconnected wire | |
| (6) Failure of the low pressure input circuit on the controller board | |

1. Error Code

1302

High pressure fault 1 (Outdoor unit)

2. Error definition and error detection method

- 1) If the pressure of 3.78MPa [548psi] or higher is detected by the pressure sensor during operation (the first detection), the outdoor stops once, turns to antirestart mode for 3 minutes, and restarts after 3 minutes automatically.
- 2) If the pressure of 3.78MPa [548psi] or higher is detected by the pressure sensor again (the second detection) within 30 minutes after the first stop of the outdoor unit, the outdoor unit stops once, turns to anti-restart mode for 3 minutes, and restarts after 3 minutes automatically.
- 3) If the pressure of 3.87MPa [561psi] or higher is detected by the pressure sensor (the third detection) within 30 minutes of the second stop of the outdoor unit, the outdoor unit will make an error stop, and the error code "1302" will be displayed.
- 4) If the pressure of 3.78MPa [548psi] or higher is detected more than 30 minutes after the stop of the outdoor unit, the detection is regarded as the first detection, and the operation described in step 1 above will start.
- 5) For 30 minutes after the stop of the outdoor unit, preliminary errors will be displayed on the LED display.
- 6) The outdoor unit makes an error stop immediately when not only the pressure sensor but also the pressure switch detects 4.15^{+0,-0.15} MPa [601^{+0,-22} psi]
- 7) Open phase due to unstable power supply voltage may cause the pressure switch to malfunction or cause the units to come to an abnormal stop.

3. Cause, check method and remedy

| | Cause | Check method and remedy |
|------|--|---|
| (1) | Indoor unit LEV2 actuation failure -> Cooling Indoor unit LEV actuation failure -> Heating | Perform a cooling or heating operation to check the operation. Cooling: Indoor unit LEV2 Heating: Indoor unit LEV Refer to the section on troubleshooting the LEV.(page 226) |
| (2) | Closed refrigerant service valve | Confirm that the refrigerant service valve is fully open. |
| (3) | Short cycle on the indoor unit side | Check the indoor units for problems and correct them, if any. |
| (4) | Clogged filter on the indoor unit | |
| (5) | Reduced air flow due to dirty fan on the indoor unit fan | |
| (6) | Dirty heat exchanger of the indoor unit | |
| (7) | Indoor fan (including fan parts) failure or motor failure Rise in high pressure caused by lowered condensing capacity in heating operation for (2) - (7). | Check the outdoor units for problems and correct them, if any. |
| (8) | Short cycle on the outdoor unit | |
| (9) | Dirty heat exchanger of the outdoor unit | Check the fan on the outdoor unit. Refer to the section on troubleshooting the outdoor unit fan.(page 225) |
| (10) | Outdoor fan (including fan parts) failure, motor failure, or fan controller malfunction Rise in discharge temp. by low pressure drawing for (8) - (10). | |
| (11) | Solenoid valve (SV1a) malfunction (The by-pass valve (SV1a) can not control rise in high pressure). | Refer to the section on troubleshooting the solenoid valve.(page 224) |
| (12) | Thermistor failure (TH3, TH7) | Check the thermistor resistor.(page 179) |
| (13) | Pressure sensor failure | Refer to the page on the troubleshooting of the high pressure sensor. (page 222) |
| (14) | Failure of the thermistor input circuit and pressure sensor input circuit on the controller board | Check the temperature and the pressure of the sensor with LED monitor. |
| (15) | Thermistor mounting problem (TH3, TH7) | Check the temperature and the pressure of the sensor with LED monitor. |
| (16) | Disconnected male connector on the pressure switch (63H1) or disconnected wire | |
| (17) | Voltage drop caused by unstable power supply voltage | Check the input voltage at the power supply terminal block (TB1). |

1. Error Code

1302

High pressure fault 2 (Outdoor unit)

2. Error definition and error detection method

If the pressure of 0.098MPa [14psi] or lower is registered on the pressure sensor immediately before start-up, it will trigger an abnormal stop, and error code "1302" will be displayed.

3. Cause, check method and remedy

| | Cause | Check method and remedy |
|-----|--|---|
| (1) | Inner pressure drop due to a leakage. | Refer to the page on the troubleshooting of the high pressure sensor.(page 222) |
| (2) | Pressure sensor failure | |
| (3) | Shorted-circuited pressure sensor cable due to torn outer rubber | |
| (4) | A pin on the male connector on the pressure sensor is missing or contact failure | |
| (5) | Disconnected pressure sensor cable | |
| (6) | Failure of the pressure sensor input circuit on the controller board | |

1. Error Code

1500

Refrigerant overcharge

2. Error definition and error detection method

An error can be detected by the discharge temperature superheat.

- 1) If the formula " $TdSH \leq 10^{\circ}C [18^{\circ}F]$ " is satisfied during operation (first detection), the outdoor unit stops, goes into the 3-minute restart mode, and starts up in three minutes.
- 2) If the formula " $TdSH \leq 10^{\circ}C [18^{\circ}F]$ " is satisfied again within 30 minutes of the fifth stoppage of the outdoor unit (sixth detection), the unit comes to an abnormal stop, and the error code "1500" appears.
- 3) If the formula " $TdSH \leq 10^{\circ}C [18^{\circ}F]$ " is satisfied 30 minutes or more after the first stoppage of the outdoor unit, the same sequence as Item "1 above (first detection) is followed.
- 4) For 30 minutes after the stop of the outdoor unit, preliminary errors will be displayed on the LED display.

3. Cause, check method and remedy

| | Cause | Check method and remedy |
|-----|---|--|
| (1) | Overcharged refrigerant | Refer to the page on refrigerant amount evaluation.(page 109) |
| (2) | Thermistor input circuit failure on the control board | Check the temperature and pressure readings on the sensor that are displayed on the LED monitor. |
| (3) | Faulty mounting of thermistor (TH4) | Check the temperature and pressure readings on the thermistor that are displayed on the LED monitor. |
| (4) | Outdoor unit LEV2a, b actuation failure -> Heating | Refer to the section on troubleshooting the LEV. (page 226) |

1. Error Code

| |
|-------------|
| 2500 |
|-------------|

Drain sensor submergence (Models with a drain sensor)

2. Error definition and error detection method

- 1) If an immersion of the drain sensor in the water is detected while the unit is in any mode other than the Cool/Dry mode and when the drain pump goes from OFF to ON, this condition is considered preliminary water leakage. While this error is being detected, humidifier output cannot be turned on. (Applicable to the units manufactured in or after October 2006)
- 2) If the immersion of the sensor in the water is detected four consecutive times at an hour interval, this is considered water leakage, and "2500" appears on the monitor.
- 3) Detection of water leakage is also performed while the unit is stopped.
- 4) Preliminary water leakage is cancelled when the following conditions are met:
 - One hour after the preliminary water leakage was detected, it is not detected that the drain pump goes from OFF to ON.
 - The operation mode is changed to Cool/Dry.
 - The liquid pipe temperature minus the inlet temperature is -10°C [-18°F] or less.

3. Cause, check method and remedy

| Cause | Check method and remedy |
|--|---|
| (1) Drain water drainage problem • Clogged drain pump • Clogged drain piping • Backflow of drain water from other units | Check for proper drainage. |
| (2) Adhesion of water drops to the drain sensor • Trickling of water along the lead wire • Rippling of drain water caused by filter clogging | 1) Check for proper lead wire installation. 2) Check for clogged filter. |
| (3) Failure of the relay circuit for the solenoid valve | Replace the relay. |
| (4) Indoor unit control board failure • Drain sensor circuit failure | If the above item checks out OK, replace the indoor unit control board. |

1. Error Code

2500

Drain sensor submergence (Models with a float switch)

2. Error definition and error detection method

- 1) If an immersion of the float switch in the water is detected while the unit is in any mode other than the Cool/Dry mode and when the drain pump goes from OFF to ON, this condition is considered preliminary water leakage. While this error is being detected, humidifier output cannot be turned on.
- 2) If the drain pump turns on within one hour after preliminary water leakage is detected and the above-mentioned condition is detected two consecutive times, water leakage error water leakage is detected, and "2500" appears on the monitor.
- 3) Detection of water leakage is also performed while the unit is stopped.
- 4) Preliminary water leakage is cancelled when the following conditions are met:
 - One hour after the preliminary water leakage was detected, it is not detected that the drain pump goes from OFF to ON.
 - The operation mode is changed to Cool/Dry.
 - The liquid pipe temperature minus the inlet temperature is - 10°C [-18°F] or less.

3. Cause, check method and remedy

| Cause | Check method and remedy |
|---|--|
| (1) Drain water drainage problem •Clogged drain pump •Clogged drain piping •Backflow of drain water from other units | Check for proper drainage. |
| (2) Stuck float switch Check for slime in the moving parts of the float switch. | Check for normal operation of the float switch. |
| (3) Float switch failure | Check the resistance with the float switch turned on and turned off. |

<Reference>

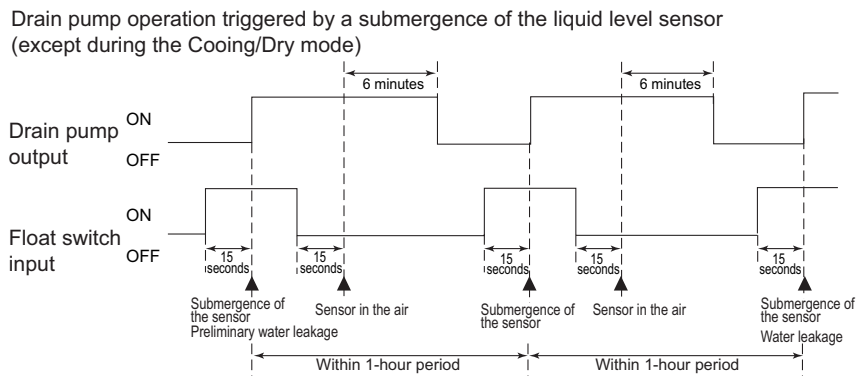

1. Error Code

2502

Drain pump fault (Models with a drain sensor)

2. Error definition and error detection method

- 1) Make the drain sensor thermistor self-heat. If the temperature rise is small, it is interpreted that the sensor is immersed in water. This condition is considered to be a preliminary error, and the unit goes into the 3-minute restart delay mode.
- 2) If another episode of the above condition is detected during the preliminary error, this is considered a drain pump error, and "2502" appears on the monitor.
- 3) This error is always detected while the drain pump is in operation.
- 4) The following criteria are met when the criteria for the forced stoppage of outdoor unit (system stoppage) are met.
 - *"Liquid pipe temperature - inlet temperature \leq -10°C [-18 °F] " has been detected for 30 minutes.
 - *The immersion of drain sensor is detected 10 consecutive times.
 - *The conditions that are listed under items 1) through 3) above are always met before the criteria for the forced stoppage of the outdoor unit.
- 5) The indoor unit that detected the conditions that are listed in item 4) above brings the outdoor unit in the same refrigerant circuit to an error stop (compressor operation prohibited), and the outdoor unit brings all the indoor units in the same refrigerant circuit that are in any mode other than Fan or Stop to an error stop. "2502" appears on the monitor of the units that came to an error stop.
- 6) Forced stoppage of the outdoor unit
 Detection timing: The error is detected whether the unit is in operation or stopped.
- 7) Ending criteria for the forced stoppage of outdoor unit
 Power reset the indoor unit that was identified as the error source and the outdoor unit that is connected to the same refrigerant circuit.
 Forced stoppage of the outdoor unit cannot be cancelled by stopping the unit via the remote controller.
 (Note) Items 1) - 3) and 4) - 7) are detected independently from each other.

Note

The address and attribute that appear on the remote controller are those of the indoor unit (or OA processing unit) that caused the error.

3. Cause, check method and remedy

| Cause | Check method and remedy |
|--|---|
| (1) Drain pump failure | Check for proper functioning of the drain pump. |
| (2) Drain water drainage problem •Clogged drain pump •Clogged drain piping | Check for proper drainage. |
| (3) Adhesion of water drops to the drain sensor •Trickling of water along the lead wire •Rippling of drain water caused by filter clogging | 1) Check for proper lead wire installation. 2) Check for clogged filter. |
| (4) Indoor unit control board failure •Drain pump drive circuit failure •Drain heater output circuit failure | If the above item checks out OK, replace the indoor unit control board. |
| (5) Items (1) through (4) above and an indoor unit electronic valve closure failure (leaky valve) occurred simultaneously. | Check the solenoid valves on the indoor unit for leaks. |

1. Error Code

2502

Drain pump fault (Models with a float switch)

2. Error definition and error detection method

- 1) The immersion of sensor tip in water is detected by the ON/OFF signal from the float switch.
 - *Submergence of the sensor
When it is detected that the float switch has been ON for 15 seconds, it is interpreted that the sensor tip is immersed in water.
 - *Sensor in the air
When it is detected that the float switch has been OFF for 15 seconds, it is interpreted that the sensor tip is not immersed in water.
- 2) If it is detected that the float switch has been ON for 3 minutes after the immersion of the sensor tip was detected, this is considered a drain pump failure, and "2502" appears on the monitor.
 - *The total time it takes for this error to be detected is 3 minutes and 15 seconds, including the time it takes for the first immersion of the sensor tip to be detected.
- 3) Detection of drain pump failure is performed while the unit is stopped.
- 4) The following criteria are met when the criteria for the forced stoppage of outdoor unit (system stoppage) are met.
 - *"Liquid pipe temperature - inlet temperature $\leq -10^{\circ}\text{C}$ [-18°F]" has been detected for 30 minutes.
 - *It is detected by the float switch that the sensor tip has been immersed in water for 15 minutes or more.
 - *The conditions that are listed under items 1) through 3) above are always met before the criteria for the forced stoppage of the outdoor unit.
- 5) The indoor unit that detected the conditions that are listed in item 4) above brings the outdoor unit in the same refrigerant circuit to an error stop (compressor operation prohibited), and the outdoor unit brings all the indoor units in the same refrigerant circuit that are in any mode other than Fan or Stop to an error stop.
- 6) Forced stoppage of the outdoor unit
Detection timing: The error is detected whether the unit is in operation or stopped.
This error is detected whether the unit is in operation or stopped.
- 7) Ending criteria for the forced stoppage of outdoor unit
Power reset the indoor unit that was identified as the error source and the outdoor unit that is connected to the same refrigerant circuit.
Forced stoppage of the outdoor unit cannot be cancelled by stopping the unit via the remote controller.
(Note) Items 1) - 3) and 4) - 7) are detected independently from each other.

Note

The address and attribute that appear on the remote controller are those of the indoor unit (or OA processing unit) that caused the error.

3. Cause, check method and remedy

| Cause | Check method and remedy |
|--|--|
| (1) Drain pump failure | Check for proper functioning of the drain pump mechanism |
| (2) Drain water drainage problem •Clogged drain pump •Clogged drain piping | Check for proper drainage. |
| (3) Stuck float switch Check for slime in the moving parts of the float switch. | Check for normal operation of the float switch. |
| (4) Float switch failure | Check the resistance with the float switch turned on and turned off. |
| (5) Indoor unit control board failure •Drain pump drive circuit failure •Float switch input circuit failure | Replace indoor unit control board. |
| (6) Items (1) through (5) above and an indoor unit electronic valve closure failure (leaky valve) occurred simultaneously. | Check the solenoid valves on the indoor unit for leaks. |

1. Error Code

2503

Drain sensor (Thd) fault

2. Error definition and error detection method

- If the open or short circuit of the thermistor has been detected for 30 seconds, this condition is considered to be a preliminary error, and the unit goes into the 3-minute restart delay mode.
- If another episode of the above condition is detected during the preliminary error, this is considered a drain sensor error.(If the short or open circuit of the thermistor is no longer detected, normal operation will be restored in 3 minutes.)
- This error is detected when one of the following conditions are met.
 - *During Cool/Dry operation
 - *Liquid pipe temperature minus inlet temperature is equal to or smaller than - 10°C [-18°F] (except during the defrost cycle)
 - *When the liquid temperature thermistor or suction temperature thermistor or short or open circuited.
 - *Drain pump is in operation.
 - *One hour has elapsed since the drain sensor went off.
 - Short: 90°C [194 °F] or above
 - Open: - 20°C [-4 °F] or below

3. Cause, check method and remedy

| Cause | Check method and remedy |
|---|--|
| (1) Faulty connector (CN31) insertion. | 1) Check for connector connection failure. Reinsert the connector, restart the operation, and check for proper operation. |
| (2) Broken or semi-broken thermistor wire | 2) Check for a broken thermistor wire. |
| (3) Thermistor failure | 3) Check the resistance of the thermistor. 0°C[32 °F]:6.0kΩ 10°C[50 °F]:3.9kΩ 20°C[68°F]:2.6kΩ 30°C[86°F]:1.8kΩ 40°C[104 °F]:1.3kΩ |
| (4) Indoor unit control board (error detection circuit) failure | 4) Replace the indoor unit control board if the problem recurs when the unit is operated with the No.-1 and No.-2 pins on the drain sensor connector (CN31) being short-circuited. If the above item checks out OK, there are no problems with the drain sensor. Turn off the power and turn it back on. |

1. Error Code

2600

Water leakage

2. Cause, check method and remedy

Check that water does not leak from the pipes in such as the humidifier.

1. Error Code

2601

Water supply cutoff

2. Cause, check method and remedy

| Cause | | Check method and remedy |
|-------|---|---|
| (1) | The water tank of the humidifier is empty. | Check the amount of supply water. Check for the solenoid valve and for the connection. |
| (2) | The solenoid valve for humidification is OFF. | Check the connector. |
| (3) | Disconnected float switch | Check the connecting part. |
| (4) | Poor operation of float switch | Check for the float switch. |
| (5) | Frozen water tank | Turn off the power source of the water tank to defrost, and turn it on again. |

1. Error Code

4102

Open phase

2. Error definition and error detection method

- An open phase of the power supply (L1 phase, N phase) was detected at power on.
- The L3 phase current is outside of the specified range.

Note

The open phase of the power supply may not always be detected if a power voltage from another circuit is applied.

3. Cause, check method and remedy

| | Cause | Check method and remedy |
|-----|---|---|
| (1) | Power supply problem •Open phase voltage of the power supply •Power supply voltage drop | Check the input voltage to the power supply terminal block TB1. |
| (2) | Noise filter problem •Coil problem •Circuit board failure | <ul style="list-style-type: none"> •Check the coil connections. •Check for coil burnout. •Confirm that the voltage at the CN3 connector is 198 V or above. |
| (3) | Wiring failure | <p>Confirm that the voltage at the control board connector CNAC is 198 V or above.</p> <p>If the voltage is below 198V, check the wiring connection between the noise filter board CN3, noise filter board CN2 and control board CNAC.</p> <p>Confirm that the wiring between noise filter TB23 and INV board SC-L3 is put through CT3.</p> |
| (4) | Blown fuse | <p>Check for a blown fuse (F01) on the control board.</p> <p>->If a blown fuse is found, check for a short-circuiting or earth fault of the actuator.</p> |
| (5) | CT3 failure | Replace the inverter if this problem is detected after the compressor has gone into operation. |
| (6) | Control board failure | Replace the control board if none of the above is causing the problem. |

1. Error Code

4106

<Transmission power supply fault Error detail code FF (Outdoor unit)>

2. Error definition and error detection method

Transmission power output failure

3. Cause

- 1) Wiring failure
- 2) Transmission power supply cannot output voltage because overcurrent was detected.
- 3) Voltage cannot be output due to transmission power supply problem.
- 4) Transmission voltage detection circuit failure

4. Check method and remedy

Check the items in IX [4] -7- (2) Troubleshooting transmission power circuit of outdoor unit on all outdoor units in the same refrigerant circuit.(page 241)

<Transmission power supply fault other than error detail code FF (Outdoor unit)>

2. Error definition and error detection method

Transmission power reception failure

3. Cause

One of the outdoor units stopped supplying power, but no other outdoor units start supplying power.

4. Check method and remedy

Check the items in IX [4] -7- (2) Troubleshooting transmission power circuit of outdoor unit on all outdoor units in the same refrigerant circuit.(page 241)

1. Error Code

4115

Power supply signal sync error

2. Error definition and error detection method

The frequency cannot be determined when the power is switched on.

3. Cause, check method and remedy

| Cause | | Check method and remedy |
|-------|--|--|
| (1) | Power supply error | Check the voltage of the power supply terminal block (TB1). |
| (2) | Noise filter problem •Coil problem •Circuit board failure | •Check the coil connections. •Check for coil burnout. •Confirm that the voltage at the CN3 connector is 198 V or above. |
| (3) | Faulty wiring | Check fuse F01 on the control board. |
| (4) | Wiring failure Between noise filter CN3 and noise filter CN2 and control board CNAC | Confirm that the voltage at the control board connector CNAC is 198 V or above. |
| (5) | Control board failure | If none of the items described above is applicable, and if the trouble reappears even after the power is switched on again, replace the control board. |

1. Error Code

4116

RPM error/Motor error

2. Error definition and error detection method

•LOSSNAY

- *The motor keep running even if the power is OFF.
- *The thermal overload relay is ON. (Only for the three-phase model)

•Indoor unit

If detected less than 180rpm or more than 2000rpm, the indoor unit will restart and keep running for 3 minutes.If detected again, the display will appear.

3. Cause, check method and remedy

| Cause | | Check method and remedy |
|-------|-----------------------------|--|
| (1) | Board failure | Replace the board. |
| (2) | Motor malfunction | Check for the motor and the solenoid switch. |
| (3) | Solenoid switch malfunction | |

1. Error Code

| |
|-------------|
| 4220 |
| 4225 |

Abnormal bus voltage drop (Detail code 108)

2. Error definition and error detection method

If Vdc 289V or less is detected during Inverter operation. (S/W detection)

3. Cause, check method and remedy

(1) Power supply environment

Check whether the unit makes an instantaneous stop when the detection result is abnormal or a power failure occurs.
Check whether the power voltage (Between L1 and L2, L2 and L3, and L1 and L3) is 342V or less across all phases.

(2) Voltage drop detected

4220

•Check the voltage between the FT-P and FT-N terminals on the INV board while the inverter is stopped and if it is 420 V or above, check the following items.

- 1) Confirm on the LED monitor that the bus voltage is above 289V.

Replace the INV board if it is below 289 V.

- 2) Check the voltage at CN72 on the control board. ->Go to (3).
- 3) Check the noise filter coil connections and for coil burnout.
- 4) Check the wiring connections between the following sections
Between the noise filter board and INV board. Between the INV board and DCL.
Replace 72C if no problems are found.

- 5) Check the IGBT module resistance on the INV board (Refer to the Trouble shooting for IGBT module).

•Check the voltage between the FT-P and FT-N terminals on the INV board while the inverter is stopped and if it is less than 420 V, check the following items.

- 1) Check the coil connections and for coil burnout on the noise filter.
- 2) Check the wiring between the noise filter board and INV board.
- 3) Check the connection to SCP1 and SC-P2 on the INV board.
- 4) Check the in-rush current resistor value.
- 5) Check the 72C resistance value.
- 6) Check the DCL resistance value.

Replace the INV board if no problems are found.

4225

•Check the voltage at CNVDC on the Fan board while the inverter is stopped and if it is 420 V or above, check the following items.

- 1) Check the voltage at CN72 on the control board. ->Go to 3).
- 2) Check the noise filter coil connections and for coil burnout.
- 3) Check the wiring connections between the following sections
Between the INV board and the Fan board.
- 4) Check contents 4220

Replace the Fan board if no problems are found.

•Check the voltage at CNVDC on the Fan board while the inverter is stopped and if it is less than 420 V, check the following items.

- 1) Check the state of the wiring connections between the INV board and the Fan board.
- 2) Check contents 4220

Replace the Fan board if no problems are found.

(3) Control board failure

Confirm that DC12V is applied to the connector CN72 on the control board while the inverter is operating. If not, replace the control board.

Note

Refer to section -6- "Inverter" under part [4] Troubleshooting Principal Parts for error codes related to the inverter.(page 232)

1. Error Code

| |
|------------------------------------|
| <p>4220 4225</p> |
|------------------------------------|

Abnormal bus voltage rise (Detail code 109)

2. Error definition and error detection method

If Vdc ≥ 830V is detected during inverter operation.

3. Cause, check method and remedy

(1) Different voltage connection

Check the power supply voltage on the power supply terminal block (TB1).

(2) INV board failure

If the problem recurs, replace the INV board.

In the case of 4220: INV board

In the case of 4225: Fan board

Note

Refer to section -6- "Inverter" under part [4] Troubleshooting Principal Parts for error codes related to the inverter.(page 232)

1. Error Code

| |
|------------------------------------|
| <p>4220 4225</p> |
|------------------------------------|

Logic error (Detail code 111)

2. Error definition and error detection method

H/W error

If only the H/W error logic circuit operates, and no identifiable error is detected.

3. Cause, Check method and remedy

In the case of 4220

| Cause | Check method and remedy |
|-----------------------|--|
| (1) External noise | |
| (2) INV board failure | Refer to IX [4] -6- (2) [1].(page 234) |

In the case of 4225

| Cause | Check method and remedy |
|-----------------------|--|
| (1) External noise | |
| (2) Fan board failure | Refer to IX [4] -6- (2) [6].(page 236) |

Note

Refer to section -6- "Inverter" under part [4] Troubleshooting Principal Parts for error codes related to the inverter.(page 232)

1. Error Code

| |
|----------------------------|
| 4220 4225 |
|----------------------------|

Low bus voltage at startup (Detail code 131)

2. Error definition and error detection method

When $V_{dc} \leq 160$ V is detected just before the inverter operation.

3. Cause, check method and remedy

(1) Inverter main circuit failure

Same as detail code 108 of 4220 error

Note

Refer to section -6- "Inverter" under part [4] Troubleshooting Principal Parts for error codes related to the inverter.(page 232)

1. Error Code

| |
|-------------|
| 4230 |
|-------------|

Heatsink overheat protection

2. Error definition and error detection method

When the heat sink temperature (THHS) remains at or above 105°C [221°F] is detected.

3. Cause, check method and remedy

| Cause | Check method and remedy |
|------------------------------|---|
| (1) Fan board failure | Refer to IX [4] -6- (2) [6].(page 236) |
| (2) Outdoor unit fan failure | Check the outdoor unit fan operation. If any problem is found with the fan operation, check the fan motor. ->Refer to IX [4] -6- (2) [5].(page 235) |
| (3) Air passage blockage | Check that the heat sink cooling air passage is not blocked |
| (4) THHS failure | 1) Check for proper installation of the INV board IGBT. (Check for proper installation of the IGBT heatsink.) 2) Check the THHS sensor reading on the LED monitor. ->If an abnormal value appears, replace the INV board. |

Note

Refer to section -6- "Inverter" under part [4] Troubleshooting Principal Parts for error codes related to the inverter.(page 232)

1. Error Code

4240

Overload protection

2. Error definition and error detection method

If the output current of "(Iac) > I_{max} (Arms)" or "THHS > 100°C [212°F]" is continuously detected for 10 minutes or more during inverter operation.

| Model | I _{max} (Arms) |
|-------------|-------------------------|
| P200, P250 | 19 |
| P300 - P450 | 27 |

3. Cause, check method and remedy

| Cause | Check method and remedy |
|------------------------------|--|
| (1) Air passage blockage | Check that the heat sink cooling air passage is not blocked |
| (2) Power supply environment | Power supply voltage is 342 V or above. |
| (3) Inverter failure | Refer to IX [4] -6-.(page 232) |
| (4) Compressor failure | Check that the compressor has not overheated during operation. -> Check the refrigerant circuit (oil return section). Refer to IX [4] -6- (2) [2].(page 234) |

Note

Refer to section -6- "Inverter" under part [4] Troubleshooting Principal Parts for error codes related to the inverter.(page 232)

1. Error Code

4250
4255

IPM error (Detail code 101)

2. Error definition and error detection method

In the case of 4250

Overcurrent is detected by the overcurrent detection resistor (RSH) on the INV board.

In the case of 4255

IPM error signal is detected.

3. Cause, check method and remedy

In the case of 4250

| Cause | Check method and remedy |
|-----------------------------|---|
| (1) Inverter output related | Refer to IX [4] -6- (2) [1] - [4].(page 234) Check the IGBT module resistance value of the INV board, if no problems are found. (Refer to the Trouble shooting for IGBT module) |

In the case of 4255

| Cause | Check method and remedy |
|---------------------------|--|
| (1) Fan motor abnormality | Refer to IX [4] -6- (2) [5].(page 235) |
| (2) Fan board failure | Refer to IX [4] -6- (2) [6].(page 236) |

Note

Refer to section -6- "Inverter" under part [4] Troubleshooting Principal Parts for error codes related to the inverter.(page 232)

1. Error Code

4250

**Instantaneous overcurrent (Detail code 106)
Overcurrent (Detail code 107)**

2. Error definition and error detection method

P200 and P250 models
Overcurrent 94 Apeak or 22 Arms and above is detected by the current sensor.
P300 - P450 models
Overcurrent 94 Apeak or 35 Arms and above is detected by the current sensor.

3. Cause, check method and remedy

| Cause | Check method and remedy |
|-----------------------------|---|
| (1) Inverter output related | Refer to IX [4] -6- (2) [1] - [4].(page 234) Check the IGBT module resistance value of the INV board, if no problems are found. (Refer to the Trouble shooting for IGBT module) |

Note

Refer to section -6- "Inverter" under part [4] Troubleshooting Principal Parts for error codes related to the inverter.(page 232)

1. Error Code

**4250
4255**

Short-circuited IPM/Ground fault (Detail code 104)

2. Error definition and error detection method

When IPM/IGBT short damage or grounding on the load side is detected just before starting the inverter.

3. Cause, check method and remedy

In the case of 4250

| Cause | Check method and remedy |
|--------------------------------|--|
| (1) Grounding fault compressor | Refer to IX [4] -6- (2) [2].(page 234) |
| (2) Inverter output related | Refer to IX [4] -6- (2) [1] - [4].(page 234) |

In the case of 4255

| Cause | Check method and remedy |
|----------------------------------|--|
| (1) Grounding fault of fan motor | Refer to IX [4] -6- (2) [5].(page 235) |
| (2) Fan board failure | Refer to IX [4] -6- (2) [6].(page 236) |

Note

Refer to section -6- "Inverter" under part [4] Troubleshooting Principal Parts for error codes related to the inverter.(page 232)

1. Error Code

4250
4255

Overcurrent error due to short-circuited motor (Detail code 105)

2. Error definition and error detection method

When a short is detected on the load side just before starting the inverter operation.

3. Cause, Check method and remedy

In the case of 4250

| Cause | Check method and remedy |
|----------------------------------|--|
| (1) Short - circuited compressor | Refer to IX [4] -6- (2) [2].(page 234) |
| (2) Output wiring | Check for a short circuit. |

In the case of 4255

| Cause | Check method and remedy |
|---------------------------------|--|
| (1) Short - circuited fan motor | Refer to IX [4] -6- (2) [5].(page 235) |
| (2) Output wiring | Check for a short circuit. |

Note

Refer to section -6- "Inverter" under part [4] Troubleshooting Principal Parts for error codes related to the inverter.(page 232)

1. Error Code

4260

Heatsink overheat protection at startup

2. Error definition and error detection method

The heatsink temperature (THHS) remains at or above 105°C [221°F] for 10 minutes or more at inverter startup.

3. Cause, check method and remedy

Same as 4230 error

1. Error Code

5101

Return air temperature sensor (TH21) fault (Indoor unit)
Return air temperature sensor (TH4) fault (OA processing unit)

5102

Pipe temperature sensor (TH22) fault (Indoor unit)
Pipe temperature sensor (TH2) fault (OA processing unit)

5103

Gas-side pipe temperature sensor (TH23) fault (Indoor unit)
Gas-side pipe temperature sensor (TH3) fault (OA processing unit)

5104

Intake air temperature sensor (TH1) fault (OA processing unit)
Intake air temperature sensor (TH24) fault (All-fresh (100% outdoor air) type indoor unit)

2. Error definition and error detection method

•If a short or an open is detected during thermostat ON, the outdoor unit turns to anti-restart mode for 3 minutes. When the error is not restored after 3 minutes (if restored, the outdoor unit runs normally), the outdoor unit makes an error stop.

Short: detectable at 90°C [194°F] or higher

Open: detectable at -40°C [-40°F] or lower

•Sensor error at gas-side cannot be detected under the following conditions.

*During heating operation

*During cooling operation for 3 minutes after the compressor turns on.

3. Cause, check method and remedy

| Cause | | Check method and remedy |
|-------|---|--|
| (1) | Thermistor failure | Check the thermistor resistor. 0°C [32°F]: 15 kohm 10°C [50°F]: 9.7 kohm 20°C [68°F]: 6.4 kohm 30°C [86°F]: 4.3 kohm 40°C [104°F]: 3.1 kohm |
| (2) | Connector contact failure | |
| (3) | Disconnected wire or partial disconnected thermistor wire | |
| (4) | Unattached thermistor or contact failure | |
| (5) | Indoor board (detection circuit) failure | |
| | | Check the connector contact. When no fault is found, the indoor board is a failure. |

1. Error Code

5102

HIC bypass circuit outlet temperature sensor (TH2) fault (Outdoor unit)

5103

Heat exchanger outlet temperature sensor (TH3) fault (Outdoor unit)

5104

Discharge temperature sensor (TH4) fault (Outdoor unit)

5105

Accumulator inlet temperature sensor (TH5) fault (Outdoor unit)

5106

HIC circuit outlet temperature sensor (TH6) fault (Outdoor unit)

5107

Outside temperature sensor (TH7) fault (Outdoor unit)

2. Error definition and error detection method

- When a short (high temperature intake) or an open (low temperature intake) of the thermistor is detected (the first detection), the outdoor unit stops, turns to anti-restart mode for 3 minutes, and restarts when the detected temperature of the thermistor.
- When a short or an open is detected again (the second detection) after the first restart of the outdoor unit, the outdoor unit stops, turns to anti-restart mode for 3 minutes, and restarts in 3 minutes when the detected temperature is within the normal range.
- When a short or an open is detected again (the third detection) after the previous restart of the outdoor unit, the outdoor unit makes an error stop.
- When a short or an open of the thermistor is detected just before the restart of the outdoor unit, the outdoor unit makes an error stop, and the error code "5102", "5103", "5104", "5105", "5106" or "5107" will appear.
- During 3-minute antirestart mode, preliminary errors will be displayed on the LED display.
- A short or an open described above is not detected for 10 minutes after the compressor start, during defrost mode, or for 3 minutes after defrost mode.

3. Cause, check method and remedy

| Cause | Check method and remedy |
|---|---|
| (1) Thermistor failure | Check thermistor resistance. |
| (2) Pinched lead wire | Check for pinched lead wire. |
| (3) Torn wire coating | Check for wire coating. |
| (4) A pin on the male connector is missing or contact failure | Check connector. |
| (5) Disconnected wire | Check for wire. |
| (6) Thermistor input circuit failure on the control board | Check the intake temperature of the sensor with the LED monitor. When the temperature is far different from the actual temperature, replace the control board. |

<Reference>

| | Short detection | Open detection |
|-----|--------------------------------------|-------------------------------------|
| TH2 | 70 °C [158 °F] and above (0.4 k Ω) | -40 °C [-40 °F] and below (130 k Ω) |
| TH3 | 110 °C [230 °F] and above (0.4 k Ω) | -40 °C [-40 °F] and below (130 k Ω) |
| TH4 | 240 °C [464 °F] and above (0.57 k Ω) | 0 °C [32 °F] and below (698 k Ω) |
| TH5 | 70 °C [158 °F] and above (0.4 k Ω) | -40 °C [-40 °F] and below (130 k Ω) |
| TH6 | 70 °C [158 °F] and above (1.14 k Ω) | -40 °C [-40 °F] and below (130 k Ω) |
| TH7 | 110 °C [230 °F] and above (0.4 k Ω) | -40 °C [-40 °F] and below (130 k Ω) |

1. Error Code

5110

Heatsink temperature sensor (THHS) fault (Detail code 01)

2. Error definition and error detection method

When a short or an open of THHS is detected just before or during the inverter operation.

3. Cause, check method and remedy

| Cause | Check method and remedy |
|-----------------------|---|
| (1) INV board failure | If the problem recurs when the unit is put into operation, replace the INV board. |

Note

Refer to section -6- "Inverter" under part [4] Troubleshooting Principal Parts for error codes related to the inverter.(page 232)

1. Error Code

5201

High-pressure sensor fault (63HS1)

2. Error definition and error detection method

- If the high pressure sensor detects 0.098MPa [14psi] or less during the operation, the outdoor unit stops once, turns to anti-restart mode for 3 minutes, and restarts after 3 minutes when the detected high pressure sensor is 0.098MPa [14psi] or more.
- If the high pressure sensor detects 0.098MPa [14psi] or less just before the restart, the outdoor unit makes an error stop, and the error code "5201" will appear.
- During 3-minute antirestart mode, preliminary errors will be displayed on the LED display.
- A error is not detected for 3 minutes after the compressor start, during defrost operation, or 3 minutes after defrost operation.

3. Cause, check method and remedy

| Cause | Check method and remedy |
|---|--|
| (1) High pressure sensor failure | Refer to the page on the troubleshooting of the high pressure sensor. (IX [4] -1- (page 222)) |
| (2) Pressure drop due to refrigerant leak | |
| (3) Torn wire coating | |
| (4) A pin on the male connector is missing or contact failure | |
| (5) Disconnected wire | |
| (6) High pressure sensor input circuit failure on the control board | |

1. Error Code

5301

ACCT sensor fault (Detail code 115)

2. Error definition and error detection method

When the formula "output current < 1.5 Arms" remains satisfied for 10 seconds while the inverter is in operation.

3. Cause, check method and remedy

| Cause | Check method and remedy |
|--------------------------------|--|
| (1) Inverter open output phase | Check the output wiring connections. |
| (2) Compressor failure | Refer to IX [4] -6- (2) [2].(page 234) |
| (3) INV board failure | Refer to IX [4] -6- (2) [1],[3],[4].(page 234) |

Note

Refer to section -6-"Inverter" under part [4] Troubleshooting Principal Parts for error codes related to the inverter.(page 232)

1. Error Code

5301

ACCT sensor circuit fault (Detail code 117)

2. Error definition and error detection method

When an error value is detected with the ACCT detection circuit just before the inverter starts

3. Cause, check method and remedy

| Cause | Check method and remedy |
|------------------------|--|
| (1) INV board failure | Refer to IX [4] -6- (2) [1],[3],[4].(page 234) |
| (2) Compressor failure | Refer to IX [4] -6- (2) [2].(page 234) |

Note

Refer to section -6-"Inverter" under part [4] Troubleshooting Principal Parts for error codes related to the inverter.(page 232)

1. Error Code

5301

Open-circuited IPM/Loose ACCT connector (Detail code 119)

2. Error definition and error detection method

Presence of enough current cannot be detected during the self-diagnostic operation immediately before inverter startup.

3. Cause, check method and remedy

| Cause | Check method and remedy |
|------------------------------------|--|
| (1) Inverter output wiring problem | Check output wiring connections. Confirm that the U- and W-phase output cables are put through CT12 and CT22 on the INV board respectively. |
| (2) Inverter failure | Refer to IX [4] -6- (2) [3], [4].(page 235) |
| (3) Compressor failure | Refer to IX [4] -6- (2) [2].(page 234) |

Note

Refer to section -6- "Inverter" under part [4] Troubleshooting Principal Parts for error codes related to the inverter.(page 232)

1. Error Code

5301

Faulty ACCT wiring (Detail code 120)

2. Error definition and error detection method

Presence of target current cannot be detected during the self-diagnostic operation immediately before startup. (Detection of improperly mounted ACCT sensor)

3. Cause, check method and remedy

| Cause | Check method and remedy |
|------------------------------------|--|
| (1) Inverter output wiring problem | Check output wiring connections. Confirm that the U- and W-phase output cables are put through CT12 and CT22 on the INV board respectively. |
| (2) Inverter failure | Refer to IX [4] -6- (2) [3], [4].(page 235) |
| (3) Compressor failure | Refer to IX [4] -6- (2) [2].(page 234) |

Note

Refer to section -6- "Inverter" under part [4] Troubleshooting Principal Parts for error codes related to the inverter.(page 232)

1. Error Code

5701

Loose float switch connector

2. Error definition and error detection method

Detection of the disconnected float switch (open-phase condition) during operation

3. Cause, check method and remedy

(1) CN4F disconnection or contact failure

Check for disconnection of the connector (CN4F) on the indoor unit control board.

1. Error Code

6201

Remote controller board fault (nonvolatile memory error)

2. Error definition and error detection method

This error is detected when the data cannot be read out from the built-in nonvolatile memory on the remote controller.

3. Cause, check method and remedy

(1) Remote controller failure

Replace the remote controller.

1. Error Code

6202

Remote controller board fault (clock IC error)

2. Error definition and error detection method

This error is detected when the built-in clock on the remote controller is not properly functioning.

3. Cause, check method and remedy

(1) Remote controller failure

Replace the remote controller.

1. Error Code

6600

Address overlap

2. Error definition and error detection method

An error in which signals from more than one indoor units with the same address are received

Note

The address and attribute that appear on the remote controller indicate the controller that detected the error.

3. Cause, check method and remedy

| Cause | Check method and remedy |
|---|---|
| Two or more of the following have the same address: Outdoor units, indoor units, LOSSNAY units, controllers such as ME remote controllers. <Example> 6600 "01" appears on the remote controller Unit #01 detected the error. Two or more units in the system have 01 as their address. | Find the unit that has the same address as that of the error source. Once the unit is found, correct the address. Then, turn off the outdoor units, indoor units, and LOSSNAY units, keep them all turned off for at least five minutes, and turn them back on. |

1. Error Code

6601

Polarity setting error

2. Error definition and error detection method

The error detected when transmission processor cannot distinguish the polarities of the M-NET transmission line.

3. Cause, check method and remedy

| Cause | Check method and remedy |
|---|---|
| (1) No voltage is applied to the M-NET transmission line that G(B)-50A is connected to. | Check if power is supplied to the M-NET transmission line of the G(B)-50A, and correct any problem found. |
| (2) M-NET transmission line to which G(B)-50A is connected is short-circuited. | |

1. Error Code

6602

Transmission processor hardware error

2. Error definition and error detection method

Although "0" was surely transmitted by the transmission processor, "1" is displayed on the transmission line.

Note

The address/attribute appeared on the display on the remote controller indicates the controller where an error occurred.

3. Cause

- 1) When the wiring work of or the polarity of either the indoor or outdoor transmission line is performed or is changed while the power is on, the transmitted data will collide, the wave shape will be changed, and an error will be detected.
- 2) Grounding fault of the transmission line
- 3) When grouping the indoor units that are connected to different outdoor units, the male power supply connectors on the multiple outdoor units are connected to the female power supply switch connector (CN40).
- 4) When the power supply unit for transmission lines is used in the system connected with MELANS, the male power supply connector is connected to the female power supply switch connector (CN40) on the outdoor unit.
- 5) Controller failure of the source of the error
- 6) When the transmission data is changed due to the noise on the transmission line
- 7) Voltage is not applied on the transmission line for centralized control (in case of grouped indoor units connected to different outdoor units or in case of the system connected with MELANS)

4. Check method and remedy

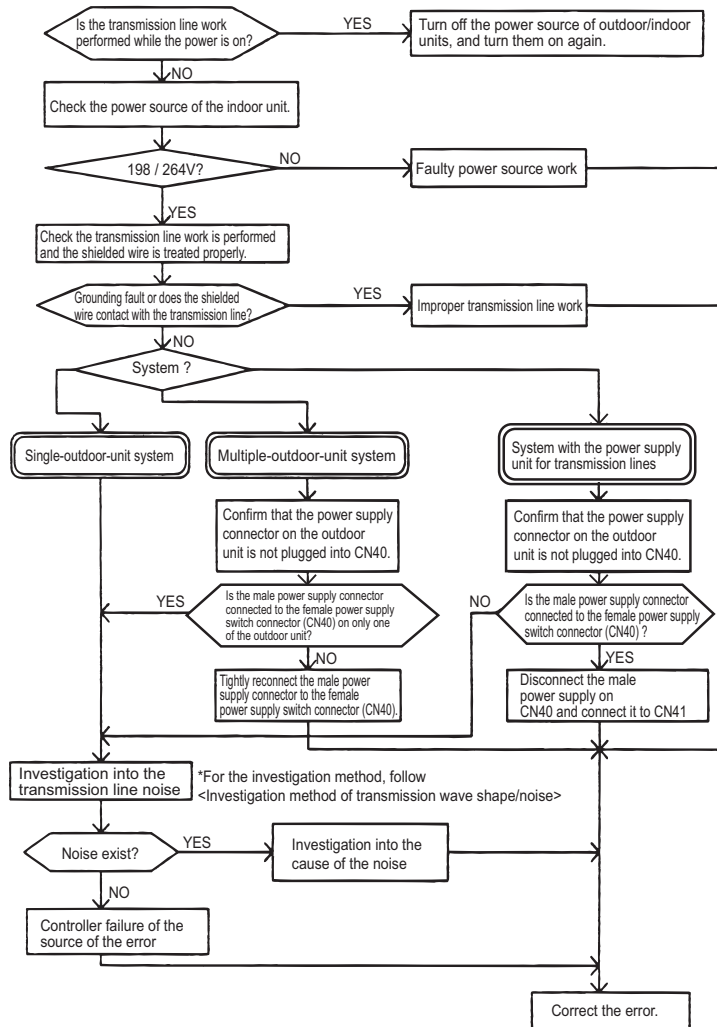

1. Error Code

6603

Transmission line bus busy error

2. Error definition and error detection method

- Generated error when the command cannot be transmitted for 4-10 minutes in a row due to bus-busy
- Generated error when the command cannot be transmitted to the transmission line for 4-10 minutes in a row due to noise

Note

The address/attribute appeared on the display on the remote controller indicates the controller where an error occurred.

3. Cause, check method and remedy

| | Cause | Check method and remedy |
|-----|--|---|
| (1) | The transmission processor cannot be transmitted as the short-wavelength voltage like noise exists consecutively on the transmission line. | No noise indicates that the error source controller is a failure. If noise exists, investigate the noise. -> No noise indicates that the error source controller is a failure. -> If noise exists, investigate the noise. |
| (2) | Error source controller failure | |

1. Error Code

6606

Communication error between device and transmission processors

2. Error definition and error detection method

Communication error between the main microcomputer on the indoor unit board and the microcomputer for transmission

Note

The address/attribute appeared on the display on the remote controller indicates the controller where an error occurred.

3. Cause, check method and remedy

| | Cause | Check method and remedy |
|-----|---|---|
| (1) | Data is not properly transmitted due to accidental erroneous operation of the controller of the error source. | Turn off the power source of the outdoor and the indoor units.(When the power source is turned off separately, the microcomputer will not be reset, and the error will not be corrected.) -> If the same error occurs, the error source controller is a failure. |
| (2) | Error source controller failure | |

1. Error Code

6607

No ACK error

2. Error definition and error detection method

The error is detected when no acknowledgement (ACK signal) is received after the transmission. (eg. When the data is transmitted six times in a row with 30 seconds interval, the error is detected on the transmission side.)

Note

The address/attribute appeared on the display on the remote controller indicates the controller which did not provide the response (ACK).

3. System configuration

(1) System with one outdoor unit

| Error source address | Error display | Detection method | Cause | Check method and remedy |
|---------------------------|--|---|--|--|
| Outdoor unit (OC) | ME remote controller (RC) MA remote controller (MA) | No acknowledgement (ACK) at IC transmission to OC | (1) Contact failure of transmission line of OC or IC (2) Decrease of transmission line voltage/signal by exceeding acceptable range of transmission wiring. Farthest:200 m [656ft] or less Remote controller wiring: 10m [32ft] or less (3) Erroneous sizing of transmission line (Not within the range below). Wire diameter: 1.25mm ² [AWG16] or more (4) Indoor unit control board failure | Turn off the power source of the outdoor unit, and turn it on again. If the error is accidental, it will run normally. If not, check the causes (1) - (4). |
| Indoor unit (IC) | ME remote controller (RC) MA remote controller (MA) | No acknowledgement (ACK) at RC transmission to IC | (1) When IC unit address is changed or modified during operation. (2) Faulty or disconnected IC transmission wiring (3) Disconnected IC connector (CN2M) (4) Indoor unit controller failure (5) ME remote controller failure | Turn off the outdoor/indoor units for 5 or more minutes, and turn them on again. If the error is accidental, they will run normally. If not, check the causes (1) - (5). |
| LOSSNAY (LC) | ME remote controller (RC) MA remote controller (MA) | No acknowledgement (ACK) at IC transmission to LC | (1) The power source of LOSSNAY has been shut off. (2) When the address of LOSSNAY is changed in the middle of the operation (3) Faulty or disconnected transmission wiring of LOSSNAY (4) Disconnected connector (CN1) on LOSSNAY (5) Controller failure of LOSSNAY | Turn off the power source of LOSSNAY and turn it on again. If the error is accidental, it will run normally. If not, check the causes (1) - (5). |
| ME remote controller (RC) | ME remote controller (RC) MA remote controller (MA) | No acknowledgement (ACK) at IC transmission to RC | (1) Faulty transmission wiring at IC unit side. (2) Faulty wiring of the transmission line for ME remote controller (3) When the address of ME remote controller is changed in the middle of the operation (4) ME remote controller failure | Turn off the power source of the outdoor unit for 5 minutes or more, and turn it on again. If the error is accidental, it will run normally. If not, check the causes (1) - (4). |

1. Error Code

6607

No ACK error

2. Error definition and error detection method

The error is detected when no acknowledgement (ACK signal) is received after the transmission. (eg. When the data is transmitted six times in a row with 30 seconds interval, the error is detected on the transmission side.)

Note

The address/attribute appeared on the display on the remote controller indicates the controller which did not provide the response (ACK).

3. System configuration

(2) Grouping of units in a system with multiple outdoor units

| Error source address | Error display | Detection method | Cause | Check method and remedy |
|----------------------|--|---|--|---|
| Outdoor unit (OC) | ME remote controller (RC) MA remote controller (MA) | No acknowledgement (ACK) at IC transmission to OC | Same cause as that for system with one outdoor unit | Same remedy as that for system with one outdoor unit |
| Indoor unit (IC) | ME remote controller (RC) MA remote controller (MA) | No acknowledgement (ACK) at RC transmission to IC | (1) Same causes as (1) - (5) for system with one outdoor unit (2) Disconnection or short circuit of the transmission line for the outdoor unit on the terminal block for centralized control line connection (TB7) (3) When multiple outdoor units are connected and the power source of one of the outdoor units has been shut off. (4) The male power supply connector of the outdoor unit is not connected to the female power supply switch connector (CN40). (5) The male power supply connectors on 2 or more outdoor units are connected to the female power supply switch connector (CN40) for centralized control. If an error occurs, after the unit runs normally once, the following causes may be considered. <ul style="list-style-type: none"> ♦Total capacity error (7100) ♦Capacity code error (7101) ♦Error in the number of connected units (7102) ♦Address setting error (7105) | 1) Turn off the power sources of the outdoor and indoor units for 5 or more minutes, and turn them on again. If the error is accidental, the will run normally. If not, check the cause 2). 2) Check the causes of (1) - (5). If the cause is found, correct it. If no cause is found, check 3). 3) Check the LED displays for troubleshooting on other remote controllers whether an error occurs. If an error is found, -> If an error is found, check the check code definition, and correct the error. If no error is found, -> Indoor unit board failure |

1. Error Code

6607

No ACK error

2. Error definition and error detection method

The error is detected when no acknowledgement (ACK signal) is received after the transmission. (eg. When the data is transmitted six times in a row with 30 seconds interval, the error is detected on the transmission side.)

Note

The address/attribute appeared on the display on the remote controller indicates the controller which did not provide the response (ACK).

3. System configuration

(2) Grouping of units in a system with multiple outdoor units

| Error source address | Error display | Detection method | Cause | Check method and remedy |
|----------------------|--|---|---|--|
| LOSS-NAY (LC) | ME remote controller (RC) MA remote controller (MA) | No acknowledgement (ACK) at IC transmission to LC | <p>(1) Factors (1) through (5) in the "Factors in system with one outdoor unit" (When performing an interlocked operation of the LOSSNAY unit and the indoor units that are connected to different outdoor units.)</p> <p>(2) Disconnection or short circuit of the transmission line for the outdoor unit on the terminal block for centralized control line connection (TB7)</p> <p>(3) When multiple outdoor units are connected and the power source of one of the outdoor units has been shut off.</p> <p>(4) The male power supply connector of the outdoor unit is not connected to the female power supply switch connector (CN40).</p> <p>(5) The male power supply connectors on 2 or more outdoor units are connected to the female power supply switch connector (CN40) for centralized control.</p> <p>If an error occurs, after the unit runs normally once, the following causes may be considered.</p> <ul style="list-style-type: none"> ◆Total capacity error (7100) ◆Capacity code error (7101) ◆Error in the number of connected units (7102) ◆Address setting error (7105) | <p>1) Turn off the power source of LOSSNAY for 5 or more minutes, and turn it on again. If the error is accidental, it will run normally. If not, check the cause 2).</p> <p>2) Check the causes of (1) - (5). If the cause is found, correct it. If no cause is found, check 3).</p> <p>3) Same cause as that for indoor unit described in 3)</p> |

1. Error Code

6607

No ACK error

2. Error definition and error detection method

The error is detected when no acknowledgement (ACK signal) is received after the transmission. (eg. When the data is transmitted six times in a row with 30 seconds interval, the error is detected on the transmission side.)

Note

The address/attribute appeared on the display on the remote controller indicates the controller which did not provide the response (ACK).

3. System configuration

(2) Grouping of units in a system with multiple outdoor units

| Error source address | Error display | Detection method | Cause | Check method and remedy |
|---------------------------|--|---|---|---|
| ME remote controller (RC) | ME remote controller (RC) MA remote controller (MA) | No acknowledgement (ACK) at IC transmission to RC | (1) Same causes as (1) - (4) for system with one outdoor unit (2) Disconnection or short circuit of the transmission line for the outdoor unit on the terminal block for centralized control line connection (TB7) (3) When multiple outdoor units are connected and the power source of one of the outdoor units has been shut off. (4) The male power supply connector of the outdoor unit is not connected to the female power supply switch connector (CN40). (5) The male power supply connectors on 2 or more outdoor units are connected to the female power supply switch connector (CN40) for centralized control. If the problem recurs after normal operation is restored, the problem is caused by one of the following factors: ♦Total capacity error (7100) ♦Capacity code setting error (7101) ♦Error in the number of connected units (7102) ♦Address setting error (7105) | 1) Turn off the power source of LOSSNAY for 5 or more minutes, and turn it on again. If the error is accidental, it will run normally. If not, check the cause 2). 2) Check the causes of (1) - (5). If the cause is found, correct it. If no cause is found, check 3). 3) Same cause as that for indoor unit described in 3) |

1. Error Code

6607

No ACK error

2. Error definition and error detection method

The error is detected when no acknowledgement (ACK signal) is received after the transmission. (eg. When the data is transmitted six times in a row with 30 seconds interval, the error is detected on the transmission side.)

Note

The address/attribute appeared on the display on the remote controller indicates the controller which did not provide the response (ACK).

3. System configuration

(3) System connected to the system controllers (MELANS)

| Error source address | Error display | Detection method | Cause | Check method and remedy |
|--|---|---|---|--|
| Outdoor unit (OC) | ME remote controller (RC) System controller (SC) MA remote controller (MA) | No acknowledgement (ACK) at IC transmission to OC | Same cause as that for system with one outdoor unit | Same remedy as that for system with one outdoor unit |
| Indoor unit (IC) | ME remote controller (RC) MA remote controller (MA) | No acknowledgement (ACK) at RC transmission to IC | Same as grouping of units in a system with multiple outdoor units | Same remedy as that for grouping of units in a system with multiple outdoor units |
| | System controller (SC) | No acknowledgement (ACK) at SC transmission to IC | 1. Error occurrence on some IC (1) Same cause as that for system with one outdoor unit | Same remedy as that for system with one outdoor unit |
| | | | 2. Error occurrence on all IC in the system with one outdoor unit (1) Total capacity error (7100) (2) Capacity code error (7101) (3) Error in the number of connected units (7102) (4) Address setting error (7105) (5) Disconnection or short circuit of the transmission line for the outdoor unit on the terminal block for centralized control line connection (TB7) (6) Turn off the power source of the outdoor unit (7) Malfunction of electrical system for the outdoor unit | 1) Check the LED display for troubleshooting on the outdoor unit. •If an error is found, check the check code definition, and correct the error. •If no error is found, check 2). 2) Check (5) - (7) on the left. |
| 3. Error occurrence on all IC (1) Same causes as (1) - (7) described in 2. (2) The male power supply connectors on 2 or more outdoor units are connected to the female power supply switch connector (CN40) for the transmission line for centralized control. (3) Disconnection or shutdown of the power source of the power supply unit for transmission line (4) System controller (MELANS) malfunction | Check voltage of the transmission line for centralized control. •20V or more: Check (1) and (2) on the left. •Less than 20V: Check (3) on the left. | | | |

1. Error Code

6607

No ACK error

2. Error definition and error detection method

The error is detected when no acknowledgement (ACK signal) is received after the transmission. (eg. When the data is transmitted six times in a row with 30 seconds interval, the error is detected on the transmission side.)

Note

The address/attribute appeared on the display on the remote controller indicates the controller which did not provide the response (ACK).

3. System configuration

(3) System connected to the system controllers (MELANS)

| Error source address | Error display | Detection method | Cause | Check method and remedy |
|---------------------------|--|--|---|--|
| ME remote controller (RC) | ME remote controller (RC) System controller (SC) MA remote controller (MA) | No acknowledgement (ACK) at IC transmission to RC | Same as grouping of units in a system with multiple outdoor units | Same remedy as that for grouping of units in a system with multiple outdoor units |
| | System controller (SC) | No acknowledgement (ACK) at MELANS transmission to RC | 1. Error occurrence on some IC (1) Same cause as that for system with one outdoor unit | Same remedy as that for system with one outdoor unit |
| | | | 2. Error occurrence on all IC in the system with one outdoor unit (1) An error is found by the outdoor unit. Total capacity error (7100) Capacity code error (7101) Error in the number of connected units (7102) Address setting error (7105) (2) Disconnection or short circuit of the transmission line for the outdoor unit on the terminal block for centralized control line connection (TB7) (3) Turn off the power source of the outdoor unit (4) Malfunction of electrical system for the outdoor unit | 1) Check the LED display for troubleshooting on the outdoor unit. ♦ If an error is found, check the check code definition, and correct the error. ♦ If no error is found, check the cause 2). 2) Check (2) - (4) on the left. |
| | | 3. Error occurrence on all IC (1) Same causes as (1) - (4) described in 2. (2) When the power supply unit for transmission lines is used and the male power supply connector is connected to the female power supply switch connector (CN40) for the transmission line for centralized control (3) Disconnection or shutdown of the power source of the power supply unit for transmission line (4) System controller (MELANS) malfunction | Check (1) - (4) on the left. | |

1. Error Code

6607

No ACK error

2. Error definition and error detection method

The error is detected when no acknowledgement (ACK signal) is received after the transmission. (eg. When the data is transmitted six times in a row with 30 seconds interval, the error is detected on the transmission side.)

Note

The address/attribute appeared on the display on the remote controller indicates the controller which did not provide the response (ACK).

3. System configuration

(3) System connected to the system controllers (MELANS)

| Error source address | Error display | Detection method | Cause | Check method and remedy |
|--|---------------|---|---|---|
| System controller (SC) ME remote controller (RC) MA remote controller (MA) | | No acknowledgement (ACK) at IC transmission to SC | 1. Error display on some displays on ME remote controllers (1) Faulty wiring of the transmission line for ME remote controller (2) Disconnection or contact failure of the transmission connector for ME remote controller (3) ME remote controller failure | Check (1) - (3) on the left. |
| | | | 2. Error occurrence on all IC in the system with one outdoor unit (1) An error is found by the outdoor unit. Total capacity error (7100) Capacity code error (7101) Error in the number of connected units (7102) Address setting error (7105) (2) Disconnection or short circuit of the transmission line for the outdoor unit on the terminal block for centralized control line connection (TB7) (3) Turn off the power source of the outdoor unit (4) Malfunction of electrical system for the outdoor unit | 1) Check the LED display for troubleshooting on the outdoor unit. ♦ If an error is found, check the check code definition, and correct the error. ♦ If no error is found, check the cause 2) 2) Check (2) - (4) on the left. |
| | | | 3. Error display on all displays on ME remote controllers (1) Same causes as (1) - (4) described in 2. (2) When the power supply unit for transmission lines is used and the male power supply connector is connected to the female power supply switch connector (CN40) for the transmission line for centralized control (3) Disconnection or shutdown of the power source of the power supply unit for transmission line (4) System controller (MELANS) malfunction | Check (1) - (4) on the left |

1. Error Code

6607

No ACK error

2. Error definition and error detection method

The error is detected when no acknowledgement (ACK signal) is received after the transmission. (eg. When the data is transmitted six times in a row with 30 seconds interval, the error is detected on the transmission side.)

Note

The address/attribute appeared on the display on the remote controller indicates the controller which did not provide the response (ACK).

3. System configuration

(4) Errors that are not limited to a particular system

| Error source address | Error display | Detection method | Cause | Check method and remedy |
|-------------------------------------|---------------|------------------|--|---|
| Address which should not be existed | - | - | <p>(1) Although the address of ME remote controller has been changed after the group is set using ME remote controller, the indoor unit is keeping the memory of the previous address. The same symptom will appear for the registration with SC.</p> <p>(2) Although the address of LOSSNAY has been changed after the interlock registration of LOSSNAY is made using ME remote controller, the indoor unit is keeping the memory of the previous address.</p> | <p>Delete unnecessary information of non-existing address which some indoor units have. Use either of the following two methods for deletion.</p> <p>1) Address deletion by ME remote controller Delete unnecessary address information using the manual setting function of ME remote controller. Refer to this service handbook "IV [2] Group Settings and Interlock Settings via the ME Remote Controller 1. (3) Address deletion".</p> <p>2) Deletion of connection information of the outdoor unit by the deleting switch</p> <p>Note that this switch deletes all the group information set via ME remote controller and all the interlock information of LOSSNAY and the indoor unit.</p> <ul style="list-style-type: none"> ♦ Turn off the power source of the outdoor unit, and wait for 5 minutes. ♦ Turn on the dip switch (SW2-2) on the outdoor unit control board. ♦ Turn on the power source of the outdoor unit, and wait for 5 minutes. ♦ Turn off the power source of the outdoor unit, and wait for 5 minutes. ♦ Turn off the dip switch (SW2-2) on the outdoor unit control board. ♦ Turn on the power source of the outdoor unit. |

1. Error Code

6608

No response error

2. Error definition and error detection method

- When no response command is returned although acknowledgement (ACK) is received after transmission, an error is detected.
- When the data is transmitted 10 times in a row with 3 seconds interval, an error is detected on the transmission side.

Note

The address/attribute appeared on the display on the remote controller indicates the controller where an error occurred.

3. Cause

- 1) The transmission line work is performed while the power is on, the transmitted data will collide, and the wave shape will be changed.
- 2) The transmission is sent and received repeatedly due to noise.
- 3) Decrease of transmission line voltage/signal by exceeding acceptable range of transmission wiring.
Farthest:200m [656ft] or less
Remote controller wiring:12m [39ft] or less
- 4) The transmission line voltage/signal is decreased due to erroneous sizing of transmission line.
Wire diameter: 1.25mm²[AWG16] or more

4. Check method and remedy

- 1) When an error occurs during commissioning, turn off the power sources for the outdoor unit, indoor unit, and LOSSNAY for 5 or more minutes, and then turn them on again.
 - When they return to normal operation, the cause of the error is the transmission line work performed with the power on.
 - If an error occurs again, check the cause 2).
- 2) Check 3) and 4) above.
 - If the cause is found, correct it.
 - If no cause is found, check 3).
- 3) Check transmission wave shape/ noise on trans-mission line by following "IX [3] Investigation of Transmission Wave Shape/ Noise".(page 219).

Noise is the most possible cause of the error "6608".

1. Error Code

6831

MA controller signal reception error (No signal reception)

2. Error definition and error detection method

- Communication between the MA remote controller and the indoor unit is not done properly.
- No proper data has been received for 3 minutes.

3. Cause

- 1) Contact failure of the remote controller lines of MA remote controller or the indoor unit.
- 2) All the remote controllers are set to SUB.
- 3) Failure to meet wiring regulations
 - Wire length
 - Wire size
 - Number of remote controllers
 - Number of indoor units
- 4) The remote controller is removed after the installation without turning the power source off.
- 5) Noise interference on the remote controller transmission lines
- 6) Faulty circuit that is on the indoor board and performs transmission/ reception of the signal from the remote controller
- 7) Problems with the circuit on the remote controller that sends or receives the signals from the remote controller

4. Check method and remedy

- 1) Check for disconnected or loose transmission lines for the indoor units or MA remote controllers.
- 2) Confirm that the power is supplied to the main power source and the remote controller line.
- 3) Confirm that MA remote controller's capacity limit is not exceeded.
- 4) Check the sub/main setting of the MA remote controllers. One of them must be set to MAIN.
- 5) Diagnose the remote controller (described in the remote controller installation manual).
[OK]: no problems with the remote controller (check the wiring regulations)
[NG]: Replace the MA remote controller.
[6832, 6833, ERC]: Due to noise interference <Go to 6>
- 6) Check wave shape/noise on MA remote controller line by following "IX [3] Investigation of Transmission Wave Shape/ Noise".(page 219)
- 7) When no problems are found with items 1) through 6), replace the indoor unit board or the MA remote controller.
The following status can be confirmed on LED1 and 2 on the indoor unit board.
 - If LED1 is lit, the main power source of the indoor unit is turned on.
 - If LED2 is lit, the MA remote controller line is being powered.

1. Error Code

6832

MA remote controller signal transmission error (Synchronization error)

2. Error definition and error detection method

- MA remote controller and the indoor unit is not done properly.
- Failure to detect opening in the transmission path and unable to send signals
 - *Indoor unit : 3 minutes
 - *Remote controller : 6 seconds

3. Cause

- 1) Contact failure of the remote controller lines of MA remote controller or the indoor unit
- 2) 2 or more remote controllers are set to MAIN
- 3) Overlapped indoor unit address
- 4) Noise interference on the remote controller lines
- 5) Failure to meet wiring regulations
 - Wire length
 - Wire size
 - Number of remote controllers
 - Number of indoor units
- 6) Problems with the circuit on the remote controller that sends or receives the signals from the remote controller

4. Check method and remedy

- 1) Check for disconnected or loose transmission lines for the indoor units or MA remote controllers.
- 2) Confirm that the power is supplied to the main power source and the remote controller line.
- 3) Confirm that MA remote controller's capacity limit is not exceeded.
- 4) Check the sub/main setting of the MA remote controllers. One of them must be set to MAIN.
- 5) Diagnose the remote controller (described in the remote controller installation manual).
[OK]: no problems with the remote controller (check the wiring regulations)
[NG]: Replace the MA remote controller.
[6832, 6833, ERC]: Due to noise interference <Go to 6>
- 6) Check wave shape/noise on MA remote controller line by following "IX [3] Investigation of Transmission Wave Shape/ Noise".(page 219)
- 7) When no problems are found with items 1) through 6), replace the indoor unit board or the MA remote controller.
The following status can be confirmed on LED1 and 2 on the indoor unit board.
 - If LED1 is lit, the main power source of the indoor unit is turned on.
 - If LED2 is lit, the MA remote controller line is being powered.

1. Error Code

6833

MA remote controller signal transmission error (Hardware error)

2. Error definition and error detection method

- Communication between the MA remote controller and the indoor unit is not done properly.
- An error occurs when the transmitted data and the received data differ for 30 times in a row.

3. Cause

- 1) Contact failure of the remote controller lines of MA remote controller or the indoor unit
- 2) 2 or more remote controllers are set to MAIN
- 3) Overlapped indoor unit address
- 4) Noise interference on the remote controller lines
- 5) Failure to meet wiring regulations
 - Wire length
 - Wire size
 - Number of remote controllers
 - Number of indoor units
- 6) Problems with the circuit on the remote controller that sends or receives the signals from the remote controller

4. Check method and remedy

- 1) Check for disconnected or loose transmission lines for the indoor units or MA remote controllers.
- 2) Confirm that the power is supplied to the main power source and the remote controller line.
- 3) Confirm that MA remote controller's capacity limit is not exceeded.
- 4) Check the sub/main setting of the MA remote controllers. One of them must be set to MAIN.
- 5) Diagnose the remote controller (described in the remote controller installation manual).
[OK]: no problems with the remote controller (check the wiring regulations)
[NG]: Replace the MA remote controller.
[6832, 6833, ERC]: Due to noise interference <Go to 6>
- 6) Check wave shape/noise on MA remote controller line by following "IX [3] Investigation of Transmission Wave Shape/ Noise".(page 219)
- 7) When no problems are found with items 1) through 6), replace the indoor unit board or the MA remote controller.
The following status can be confirmed on LED1 and 2 on the indoor unit board.
 - If LED1 is lit, the main power source of the indoor unit is turned on.
 - If LED2 is lit, the MA remote controller line is being powered.

1. Error Code

6834

MA controller signal reception error (Start bit detection error)

2. Error definition and error detection method

- Communication between the MA remote controller and the indoor unit is not done properly.
- No proper data has been received for 2 minutes.

3. Cause

- 1) Contact failure of the remote controller lines of MA remote controller or the indoor unit.
- 2) All the remote controllers are set to SUB.
- 3) Failure to meet wiring regulations
 - Wire length
 - Wire size
 - Number of remote controllers
 - Number of indoor units
- 4) The remote controller is removed after the installation without turning the power source off.
- 5) Noise interference on the remote controller transmission lines
- 6) Faulty circuit that is on the indoor board and performs transmission/ reception of the signal from the remote controller
- 7) Problems with the circuit on the remote controller that sends or receives the signals from the remote controller

4. Check method and remedy

- 1) Check for disconnected or loose transmission lines for the indoor units or MA remote controllers.
- 2) Confirm that the power is supplied to the main power source and the remote controller line.
- 3) Confirm that MA remote controller's capacity limit is not exceeded.
- 4) Check the sub/main setting of the MA remote controllers. One of them must be set to MAIN.
- 5) Diagnose the remote controller (described in the remote controller installation manual).
 - [OK]: no problems with the remote controller (check the wiring regulations)
 - [NG]: Replace the MA remote controller.
 - [6832, 6833, ERC]: Due to noise interference <Go to 6>
- 6) Check wave shape/noise on MA remote controller line by following "IX [3] Investigation of Transmission Wave Shape/ Noise".(page 219)
- 7) When no problems are found with items 1) through 6), replace the indoor unit board or the MA remote controller.
 - The following status can be confirmed on LED1 and 2 on the indoor unit board.
 - If LED1 is lit, the main power source of the indoor unit is turned on
 - If LED2 is lit, the MA remote controller line is being powered.

1. Error Code

7100

Total capacity error

2. Error definition and error detection method

The model total of indoor units in the system with one outdoor unit exceeds limitations.

3. Error source, cause, check method and remedy,

| Error source | Cause | Check method and remedy | | | | | | | | | | | | | | | | | | | | | | | | | | | | | | | | | | | | | | | | | | | | | | |
|--------------|--|---|----------------|-----------|-----|-----------|-----|-----------|-----|-----------|-----------|-----------|-----|-----------|-----|-----------|-----|-----------|-----|-----------|-----------|-----------|-----|-----------|-----|-----------|-----|-----------|------|-----------|-----------|-----------|------|-----------|------|------------|------|------------|------|------------|---|------------|------|------------|------|------------|------|---|
| Outdoor unit | (1) The model total of indoor units in the system with one outdoor unit exceeds the following table. <table border="1" style="margin: 10px auto; border-collapse: collapse; text-align: center;"> <thead> <tr> <th style="width: 50%;">Model</th> <th style="width: 50%;">Capacity Total</th> </tr> </thead> <tbody> <tr><td>200 model</td><td>260</td></tr> <tr><td>250 model</td><td>325</td></tr> <tr><td>300 model</td><td>390</td></tr> <tr><td>350 model</td><td>455</td></tr> <tr><td>400 model</td><td>520</td></tr> <tr><td>450 model</td><td>585</td></tr> <tr><td>500 model</td><td>650</td></tr> <tr><td>550 model</td><td>715</td></tr> <tr><td>600 model</td><td>780</td></tr> <tr><td>650 model</td><td>845</td></tr> <tr><td>700 model</td><td>910</td></tr> <tr><td>750 model</td><td>975</td></tr> <tr><td>800 model</td><td>1040</td></tr> <tr><td>850 model</td><td>1105</td></tr> <tr><td>900 model</td><td>1170</td></tr> <tr><td>950 model</td><td>1235</td></tr> <tr><td>1000 model</td><td>1300</td></tr> <tr><td>1050 model</td><td>1365</td></tr> <tr><td>1100 model</td><td>1430</td></tr> <tr><td>1150 model</td><td>1495</td></tr> <tr><td>1200 model</td><td>1560</td></tr> <tr><td>1250 model</td><td>1625</td></tr> </tbody> </table> | Model | Capacity Total | 200 model | 260 | 250 model | 325 | 300 model | 390 | 350 model | 455 | 400 model | 520 | 450 model | 585 | 500 model | 650 | 550 model | 715 | 600 model | 780 | 650 model | 845 | 700 model | 910 | 750 model | 975 | 800 model | 1040 | 850 model | 1105 | 900 model | 1170 | 950 model | 1235 | 1000 model | 1300 | 1050 model | 1365 | 1100 model | 1430 | 1150 model | 1495 | 1200 model | 1560 | 1250 model | 1625 | 1) Check the model total (capacity code total) of indoor units connected. 2) Check the model name (capacity code) of the connected indoor unit set by the switch (SW2 on indoor unit board). When the model name set by the switch is different from that of the unit connected, turn off the power source of the outdoor and the indoor units, and change the setting of the model name (capacity code). |
| | Model | Capacity Total | | | | | | | | | | | | | | | | | | | | | | | | | | | | | | | | | | | | | | | | | | | | | | |
| | 200 model | 260 | | | | | | | | | | | | | | | | | | | | | | | | | | | | | | | | | | | | | | | | | | | | | | |
| 250 model | 325 | | | | | | | | | | | | | | | | | | | | | | | | | | | | | | | | | | | | | | | | | | | | | | | |
| 300 model | 390 | | | | | | | | | | | | | | | | | | | | | | | | | | | | | | | | | | | | | | | | | | | | | | | |
| 350 model | 455 | | | | | | | | | | | | | | | | | | | | | | | | | | | | | | | | | | | | | | | | | | | | | | | |
| 400 model | 520 | | | | | | | | | | | | | | | | | | | | | | | | | | | | | | | | | | | | | | | | | | | | | | | |
| 450 model | 585 | | | | | | | | | | | | | | | | | | | | | | | | | | | | | | | | | | | | | | | | | | | | | | | |
| 500 model | 650 | | | | | | | | | | | | | | | | | | | | | | | | | | | | | | | | | | | | | | | | | | | | | | | |
| 550 model | 715 | | | | | | | | | | | | | | | | | | | | | | | | | | | | | | | | | | | | | | | | | | | | | | | |
| 600 model | 780 | | | | | | | | | | | | | | | | | | | | | | | | | | | | | | | | | | | | | | | | | | | | | | | |
| 650 model | 845 | | | | | | | | | | | | | | | | | | | | | | | | | | | | | | | | | | | | | | | | | | | | | | | |
| 700 model | 910 | | | | | | | | | | | | | | | | | | | | | | | | | | | | | | | | | | | | | | | | | | | | | | | |
| 750 model | 975 | | | | | | | | | | | | | | | | | | | | | | | | | | | | | | | | | | | | | | | | | | | | | | | |
| 800 model | 1040 | | | | | | | | | | | | | | | | | | | | | | | | | | | | | | | | | | | | | | | | | | | | | | | |
| 850 model | 1105 | | | | | | | | | | | | | | | | | | | | | | | | | | | | | | | | | | | | | | | | | | | | | | | |
| 900 model | 1170 | | | | | | | | | | | | | | | | | | | | | | | | | | | | | | | | | | | | | | | | | | | | | | | |
| 950 model | 1235 | | | | | | | | | | | | | | | | | | | | | | | | | | | | | | | | | | | | | | | | | | | | | | | |
| 1000 model | 1300 | | | | | | | | | | | | | | | | | | | | | | | | | | | | | | | | | | | | | | | | | | | | | | | |
| 1050 model | 1365 | | | | | | | | | | | | | | | | | | | | | | | | | | | | | | | | | | | | | | | | | | | | | | | |
| 1100 model | 1430 | | | | | | | | | | | | | | | | | | | | | | | | | | | | | | | | | | | | | | | | | | | | | | | |
| 1150 model | 1495 | | | | | | | | | | | | | | | | | | | | | | | | | | | | | | | | | | | | | | | | | | | | | | | |
| 1200 model | 1560 | | | | | | | | | | | | | | | | | | | | | | | | | | | | | | | | | | | | | | | | | | | | | | | |
| 1250 model | 1625 | | | | | | | | | | | | | | | | | | | | | | | | | | | | | | | | | | | | | | | | | | | | | | | |
| | (2) The model selection switches (SW5-1 - 5-4) on the outdoor unit are set incorrectly. <table border="1" style="margin: 10px auto; border-collapse: collapse; text-align: center;"> <thead> <tr> <th rowspan="2" style="width: 20%;">Model</th> <th colspan="4">SW5</th> </tr> <tr> <th style="width: 5%;">1</th> <th style="width: 5%;">2</th> <th style="width: 5%;">3</th> <th style="width: 5%;">4</th> </tr> </thead> <tbody> <tr><td>200 model</td><td>OFF</td><td>ON</td><td>OFF</td><td>OFF</td></tr> <tr><td>250 model</td><td>ON</td><td>ON</td><td>OFF</td><td>OFF</td></tr> <tr><td>300 model</td><td>OFF</td><td>OFF</td><td>ON</td><td>OFF</td></tr> <tr><td>350 model</td><td>OFF</td><td>ON</td><td>ON</td><td>OFF</td></tr> <tr><td>400 model</td><td>ON</td><td>ON</td><td>ON</td><td>OFF</td></tr> <tr><td>450 model</td><td>OFF</td><td>OFF</td><td>OFF</td><td>ON</td></tr> </tbody> </table> | Model | SW5 | | | | 1 | 2 | 3 | 4 | 200 model | OFF | ON | OFF | OFF | 250 model | ON | ON | OFF | OFF | 300 model | OFF | OFF | ON | OFF | 350 model | OFF | ON | ON | OFF | 400 model | ON | ON | ON | OFF | 450 model | OFF | OFF | OFF | ON | Check the setting for the model selection switch on the outdoor unit (Dipswitches SW5-1 - 5-4 on the outdoor unit control board). | | | | | | | |
| Model | SW5 | | | | | | | | | | | | | | | | | | | | | | | | | | | | | | | | | | | | | | | | | | | | | | | |
| | 1 | 2 | 3 | 4 | | | | | | | | | | | | | | | | | | | | | | | | | | | | | | | | | | | | | | | | | | | | |
| 200 model | OFF | ON | OFF | OFF | | | | | | | | | | | | | | | | | | | | | | | | | | | | | | | | | | | | | | | | | | | | |
| 250 model | ON | ON | OFF | OFF | | | | | | | | | | | | | | | | | | | | | | | | | | | | | | | | | | | | | | | | | | | | |
| 300 model | OFF | OFF | ON | OFF | | | | | | | | | | | | | | | | | | | | | | | | | | | | | | | | | | | | | | | | | | | | |
| 350 model | OFF | ON | ON | OFF | | | | | | | | | | | | | | | | | | | | | | | | | | | | | | | | | | | | | | | | | | | | |
| 400 model | ON | ON | ON | OFF | | | | | | | | | | | | | | | | | | | | | | | | | | | | | | | | | | | | | | | | | | | | |
| 450 model | OFF | OFF | OFF | ON | | | | | | | | | | | | | | | | | | | | | | | | | | | | | | | | | | | | | | | | | | | | |
| | (3) The outdoor unit and the auxiliary unit (OS) that is connected to the same system are not properly connected. | Confirm that the TB3 on the OC and OS are properly connected. | | | | | | | | | | | | | | | | | | | | | | | | | | | | | | | | | | | | | | | | | | | | | | |

1. Error Code

7101

Capacity code setting error

2. Error definition and error detection method

Connection of incompatible (wrong capacity code) indoor unit or outdoor unit

3. Error source, cause, check method and remedy

| Error source | Cause | Check method and remedy | | | | | | | | | | | | | | | | | | | | | | | | | | | | | | | | | | | | | | | |
|-----------------------------|--|---|-----|-----|--|--|---|---|---|---|-----------|-----|----|-----|-----|-----------|----|----|-----|-----|-----------|-----|-----|----|-----|-----------|-----|----|----|-----|-----------|----|----|----|-----|-----------|-----|-----|-----|----|---|
| Outdoor unit Indoor unit | (1) The model name (capacity code) set by the switch (SW2) is wrong. *The capacity of the indoor unit can be confirmed by the self-diagnosis function (SW1 operation) of the outdoor unit. | 1) Check the model name (capacity code) of the indoor unit which has the error source address set by the switch (SW2 on indoor unit board). When the model name set by the switch is different from that of the unit connected, turn off the power source of the outdoor and the indoor units, and change the setting of the capacity code. | | | | | | | | | | | | | | | | | | | | | | | | | | | | | | | | | | | | | | | |
| Outdoor unit | (2) The model selection switches (SW5-1 - 5-4) on the outdoor unit are set incorrectly. <table border="1" style="margin-left: auto; margin-right: auto; border-collapse: collapse; text-align: center;"> <thead> <tr> <th rowspan="2">Model</th> <th colspan="4">SW5</th> </tr> <tr> <th>1</th> <th>2</th> <th>3</th> <th>4</th> </tr> </thead> <tbody> <tr> <td>200 model</td> <td>OFF</td> <td>ON</td> <td>OFF</td> <td>OFF</td> </tr> <tr> <td>250 model</td> <td>ON</td> <td>ON</td> <td>OFF</td> <td>OFF</td> </tr> <tr> <td>300 model</td> <td>OFF</td> <td>OFF</td> <td>ON</td> <td>OFF</td> </tr> <tr> <td>350 model</td> <td>OFF</td> <td>ON</td> <td>ON</td> <td>OFF</td> </tr> <tr> <td>400 model</td> <td>ON</td> <td>ON</td> <td>ON</td> <td>OFF</td> </tr> <tr> <td>450 model</td> <td>OFF</td> <td>OFF</td> <td>OFF</td> <td>ON</td> </tr> </tbody> </table> | Model | SW5 | | | | 1 | 2 | 3 | 4 | 200 model | OFF | ON | OFF | OFF | 250 model | ON | ON | OFF | OFF | 300 model | OFF | OFF | ON | OFF | 350 model | OFF | ON | ON | OFF | 400 model | ON | ON | ON | OFF | 450 model | OFF | OFF | OFF | ON | Check the setting for the model selection switch on the outdoor unit (Dipswitches SW5-1 - 5-4 on the outdoor unit control board). |
| Model | SW5 | | | | | | | | | | | | | | | | | | | | | | | | | | | | | | | | | | | | | | | | |
| | 1 | 2 | 3 | 4 | | | | | | | | | | | | | | | | | | | | | | | | | | | | | | | | | | | | | |
| 200 model | OFF | ON | OFF | OFF | | | | | | | | | | | | | | | | | | | | | | | | | | | | | | | | | | | | | |
| 250 model | ON | ON | OFF | OFF | | | | | | | | | | | | | | | | | | | | | | | | | | | | | | | | | | | | | |
| 300 model | OFF | OFF | ON | OFF | | | | | | | | | | | | | | | | | | | | | | | | | | | | | | | | | | | | | |
| 350 model | OFF | ON | ON | OFF | | | | | | | | | | | | | | | | | | | | | | | | | | | | | | | | | | | | | |
| 400 model | ON | ON | ON | OFF | | | | | | | | | | | | | | | | | | | | | | | | | | | | | | | | | | | | | |
| 450 model | OFF | OFF | OFF | ON | | | | | | | | | | | | | | | | | | | | | | | | | | | | | | | | | | | | | |

1. Error Code

7102

Wrong number of connected units

2. Error definition and error detection method

The number of connected indoor units is "0" or exceeds the allowable value.

3. Error source, cause, check method and remedy

| Error source | Cause | Check method and remedy | | | | | | | | |
|--|---|---|------------------------------------|------------------------------|---|---|--------|-------------------------------|---|---|
| Outdoor unit | <p>(1) Number of indoor units connected to the outdoor terminal block (TB3) for indoor/ outdoor transmission lines exceeds limitations described below.</p> <table border="1" style="margin-left: 20px;"> <thead> <tr> <th style="width: 20%;">Number of units</th> <th>Restriction on the number of units</th> </tr> </thead> <tbody> <tr> <td>Total number of indoor units</td> <td>17 : 200 model 21 : 250 models 26 : 300 models 30 : 350 models 34 : 400 models 39 : 450 models 43 : 500 models 47 : 550 models 50 : 600 - 1250 models</td> </tr> <tr> <td>Total number of LOSSNAY units (During auto address start-up only)</td> <td>0 or 1</td> </tr> <tr> <td>Total number of outdoor units</td> <td>1 : P200 - P450 models 2 : P500 - P900 models 3 : P950 - P1250 models</td> </tr> </tbody> </table> | Number of units | Restriction on the number of units | Total number of indoor units | 17 : 200 model 21 : 250 models 26 : 300 models 30 : 350 models 34 : 400 models 39 : 450 models 43 : 500 models 47 : 550 models 50 : 600 - 1250 models | Total number of LOSSNAY units (During auto address start-up only) | 0 or 1 | Total number of outdoor units | 1 : P200 - P450 models 2 : P500 - P900 models 3 : P950 - P1250 models | <p>1) Check whether the number of units connected to the outdoor terminal block (TB3) for indoor/ outdoor transmission lines does not exceed the limitation. (See (1) and (2) on the left.)</p> |
| | Number of units | Restriction on the number of units | | | | | | | | |
| | Total number of indoor units | 17 : 200 model 21 : 250 models 26 : 300 models 30 : 350 models 34 : 400 models 39 : 450 models 43 : 500 models 47 : 550 models 50 : 600 - 1250 models | | | | | | | | |
| | Total number of LOSSNAY units (During auto address start-up only) | 0 or 1 | | | | | | | | |
| | Total number of outdoor units | 1 : P200 - P450 models 2 : P500 - P900 models 3 : P950 - P1250 models | | | | | | | | |
| (2) Disconnected transmission line of the outdoor unit | 2) Check (2) - (3) on the left. | | | | | | | | | |
| <p>(3) Short-circuited transmission line When (2) and (3) apply, the following display will appear.</p> <ul style="list-style-type: none"> ◆ME remote controller Nothing appears on the remote controller because it is not powered. ◆MA remote controller "HO" or "PLEASE WAIT" blinks. | 3) Check whether the transmission line for the terminal block for centralized control (TB7) is not connected to the terminal block for the indoor/outdoor transmission line (TB3). | | | | | | | | | |
| (4) The model selection switch (SW5-7) on the outdoor unit is set to OFF. (Normally set to ON) | 4) Check the setting for the model selection switch on the outdoor unit (Dipswitches SW5-7 on the outdoor unit control board). | | | | | | | | | |
| (5) Outdoor unit address setting error The outdoor units in the same refrigerant circuit do not have sequential address numbers. | | | | | | | | | | |

1. Error Code

7105

Address setting error

2. Error definition and error detection method

Erroneous setting of OC unit address

3. Cause, check method and remedy

| Error source | Cause | Check method and remedy |
|--------------|---|---|
| Outdoor unit | Erroneous setting of OC unit address The address of outdoor unit is not being set to 51 - 100. | Check that the address of OC unit is set to 51-100. Reset the address if it stays out of the range, while shutting the power source off. |

1. Error Code

7106

Attribute setting error

2. Error definition and error detection method

| Error source | Cause | Check method and remedy | | | | | | |
|---|--|---|------------------|-------|--|-----|---|----|
| - | A remote controller for use with indoor units, such as the MA remote controller, is connected to the OA processing unit whose attribute is FU. | <p>To operate the OA processing unit directly via a remote controller for use with indoor units, such as the MA remote controller, set the DIP SW 3-1 on the OA processing unit to ON.</p> <table border="1" style="margin-left: auto; margin-right: auto;"> <tr> <td style="padding: 2px;">Operation Method</td> <td style="padding: 2px;">SW3-1</td> </tr> <tr> <td style="padding: 2px;">Interlocked operation with the indoor unit</td> <td style="padding: 2px;">OFF</td> </tr> <tr> <td style="padding: 2px;">Direct operation via the MA remote controller</td> <td style="padding: 2px;">ON</td> </tr> </table> | Operation Method | SW3-1 | Interlocked operation with the indoor unit | OFF | Direct operation via the MA remote controller | ON |
| Operation Method | SW3-1 | | | | | | | |
| Interlocked operation with the indoor unit | OFF | | | | | | | |
| Direct operation via the MA remote controller | ON | | | | | | | |

1. Error Code

7110

Connection information signal transmission/reception error

2. Error definition and error detection method

The given indoor unit is inoperable because it is not properly connected to the outdoor unit in the same system.

3. Error source, cause, check method and remedy

| Error source | Cause | Check method and remedy |
|--------------|--|---|
| Outdoor unit | (1) Power to the transmission booster is cut off. | 1) Confirm that the power to the transmission booster is not cut off by the booster being connected to the switch on the indoor unit. (The unit will not function properly unless the transmission booster is turned on.) ->Reset the power to the outdoor unit. |
| | (2) Power resetting of the transmission booster and outdoor unit. | |
| | (3) Wiring failure between OC and OS | 2) Confirm that the TB3 on the OC and OS are properly connected. |
| | (4) Broken wire between OC and OS. | 3) Check the model selection switch on the outdoor unit (Dipswitch SW5-7 on the control board.). |
| | (5) The model selection switch (SW5-7) on the outdoor unit is set to OFF. (Normally set to ON) | |

1. Error Code

7111

Remote controller sensor fault

2. Error definition and error detection method

This error occurs when the temperature data is not sent although the remote controller sensor is specified.

3. Error source, cause, check method and remedy

| Error source | Cause | Check method and remedy |
|-----------------------------------|--|--|
| Indoor unit OA processing unit | The remote controller without the temperature sensor (the wireless remote controller or the ME compact remote controller (mounted type)) is used and the remote controller sensor for the indoor unit is specified. (SW1-1 is ON.) | Replace the remote controller with the one with built-in temperature sensor. |

1. Error Code

7113

Function setting error

2. Error source, cause, check method and remedy

| Error source | Cause | Check method and remedy |
|--------------|---|---|
| Outdoor unit | (1) Wiring failure | 1) Control board connector Check the CNTYP2,4,5 connector connection. INV board connector Check the CNTYP connector connection |
| | (2) Disconnected connector, short circuit, contact failure | 2) Check the compatibility of the circuit board, and replace it with a correct one if necessary. |
| | (3) Incompatibility between the control board and INV board (Replacement of the circuit board with the wrong one) | 3) Check the model selection switch on the outdoor unit (Dipswitch SW5-7 on the control board.). |

1. Error Code

7117

Model setting error

2. Error source, cause, check method and remedy

| Error source | Cause | Check method and remedy |
|--------------|--|--|
| Outdoor unit | (1) Wiring failure | 1) Control board connector Check the CNTYP2,4,5 connector connection. INV board connection Check the CNTYP connector connection |
| | (2) Disconnected connector, short circuit, contact failure | |

1. Error Code

7130

Incompatible unit combination

2. Error definition and error detection method

The check code will appear when the indoor units with different refrigerant systems are connected.

3. Error source, cause, check method and remedy

| Error source | Cause | Check method and remedy |
|--------------|---|--|
| Outdoor unit | The connected indoor unit is for use with R22 or R407C. Incorrect type of indoor units are connected. The M-NET connection adapter is connected to the indoor unit system in a system in which the Slim Model (A control) of units are connected to the M-NET. | Check the connected indoor unit model. Check whether the connecting adapter for M-NET is not connected to the indoor unit. (Connect the connecting adapter for M-NET to the outdoor unit.) |

-1- Troubleshooting according to the remote controller malfunction or the external input error

In the case of MA remote controller

1. Phenomena

Even if the operation button on the remote controller is pressed, the display remains unlit and the unit does not start running. (Power indicator  does not appear on the screen.)

(1) Cause

- 1) The power is not supplied to the indoor unit.
 - The main power of the indoor unit is not on.
 - The connector on the indoor unit board has come off.
 - The fuse on the indoor unit board has melted.
 - Transformer failure and disconnected wire of the indoor unit.
- 2) Incorrect wiring for the MA remote controller
 - Disconnected wire for the MA remote controller or disconnected line to the terminal block.
 - Short-circuited MA remote controller wiring
 - Incorrect wiring of the MA remote controller cables
 - Incorrect connection of the MA remote wiring to the terminal block for transmission line (TB5) on the indoor unit
 - Wiring mixup between the MA remote controller cable and 200 VAC power supply cable
 - Reversed connection of the wire for the MA remote controller and the M-NET transmission line on the indoor unit
- 3) The number of the MA remote controllers that are connected to an indoor unit exceeds the allowable range (2 units).
- 4) The length or the diameter of the wire for the MA remote controller are out of specification.
- 5) Short circuit of the wire for the remote display output of the outdoor unit or reversed polarity connection of the relay.
- 6) The indoor unit board failure
- 7) MA remote controller failure

(2) Check method and remedy

- 1) Measure voltages of the MA remote controller terminal (among 1 to 3).
 - If the voltage is between DC 9 and 12V, the remote controller is a failure.
 - If no voltage is applied, check the causes 1) and 3) and if the cause is found, correct it.
If no cause is found, refer to 2).
- 2) Remove the wire for the remote controller from the terminal block (TB13) on the MA remote controller for the indoor unit, and check voltage among 1 to 3.
 - If the voltage is between DC 9 and 12 V, check the causes 2) and 4) and if the cause is found, correct it.
 - If no voltage is applied, check the cause 1) and if the cause is found, correct it.
If no cause is found, check the wire for the remote display output (relay polarity).
If no further cause is found, replace the indoor unit board.

In the case of MA remote controller

2. Phenomena

When the remote controller operation SW is turned on, the operation status briefly appears on the display, then it goes off, and the display lights out immediately, and the unit stops.

(1) Cause

- 1) The power for the M-NET transmission line is not supplied from the outdoor unit.
- 2) Short circuit of the transmission line.
- 3) Incorrect wiring of the M-NET transmission line on the outdoor unit.
 - Disconnected wire for the MA remote controller or disconnected line to the terminal block.
 - The indoor transmission line is connected incorrectly to the transmission terminal block for centralized controller (TB7).
 - The male power supply connectors on the multiple outdoor units are connected to the female power supply switch connector (CN40).

In the system to which the power supply unit for transmission lines is connected, the male power supply connector is connected to the female power supply switch connector (CN40) on the outdoor unit.
- 4) Disconnected M-NET transmission line on the indoor unit side.
- 5) Disconnected wire between the terminal block for M-NET line (TB5) of the indoor unit and the indoor unit board (CN2M) or disconnected connector.

(2) Check method and remedy

- 1) **When 2) and 3) above apply, check code 7102 will be displayed on the self-diagnosis LED.**

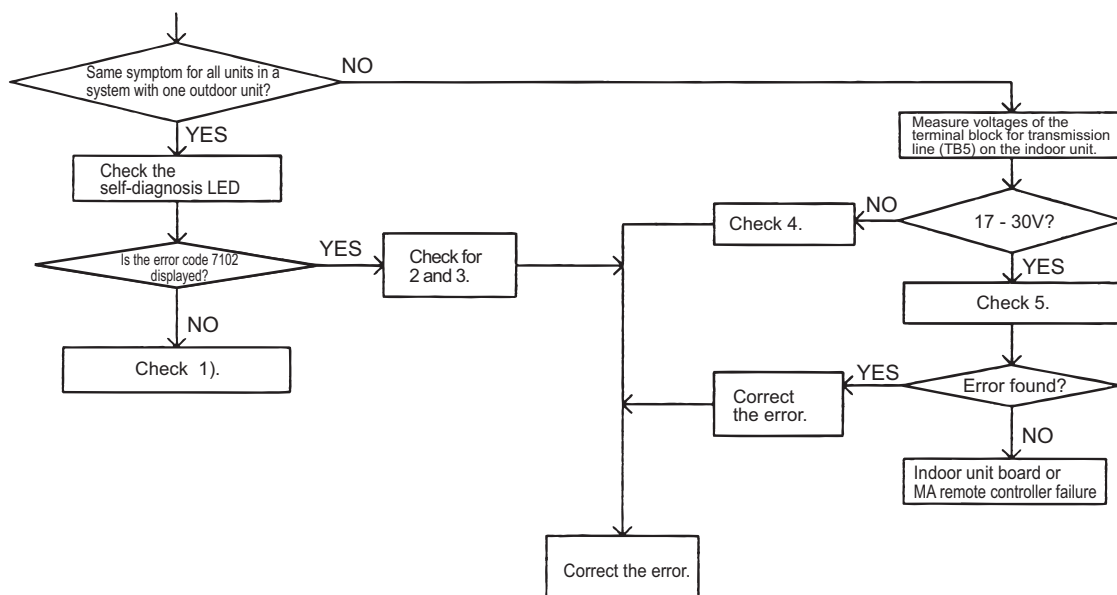

See Section IX [4] -7- (2) Troubleshooting transmission power circuit of outdoor unit for how to check the items in Section 1 in the flowchart above.(page 241)

In the case of MA remote controller

3. Phenomena

"HO" or "PLEASE WAIT" display on the remote controller does not disappear, and no operation is performed even if the button is pressed. ("HO" or "PLEASE WAIT" display will normally turn off 5 minutes later after the power on.)

(1) Cause

- 1) The power for the M-NET transmission line is not supplied from the outdoor unit.
- 2) Short-circuited transmission line
- 3) Incorrect wiring of the M-NET transmission line on the outdoor unit.
 - Disconnected wire for the MA remote controller or disconnected line to the terminal block.
 - The indoor transmission line is connected incorrectly to the transmission terminal block for centralized controller (TB7).
 - The male power supply connectors on the multiple outdoor units are connected to the female power supply switch connector (CN40).

In the system to which the power supply unit for transmission lines is connected, the male power supply connector is connected to the female power supply switch connector (CN40) on the outdoor unit
- 4) Disconnected M-NET transmission line on the indoor unit.
- 5) Disconnected wire between the terminal block for M-NET line (TB5) of the indoor unit and the indoor unit board (CN2M) or disconnected connector.
- 6) Incorrect wiring for the MA remote controller
 - Short-circuited wire for the MA remote controller
 - Disconnected wire for the MA remote controller (No.2) and disconnected line to the terminal block.
 - Reversed daisy-chain connection between groups
 - Incorrect wiring for the MA remote controller to the terminal block for transmission line connection (TB5) on the indoor unit
 - The M-NET transmission line is connected incorrectly to the terminal block (TB13) for the MA remote controller.
- 7) The sub/main setting of the MA remote controller is set to sub.
- 8) 2 or more main MA remote controllers are connected.
- 9) Indoor unit board failure (MA remote controller communication circuit)
- 10) Remote controller failure
- 11) Outdoor unit failure (Refer to IX [7] Troubleshooting Using the Outdoor Unit LED Error Display.)(page 246)

(2) Check method and remedy

- 1) **When 2) and 3) above apply, check code 7102 will be displayed on the self-diagnosis LED.**

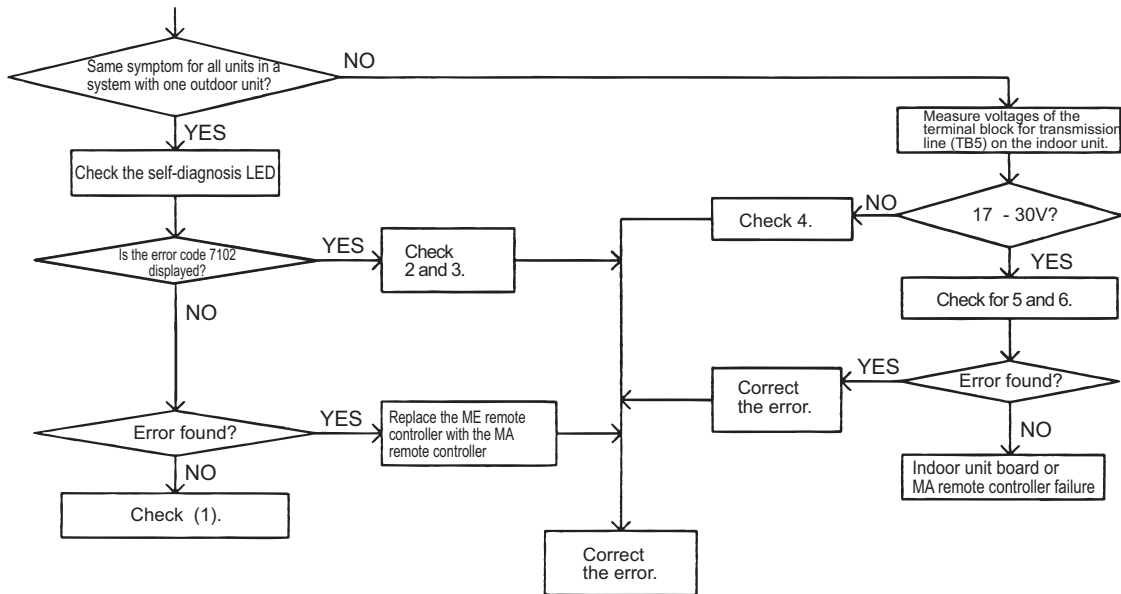

See Section IX [4] -7- (2) Troubleshooting transmission power circuit of outdoor unit for how to check the items in Section 1 in the flowchart above.(page 241)

In case of ME remote controller

1. Phenomena

Even if the operation button on the remote controller is pressed, the display remains unlit and the unit does not start running. (Power indicator ☉ does not appear on the screen.)

(1) Cause

- 1) The power for the M-NET transmission line is not supplied from the outdoor unit.
- 2) Short circuit of the transmission line.
- 3) Incorrect wiring of the M-NET transmission line on the outdoor unit.
 - Disconnected wire for the MA remote controller or disconnected line to the terminal block.
 - The indoor transmission line is connected incorrectly to the transmission terminal block for centralized controller (TB7).
- 4) Disconnected transmission line on the remote controller.
- 5) Remote controller failure
- 6) Outdoor unit failure (Refer to IX [7] Troubleshooting Using the Outdoor Unit LED Error Display)(page 246)

(2) Check method and remedy

- 1) Check voltage of the transmission terminal block for of the ME remote controller.
 - If voltage between is 17V and 30V -> ME remote controller failure
 - When voltage is 17V or less -> Refer to IX [4] -7- (2) " Troubleshooting transmission power circuit of outdoor unit".(page 241)
- 2) **When 2) and 3) above apply, check code 7102 will be displayed on the self-diagnosis LED.**

In case of ME remote controller

2. Phenomena

When the remote controller operation SW is turned on, a temporary operation display is indicated, and the display lights out immediately.

(1) Cause

- 1) The power is not supplied to the indoor unit.
 - The main power of the indoor unit (AC220V) is not on.
 - The connector on the indoor unit board has come off.
 - The fuse on the indoor unit board has melted.
 - Transformer failure and disconnected wire of the indoor unit
 - The indoor unit board failure
- 2) The outdoor control board failure
 - As the indoor unit does not interact with the outdoor unit, the outdoor unit model cannot be recognized.

(2) Check method and remedy

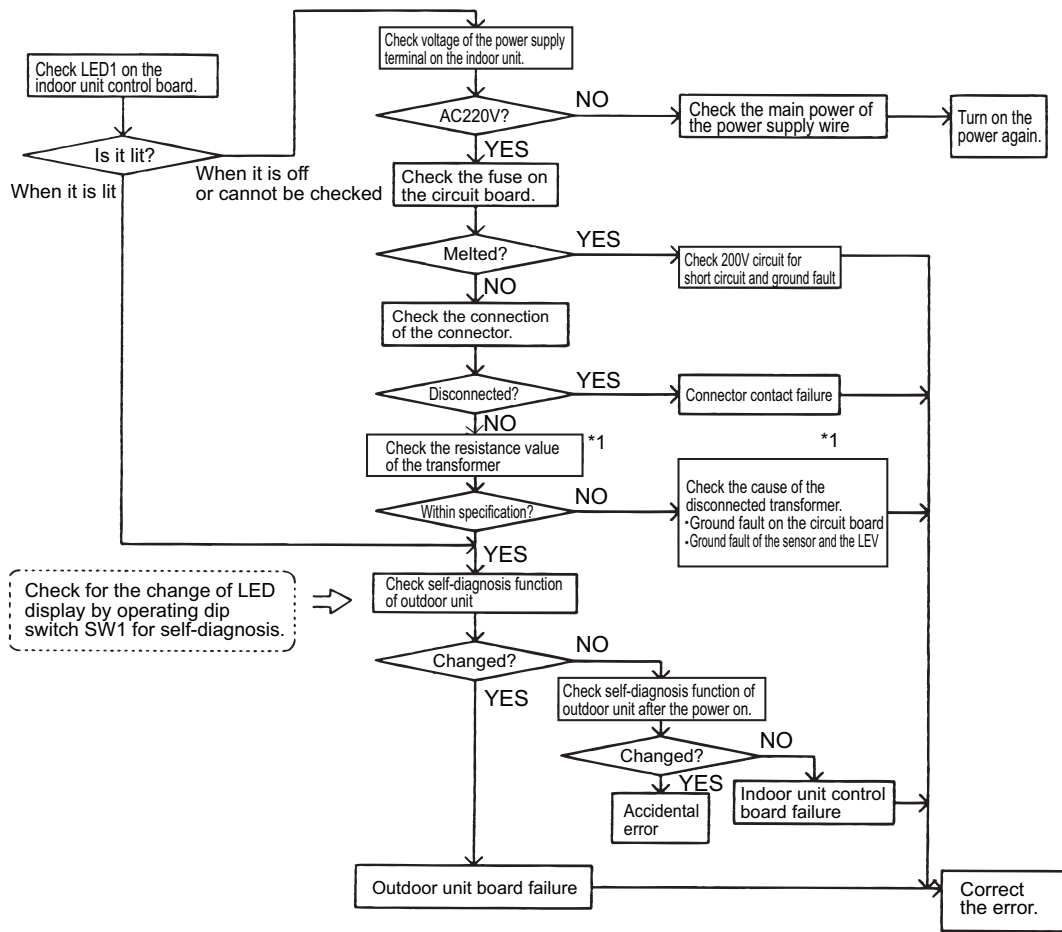

*1. Refer to the parts catalog "transformer check".

In case of ME remote controller

3. Phenomena

"HO" display on the remote controller does not disappear, and no operation is performed even if the button is pressed.

(1) Cause

Without using MELANS

- 1) Outdoor unit address is set to "00"
- 2) A wrong address is set.
 - The address of the indoor unit that is connected to the remote controller is incorrect. (It should equal the ME remote controller address plus 100.)
 - A wrong address is set to the ME remote controller. (100 must be added to the address of the indoor unit.)
- 3) Faulty wiring of the terminal block for transmission line (TB5) of the indoor unit in the same group with the remote controller.
- 4) The centralized control switch (SW2-1) on the outdoor unit is set to ON.
- 5) Disconnection or faulty wiring of indoor unit transmission line.
- 6) Disconnection between the terminal block for M-NET line connection (TB5) of the indoor unit and the male connector (CN2M)
- 7) The male power supply connectors on 2 or more outdoor units are connected to the female power supply switch connector (CN40) for the transmission line for centralized control.
- 8) Outdoor unit control board failure
- 9) Outdoor unit control board failure
- 10) Remote controller failure

Interlocking control with MELANS

- 1) No group registration is made using MELANS. (The indoor unit and the ME remote controller are not grouped.)
- 2) Disconnected transmission line for centralized control (TB7) of the outdoor unit
- 3) The male power supply connector is connected to CN40 on more than one outdoor unit, or the connector is connected to CN40 on the outdoor unit in the system to which a power supply unit for transmission line is connected.

Using MELANS

- 1) When MELANS is used, "HO" display on the remote controller will disappear when the indoor unit and the local remote controller (ME remote controller) are grouped.
If "HO" does not disappear after the registration, check the causes (2) 1) - 3).

(2) Check method and remedy

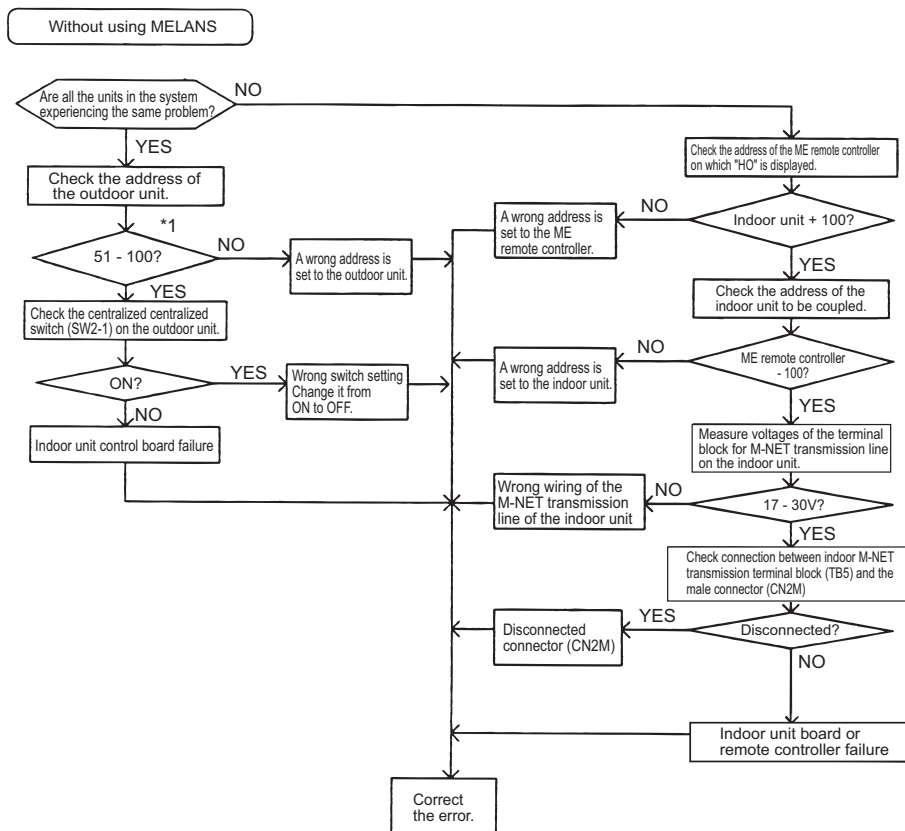

*1. When the indoor unit address is set to 1 - 50, the address will be forcibly set to 100.

In case of ME remote controller

4. Phenomena

"88" appears on the remote controller when the address is registered or confirmed.

(1) Cause, check method and remedy





| Cause | Check method and remedy |
|--|---|
| An error occurs when the address is registered or confirmed. (common) | |
| 1. A wrong address is set to the unit to be coupled. | (1) Confirm the address of unit to be coupled. |
| 2. The transmission line of the unit to be coupled is disconnected or is not connected. | (2) Check the connection of transmission line. |
| 3. Circuit board failure of the unit to be coupled | (3) Check voltage of the terminal block for transmission line of the unit to be coupled. |
| 4. Improper transmission line work | 1) Normal if voltage is between DC17 and 30V. 2) Check (5) in case other than 1). |
| Generates at interlocking registration between LOSSNAY and the indoor unit | |
| 5. The power of LOSSNAY is OFF. | (5) Check for the main power of LOSSNAY. |
| Generates at confirmation of controllers used in the system in which the indoor units connected to different outdoor units are grouped | |
| 6. The power of the outdoor unit to be confirmed has been cut off. | (6) Check the power supply of the outdoor unit which is coupled with the unit to be confirmed. |
| 7. Transmission line is disconnected from the terminal block for central control system connection (TB7) on the outdoor unit. | (7) Check that the transmission line for centralized control (TB7) of the outdoor unit is not disconnected. |
| 8. When the indoor units connected to different outdoor units are grouped without MELANS, the male power supply connector is not connected to the female power supply switch connector (CN40) for the transmission line for centralized control. | (8) Check voltage of the transmission line for centralized control. |
| 9. The male power supply connectors on 2 or more outdoor units are connected to the female power supply switch connector (CN40) for the transmission line for centralized control. | 1) Normal when voltage is between 10V and 30V |
| 10. In the system to which MELANS is connected, the male power supply connector is connected to the female power supply switch connector (CN40) for the transmission line for centralized control. | 2) Check 8 - 11 described on the left in case other than 1). |
| 11. Short circuit of the transmission line for centralized control | |

Both for MA remote controller and ME remote controller

1. Phenomena

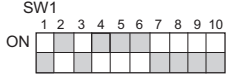
Although cooling operation starts with the normal remote controller display, the capacity is not enough

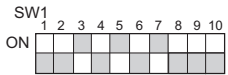
(1) Cause, check method and remedy

| Cause | Check method and remedy |
|---|--|
| <p>1. Compressor frequency does not rise sufficiently.</p> <ul style="list-style-type: none"> ♦Faulty detection of pressure sensor. ♦Protection works and compressor frequency does not rise due to high discharge temperature ♦Protection works and compressor frequency does not rise due to high pressure ♦Pressure drops excessively. | <p>(1) Check pressure difference between the detected pressure by the pressure sensor and the actual pressure with self-diagnosis LED. -> If the accurate pressure is not detected, check the pressure sensor. (Refer to the page on Troubleshooting of Pressure Sensor).</p> <p>Note: Lower inlet pressure by the low pressure sensor than the actual pressure causes insufficient capacity. SW1 setting</p> <p>High pressure sensor</p>  <p>Low pressure sensor</p>  <p>(2) Check temperature difference between the evaporating temperature (Te) and the target evaporating temperature (Tem) with self-diagnosis LED.</p> <p>Note: Higher Te than Tem causes insufficient capacity. SW1 setting</p> <p>Evaporating temperature Te</p>  <p>Target evaporating temperature Tem</p>  <p>Note: Protection works and compressor frequency does not rise even at higher Te than Tem due to high discharge temperature and high pressure. At high discharge temperature: Refer to 1102.(page 159) At high pressure: Refer to 1302.(page 161)</p> |
| <p>2. Indoor unit LEV malfunction</p> <ul style="list-style-type: none"> ♦Insufficient refrigerant flows due to LEV malfunction (not enough opening) or protection works and compressor frequency does not rise due to pressure drop. ♦Refrigerant leak from LEV on the stopping unit causes refrigerant shortage on the running unit. | <p>Refer to the page of LEV troubleshooting ([4] -5).(page 226)</p> |
| <p>3. RPM error of the outdoor unit FAN</p> <ul style="list-style-type: none"> ♦Motor failure or board failure, or airflow rate decrease due to clogging of the heat exchanger ♦The fan is not properly controlled as the outdoor temperature cannot be precisely detected by the temperature sensor. ♦The fan is not properly controlled as the pressure cannot be precisely detected by the pressure sensor. | <p>Refer to the page on troubleshooting of the outdoor unit fan. Refer to 5106.(page 179) Refer to 1302.(page 161)</p> |

| Cause | Check method and remedy |
|--|---|
| 4. Long piping length The cooling capacity varies greatly depending on the pressure loss. (When the pressure loss is large, the cooling capacity drops.) | Check the piping length to determine if it is contributing to performance loss. Piping pressure loss can be estimated from the temperature difference between the indoor unit heat exchanger outlet temperature and the saturation temperature (Te) of 63LS. ->Correct the piping. |
| 5. Piping size is not proper (thin) | |
| 6. Insufficient refrigerant amount Protection works and compressor frequency does not rise due to high discharge temperature. | Refer to 1-1. (Compressor frequency does not rise sufficiently.)Refer to the page on refrigerant amount adjustment |
| 7. Clogging by foreign object | Check the temperature difference between in front of and behind the place where the foreign object is clogging the pipe (upstream side and downstream side). When the temperature drops significantly, the foreign object may clog the pipe. -> Remove the foreign object inside the pipe. |
| 8. The indoor unit inlet temperature is excessively. (Less than 15°C [59°F] WB) | Check the inlet air temperature and for short cycling. Change the environment where the indoor unit is used. |
| 9. Compressor failure The amount of circulating refrigerant decreases due to refrigerant leak in the compressor. | Check the discharge temperature to determine if the refrigerant leaks, as it rises if there is a leak. |
| 10. LEV1 malfunction Sufficient liquid refrigerant is not be supplied to the indoor unit as sufficient sub cool cannot be secured due to LEV1 malfunction. | Refer to the page of LEV troubleshooting ([4] -5-).(page 226) It most likely happens when there is little difference or no difference between TH3 and TH6. |
| 11. TH3, TH6 and 63HS1 sensor failure or faulty wiring LEV1 is not controlled normally. | <ul style="list-style-type: none"> •Check the thermistor. •Check wiring. |
| 12. LEV2 actuation failure A drop in the low pressure that is caused either by a blockage of liquid pipe or by a pressure loss and the resultant slowing of refrigerant flow causes a tendency for the discharge temperature to rise. | Refer to the page on troubleshooting the LEV ([4] -5-).(page 226) |

2. Phenomena

Although heating operation starts with the normal remote controller display, the capacity is not enough.

(1) Cause, check method and remedy

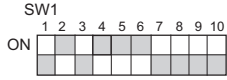
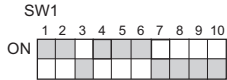
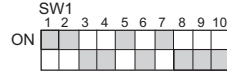
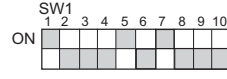
| Cause | Check method and remedy |
|--|---|
| <p>1. Compressor frequency does not rise sufficiently.</p> <ul style="list-style-type: none"> •Faulty detection of pressure sensor. •Protection works and compressor frequency does not rise due to high discharge temperature •Protection works and compressor frequency does not rise due to high pressure. | <p>(1) Check pressure difference between the detected pressure by the pressure sensor and the actual pressure with self-diagnosis LED. -> If the accurate pressure is not detected, check the pressure sensor.(Refer to the page on Troubleshooting of Pressure Sensor)</p> <p>Note: Higher inlet pressure by the high pressure sensor than the actual pressure causes insufficient capacity. SW1 setting</p> <p>High pressure sensor</p>  <p>Low pressure sensor</p>  <p>(2) Check the difference between the condensing temperature (Tc) and the target condensing temperature (Tcm) with self-diagnosis LED.</p> <p>Note: Higher Tc than Tcm causes insufficient capacity. SW1 setting</p> <p>Condensing temperature Tc</p>  <p>Target condensing temperature Tcm</p>  <p>Note: Protection works and compressor frequency does not rise even at lower Tc than Tcm due to high discharge temperature and high pressure. At high discharge temperature: Refer to 1102.(page 159) At high pressure: Refer to 1302.(page 161)</p> |

| Cause | Check method and remedy |
|---|---|
| 2. Indoor unit LEV malfunction Insufficient refrigerant flows due to LEV malfunction (not enough opening). | Refer to the page of LEV troubleshooting ([4] -5-).(page 226) |
| 3. Temperature reading error on the indoor unit piping temperature sensor If the temperature reading on the sensor is higher than the actual temperature, it makes the subcool seem smaller than it is, and the LEV opening decreases too much. | Check the thermistor. |
| 4. RPM error of the outdoor unit FAN ♦Motor failure or board failure, or airflow rate decrease, pressure drop due to clogging of the heat exchanger leading to high discharge temperature ♦The fan is not properly controlled as the temperature cannot be precisely detected with the piping sensor. | Refer to the page on outdoor unit fan ([4] -4-).(page 225) |
| 5. Insulation failure of the refrigerant piping | |
| 6. Long piping length Excessively long piping on the high pressure side causes pressure loss leading to increase in the high pressure. | Confirm that the characteristic of capacity drop due to piping length. -> Change the pipe |
| 7. Piping size is not proper (thin) | |
| 8. Clogging by foreign object | Check the temperature difference between the upstream and the downstream of the pipe section that is blocked. Since blockage in the extended section is difficult to locate, operate the unit in the cooling cycle, and follow the same procedures that are used to locate the blockage of pipe during cooling operation. ->Remove the blockage in the pipe. |
| 9. The indoor unit inlet temperature is excessively high.(exceeding 28°C [82°F]) | Check the inlet air temperature and for short cycling. Change the environment where the indoor unit is used. |
| 10. Insufficient refrigerant amount Protection works and compressor frequency does not rise due to low discharge temperature Refrigerant recovery operation is likely to start. | Refer to 2 - 1. (Compressor frequency does not rise sufficiently.)(page 216) Refer to the page on refrigerant amount adjustment.(page 109) |
| 11. Compressor failure (same as in case of cooling) | Check the discharge temperature. |
| 12. LEV2 actuation failure A drop in the low pressure that is caused either by a blockage of liquid pipe or by a pressure loss and the resultant slowing of refrigerant flow causes a tendency for the discharge temperature to rise. | Refer to the page on troubleshooting the LEV ([4] -5-).(page 226) |

3. Phenomena

Outdoor unit stops at times during operation.

(1) Cause, check method and remedy

| Cause | Check method and remedy |
|---|---|
| <p>The first stop is not considered as an error, as the unit turns to anti-restart mode for 3 minutes as a preliminary error.</p> <p>Error mode</p> <p>1) Abnormal high pressure</p> <p>2) Abnormal discharge air temperature</p> <p>3) Heatsink thermistor failure</p> <p>4) Thermistor failure</p> <p>5) Pressure sensor failure</p> <p>6) Over-current break</p> <p>7) Refrigerant overcharge</p> <p>Note1: Frost prevention tripping only under cooling mode may be considered in addition to the above. (Freeze protection is detected by one or all indoor units.)</p> <p>Note2: Even the second stop is not considered as an error when some specified errors occur. (eg. The third stop is considered as an error when the thermistor error occurs.)</p> | <p>(1) Check the mode operated in the past by displaying preliminary error history on LED display with SW1.</p> <p>(2) Reoperate the unit to find the mode that stops the unit by displaying preliminary error history on LED display with SW1. Refer to the reference page for each error mode.</p> <p>*Display the indoor piping temperature table with SW1 to check whether the freeze proof operation runs properly, and check the temperature.</p> |

[3] Investigation of Transmission Wave Shape/Noise

1. M-NET transmission

Control is performed by exchanging signals between the outdoor unit and the indoor unit (ME remote controller) through M-NET transmission. Noise interference on the transmission line will interrupt the normal transmission, leading to erroneous operation.

(1) Symptoms caused by noise interference on the transmission line

| Cause | Erroneous operation | Error code | Error code definition |
|---|---|--------------|---------------------------------------|
| Noise interference on the transmission line | Signal is transformed and will be misjudged as the signal of another address. | 6600 | Address overlap |
| | Transmission wave pattern is transformed due to the noise creating a new signal | 6602 | Transmission processor hardware error |
| | Transmission wave pattern is transformed due to the noise, and will not be received normally leading to no acknowledgement (ACK). | 6607 | No ACK error |
| | Transmission cannot be performed due to the fine noise. | 6603 | Transmission line bus busy error |
| | Transmission is successful; however, the acknowledgement (ACK) or the response cannot be received normally due to the noise. | 6607 6608 | No ACK error No response error |

(2) Wave shape check

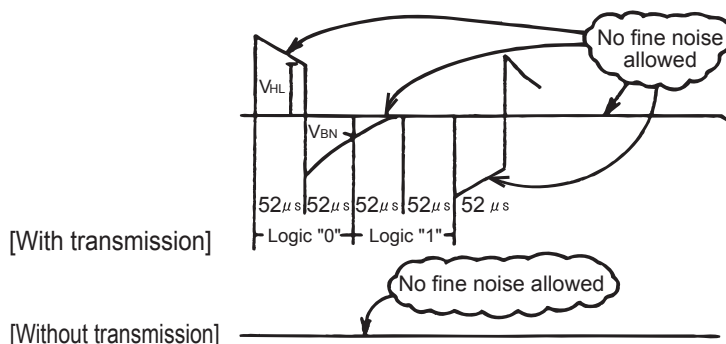

Wave shape check

Check the wave pattern of the transmission line with an oscilloscope. The following conditions must be met.

- Small wave pattern (noise) must not exist on the transmission signal. (Minute noise (approximately 1V) can be generated by DC-DC converter or the inverter operation; however, such noise is not a problem when the shield of the transmission line is grounded.)
- The sectional voltage level of transmission signal should be as follows.

| Logic | Voltage level of the transmission line |
|-------|--|
| 0 | $V_{HL} = 2.5V$ or higher |
| 1 | $V_{BN} = 1.3V$ or below |

(3) Check method and remedy

1) Measures against noise

Check the followings when noise exists on the wave or the errors described in (1) occur.

| | Error code definition | Remedy |
|---|---|--|
| Check that the wiring work is performed according to wiring specifications. | 1. The transmission line and the power line are not wired too closely. | Isolate the transmission line from the power line (5cm [1-31/32"] or more). Do not insert them in the same conduit. |
| | 2. The transmission line is not bundled with that for another systems. | The transmission line must be isolated from another transmission line. When they are bundled, erroneous operation may be caused. |
| | 3. The specified wire is used for the transmission line. | Use the specified transmission line. Type: Shielded wire CVVS/CPEVS/MVVS (For ME remote controller) Diameter: 1.25mm ² [AWG16] or more (Remote controller wire: 0.3 - 1.25mm ² [AWG22-16]) |
| | 4. When the transmission line is daisy-chained on the indoor unit terminals, are the shields daisy-chained on the terminals, too? | The transmission is two-wire daisy-chained. The shielded wire must be also daisy-chained. When the shielded cable is not daisy-chained, the noise cannot be reduced enough. |
| Check that the grounding work is performed according to grounding specifications. | 5. Is the shield of the indoor-outdoor transmission cable grounded to the earth terminal on the outdoor unit? | Connect the shield of the indoor-outdoor transmission cable to the earth terminal (⌚) on the outdoor unit. If no grounding is provided, the noise on the transmission line cannot escape leading to change of the transmission signal. |
| | 6. Check the treatment method of the shield of the transmission line (for centralized control). | The transmission cable for centralized control is less subject to noise interference if it is grounded to the outdoor unit whose power jumper cable was moved from CN41 to CN40 or to the power supply unit. The environment against noise varies depending on the distance of the transmission lines, the number of the connected units, the type of the controllers to be connected, or the environment of the installation site. Therefore, the transmission line work for centralized control must be performed as follows. 1. When no grounding is provided: Ground the shield of the transmission cable by connecting to the outdoor unit whose power jumper connector was moved from CN41 to CN40 or to the power supply unit. 2. When an error occurs even though one point grounding is provided: Ground the shield on all outdoor units. |

2) Check the followings when the error "6607" occurs, or "HO" appears on the display on the remote controller.

| Error code definition | Remedy |
|---|---|
| 7. The farthest distance of transmission line is 200m [656ft] or longer. | Check that the farthest distance from the outdoor unit to the indoor unit and to the remote controller is within 200m [656ft]. |
| 8. The types of transmission lines are different. | Use the specified transmission line. Type: Shielded wire CVVS/CPEVS/MVVS (For ME remote controller) Diameter: 1.25mm ² [AWG16] or more (Remote controller wire: 0.3-1.25mm ² [AWG22-16]) |
| 9. Outdoor unit circuit board failure | Replace the outdoor unit control board or the power supply board for the transmission line. |
| 10. Indoor unit circuit board failure or remote controller failure | Replace the indoor unit circuit board or the remote controller. |
| 11. The MA remote controller is connected to the M-NET transmission line. | Connect the MA remote controller to the terminal block for MA remote controller (TB15). |

2. MA remote controller transmission

The communication between the MA remote controller and the indoor unit is performed with current tone burst.

(1) Symptoms caused by noise interference on the transmission line

If noise is generated on the transmission line, and the communication between the MA remote controller and the indoor unit is interrupted for 3 minutes in a row, MA transmission error (6831) will occur.

(2) Confirmation of transmission specifications and wave pattern

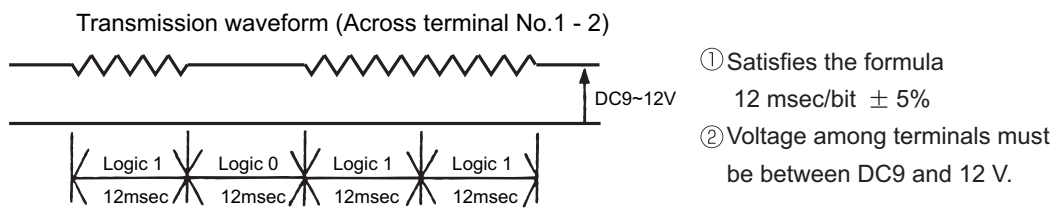
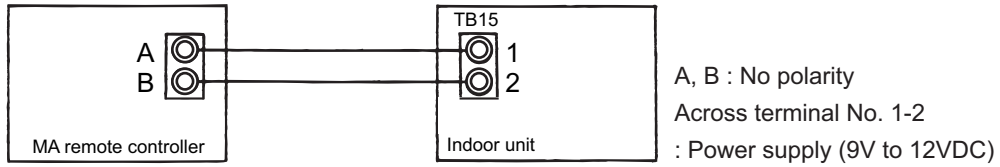

[4] Troubleshooting Principal Parts

-1- High-Pressure Sensor (63HS1)

1. **Compare the pressure that is detected by the high pressure sensor, and the high-pressure gauge pressure to check for failure.**

By configuring the digital display setting switch (SW1) as shown in the figure below, the pressure as measured by the high-pressure sensor appears on the LED1 on the control board.

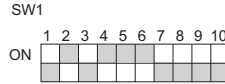

(1) While the sensor is stopped, compare the gauge pressure and the pressure displayed on self-diagnosis LED1.

- 1) When the gauge pressure is between 0 and 0.098MPa [14psi], internal pressure is caused due to gas leak.
- 2) When the pressure displayed on self-diagnosis LED1 is between 0 and 0.098MPa [14psi], the connector may be defective or be disconnected. Check the connector and go to (4).
- 3) When the pressure displayed on self-diagnosis LED1 exceeds 4.15MPa [601psi], go to (3).
- 4) If other than 1), 2) or 3), compare the pressures while the sensor is running. Go to (2).

(2) Compare the gauge pressure and the pressure displayed on self-diagnosis LED1 while the sensor is running. (Compare them by MPa [psi] unit.)

- 1) When the difference between both pressures is within 0.098MPa [14psi], both the high pressure sensor and the control board are normal.
- 2) When the difference between both pressures exceeds 0.098MPa [14psi], the high pressure sensor has a problem. (performance deterioration)
- 3) When the pressure displayed on self-diagnosis LED1 does not change, the high pressure sensor has a problem.

(3) Remove the high pressure sensor from the control board to check the pressure on the self-diagnosis LED1.

- 1) When the pressure displayed on self-diagnosis LED1 is between 0 and 0.098MPa [14psi], the high pressure sensor has a problem.
- 2) When the pressure displayed on self-diagnosis LED1 is approximately 4.15MPa [601psi], the control board has a problem.

(4) Remove the high pressure sensor from the control board, and short-circuit between the No.2 and 3 connectors (63HS1) to check the pressure with self-diagnosis LED1.

- 1) When the pressure displayed on the self-diagnosis LED1 exceeds 4.15MPa [601psi], the high pressure sensor has a problem.
- 2) If other than 1), the control board has a problem.

2. High-pressure sensor configuration

The high pressure sensor consists of the circuit shown in the figure below. If DC 5V is applied between the red and the black wires, voltage corresponding to the pressure between the white and the black wires will be output, and the value of this voltage will be converted by the microcomputer. The output voltage is 0.071V per 0.098MPa [14psi].

Note

The pressure sensor on the body side is designed to connect to the connector. The connector pin number on the body side is different from that on the control board side.

| | Body side | Control board side |
|------|-----------|--------------------|
| Vcc | Pin 1 | Pin 3 |
| Vout | Pin 2 | Pin 2 |
| GND | Pin 3 | Pin 1 |

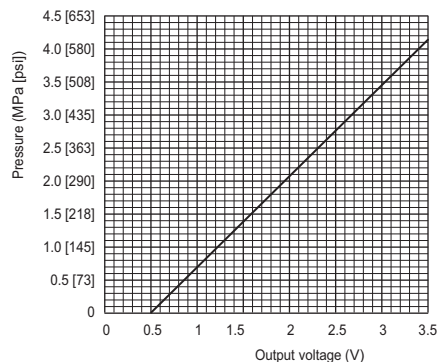
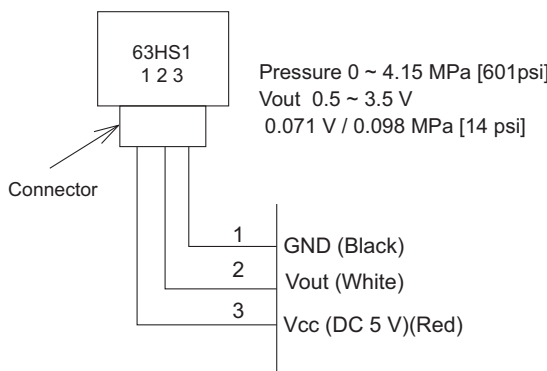

-2- Low-Pressure Sensor (63LS)

1. Compare the pressure that is detected by the low pressure sensor, and the low pressure gauge pressure to check for failure.

By configuring the digital display setting switch (SW1) as shown in the figure below, the pressure as measured by the low-pressure sensor appears on the LED1 on the control board.

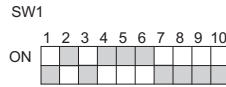

(1) While the sensor is stopped, compare the gauge pressure and the pressure displayed on self-diagnosis LED1.

- 1) When the gauge pressure is between 0 and 0.098MPa [14psi], internal pressure is caused due to gas leak.
- 2) When the pressure displayed on self-diagnosis LED1 is between 0 and 0.098MPa [14psi], the connector may be defective or be disconnected. Check the connector and go to (4).
- 3) When the pressure displayed on self-diagnosis LED1 exceeds 1.7MPa [247psi], go to (3).
- 4) If other than 1), 2) or 3), compare the pressures while the sensor is running. Go to (2).

(2) Compare the gauge pressure and the pressure displayed on self-diagnosis LED1 while the sensor is running.(Compare them by MPa [psi] unit.)

- 1) When the difference between both pressures is within 0.03MPa [4psi], both the low pressure sensor and the control board are normal.
- 2) When the difference between both pressures exceeds 0.03MPa [4psi], the low pressure sensor has a problem. (performance deterioration)
- 3) When the pressure displayed on the self-diagnosis LED1 does not change, the low pressure sensor has a problem.

(3) Remove the low pressure sensor from the control board to check the pressure with the self-diagnosis LED1 display.

- 1) When the pressure displayed on the self-diagnosis LED1 is between 0 and 0.098MPa [14psi], the low pressure sensor has a problem.
- 2) When the pressure displayed on self-diagnosis LED1 is approximately 1.7MPa [247psi], the control board has a problem.
 - When the outdoor temperature is 30°C [86°F] or less, the control board has a problem.
 - When the outdoor temperature exceeds 30°C [86°F], go to (5).

(4) Remove the low pressure sensor from the control board, and short-circuit between the No.2 and 3 connectors (63LS:CN202) to check the pressure with the self-diagnosis LED1.

- 1) When the pressure displayed on the self-diagnosis LED1 exceeds 1.7MPa [247psi], the low pressure sensor has a problem.
- 2) If other than 1), the control board has a problem.

(5) Remove the high pressure sensor (63HS1) from the control board, and insert it into the connector for the low pressure sensor (63LS) to check the pressure with the self-diagnosis LED1.

- 1) When the pressure displayed on the self-diagnosis LED1 exceeds 1.7MPa [247psi], the control board has a problem.
- 2) If other than 1), the control board has a problem.

2. Low-pressure sensor configuration

The low pressure sensor consists of the circuit shown in the figure below. If DC5V is applied between the red and the black wires, voltage corresponding to the pressure between the white and the black wires will be output, and the value of this voltage will be converted by the microcomputer. The output voltage is 0.173V per 0.098MPa [14psi].

Note

The pressure sensor on the body side is designed to connect to the connector. The connector pin number on the body side is different from that on the control board side.

| | Body side | Control board side |
|------|-----------|--------------------|
| Vcc | Pin 1 | Pin 3 |
| Vout | Pin 2 | Pin 2 |
| GND | Pin 3 | Pin 1 |

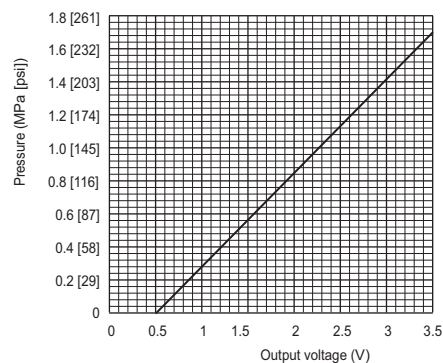
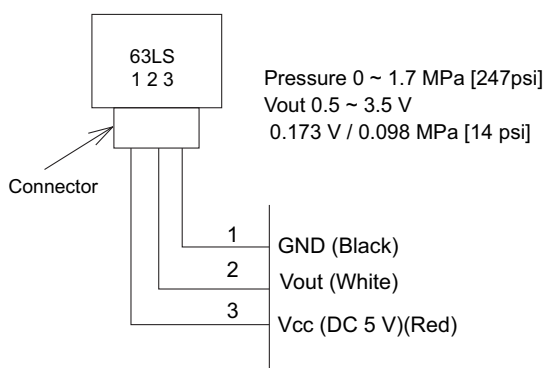

-3- Solenoid Valve

Check whether the output signal from the control board and the operation of the solenoid valve match. Setting the self-diagnosis switch (SW1) as shown in the figure below causes the ON signal of each relay to be output to the LED's. Each LED shows whether the relays for the following parts are ON or OFF. LEDs light up when relays are ON.

Note

The circuits on some parts are closed when the relays are ON. Refer to the following instructions.

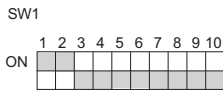
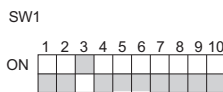
| SW1 | | Display | | | | | | | |
|---|-------|---------|-----|-------|------|------|-----|-----|-----|
| | | LD1 | LD2 | LD3 | LD4 | LD5 | LD6 | LD7 | LD8 |
|  | Upper | 21S4a | | CH11 | | SV1a | | | |
| | Lower | | | 21S4b | SV5b | | | | |
|  | Upper | | | | | | | SV9 | |
| | Lower | | | | | | | | |

When a valve malfunctions, check if the wrong solenoid valve coil is not attached the lead wire of the coil is not disconnected, the connector on the board is not inserted wrongly, or the wire for the connector is not disconnected.

(1) In case of 21S4a (4-way switching valve)

About this 4-way valve

When not powered:

Conducts electricity between the oil separator outlet and heat exchanger, and between the gas ball valve (BV1) and the accumulator to complete the circuit for the cooling cycle.

When powered:

The electricity runs between the oil separator and the gas ball valve, and between the heat exchanger and the accumulator. This circulation is for heating.

Check the LED display and the intake and the discharge temperature for the 4-way valve to check whether the valve has no faults and the electricity runs between where and where. Do not touch the pipe when checking the temperature, as the pipe on the oil separator side will be hot.

Note

Do not give an impact from outside, as the outer hull will be deformed leading to the malfunction of the inner valve.

(2) In case of 21S4b (4-way switching valve) (only for P350-P450 models)

About this 4-way valve

When not powered:

Conducts electricity between the oil separator outlet and the heat exchanger1 (the top heat exchanger) and opens and closes the heat exchanger circuit for the heating and cooling cycles.

When powered:

The electricity runs between the heat exchanger and the accumulator, and the valve opens or closes the heat exchanger circuit when cooling or heating.

Whether the valve has no fault can be checked by checking the LED display and the switching sound; however, it may be difficult to check by the sound, as the switching coincides with 21S4b or 21S4c. In this case, check the intake and the discharge temperature for the 4-way valve to check that the electricity runs between where and where.

Note

- Do not touch the valve when checking the temperature, as it will be hot.
- Do not give an impact from outside, as the outer hull will be deformed leading to the malfunction of the inner valve.

(3) In case of SV1a (Bypass valve)

This solenoid valve opens when powered (Relay ON).

- 1) At compressor start-up, the SV1a turns on for 4 minutes, and the operation can be checked by the self-diagnosis LED display and the closing sound.
- 2) To check whether the valve is open or closed, check the change of the SV1a downstream piping temperature while the valve is being powered. Even when the valve is closed, high-temperature refrigerant flows inside the capillary next to the valve. (Therefore, temperature of the downstream piping will not be low with the valve closed.)

(4) In the case of SV5b (Solenoid valve) (only for P350-P450 models)

This solenoid valve is a switching valve that closes when energized. Proper operation of this valve can be checked on the LED and by listening for the switching sound. During the cooling mode, SV5b is switched simultaneously with 21S4b, which may make it difficult to check for proper operation of the SV5b by listening for the switching sound. If this is the case, pipe temperatures before and after SV5b can be used to determine if the refrigerant is flowing in the pipe.

(5) In the case of SV9 (Solenoid valve)

This solenoid valve is a switching valve that opens when energized. Proper operation of this valve can be checked on the LED display and by the switching sound.

Note

Do not give an impact from outside, as the outer hull will be deformed leading to the malfunction of the inner valve.

-4- Outdoor Unit Fan

- To check the revolution of the fan, check the inverter output state on the self-diagnosis LED, as the inverter on the outdoor fan controls the revolutions of the fan.
- When starting the fan, the fan runs at full speed for 5 seconds.
- When setting the DIP SW1 as shown in the figure below, the inverter output [%] will appear. 100% indicates the full speed and 0% indicates the stopping.

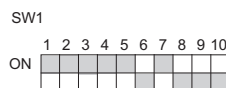

- As the revolution of the fan changes under control, at the interphase or when the indoor unit operation capacity is low, the revolution of the fan may change.
- If the fan does not move or it vibrates, Fan board problem or fan motor problem is suspected. Refer to IX [4] -6- (2) [5] "Check the fan motor ground fault or the winding."(page 235) and IX [4] -6- (2) [6] "Check the Fan board failure."(page 236)

-5- LEV

LEV operation

LEV (Indoor unit: Linear expansion valve), LEV2 (Outdoor unit: Linear expansion valve) are stepping-motor-driven valves that operate by receiving the pulse signals from the indoor and outdoor unit control boards.

(1) Indoor LEV and Outdoor LEV (LEV2)

The valve opening changes according to the number of pulses.

1) Indoor unit control board and the LEV (Indoor unit: Linear expansion valve)

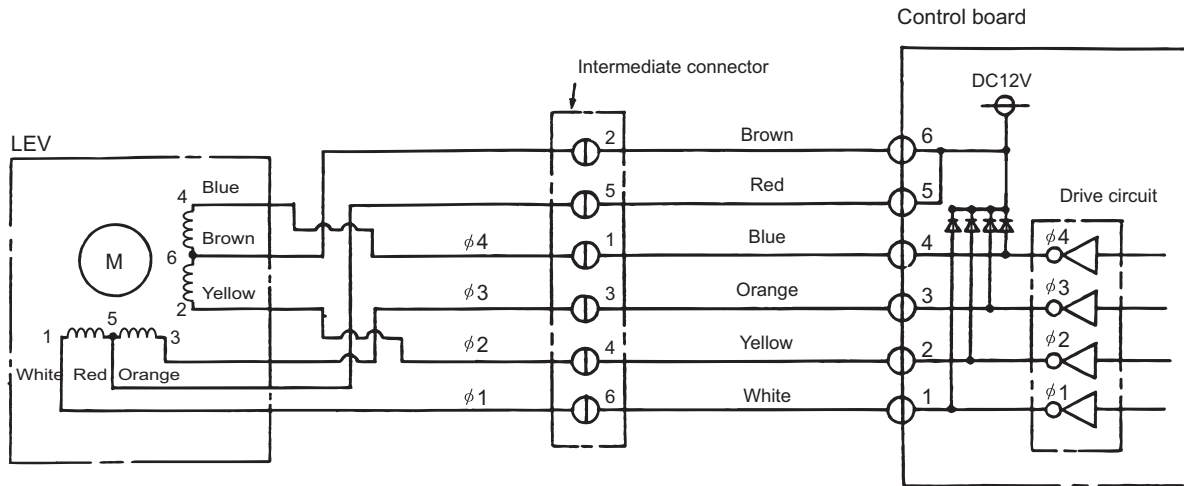

Note. The connector numbers on the intermediate connector and the connector on the control board differ. Check the color of the lead wire to judge the number.

2) Outdoor unit control board and the LEV (Outdoor unit: Linear expansion valve)

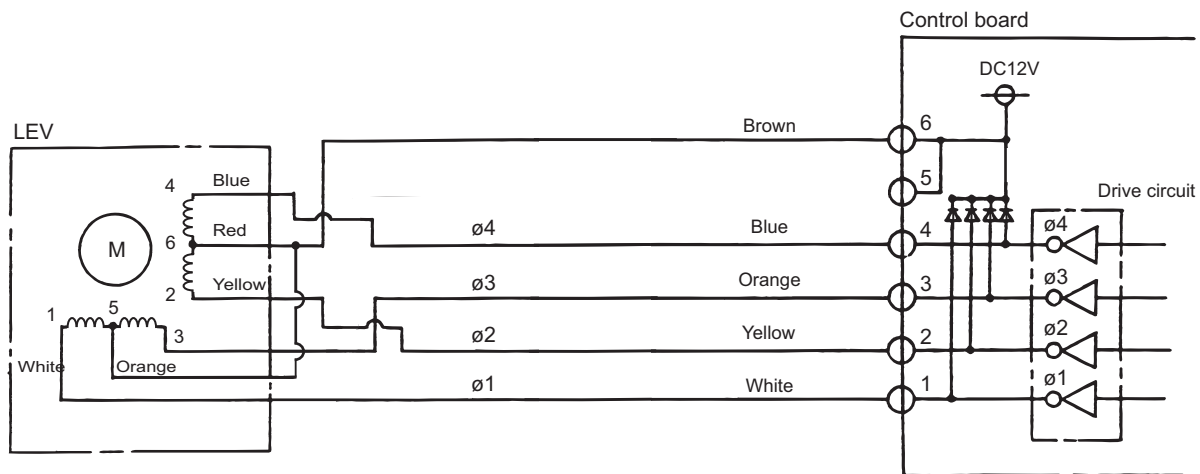

3) Pulse signal output and valve operation

| Output (phase) number | Output state | | | |
|-----------------------|--------------|-----|-----|-----|
| | 1 | 2 | 3 | 4 |
| φ 1 | ON | OFF | OFF | ON |
| φ 2 | ON | ON | OFF | OFF |
| φ 3 | OFF | ON | ON | OFF |
| φ 4 | OFF | OFF | ON | ON |

Output pulses change in the following orders when the Valve is closed; 1 → 2 → 3 → 4 → 1
Valve is open; 4 → 3 → 2 → 1 → 4

- *1. When the LEV opening angle does not change, all the output phases will be off.
- *2. When the output is open phase or remains ON, the motor cannot run smoothly, and rattles and vibra

4) LEV closing and opening operation

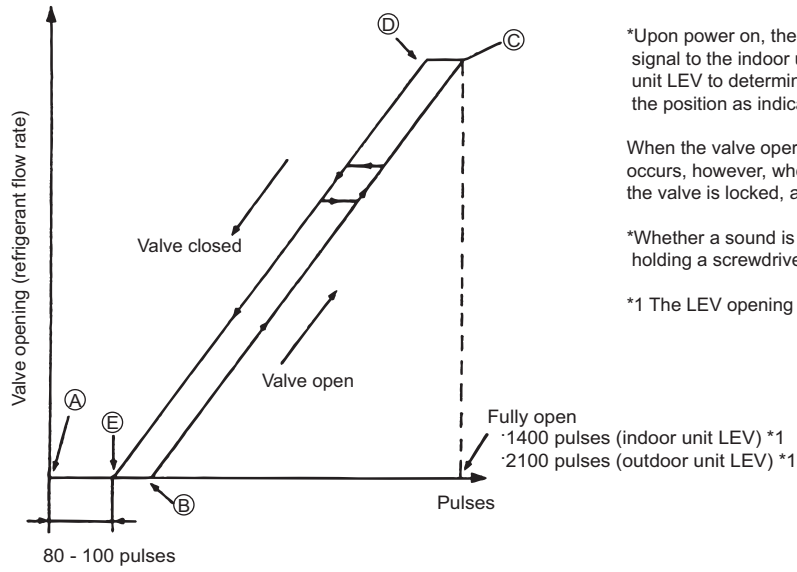

*Upon power on, the indoor unit circuit board sends a 2200 pulse signal to the indoor unit LEV and a 3200 pulse signal to the outdoor unit LEV to determine the valve position and always brings the valve to the position as indicated by "A" in the diagram.

When the valve operates smoothly, no sound from LEV or no vibration occurs, however, when the pulses change from E to A in the chart or the valve is locked, a big sound occurs.

*Whether a sound is generated or not can be determined by holding a screwdriver against it, then placing your ear against the handle.

*1 The LEV opening may become greater depending on the operation status.

(2) Outdoor LEV (LEV1)

The valve opening changes according to the number of pulses.

1) Connections between the outdoor control board and LEV1 (outdoor expansion valve)

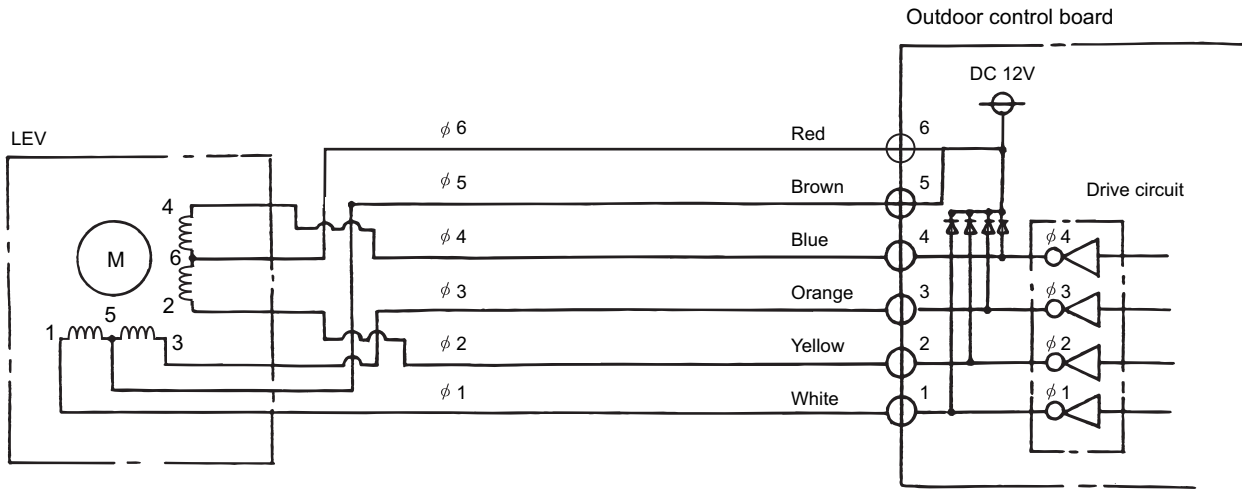

2) Pulse signal output and valve operation

| Output (phase) number | Output state | | | | | | | |
|-----------------------|--------------|-----|-----|-----|-----|-----|-----|-----|
| | 1 | 2 | 3 | 4 | 5 | 6 | 7 | 8 |
| φ 1 | ON | OFF | OFF | OFF | OFF | OFF | ON | ON |
| φ 2 | ON | ON | ON | OFF | OFF | OFF | OFF | OFF |
| φ 3 | OFF | OFF | ON | ON | ON | OFF | OFF | OFF |
| φ 4 | OFF | OFF | OFF | OFF | ON | ON | ON | OFF |

Output pulses change in the following orders when the
 Valve is open; 1 → 2 → 3 → 4 → 5 → 6 → 7 → 8 → 1
 Valve is closed; 8 → 7 → 6 → 5 → 4 → 3 → 2 → 1 → 8

- *1. When the LEV opening angle does not change, all the output phases will be off.
- *2. When the output is open phase or remains ON, the motor cannot run smoothly, and rattles and vibrates.

3) LEV valve closing and opening operation

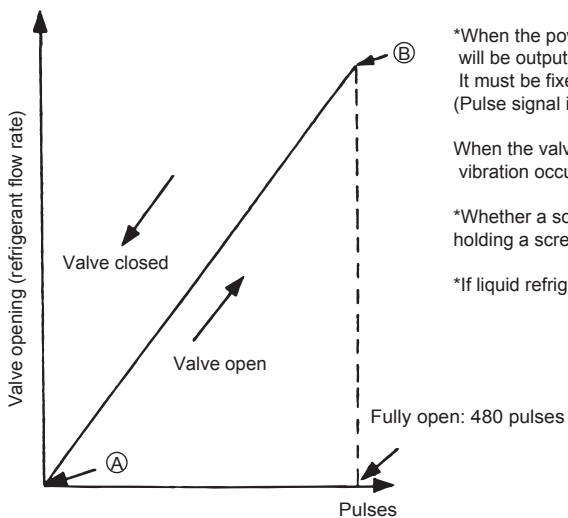

*When the power is turned on, the valve closing signal of 520 pulses will be output from the indoor board to LEV to fix the valve position. It must be fixed at point (A)
 (Pulse signal is output for approximately 17 seconds.)

When the valve operates smoothly, there is no sound from the LEV and no vibration occurs, but when the valve is locked, noise is generated.

*Whether a sound is generated or not can be determined by holding a screwdriver against it, then placing your ear against the handle.

*If liquid refrigerant flows inside the LEV, the sound may become smaller.

(3) Judgment methods and possible failure mode

Note

The specifications of the outdoor unit (outdoor LEV) and the indoor unit (indoor LEV) differ. Therefore, remedies for each failure may vary. Check the remedy specified for the appropriate LEV as indicated in the right column.

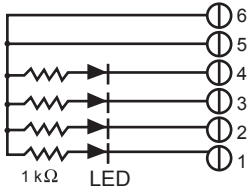
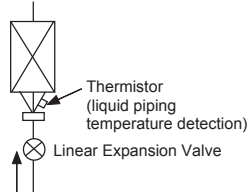
| Malfunction mode | Judgment method | Remedy | Target LEV |
|--|---|--|--------------------------|
| Microcomputer driver circuit failure | <p>Disconnect the control board connector and connect the check LED as shown in the figure below.</p>  <p>resistance : 0.25W 1kΩ LED : DC15V 20mA or more</p> <p>When the main power is turned on, the indoor unit circuit board outputs pulse signals to the indoor unit LEV for 10 seconds, and the outdoor unit circuit board outputs pulse signals to the outdoor unit LEV for 17 seconds.</p> <p>If any of the LED remains lit or unlit, the drive circuit is faulty.</p> | When the drive circuit has a problem, replace the control board. | Indoor Outdoor |
| LEV mechanism is locked | If the LEV is locked, the drive motor runs idle, and makes a small clicking sound. When the valve makes a closing and opening sound, the valve has a problem. | Replace the LEV. | Indoor Outdoor |
| Disconnected or short-circuited LEV motor coil | Measure the resistance between coils (indoor unit LEV: red-white, red-orange, brown-yellow, brown-blue; outdoor unit LEV: red-white, red-orange, red-yellow, red-blue) with a tester, and check that the resistance is in the range of 150 ohm ± 10%. | Replace the LEV coils. | Indoor Outdoor (LEV2) |
| | Measure resistance between the coils (red - white, red -orange, brown - yellow, brown - blue) using a tester. They are normal if resistance is 46 ohm ± 3%. | Replace the LEV coils. | Outdoor (LEV1) |
| Incomplete sealing (leak from the valve) | <p>When checking the refrigerant leak from the indoor LEV, run the target indoor unit in the fan mode, and the other indoor units in the cooling mode. Then, check the liquid temperature (TH22) with the self-diagnosis LED.</p> <p>When the unit is running in the fan mode, the LEV is fully closed, and the temperature detected by the thermistor is not low. If there is a leak, however, the temperature will be low. If the temperature is extremely low compared with the inlet temperature displayed on the remote controller, the LEV is not properly sealed, however, if there is a little leak, it is not necessary to replace the LEV when there are no effects to other parts.</p>  | If there is a large amount of leakage, replace the LEV. | Indoor |
| Faulty wire connections in the connector or faulty contact | <ol style="list-style-type: none"> Check for loose pins on the connector and check the colors of the lead wires visually Disconnect the control board's connector and conduct a continuity check using a tester. | Check the continuity at the points where an error occurs. | Indoor Outdoor |

(4) Outdoor unit LEV (LEV1) coil removal procedure

1) LEV component

As shown in the figure, the outdoor LEV is made in such a way that the coils and the body can be separated.

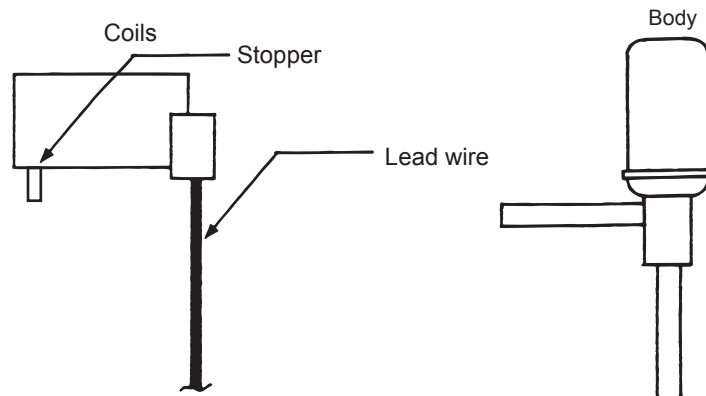

2) Removing the coils

Fasten the body tightly at the bottom (Part A in the figure) so that the body will not move, then pull out the coils toward the top. If the coils are pulled out without the body gripped, undue force will be applied and the pipe will be bent.

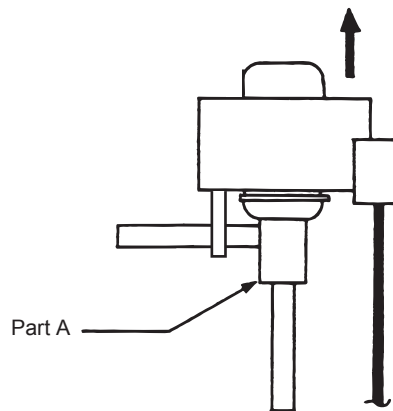

3) Installing the coils

Fix the body tightly at the bottom (Part A in the figure) so that the body will not move, then insert the coils from the top, and insert the coil stopper securely in the pipe on the body. Hold the body when pulling out the coils to prevent so that the pipe will not be bent.

If the coils are pushed without the body gripped, undue force will be applied and the pipe will be bent. Hold the body when pulling out the coils to prevent so that the pipe will not be bent.

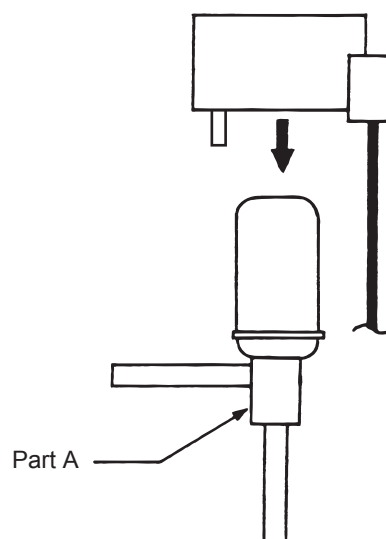

(5) Removal procedure of outdoor unit LEV2 coil

1) Components

The outdoor unit LEV consists of a coil and a valve body that can be separated from each other.

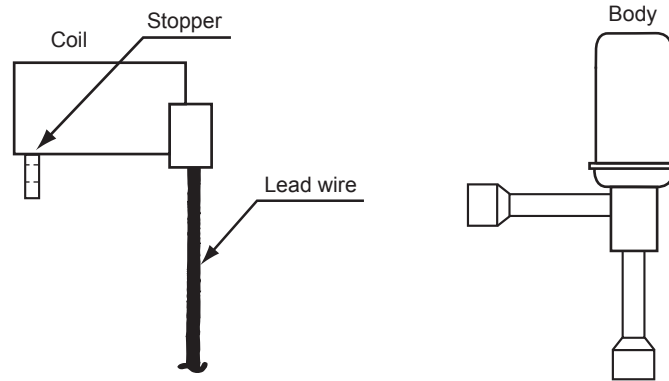

2) Removing the coil

Securely hold the LEV at the bottom (as indicated by A in the figure), and turn the coil. After checking that the stopper is removed, pull up and out the coil. When removing the coil, hold the LEV body securely to prevent undue force from being placed on the pipe and bending the pipe.

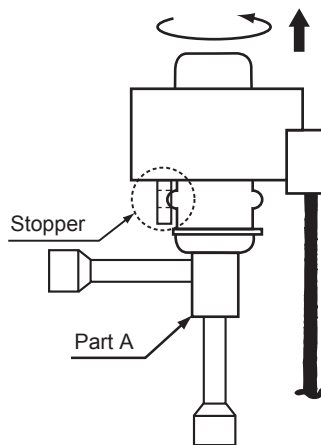

3) Installing the coil

Securely hold the bottom of the LEV (section A in the figure), insert the coil from above, and turn the coil until the coil stopper is properly installed on the LEV body. When removing the coil, hold the LEV body securely to prevent undue force from being placed on the pipe and bending the pipe.

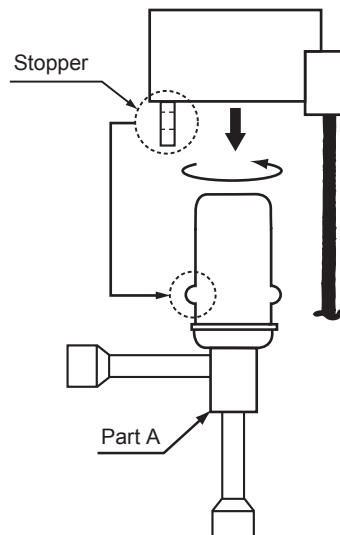

-6- Inverter

- Replace only the compressor if only the compressor is found to be defective.
- Replace only the fan motor if only the fan motor is found to be defective.
- Replace the defective components if the inverter is found to be defective.
- If both the compressor and the inverter are found to be defective, replace the defective component(s) of both devices.

(1) Inverter-related problems: Troubleshooting and remedies

- 1) The INV board has a large-capacity electrolytic capacitor, in which residual voltage remains even after the main power is turned off, posing a risk of electric shock. Before inspecting the inside of the control box, turn off the power, keep the unit off for at least 10 minutes, and confirm that the voltage between FT-P and FT-N on INV Board has dropped to DC20V or less. (It takes about 10 minutes to discharge electricity after the power supply is turn off.)
- 2) The IPM on the inverter becomes damaged if there are loose screws or connectors. If a problem occurs after replacing some of the parts, mixed up wiring is often the cause of the problem. Check for proper connection of the wiring, screws, connectors, and Faston terminals.
- 3) To avoid damage to the circuit board, do not connect or disconnect the inverter-related connectors with the main power turned on.
- 4) Faston terminals have a locking function. Make sure the terminals are securely locked in place after insertion.

Press the tab on the terminals to remove them.

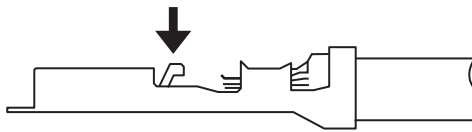

- 5) When the IPM or IGBT is replaced, apply a thin layer of heat radiation grease that is supplied evenly to these parts. Wipe off any grease that may get on the wiring terminal to avoid terminal contact failure.
- 6) Faulty wiring to the compressor damages the compressor. Connect the wiring in the correct phase sequence.

| | Error display/failure condition | Measure/inspection item |
|-----|---|---|
| [1] | Inverter related errors 4250, 4255, 4220, 4225, 4230, 4240, 4260, 5301, 0403 | Check the details of the inverter error in the error log at X LED Monitor Display on the Outdoor Unit Board. Take appropriate measures to the error code and the error details in accordance with IX [2] Responding to Error Display on the Remote Controller. |
| [2] | Main power breaker trip | Refer to "(3) Trouble treatment when the main power breaker is tripped".(page 237) |
| [3] | Main power earth leakage breaker trip | Refer to "(4) Trouble treatment when the main power earth leakage breaker is tripped".(page 237) |
| [4] | Only the compressor does not operate. | Check the inverter frequency on the LED monitor and proceed to (2) - [4] if the compressor is in operation.(page 235) |
| [5] | The compressor vibrates violently at all times or makes an abnormal sound. | See (2)-[4].(page 235) |
| [6] | Only the fan motor does not operate. | Check the inverter frequency on the LED monitor and proceed to (2)-[6] if the fan motor is in operation.(page 236) |
| [7] | The fan motor shakes violently at all times or makes an abnormal sound. | Check the inverter frequency on the LED monitor and proceed to (2)-[6] if the fan motor is in operation.(page 236) |
| [8] | Noise is picked up by the peripheral device | <p><1> Check that power supply wiring of the peripheral device does not run close to the power supply wiring of the outdoor unit.</p> <p><2> Check if the inverter output wiring is not running parallel to the power supply wiring and the transmission lines.</p> <p><3> Check that the shielded wire is used as the transmission line when it is required, and check that the grounding work is performed properly on the shielded wire.</p> <p><4> Meg failure for electrical system other than the inverter</p> <p><5> Attach a ferrite core to the inverter output wiring. (Contact the factory for details of the service part settings.)</p> <p><6> Provide separate power supply to the air conditioner and other electric appliances.</p> <p><7> If the error occurred suddenly, a ground fault of the inverter output can be considered. See (2)-[4].(page 235)</p> <p>*Contact the factory for cases other than those listed above.</p> |
| [9] | Sudden malfunction (as a result of external noise.) | <p><1> Check that the grounding work is performed properly.</p> <p><2> Check that the shielded wire is used as the transmission line when it is required, and check that the grounding work is performed properly on the shielded wire.</p> <p><3> Check that neither the transmission line nor the external connection wiring does not run close to another power supply system or does not run through the same conduit pipe.</p> <p>* Contact the factory for cases other than those listed above.</p> |

(2) Inverter output related troubles

| | Items to be checked | Phenomena | Remedy |
|---|---|---|--|
| [1] Check the INV board error detection circuit. | (1) Disconnect the inverter output wire from the terminals of the INV board (SC-U, SC-V, SC-W). | 1) Overcurrent error (4250 Detail code No. 101, 104, 105, 106, and 107) | Replace the INV board. |
| | | 2) Logic error (4220 Detail code No. 111) | Replace the INV board. |
| | (2) Put the outdoor unit into operation. | 3) ACCT sensor circuit failure (5301 Detail code No.117) | Replace the INV board. |
| | 4) IPM open (5301 Detail code No.119) | Normal | |
| [2] Check for compressor ground fault or coil error. | Disconnect the compressor wiring, and check the compressor Meg, and coil resistance. | 1) Compressor Meg failure Error if less than 1 Mohm. | Check that there is no liquid refrigerant in the compressor. If there is none, replace the compressor. |
| | | 2) Compressor coil resistance failure Coil resistance value of 0.71 ohm (20°C [68°F]): P200 and P250 models Coil resistance value of 0.32 ohm (20°C [68°F]): P300 - P450 models | Replace the compressor. |

| | Items to be checked | Phenomena | Remedy |
|---|---|---|--|
| <p>[3] Check whether the inverter is damaged. (No load)</p> | <p>(1) Disconnect the inverter output wire from the terminals of the INV board (SC-U, SC-V, SC-W).</p> <p>(2) Disconnect the short-circuit connector from CN6 on the INV board.</p> <p>(3) Put the outdoor unit into operation. Check the inverter output voltage after the inverter output frequency has stabilized.</p> | <p>1) Inverter-related problems are detected.</p> | <p>Connect the short-circuit connector to CN6, and go to section [1].</p> |
| | | <p>2) Inverter voltage is not output at the terminals (SC-U, SC-V, and SC-W)</p> | <p>Replace the INV board.</p> |
| | | <p>3) There is a voltage imbalance between the wires. Greater than 5% imbalance or 5V</p> | <p>Replace the INV board.</p> |
| | | <p>4) There is no voltage imbalance between the wires.</p> | <p>Normal *Reconnect the short-circuit connector to CN6 after checking the voltage.</p> |
| <p>[4] Check whether the inverter is damaged. (During compressor operation)</p> | <p>Put the outdoor unit into operation. Check the inverter output voltage after the inverter output frequency has stabilized.</p> | <p>1) Overcurrent-related problems occur immediately after compressor startup. Error code : 4250 Detail code : 101, 106, 107</p> | <p>a. Check items [1] through [3] for problems.</p> <p>b. Check that high and low pressures are balanced.</p> <p>c. Check that no liquid refrigerant is present in the compressor. →Go to "d." when the problem persists after compressor startup was repeated several times. If normal operation is restored, check the crankcase heater for problems.</p> <p>d. Check that there is a pressure difference between high and low pressures after compressor startup. →Check the high pressure with LED monitor for changes. Replace the compressor if there is no pressure difference. (the compressor may be locked.)</p> |
| | | <p>2) There is a voltage imbalance between the wires after the inverter output voltage is stabilized. Greater than the larger of the following values: imbalance of 5% or 5V</p> | <p>Replace the INV board if there is a voltage imbalance. Check the crankcase heater for problems if there is no voltage imbalance. →When the error occurred, liquid refrigerant may have been present in the compressor.</p> |
| <p>[5] Check the fan motor ground fault or the winding.</p> | <p>Remove the wire for the outdoor fan motor, and check the fan motor megger and the winding resistance.</p> | <p>1) Fan motor megger failure Failure when the megger is 1Mohm or less.</p> | <p>Replace the fan motor.</p> |
| | | <p>2) Fan motor disconnection Standard: The winding resistance is approximately several ohm. (It varies depending on the temperature, or while the inner thermo is operating, it will be ∞ ohm)</p> | |

| | Items to be checked | Phenomena | Remedy |
|--|--|---|------------------------|
| [6] Check the fan inverter board failure. | (1) Check the fan output wiring. | Connector contact failure •Board side (CNINV) •Fan motor side | Connect the connector. |
| | (2) Check the connector CN-VDC connection. | Cnnector contact failure | Connect the connector. |
| | (3) Check the FAN board failure. | 1) The voltage imbalance among each motor wiring during operation (The voltage imbalance is greater than the larger of the values represented by 5% or 5V.) | Replace the FAN board. |
| | | 2) The same error occurs even after the operation is restarted. | |

(3) Trouble treatment when the main power breaker is tripped

| | Items to be checked | Phenomena | Remedy |
|-----|--|---|---|
| [1] | Check the breaker capacity. | Use of a non-specified breaker | Replace it with a specified breaker. |
| [2] | Perform Meg check between the terminals on the power terminal block TB1. | Zero to several ohm, or Meg failure | Check each part and wiring. *Refer to (5) "Simple checking Procedures for individual components of main inverter circuit".(page 238) ♦IGBT module ♦Rush current protection resistor ♦Electromagnetic relay ♦DC reactor |
| [3] | Turn on the power again and check again. | 1) Main power breaker trip 2) No remote control display | ♦IGBT module ♦Rush current protection resistor ♦Electromagnetic relay ♦DC reactor |
| [4] | Turn on the outdoor unit and check that it operates normally. | 1) Operates normally without tripping the main breaker. 2) Main power breaker trip | a) The wiring may have been short-circuited. Search for the wire that short-circuited, and repair it. b) If item a) above is not the cause of the problem, refer to (2)-[1]-[6]. |

(4) Trouble treatment when the main power earth leakage breaker is tripped

| | Items to be checked | Phenomena | Remedy |
|-----|---|---|---|
| [1] | Check the earth leakage breaker capacity and the sensitivity current. | Use of a non-specified earth leakage breaker | Replace with a regulation earth leakage breaker. |
| [2] | Check the resistance at the power supply terminal block with a megger. | Failure resistance value | Check each part and wiring. *Refer to (5) "Simple checking Procedures for individual components of main inverter circuit".(page 238) ♦IGBT module ♦Rush current protection resistor ♦Electromagnetic relay ♦DC reactor |
| [3] | Disconnect the compressor wirings and check the resistance of the compressor with a megger. | Failure compressor if the insulating resistance value is not in specified range. Failure when the insulating resistance value is 1 Mohm or less. | Check that there is no liquid refrigerant in the compressor. If there is none, replace the compressor. |
| [4] | Disconnect the fan motor wirings and check the resistance of the fan motor with a megger. | Failure fan motor if the insulating resistance value is not in specified range. Failure when the insulating resistance value is 1 Mohm or less. | Replace the fan motor. |

Note

The insulation resistance could go down to close to 1Mohm after installation or when the power is kept off for an extended period of time because of the accumulation of refrigerant in the compressor. If the earth leakage breaker is triggered, please use the following procedure to take care of this.

- ♦Disconnect the wires from the compressor's terminal block.
- ♦If the resistance is less than 1 Mohm, switch on the power for the outdoor unit with the wires still disconnected.
- ♦Leave the power on for at least 12 hours.
- ♦Check that the resistance has recovered to 1 Mohm or greater.

Earth leakage current measurement method

- ♦For easy on-site measurement of the earth leakage current, enable the filter with a measurement instrument that has filter functions as below, clamp all the power supply wires, and measure.
- Recommended measurement instrument: CLAMP ON LEAK HiTESTER 3283 made by HIOKI E.E. CORPORATION
- ♦When measuring one device alone, measure near the device's power supply terminal block.

(5) Simple checking procedure for individual components of main inverter circuit

Note

Before inspecting the inside of the control box, turn off the power, keep the unit off for at least 10 minutes, and confirm that the voltage between FT-P and FT-N on INV Board has dropped to DC20V or less.

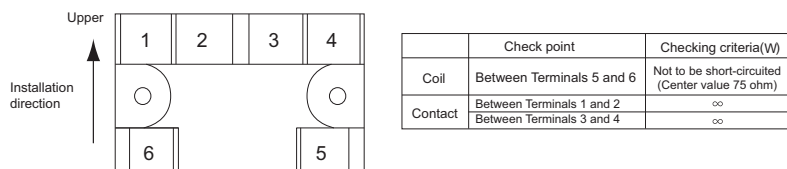
| Part name | Judgment method | | | | | | | | | | | | | |
|---|--|---|-------------|----------------------|------|---------------------------|---|---------------------------|----------|---------|---------------------------|----------|---------------------------|----------|
| IGBT module | See "Troubleshooting for IGBT Module ". (IX [4] - 6 - (6))(page 238) | | | | | | | | | | | | | |
| Rush current protection resistor R1, R5 | Measure the resistance between terminals R1 and R5: 22 ohm \pm 10% | | | | | | | | | | | | | |
| Electromagnetic relay 72C | <p>Note</p> <p>This electromagnetic relay is rated at DC12V and is driven by a coil. Check the resistance between terminals</p>  <p>The diagram shows a relay with terminals 1, 2, 3, 4 on the top row and 6, 5 on the bottom row. Terminals 1 and 6 are connected to a coil, and terminals 2, 3, 4, and 5 are connected to contacts. An arrow labeled 'Installation direction' points upwards. To the right is a table:</p> <table border="1"> <thead> <tr> <th></th> <th>Check point</th> <th>Checking criteria(W)</th> </tr> </thead> <tbody> <tr> <td rowspan="2">Coil</td> <td>Between Terminals 5 and 6</td> <td>Not to be short-circuited (Center value 75 ohm)</td> </tr> <tr> <td>Between Terminals 1 and 2</td> <td>∞</td> </tr> <tr> <td rowspan="2">Contact</td> <td>Between Terminals 1 and 2</td> <td>∞</td> </tr> <tr> <td>Between Terminals 3 and 4</td> <td>∞</td> </tr> </tbody> </table> | | Check point | Checking criteria(W) | Coil | Between Terminals 5 and 6 | Not to be short-circuited (Center value 75 ohm) | Between Terminals 1 and 2 | ∞ | Contact | Between Terminals 1 and 2 | ∞ | Between Terminals 3 and 4 | ∞ |
| | Check point | Checking criteria(W) | | | | | | | | | | | | |
| Coil | Between Terminals 5 and 6 | Not to be short-circuited (Center value 75 ohm) | | | | | | | | | | | | |
| | Between Terminals 1 and 2 | ∞ | | | | | | | | | | | | |
| Contact | Between Terminals 1 and 2 | ∞ | | | | | | | | | | | | |
| | Between Terminals 3 and 4 | ∞ | | | | | | | | | | | | |
| DC reactor DCL | Measure the resistance between terminals: 1ohm or lower (almost 0 ohm) Measure the resistance between terminals and the chassis: ∞ | | | | | | | | | | | | | |

(6) Troubleshooting for IGBT Module

Measure the resistances between each pair of terminals on the IGBT with a tester, and use the results for troubleshooting. The terminals on the INV board are used for the measurement.

1) Notes on measurement

- Check the polarity before measuring. (On the tester, black normally indicates plus.)
- Check that the resistance is not open (∞ ohm) or not shorted (to 0 ohm).
- The values are for reference, and the margin of errors is allowed.
- The result that is more than double or half of the result that is measured at the same measurement point is not allowed.
- Disconnect all the wiring connected the INV board, and make the measurement.

2) Tester restriction

- Use the tester whose internal electrical power source is 1.5V or greater
- Use the dry-battery-powered tester.

Note

(The accurate diode-specific resistance cannot be measured with the button-battery-powered card tester, as the applied voltage is low.)

- Use a low-range tester if possible. A more accurate resistance can be measured.

Judgment value (reference)

| | | Black (+) | | | | |
|---------|-------|-----------|-------------|-------------|-------------|-------------|
| | | SC-P1 | FT-N | SC-L1 | SC-L2 | SC-L3 |
| Red (-) | SC-P1 | - | - | 5 - 200 ohm | 5 - 200 ohm | 5 - 200 ohm |
| | FT-N | - | - | ∞ | ∞ | ∞ |
| | SC-L1 | ∞ | 5 - 200 ohm | - | - | - |
| | SC-L2 | ∞ | 5 - 200 ohm | - | - | - |
| | SC-L3 | ∞ | 5 - 200 ohm | - | - | - |

| | | Black (+) | | | | |
|---------|-------|-----------|-------------|-------------|-------------|-------------|
| | | SC-P2 | FT-N | SC-U | SC-V | SC-W |
| Red (-) | SC-P2 | - | - | 5 - 200 ohm | 5 - 200 ohm | 5 - 200 ohm |
| | FT-N | - | - | ∞ | ∞ | ∞ |
| | SC-U | ∞ | 5 - 200 ohm | - | - | - |
| | SC-V | ∞ | 5 - 200 ohm | - | - | - |
| | SC-W | ∞ | 5 - 200 ohm | - | - | - |

INV board external diagram

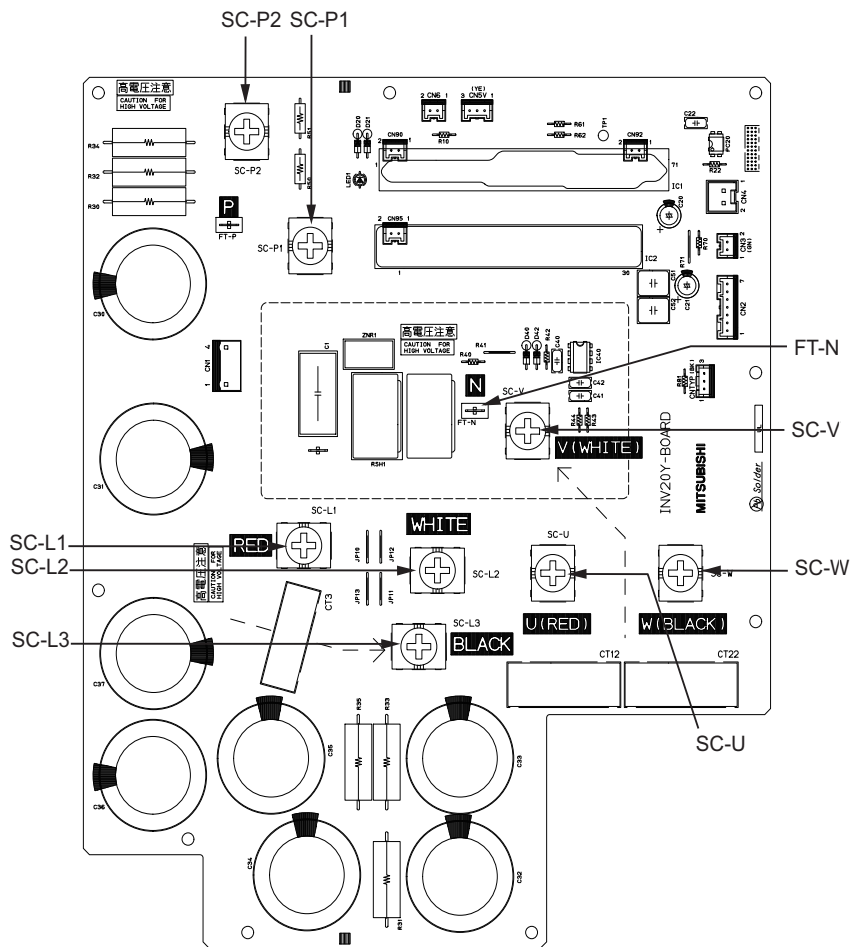

-7- Control Circuit

(1) Control power source function block

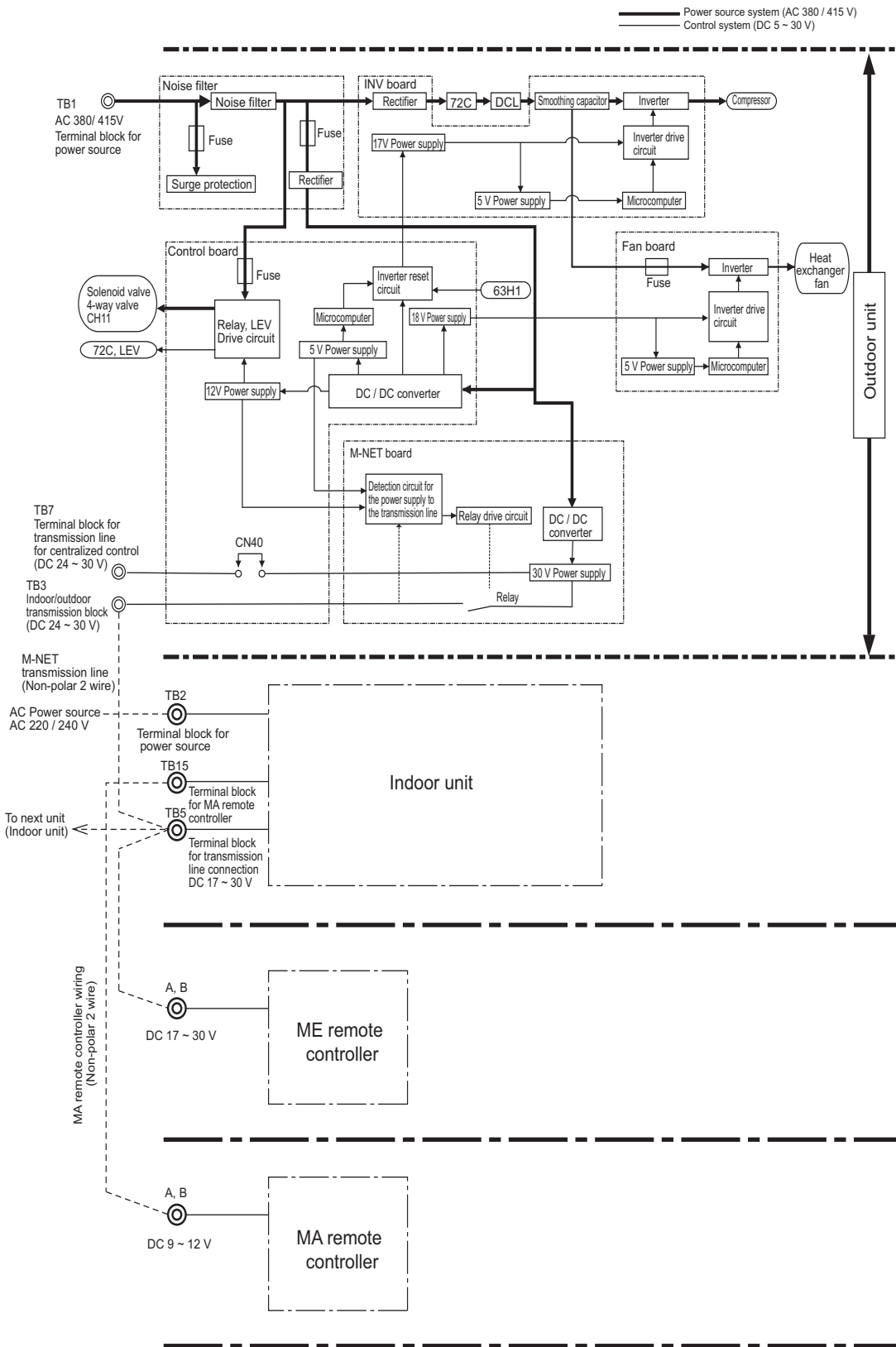

* MA remote controllers and ME remote controllers cannot be used together.
 (Both the ME and MA remote controller can be connected to a system with a system controller.)

(2) Troubleshooting transmission power circuit of outdoor unit

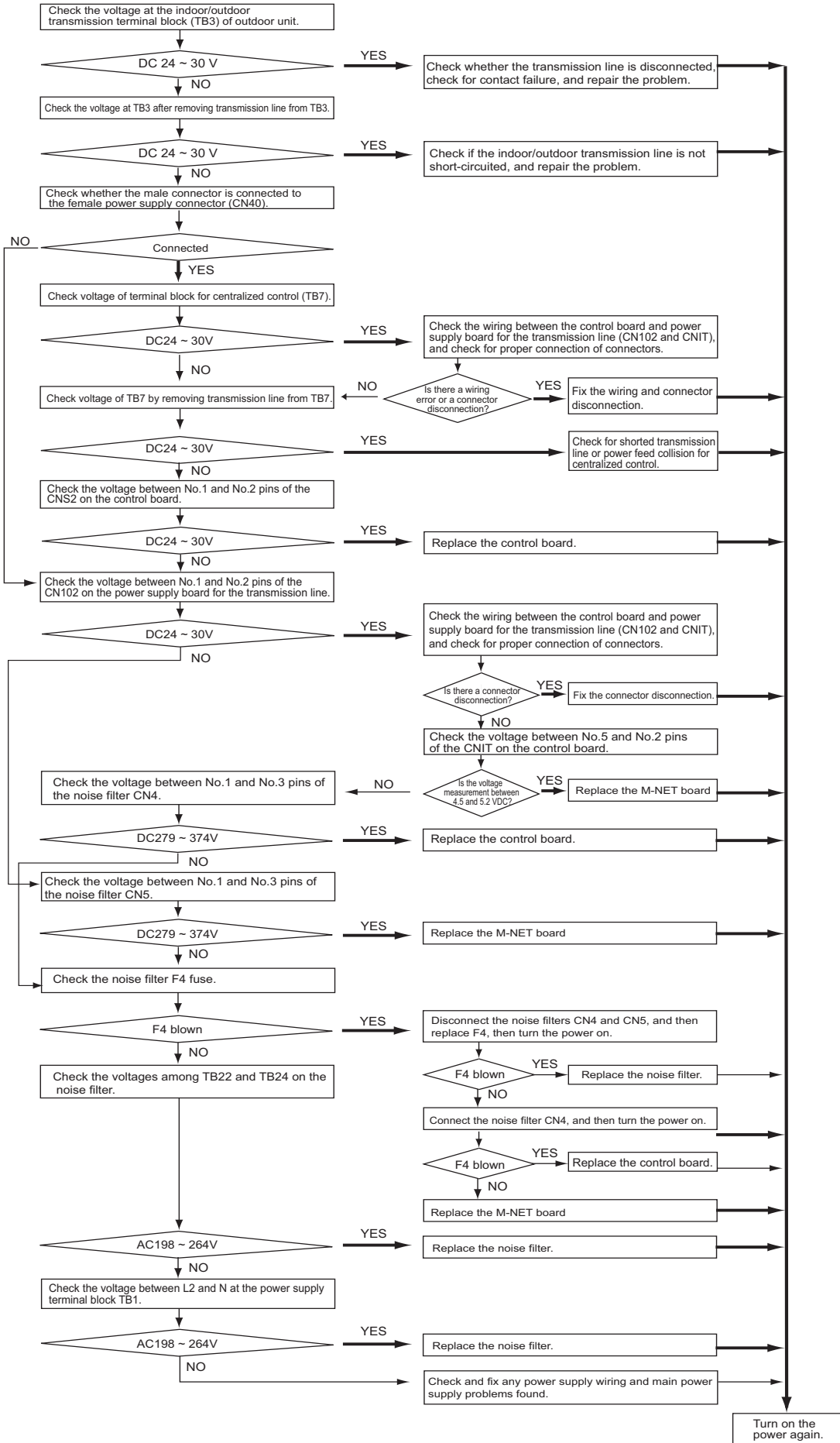

[5] Refrigerant Leak

1. Leak spot: In the case of extension pipe for indoor unit (Cooling season)

- 1) Mount a pressure gauge on the service check joint (CJ2) on the low-pressure side.
- 2) Stop all the indoor units, and close the liquid service valve (BV2) inside the outdoor unit while the compressor is being stopped.
- 3) Stop all the indoor units; turn on SW2-4 on the outdoor unit control board while the compressor is being stopped. (Pump down mode will start, and all the indoor units will run in cooling test run mode.)
- 4) In the pump down mode (SW2-4 is ON), all the indoor units will automatically stop when the low pressure (63LS) reaches 0.383MPa [55psi] or less or 15 minutes have passed after the pump mode started. Stop all the indoor units and compressors when the pressure indicated by the pressure gauge, which is on the check joint (CJ2) for low-pressure service, reaches 0.383MPa [55psi] or 20 minutes pass after the pump down operation is started.
- 5) Close the gas service valve (BV1) inside the outdoor unit.
- 6) Collect the refrigerant that remains in the extended pipe for the indoor unit. Do not discharge refrigerant into the atmosphere when it is collected.
- 7) Repair the leak.
- 8) After repairing the leak, vacuum the extension pipe and the indoor unit.
- 9) To adjust refrigerant amount, open the service valves (BV1 and BV2) inside the outdoor unit and turn off SW2-4.

2. Leak spot: In the case of outdoor unit (Cooling season)

(1) Run all the indoor units in the cooling test run mode.

- 1) To run the indoor unit in test run mode, turn SW3-2 from ON to OFF when SW3-1 on the outdoor control board is ON.
- 2) Change the setting of the remote controller for all the indoor units to the cooling mode.
- 3) Check that all the indoor units are performing a cooling operation.

(2) Check the values of Tc and TH6.

(To display the values on the LED screen, use the self-diagnosis switch (SW1) on the outdoor unit control board.)

- 1) When Tc-TH6 is 10°C [18°F] or more : See the next item (3).
- 2) When Tc-TH6 is less than 10°C [18°F] : After the compressor stops, collect the refrigerant inside the system, repair the leak, perform evacuation, and recharge new refrigerant. (Leak spot: 4. In the case of outdoor unit, handle in the same way as heating season.)

Tc self-diagnosis switch

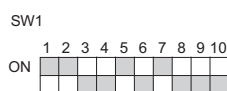

TH6 self-diagnosis switch

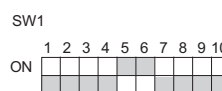

(3) Stop all the indoor units, and stop the compressor.

- 1) To stop all the indoor units and the compressors, turn SW3-2 from ON to OFF when SW3-1 on the outdoor control board is ON.
- 2) Check that all the indoor units are being stopped.

(4) Close the service valves (BV1 and BV2).

(5) To prevent the liquid seal, extract small amount of refrigerant from the check joint of the liquid service valve (BV2), as the liquid seal may cause a malfunction of the unit.

(6) Collect the refrigerant that remains inside the outdoor unit. Do not discharge refrigerant into air into the atmosphere when it is collected.

(7) Repair the leak.

(8) After repairing the leak, replace the dryer with the new one, and perform evacuation inside the outdoor unit.

(9) To adjust refrigerant amount, open the service valves (BV1 and BV2) inside the outdoor unit.

Note

When the power to the outdoor/indoor unit must be turned off to repair the leak after closing the service valves specified in the item 4, turn the power off in approximately one hour after the outdoor/indoor units stop.

- 1) When 30 minutes have passed after the item 4 above, the indoor unit lev turns from fully closed to slightly open to prevent the refrigerant seal.

LEV2 opens when the outdoor unit remains stopped for 15 minutes to allow for the collection of refrigerant in the outdoor unit heat exchanger and to enable the evacuation of the outdoor unit heat exchanger.

If the power is turned off in less than 15 minutes, LEV2 may close, trapping high-pressure refrigerant in the outdoor unit heat exchanger and creating a highly dangerous situation.

- 2) Therefore, if the power source is turned off within 30 minutes, the lev remains fully closed and the refrigerant remains sealed. When only the power for the indoor unit is turned off, the indoor unit LEV turns from faintly open to fully closed.
- 3) In the cooling cycle, the section between 21S4b and LEV2 will form a closed circuit. To recover the refrigerant or evacuate the system, open LEV1 by setting SW5-8 to ON in the stop mode. Upon completion of all work, set SW5-8 to OFF.

3. Leak spot: In the case of extension pipe for indoor unit (Heating season)

(1) Run all the indoor units in heating test run mode.

- 1) To run the indoor unit in test run mode, turn SW3-2 from ON to OFF when SW3-1 on the outdoor control board is ON.
- 2) Change the setting of the remote controller for all the indoor units to the heating mode.
- 3) Check that all the indoor units are performing a heating operation.

(2) Stop all the indoor units, and stop the compressor.

- 1) To stop all the indoor units and the compressors, turn SW3-2 from ON to OFF when SW3-1 on the outdoor control board is ON.
- 2) Check that all the indoor units are stopped.

(3) Close the service valves (BV1 and BV2).

(4) Collect the refrigerant that remains inside the indoor unit. Do not discharge refrigerant into air into the atmosphere when it is collected.

(5) Repair the leak.

(6) After repairing the leak, perform evacuation of the extension pipe for the indoor unit, and open the service valves (BV1 and BV2) to adjust refrigerant.

4. Leak spot: In the case of outdoor unit (Heating season)

- 1) Collect the refrigerant in the entire system (outdoor unit, extended pipe and indoor unit). Do not discharge refrigerant into the atmosphere when it is collected.
- 2) Repair the leak.
- 3) After repairing the leak, replace the dryer with the new one, and perform evacuation of the entire system, and calculate the standard amount of refrigerant to be added (for outdoor unit, extended pipe and indoor unit), and charge the refrigerant. Refer to "VIII [4] 3." (page 110)

Note

If the indoor or outdoor units need to be turned off for repairing leaks during Step 1) above, turn off the power approximately 1 hour after the units came to a stop.

LEV2 opens when the outdoor unit remains stopped for 15 minutes to allow for the collection of refrigerant in the outdoor unit heat exchanger and to enable the evacuation of the outdoor unit heat exchanger.

If the power is turned off in less than 15 minutes, LEV2 may close, trapping high-pressure refrigerant in the outdoor unit heat exchanger and creating a highly dangerous situation.

[6] Compressor Replacement Instructions

[Compressor replacement procedures]

Follow the procedures below (Steps 1 through 6) to remove the compressor components and replace the compressor. Reassemble them in the reverse order after replacing the compressor.

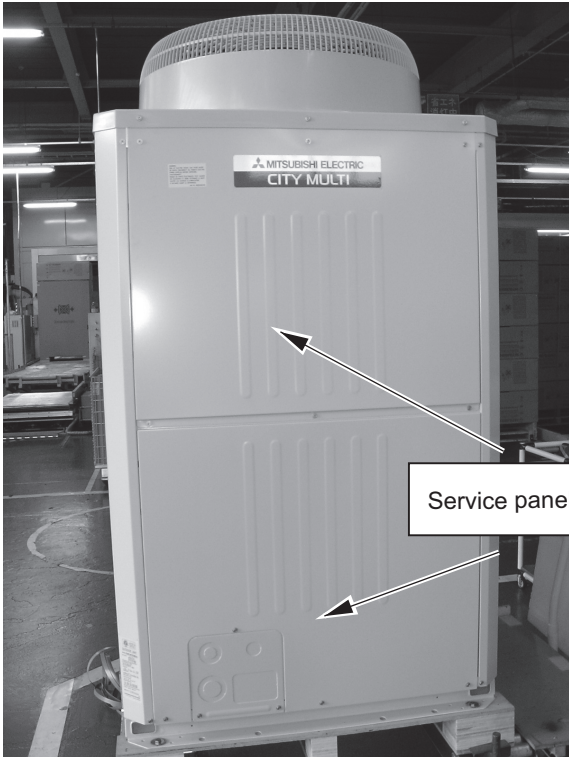

Service panel

1. Remove both the top and bottom service panels (front panels).

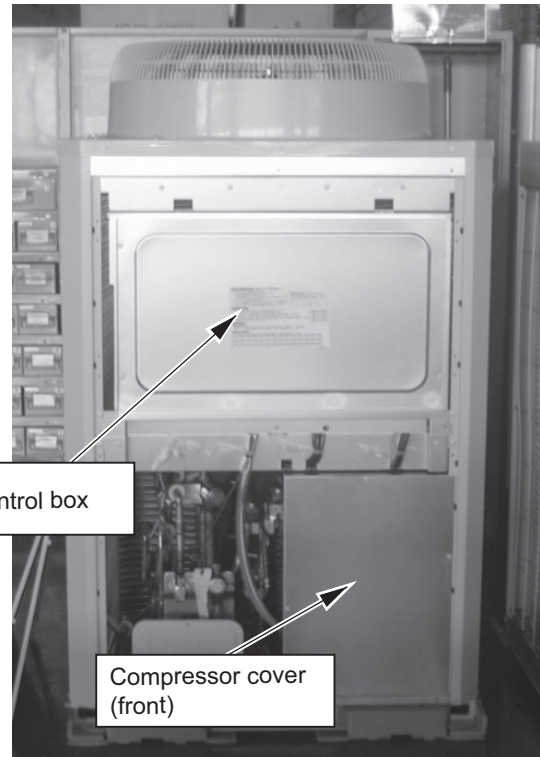

Control box

Compressor cover (front)

2. Remove the control box and the compressor cover (front).

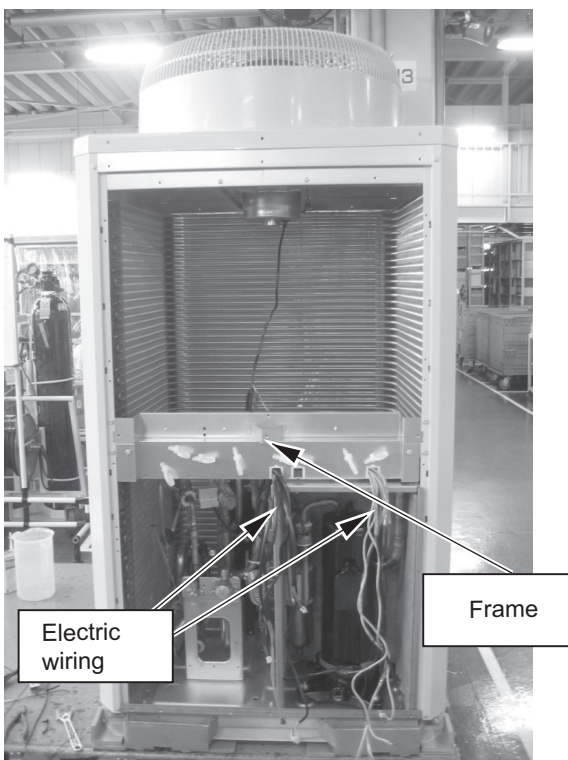

Electric wiring

Frame

3. Remove the wires that are secured to the frame, and remove the frame.



4. Remove the compressor cover (top).

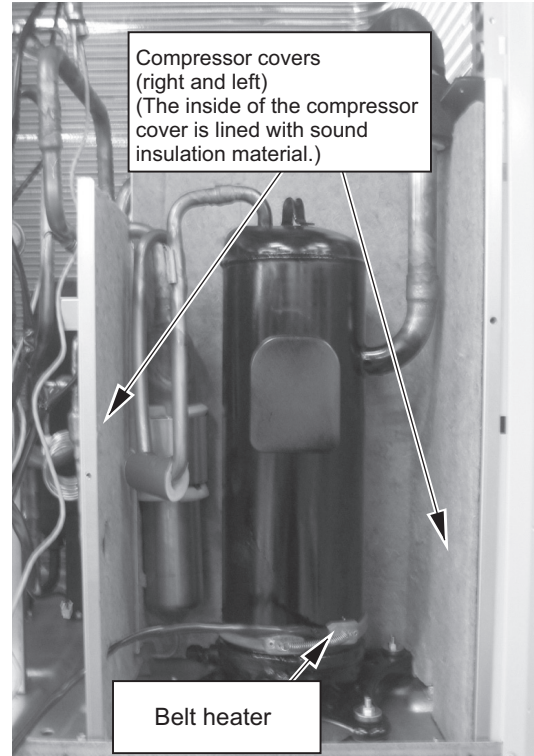

5. Remove the compressor wires, compressor covers (right and left), and belt heater.

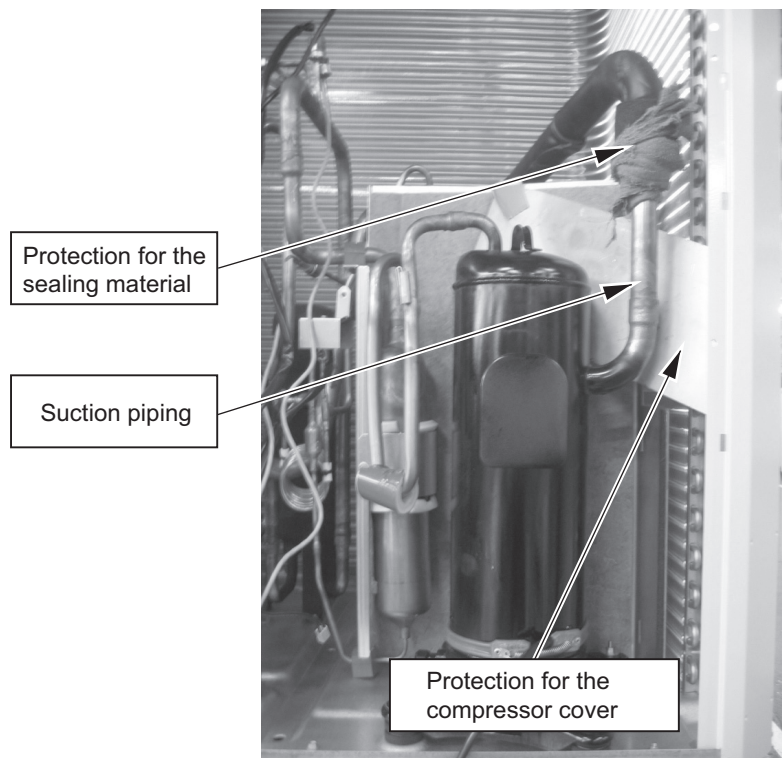

6. Place protective materials on the insulation lining of the compressor cover and on the sealing material on the compressor suction pipe to protect them from the torch flame, debraze the pipe, and replace the compressor.

[7] Troubleshooting Using the Outdoor Unit LED Error Display

If the LED error display appear as follows while all the SW1 switches are set to OFF, check the items under the applicable item numbers below.

1. Error code appears on the LED display.

Refer to IX [2] Responding to Error Display on the Remote Controller.

2. LED is blank.

Take the following troubleshooting steps.

- (1) If the voltage between pins 1 and 3 of CNDC on the control board is outside the range between 220 VDC and 380 VDC, refer to IX [4] -7- (2) Troubleshooting transmission power circuit of outdoor unit.**
- (2) If the LED error display becomes lit when the power is turned on with all the connectors on the control board except CNDC disconnected, there is a problem with the wiring to those connectors or with the connectors themselves.**
- (3) If nothing appears on the display under item (2) above AND the voltage between pins 1 and 3 of CNDC is within the range between 220 VDC and 380 VDC, control board failure is suspected.**

3. Only the software version appears on the LED display.

(1) Only the software version appears while the transmission cables to TB3 and TB7 are disconnected.

- 1) Wiring failure between the control board and the transmission line power supply board.(CNIT, CNS2, CN102)
- 2) If item 1) checks out OK, the transmission line power supply board failure is suspected.
- 3) If items 1) and 2) check out OK, control board failure is suspected.

(2) If the LED display appears as noted in "X [1] 2. LED display at Initial setting"(page 249) while the transmission cables to TB3 and TB7 are disconnected, failure with the transmission cable or the connected equipment is suspected.

X LED Monitor Display on the Outdoor Unit Board

| | |
|--|-----|
| [1] How to Read the LED on the Service Monitor | 249 |
|--|-----|



[1] How to Read the LED on the Service Monitor

1. How to read the LED

By setting the DIP SW 1-1 through 1-10 (Switch number 10 is represented by 0), the operating condition of the unit can be monitored on the service monitor. (Refer to the table on the following pages for DIP SW settings.)
 The service monitor uses 4-digit 7-segment LED to display numerical values and other types of information.

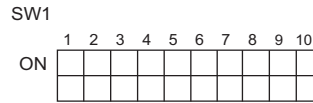
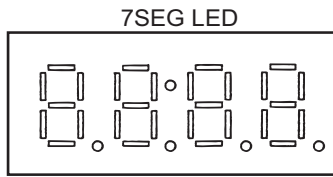

SW1-10 is represented as "0" in the table.

Pressure and temperature are examples of numerical values, and operating conditions and the on-off status of solenoid valve are examples of flag display.

1) Display of numerical values

Example: When the pressure data sensor reads 18.8kg/cm² (Item No. 58)

- The unit of pressure is in kg/cm²
 - Use the following conversion formula to convert the displayed value into a value in SI unit.
- Value in SI unit (MPa) = Displayed value (kg/cm²) x 0.098

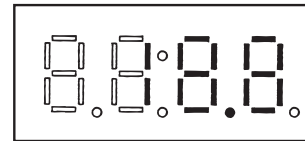

2) Flag display

Example: When 21S4a, 21S4b, SV1a are ON. (Item No. 3)

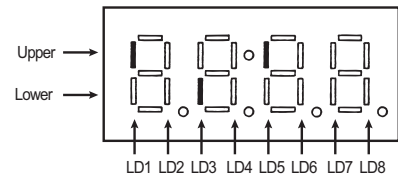

Example: 3-minutes restart mode (Item No. 14)

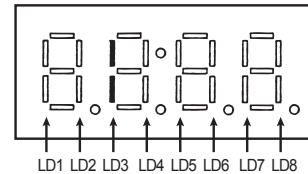

2. LED display at initial setting

From power on until the completion of initial settings, the following information will be displayed on the monitor screen. (Displays No. 1 through No. 4 in order repeatedly.)

| No | Item | Display | Remarks |
|----|-----------------------|---------|---|
| 1 | Software version | | [0103] : Version 1.03 |
| 2 | Refrigerant type | | [410] : R410A |
| 3 | Model and capacity | | [H-20] : Cooling/Heating 20 HP For the first few minutes after power on, the capacity of each outdoor unit is displayed. Thereafter, the combined capacity is displayed. |
| 4 | Communication address | | [51] : Address 51 |

After the initial settings have been completed, the information on these items can be checked by making the switch setting that corresponds to No. 517 in the LED display table.

Note

Only item No. 1 "Software Version" appears on the display if there is a wiring failure between the control board and the transmission line power supply board or if the circuit board has failed.

3. Time data storage function

The outdoor unit has a simple clock function that enables the unit to calculate the current time with an internal timer by receiving the time set by the system controller, such as G(B)-50A.

If an error (including a preliminary error) occurs, the error history data and the error detection time are stored into the service memory.

The error detection time stored in the service memory and the current time can be seen on the service LED.

Note

- 1) Use the time displayed on the service LED as a reference.
- 2) The date and the time are set to "00" by default. If a system controller that sets the time, such as G(B)-50A is not connected, the elapsed time and days since the first power on will be displayed. If the time set on a system controller is received, the count will start from the set date and the time.
- 3) The time is not updated while the power of the indoor unit is turned off. When the power is turned off and then on again, the count will resume from the time before the power was turned off. Thus, the time that differs the actual time will be displayed. (This also applies when a power failure occurs.)
The system controller, such as G(B)-50A, adjusts the time once a day. When the system controller is connected, the time will be automatically updated to the correct current time after the time set by the system controller is received. (The data stored into the memory before the set time is received will not be updated.)

(1) Reading the time data:

- 1) Time display
Example: 12 past 9

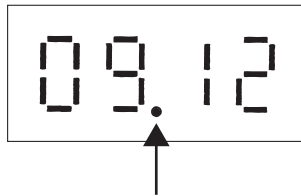

* Disappears if the time data is deviated due to a power failure, or if a system controller that sets the time is not connected.

- 2) Date display
•When the main controller that can set the time is connected
Example: May 10, 2003

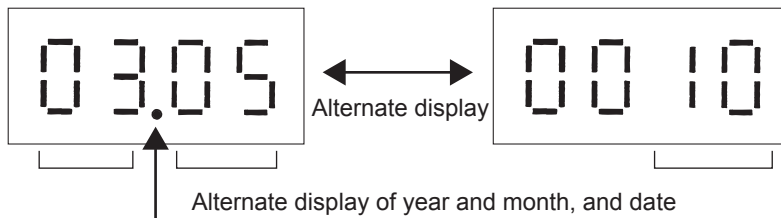

* Appears between the year and the month, and nothing appears when the date is displayed.

- When the main controller that can set the time is not connected
Example: 52 days after power was turned on

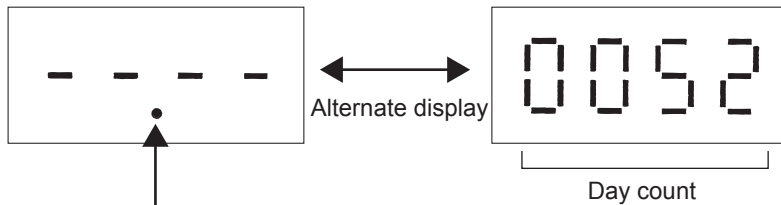

* Appears between the year and the month, and nothing appears when the date is displayed.

**LED monitor display
Current data**

| No. | SW1 1234567890 | Item | Display | | | | | | | | Unit (A, B) *1 | | Remarks | | |
|-----|-------------------|--|--|-----|-------|-----|-----|------|------|-----|-------------------|----|---------|---|---|
| | | | LD1 | LD2 | LD3 | LD4 | LD5 | LD6 | LD7 | LD8 | OC | OS | | | |
| 0 | 0000000000 | Relay output display 1 Lighting | | | | | | | | | | | A | A | |
| | | Check (error) display 1 OC/OS error | 0000 to 9999 (Address and error codes highlighted) | | | | | | | | | | | | |
| 1 | 1000000000 | Check (error) display 2 OC/OS error | 0000 to 9999 (Address and error codes highlighted) | | | | | | | | | | | | |
| 2 | 0100000000 | Check (error) display 3 (Including IC and BC) | 0000 to 9999 (Address and error codes highlighted) | | | | | | | | | | | | |
| 3 | 1100000000 | Relay output display 2 Top | | | CH11 | | | | SV1a | | | | | | |
| | | Bottom | | | 21S4b | | | SV5b | | | | | | A | A |
| 4 | 0010000000 | Relay output display 3 Top | | | | | | | | | SV9 | | | | |
| | | Bottom | | | | | | | | | | | | A | A |
| 5 | 1010000000 | | | | | | | | | | | | | | |
| 6 | 0110000000 | | | | | | | | | | | | | | |
| 7 | 1110000000 | Special control | Retry operation | | | | | | | | | | | | |
| | | | Emergency operation | | | | | | | | | | | | B |
| 8 | 0001000000 | | | | | | | | | | | | | | |
| 9 | 1001000000 | Communication demand capacity | 0000 to 9999 | | | | | | | | | | | | |
| | | | | | | | | | | | | | | | B |
| 10 | 0101000000 | Contact point demand capacity | 0000 to 9999 | | | | | | | | | | | | |
| | | | | | | | | | | | | | | | B |

*1 A: The condition of either OC or OS is displayed individually. B: The condition of the entire refrigerant system is displayed.

| No. | SW1 | Item | Display | | | | | | | | | | Unit ^{*1} (A, B) ^{*1} | | Remarks | |
|-----|------------|---|----------------------|-------------------------------------|------------------------|--------------------------------------|--------------------------------------|-------------|---|-------------|-------------|----|--|---|---------|---|
| | | | LD1 | LD2 | LD3 | LD4 | LD5 | LD6 | LD7 | LD8 | OC | OS | | | | |
| 11 | 1234567890 | External signal (Open input contact point) | Contact point demand | Low-noise mode (Capacity priority) | Snow sensor | Cooling-heating changeover (Cooling) | Cooling-heating changeover (Heating) | | | | | | | A | A | |
| 12 | 0011000000 | External signal (Open input contact point) | | | | | | | | | | | Low-noise mode (Quiet priority) | A | A | |
| 13 | 1011000000 | | | | | | | | | | | | | | | |
| 14 | 0111000000 | Outdoor unit operation status | | | 3-minutes restart mode | Compressor in operation | Preliminary error | Error | 3-minutes restart after instantaneous power failure | | | | Preliminary low pressure error | A | A | |
| 15 | 1111000000 | OC/OS identification | | | | | | | | | | | | A | A | |
| 16 | 0000100000 | Indoor unit check | Top | Unit No. 1 | Unit No. 2 | Unit No. 3 | Unit No. 4 | Unit No. 5 | Unit No. 6 | Unit No. 7 | Unit No. 8 | | | | | The lamp that corresponds to the unit that came to an abnormal stop lights. The lamp goes off when the error is reset. Each unit that comes to an abnormal unit will be given a sequential number in ascending order starting with 1. |
| 17 | 1000100000 | | Bottom | Unit No. 9 | Unit No. 10 | Unit No. 11 | Unit No. 12 | Unit No. 13 | Unit No. 14 | Unit No. 15 | Unit No. 16 | | | | | |
| 18 | 0100100000 | Indoor unit Operation mode | Top | Unit No. 17 | Unit No. 18 | Unit No. 19 | Unit No. 20 | Unit No. 21 | Unit No. 22 | Unit No. 23 | Unit No. 24 | | | | | Lit during cooling Lit during heating Unit while the unit is stopped or in the fan mode |
| 19 | 1100100000 | | Bottom | Unit No. 25 | Unit No. 26 | Unit No. 27 | Unit No. 28 | Unit No. 29 | Unit No. 30 | Unit No. 31 | Unit No. 32 | | | | | |
| 20 | 0010100000 | Indoor unit Operation mode | Top | Unit No. 33 | Unit No. 34 | Unit No. 35 | Unit No. 36 | Unit No. 37 | Unit No. 38 | Unit No. 39 | Unit No. 40 | | | | | Lit during cooling Lit during heating Unit while the unit is stopped or in the fan mode |
| 21 | 1010100000 | | Bottom | Unit No. 41 | Unit No. 42 | Unit No. 43 | Unit No. 44 | Unit No. 45 | Unit No. 46 | Unit No. 47 | Unit No. 48 | | | | | |
| 22 | 0110100000 | Indoor unit Operation mode | Top | Unit No. 49 | Unit No. 50 | | | | | | | | | | | Lit during cooling Lit during heating Unit while the unit is stopped or in the fan mode |
| 23 | 1110100000 | | Bottom | Unit No. 1 | Unit No. 2 | Unit No. 3 | Unit No. 4 | Unit No. 5 | Unit No. 6 | Unit No. 7 | Unit No. 8 | | | | | |

*1 A: The condition of either OC or OS is displayed individually. B: The condition of the entire refrigerant system is displayed.

| No. | SW1 | Item | Display | | | | | | | | | | Unit**1 | | Remarks |
|-----|------------|-----------------------------|------------------|----------------------|---------------|-------------------|------------------|-------------|-------------|----------------------------|----|--|---------|--|---------|
| | | | LD1 | LD2 | LD3 | LD4 | LD5 | LD6 | LD7 | LD8 | OC | OS | | | |
| 24 | 0001100000 | Indoor unit thermostat | Unit No. 1 | Unit No. 2 | Unit No. 3 | Unit No. 4 | Unit No. 5 | Unit No. 6 | Unit No. 7 | Unit No. 8 | B | Lit when thermostat is on Unit when thermostat is off | | | |
| | 1234567890 | | Unit No. 9 | Unit No. 10 | Unit No. 11 | Unit No. 12 | Unit No. 13 | Unit No. 14 | Unit No. 15 | Unit No. 16 | | | | | |
| 25 | 1001100000 | Top | Unit No. 17 | Unit No. 18 | Unit No. 19 | Unit No. 20 | Unit No. 21 | Unit No. 22 | Unit No. 23 | Unit No. 24 | | | | | |
| | | Bottom | Unit No. 25 | Unit No. 26 | Unit No. 27 | Unit No. 28 | Unit No. 29 | Unit No. 30 | Unit No. 31 | Unit No. 32 | | | | | |
| 26 | 0101100000 | Top | Unit No. 33 | Unit No. 34 | Unit No. 35 | Unit No. 36 | Unit No. 37 | Unit No. 38 | Unit No. 39 | Unit No. 40 | | | | | |
| | | Bottom | Unit No. 41 | Unit No. 42 | Unit No. 43 | Unit No. 44 | Unit No. 45 | Unit No. 46 | Unit No. 47 | Unit No. 48 | | | | | |
| 27 | 1101100000 | Top | Unit No. 49 | Unit No. 50 | | | | | | | | | | | |
| | | Bottom | | | | | | | | | | | | | |
| 28 | 0011100000 | | | | | | | | | | | | | | |
| 29 | 1011100000 | | | | | | | | | | | | | | |
| 30 | 0111100000 | | | | | | | | | | | | | | |
| 31 | 1111100000 | | | | | | | | | | | | | | |
| 32 | 0000010000 | | | | | | | | | | | | | | |
| 33 | 1000010000 | | | | | | | | | | | | | | |
| 34 | 0100010000 | | | | | | | | | | | | | | |
| 35 | 1100010000 | | | | | | | | | | | | | | |
| 36 | 0010010000 | | | | | | | | | | | | | | |
| 37 | 1010010000 | | | | | | | | | | | | | | |
| 38 | 0110010000 | | | | | | | | | | | | | | |
| 39 | 1110010000 | Outdoor unit Operation mode | Permissible stop | Standby | Cooling | | Heating | | | | B | | | | |
| 40 | 0001010000 | | | | | | | | | | | | | | |
| 41 | 1001010000 | | | | | | | | | | | | | | |
| 42 | 0101010000 | Outdoor unit control mode | Stop | Thermo OFF | Abnormal stop | Scheduled control | Initial start up | Defrost | Oil balance | Low frequency oil recovery | A | A | | | |
| 43 | 1101010000 | | | Refrigerant recovery | | | | | | | A | A | | | |
| 44 | 0011010000 | | | | | | | | | | | | | | |

*1 A: The condition of either OC or OS is displayed individually. B: The condition of the entire refrigerant system is displayed.

Current data

| No. | SW1 | Item | Display | | | | | | | | Unit *1 | | | Remarks |
|-----|------------|---------------------------|---------|-----|-----|-----|----------------|-----|-----|-----|---------|----|---|------------------------------------|
| | | | LD1 | LD2 | LD3 | LD4 | LD5 | LD6 | LD7 | LD8 | OC | OS | | |
| 45 | 1011010000 | TH4 | | | | | -99.9 to 999.9 | | | | | A | A | The unit is [°C] |
| 46 | 0111010000 | TH3 | | | | | -99.9 to 999.9 | | | | | A | A | |
| 47 | 1111010000 | TH7 | | | | | -99.9 to 999.9 | | | | | A | A | |
| 48 | 0000110000 | TH6 | | | | | -99.9 to 999.9 | | | | | A | A | |
| 49 | 1000110000 | TH2 | | | | | -99.9 to 999.9 | | | | | A | A | |
| 50 | 0100110000 | TH5 | | | | | -99.9 to 999.9 | | | | | A | A | |
| 51 | 1100110000 | | | | | | | | | | | | | |
| 52 | 0010110000 | | | | | | | | | | | | | |
| 53 | 1010110000 | | | | | | | | | | | | | |
| 54 | 0110110000 | | | | | | | | | | | | | |
| 55 | 1110110000 | | | | | | | | | | | | | |
| 56 | 0001110000 | THHS1 | | | | | -99.9 to 999.9 | | | | | A | A | The unit is [°C] |
| 57 | 1001110000 | THBOX | | | | | -99.9 to 999.9 | | | | | A | A | |
| 58 | 0101110000 | High-pressure sensor data | | | | | -99.9 to 999.9 | | | | | A | A | The unit is [kgf/cm ²] |
| 59 | 1101110000 | Low-pressure sensor data | | | | | -99.9 to 999.9 | | | | | A | A | |
| 60 | 0011110000 | | | | | | | | | | | | | |
| 61 | 1011110000 | | | | | | | | | | | | | |
| 62 | 0111110000 | | | | | | | | | | | | | |
| 63 | 1111110000 | | | | | | | | | | | | | |
| 64 | 0000010000 | | | | | | | | | | | | | |
| 65 | 1000010000 | | | | | | | | | | | | | |
| 66 | 0100010000 | | | | | | | | | | | | | |
| 67 | 1100010000 | | | | | | | | | | | | | |
| 68 | 0010010000 | | | | | | | | | | | | | |
| 69 | 1010010000 | | | | | | | | | | | | | |
| 70 | 0110010000 | | | | | | | | | | | | | |
| 71 | 1110010000 | | | | | | | | | | | | | |

*1 A: The condition of either OC or OS is displayed individually. B: The condition of the entire refrigerant system is displayed.

Current data

| No. | SW1 | Item | Display | | | | | | | | Unit ^{*1} | | Remarks | |
|-----|------------|------------------------------|---------|-----|-----|-----|----------------|-----|-----|-----|--------------------|----|---------|---|
| | | | LD1 | LD2 | LD3 | LD4 | LD5 | LD6 | LD7 | LD8 | OC | OS | | |
| 72 | 0001001000 | | | | | | | | | | | | | |
| 73 | 1001001000 | | | | | | | | | | | | | |
| 74 | 0101001000 | | | | | | | | | | | | | |
| 75 | 1101001000 | | | | | | | | | | | | | |
| 76 | 0011001000 | | | | | | | | | | | | | |
| 77 | 1011001000 | | | | | | | | | | | | | |
| 78 | 0111001000 | Σ Qj | | | | | 0000 to 9999 | | | | | B | B | |
| 79 | 1111001000 | Σ Qjc | | | | | 0000 to 9999 | | | | | B | B | |
| 80 | 0000101000 | Σ Qjh | | | | | 0000 to 9999 | | | | | B | B | |
| 81 | 1000101000 | Target Tc | | | | | -99.9 to 999.9 | | | | | B | | The unit is [°C] |
| 82 | 0100101000 | Target Te | | | | | -99.9 to 999.9 | | | | | B | | |
| 83 | 1100101000 | Tc | | | | | -99.9 to 999.9 | | | | | A | A | |
| 84 | 0010101000 | Te | | | | | -99.9 to 999.9 | | | | | A | A | |
| 85 | 1010101000 | | | | | | | | | | | | | |
| 86 | 0110101000 | Total frequencies (OC+OS) | | | | | 0000 to 9999 | | | | | B | | Control data [Hz] |
| 87 | 1110101000 | Total frequency of each unit | | | | | 0000 to 9999 | | | | | A | A | |
| 88 | 0001101000 | COMP frequency | | | | | 0000 to 9999 | | | | | A | A | |
| 89 | 1001101000 | | | | | | | | | | | | | |
| 90 | 0101101000 | | | | | | | | | | | | | |
| 91 | 1101101000 | COMP operating frequency | | | | | 0000 to 9999 | | | | | A | A | The unit is [rps] Output frequency of the inverter depends on the type of compressor and equals the integer multiples (x1, x2 etc.) of the operating frequency of the compressor |
| 92 | 0011101000 | | | | | | | | | | | | | |
| 93 | 1011101000 | All AK (OC+OS) | | | | | 0000 to 9999 | | | | | B | | |

*1 A: The condition of either OC or OS is displayed individually. B: The condition of the entire refrigerant system is displayed.

Current data

| No. | SW1 1234567890 | Item | Display | | | | | | | | Unit ^{*1} (A, B) ^{*1} | | Remarks |
|-----|-------------------|---|---------------|-----|-----|-----|-----|-----|-----|-----|--|----|---|
| | | | LD1 | LD2 | LD3 | LD4 | LD5 | LD6 | LD7 | LD8 | OC | OS | |
| 94 | 0111101000 | AK | 0000 to 9999 | | | | | | | | A | A | |
| 95 | 1111101000 | FAN | 0000 to 9999 | | | | | | | | A | A | Fan output [%] |
| 96 | 0000011000 | Fan inverter output frequency | 0000 to 9999 | | | | | | | | A | A | Twice the actual output frequency |
| 97 | 1000011000 | | | | | | | | | | | | |
| 98 | 0100011000 | | | | | | | | | | | | |
| 99 | 1100011000 | | | | | | | | | | | | |
| 100 | 0010011000 | | | | | | | | | | | | |
| 101 | 1010011000 | | | | | | | | | | | | |
| 102 | 0110011000 | | | | | | | | | | | | |
| 103 | 1110011000 | LEV1 | 0 to 480 | | | | | | | | A | A | Outdoor LEV opening (Fully open: 480) |
| 104 | 0001011000 | LEV2 | 60 to 1400 | | | | | | | | A | A | Outdoor LEV opening (Fully open: 1400) |
| 105 | 1001011000 | | | | | | | | | | | | |
| 106 | 0101011000 | | | | | | | | | | | | |
| 107 | 1101011000 | | | | | | | | | | | | |
| 108 | 0011011000 | | | | | | | | | | | | |
| 109 | 1011011000 | | | | | | | | | | | | |
| 110 | 0111011000 | | | | | | | | | | | | |
| 111 | 1111011000 | COMP bus voltage | 00.0 to 999.9 | | | | | | | | A | A | The unit is [V] |
| 112 | 0000111000 | | | | | | | | | | | | |
| 113 | 1000111000 | | | | | | | | | | | | |
| 114 | 0100111000 | | | | | | | | | | | | |
| 115 | 1100111000 | | | | | | | | | | | | |
| 116 | 0010111000 | Number of times the unit went into the mode to remedy wet vapor suction | 0000 to 9999 | | | | | | | | B | | |

*1 A: The condition of either OC or OS is displayed individually. B: The condition of the entire refrigerant system is displayed.

Current data

| No. | SW1 | Item | Display | | | | | | | | Unit (A, B)*1 | | Remarks | |
|-----|------------|--|---------------------------|-------------------------|------------------------|---------------------|-----|-----|-----|-----|------------------|----|--|---|
| | | | LD1 | LD2 | LD3 | LD4 | LD5 | LD6 | LD7 | LD8 | OC | OS | | |
| 117 | 1234567890 | COMP Operation time Upper 4 digits | 0000 to 9999 | | | | | | | | A | A | The unit is [h] | |
| 118 | 0110111000 | COMP Operation time Lower 4 digits | 0000 to 9999 | | | | | | | | A | A | | |
| 119 | 1110111000 | Integrated cleaning time (minute) | 0000 to 9999 | | | | | | | | B | | | |
| 120 | 0001111000 | | | | | | | | | | | | | |
| 121 | 1001111000 | Backup mode | Abnormal pressure rise | High-pres- sure drop | Low-pres- sure drop | Abnormal Td rise | | | | | | A | A | Stays lit for 90 seconds after the completion of backup control |
| 122 | 0101111000 | | | | | | | | | | | | | |
| 123 | 1101111000 | COMP number of start- stop events Upper 4 digits | 0000 to 9999 | | | | | | | | A | A | Count-up at start-up The unit is [Time] | |
| 124 | 0011111000 | COMP number of start- stop events Lower 4 digits | 0000 to 9999 | | | | | | | | A | A | | |
| 125 | 1011111000 | | | | | | | | | | | | | |
| 126 | 0111111000 | | | | | | | | | | | | | |
| 127 | 1111111000 | | | | | | | | | | | | | |
| 128 | 0000000100 | | | | | | | | | | | | | |
| 129 | 1000000100 | Integrated operation time of compressor (for rotation purpose) | 0000 to 9999 | | | | | | | | B | | The unit is [h] | |
| 130 | 0100000100 | | | | | | | | | | | | | |
| 131 | 1100000100 | | | | | | | | | | | | | |
| 132 | 0010000100 | | | | | | | | | | | | | |
| 133 | 1010000100 | | | | | | | | | | | | | |
| 134 | 0110000100 | | | | | | | | | | | | | |
| 135 | 1110000100 | | | | | | | | | | | | | |
| 136 | 0001000100 | | | | | | | | | | | | | |
| 137 | 1001000100 | | | | | | | | | | | | | |

*1 A: The condition of either OC or OS is displayed individually. B: The condition of the entire refrigerant system is displayed.

Current data

| No. | SW1 1234567890 | Item | Display | | | | | | | | Unit *1 | | Remarks | |
|-----|-------------------|------|---------|-----|-----|-----|-----|-----|-----|-----|---------|----|---------|--|
| | | | LD1 | LD2 | LD3 | LD4 | LD5 | LD6 | LD7 | LD8 | OC | OS | | |
| 138 | 0101000100 | | | | | | | | | | | | | |
| 139 | 1101000100 | | | | | | | | | | | | | |
| 140 | 0011000100 | | | | | | | | | | | | | |
| 141 | 1011000100 | | | | | | | | | | | | | |
| 142 | 0111000100 | | | | | | | | | | | | | |
| 143 | 1111000100 | | | | | | | | | | | | | |
| 144 | 0000100100 | | | | | | | | | | | | | |
| 145 | 1000100100 | | | | | | | | | | | | | |
| 146 | 0100100100 | | | | | | | | | | | | | |
| 147 | 1100100100 | | | | | | | | | | | | | |
| 148 | 0010100100 | | | | | | | | | | | | | |
| 149 | 1010100100 | | | | | | | | | | | | | |
| 150 | 0110100100 | | | | | | | | | | | | | |
| 151 | 1110100100 | | | | | | | | | | | | | |
| 152 | 0001100100 | | | | | | | | | | | | | |
| 153 | 1001100100 | | | | | | | | | | | | | |
| 154 | 0101100100 | | | | | | | | | | | | | |
| 155 | 1101100100 | | | | | | | | | | | | | |
| 156 | 0011100100 | | | | | | | | | | | | | |
| 157 | 1011100100 | | | | | | | | | | | | | |
| 158 | 0111100100 | | | | | | | | | | | | | |
| 159 | 1111100100 | | | | | | | | | | | | | |
| 160 | 0000010100 | | | | | | | | | | | | | |
| 161 | 1000010100 | | | | | | | | | | | | | |
| 162 | 0100010100 | | | | | | | | | | | | | |
| 163 | 1100010100 | | | | | | | | | | | | | |
| 164 | 0010010100 | | | | | | | | | | | | | |
| 165 | 1010010100 | | | | | | | | | | | | | |

*1 A: The condition of either OC or OS is displayed individually. B: The condition of the entire refrigerant system is displayed.

Current data

| No. | SW1 1234567890 | Item | Display | | | | | | | | Unit ^{*1} (A, B) ^{*1} | | Remarks | |
|-----|-------------------|------|---------|-----|-----|-----|-----|-----|-----|-----|--|----|---------|--|
| | | | LD1 | LD2 | LD3 | LD4 | LD5 | LD6 | LD7 | LD8 | OC | OS | | |
| 166 | 0110010100 | | | | | | | | | | | | | |
| 167 | 1110010100 | | | | | | | | | | | | | |
| 168 | 0001010100 | | | | | | | | | | | | | |
| 169 | 1001010100 | | | | | | | | | | | | | |
| 170 | 0101010100 | | | | | | | | | | | | | |
| 171 | 1101010100 | | | | | | | | | | | | | |
| 172 | 0011010100 | | | | | | | | | | | | | |
| 173 | 1011010100 | | | | | | | | | | | | | |
| 174 | 0111010100 | | | | | | | | | | | | | |
| 175 | 1111010100 | | | | | | | | | | | | | |
| 176 | 0000110100 | | | | | | | | | | | | | |
| 177 | 1000110100 | | | | | | | | | | | | | |

*1 A: The condition of either OC or OS is displayed individually. B: The condition of the entire refrigerant system is displayed.

Current data

| No. | SW1 | Item | Display | | | | | | | | | | Unit ^{*1} (A, B) ^{*1} | | | Remarks |
|-----|------------|---|---------------------------------------|-----|-----|-----|-----|-----|-----|-----|----|----|--|---|--|---------|
| | | | LD1 | LD2 | LD3 | LD4 | LD5 | LD6 | LD7 | LD8 | OC | OS | OS | | | |
| 178 | 0100110100 | Error history 1 | 0000 to 9999 | | | | | | | | | | B | B | Address and error codes highlighted If no errors are detected, "----" appears on the display. Preliminary error information of the OS does not appear on the OC. Neither preliminary error information of the OC nor error information of the IC appears on the OS. | |
| 179 | 1100110100 | Error details of inverter | Error details of inverter (0001-0120) | | | | | | | | | | A | A | | |
| 180 | 0010110100 | Error history 2 | 0000 to 9999 | | | | | | | | | | B | B | | |
| 181 | 1010110100 | Error details of inverter | Error details of inverter (0001-0120) | | | | | | | | | | A | A | | |
| 182 | 0110110100 | Error history 3 | 0000 to 9999 | | | | | | | | | | B | B | | |
| 183 | 1110110100 | Error details of inverter | Error details of inverter (0001-0120) | | | | | | | | | | A | A | | |
| 184 | 0001110100 | Error history 4 | 0000 to 9999 | | | | | | | | | | B | B | | |
| 185 | 1001110100 | Error details of inverter | Error details of inverter (0001-0120) | | | | | | | | | | A | A | | |
| 186 | 0101110100 | Error history 5 | 0000 to 9999 | | | | | | | | | | B | B | | |
| 187 | 1101110100 | Error details of inverter | Error details of inverter (0001-0120) | | | | | | | | | | A | A | | |
| 188 | 0011110100 | Error history 6 | 0000 to 9999 | | | | | | | | | | B | B | | |
| 189 | 1011110100 | Error details of inverter | Error details of inverter (0001-0120) | | | | | | | | | | A | A | | |
| 190 | 0111110100 | Error history 7 | 0000 to 9999 | | | | | | | | | | B | B | | |
| 191 | 1111110100 | Error details of inverter | Error details of inverter (0001-0120) | | | | | | | | | | A | A | | |
| 192 | 0000001100 | Error history 8 | 0000 to 9999 | | | | | | | | | | B | B | | |
| 193 | 1000001100 | Error details of inverter | Error details of inverter (0001-0120) | | | | | | | | | | A | A | | |
| 194 | 0100001100 | Error history 9 | 0000 to 9999 | | | | | | | | | | B | B | | |
| 195 | 1100001100 | Error details of inverter | Error details of inverter (0001-0120) | | | | | | | | | | A | A | | |
| 196 | 0010001100 | Error history 10 | 0000 to 9999 | | | | | | | | | | B | B | | |
| 197 | 1010001100 | Error details of inverter | Error details of inverter (0001-0120) | | | | | | | | | | A | A | | |
| 198 | 0110001100 | Error history of inverter (At the time of last data backup before error) | 0000 to 9999 | | | | | | | | | | B | B | | |
| 199 | 1110001100 | Error details of inverter | Error details of inverter (0001-0120) | | | | | | | | | | A | A | | |
| 200 | 0001001100 | | | | | | | | | | | | | | | |

*1 A: The condition of either OC or OS is displayed individually. B: The condition of the entire refrigerant system is displayed.

Data before error

| No. | SW1 | Item | Display | | | | | | | | Unit ^{*1} | | Remarks |
|-----|------------|---------------------------------|-------------------|----------------------|------------------------|-------------------------|-------------------|---------|---|---|--------------------|----|---------|
| | | | LD1 | LD2 | LD3 | LD4 | LD5 | LD6 | LD7 | LD8 | OC | OS | |
| 201 | 1001001100 | Outdoor unit operation status | | | 3-minutes restart mode | Compressor in operation | Preliminary error | Error | 3-minutes restart after instantaneous power failure | Preliminary low pressure error | A | A | |
| 202 | 0101001100 | OC/OS identification | OC/OS-1/OS-2 | | | | | | | | A | A | |
| 203 | 1101001100 | | | | | | | | | | | | |
| 204 | 0011001100 | | | | | | | | | | | | |
| 205 | 1011001100 | Outdoor unit Operation mode | Permissible stop | Standby | Cooling | | Heating | | | | B | | |
| 206 | 0111001100 | | | | | | | | | | | | |
| 207 | 1111001100 | | | | | | | | | | | | |
| 208 | 0000101100 | Outdoor unit control mode | Stop | Thermo OFF | Abnormal stop | Scheduled control | Initial start up | Defrost | Oil balance | Low frequency oil recovery | A | A | |
| 209 | 1000101100 | | | Refrigerant recovery | | | | | | | A | A | |
| 210 | 0100101100 | | | | | | | | | | | | |
| 211 | 1100101100 | Relay output display 1 Lighting | Comp in operation | | | | 72C | | OC | Always lit | A | A | |
| 212 | 0010101100 | Relay output display 2 Lighting | 21S4a | | CH11 | | SV1a | | | | A | A | |
| | | Relay output display 3 Lighting | | | 21S4b | SV5b | | | | | | | |
| 213 | 1010101100 | | | | | | | | | Lit while power to the indoor units is being supplied | A | A | |
| 214 | 0110101100 | | | | | | | | SV9 | | | | |
| 215 | 1110101100 | | | | | | | | | | | | |

*1 A: The condition of either OC or OS is displayed individually. B: The condition of the entire refrigerant system is displayed.

| Data before error | | SW1 | Item | Display | | | | | | | | Unit *1 | | Remarks | |
|-------------------|--|------------|---------------------------|---------|-----|-----|-----|-----|----------------|-----|-----|---------|----|---------|------------------------------------|
| | | | | LD1 | LD2 | LD3 | LD4 | LD5 | LD6 | LD7 | LD8 | OC | OS | | |
| 216 | | 0001101100 | TH4 | | | | | | -99.9 to 999.9 | | | | A | A | The unit is [°C] |
| 217 | | 1001101100 | TH3 | | | | | | -99.9 to 999.9 | | | | A | A | |
| 218 | | 0101101100 | TH7 | | | | | | -99.9 to 999.9 | | | | A | A | |
| 219 | | 1101101100 | TH6 | | | | | | -99.9 to 999.9 | | | | A | A | |
| 220 | | 0011101100 | TH2 | | | | | | -99.9 to 999.9 | | | | A | A | |
| 221 | | 1011101100 | TH5 | | | | | | -99.9 to 999.9 | | | | A | A | |
| 222 | | 0111101100 | | | | | | | | | | | | | |
| 223 | | 1111101100 | | | | | | | | | | | | | |
| 224 | | 0000011100 | | | | | | | | | | | | | |
| 225 | | 1000011100 | | | | | | | | | | | | | |
| 226 | | 0100011100 | | | | | | | | | | | | | |
| 227 | | 1100011100 | THHS1 | | | | | | -99.9 to 999.9 | | | | A | A | The unit is [°C] |
| 228 | | 0010011100 | THBOX | | | | | | -99.9 to 999.9 | | | | A | A | |
| 229 | | 1010011100 | High-pressure sensor data | | | | | | -99.9 to 999.9 | | | | A | A | The unit is [kgf/cm ²] |
| 230 | | 0110011100 | Low-pressure sensor data | | | | | | -99.9 to 999.9 | | | | A | A | |
| 231 | | 1110011100 | | | | | | | | | | | | | |
| 232 | | 0001011100 | | | | | | | | | | | | | |
| 233 | | 1001011100 | | | | | | | | | | | | | |
| 234 | | 0101011100 | | | | | | | | | | | | | |
| 235 | | 1101011100 | | | | | | | | | | | | | |
| 236 | | 0011011100 | | | | | | | | | | | | | |
| 237 | | 1011011100 | | | | | | | | | | | | | |
| 238 | | 0111011100 | | | | | | | | | | | | | |
| 239 | | 1111011100 | | | | | | | | | | | | | |
| 240 | | 0000111100 | | | | | | | | | | | | | |
| 241 | | 1000111100 | | | | | | | | | | | | | |
| 242 | | 0100111100 | | | | | | | | | | | | | |

*1 A: The condition of either OC or OS is displayed individually. B: The condition of the entire refrigerant system is displayed.

| Data before error | | SW1 | Item | Display | | | | | | | | Unit**1 | | Remarks | | |
|-------------------|--|------------|-------------------------------|---------|-----|-----|-----|-----|----------------|-----|-----|---------|----|---------|---|-----------------------------------|
| | | | | LD1 | LD2 | LD3 | LD4 | LD5 | LD6 | LD7 | LD8 | OC | OS | | | |
| 243 | | 1234567890 | | | | | | | | | | | | | | |
| 244 | | 1100111100 | | | | | | | | | | | | | | |
| 245 | | 0010111100 | | | | | | | | | | | | | | |
| 246 | | 1010111100 | | | | | | | | | | | | | | |
| 247 | | 0110111100 | | | | | | | | | | | | | | |
| 248 | | 1110111100 | | | | | | | | | | | | | | |
| 249 | | 0001111100 | | | | | | | | | | | | | | |
| 250 | | 1001111100 | Σ Qj | | | | | | 0000 to 9999 | | | | | B | B | |
| 251 | | 0101111100 | Σ Qjc | | | | | | 0000 to 9999 | | | | | B | B | |
| 252 | | 1101111100 | Σ Qjh | | | | | | 0000 to 9999 | | | | | B | B | |
| 253 | | 0011111100 | Target Tc | | | | | | -99.9 to 999.9 | | | | | B | | The unit is [°C] |
| 254 | | 1011111100 | Target Te | | | | | | -99.9 to 999.9 | | | | | B | | |
| 255 | | 0111111100 | Tc | | | | | | -99.9 to 999.9 | | | | | A | A | The unit is [°C] |
| 256 | | 1111111100 | Te | | | | | | -99.9 to 999.9 | | | | | A | A | |
| 257 | | 0000000010 | | | | | | | | | | | | | | |
| 258 | | 1000000010 | Total frequencies (OC+OS) | | | | | | 0000 to 9999 | | | | | B | | Control data [Hz] |
| 259 | | 0100000010 | Total frequency of each unit | | | | | | 0000 to 9999 | | | | | A | A | |
| 260 | | 1100000010 | COMP frequency | | | | | | 0000 to 9999 | | | | | A | A | |
| 261 | | 0010000010 | | | | | | | | | | | | | | |
| 262 | | 1010000010 | COMP operating frequency | | | | | | 0000 to 9999 | | | | | A | A | The unit is [rps] |
| 263 | | 0110000010 | | | | | | | | | | | | | | |
| 264 | | 1110000010 | All AK (OC+OS) | | | | | | 0000 to 9999 | | | | | B | | |
| 265 | | 0001000010 | AK | | | | | | 0000 to 9999 | | | | | A | A | |
| 266 | | 1001000010 | FAN | | | | | | 0000 to 9999 | | | | | A | A | Fan inverter output [%] |
| 267 | | 1101000010 | Fan inverter output frequency | | | | | | 0000 to 9999 | | | | | A | A | Twice the actual output frequency |

*1 A: The condition of either OC or OS is displayed individually. B: The condition of the entire refrigerant system is displayed.

Data before error

| No. | SW1 | Item | Display | | | | | | | | Unit**1 | | Remarks | |
|-----|------------|---------------------------------------|---------|-----|-----|-----|---------------|-----|-----|-----|---------|----|---------|--|
| | | | LD1 | LD2 | LD3 | LD4 | LD5 | LD6 | LD7 | LD8 | OC | OS | | |
| 268 | 0011000010 | | | | | | | | | | | | | |
| 269 | 1011000010 | | | | | | | | | | | | | |
| 270 | 0111000010 | | | | | | | | | | | | | |
| 271 | 1111000010 | | | | | | | | | | | | | |
| 272 | 0000100010 | | | | | | | | | | | | | |
| 273 | 1000100010 | | | | | | | | | | | | | |
| 274 | 0100100010 | LEV1 | | | | | 0 to 480 | | | | | A | A | Outdoor unit LEV opening (Fully open: 480) |
| 275 | 1100100010 | LEV2 | | | | | 60 to 1400 | | | | | A | A | Outdoor unit LEV opening (Fully open: 1400) |
| 276 | 0010100010 | | | | | | | | | | | | | |
| 277 | 1010100010 | | | | | | | | | | | | | |
| 278 | 0110100010 | | | | | | | | | | | | | |
| 279 | 1110100010 | | | | | | | | | | | | | |
| 280 | 0001100010 | | | | | | | | | | | | | |
| 281 | 1001100010 | | | | | | | | | | | | | |
| 282 | 0101100010 | COMP bus voltage | | | | | 00.0 to 999.9 | | | | | A | A | The unit is [V] |
| 283 | 1101100010 | | | | | | | | | | | | | |
| 284 | 0011100010 | | | | | | | | | | | | | |
| 285 | 1011100010 | | | | | | | | | | | | | |
| 286 | 0111100010 | | | | | | | | | | | | | |
| 287 | 1111100010 | | | | | | | | | | | | | |
| 288 | 0000010010 | COMP Operation time Upper 4 digits | | | | | 0000 to 9999 | | | | | A | A | The unit is [h] |
| 289 | 1000010010 | COMP Operation time Lower 4 digits | | | | | 0000 to 9999 | | | | | A | A | |
| 290 | 0100010010 | | | | | | | | | | | | | |
| 291 | 1100010010 | | | | | | | | | | | | | |
| 292 | 0010010010 | | | | | | | | | | | | | |

*1 A: The condition of either OC or OS is displayed individually. B: The condition of the entire refrigerant system is displayed.

Data before error

| No. | SW1 | Item | Display | | | | | | | | Unit *1 | | Remarks | | |
|-----|------------|--|--------------|-----|-----|-----|-----|-----|-----|-----|---------|----|--|--|--|
| | | | LD1 | LD2 | LD3 | LD4 | LD5 | LD6 | LD7 | LD8 | OC | OS | | | |
| 293 | 1010010010 | | | | | | | | | | | | | | |
| 294 | 0110010010 | COMP number of start-stop events Upper 4 digits | 0000 to 9999 | | | | | | | | A | A | Count-up at start-up The unit is [Time] | | |
| 295 | 1110010010 | COMP number of start-stop events Lower 4 digits | 0000 to 9999 | | | | | | | | A | A | | | |
| 296 | 0001010010 | | | | | | | | | | | | | | |
| 297 | 1001010010 | | | | | | | | | | | | | | |
| 298 | 0101010010 | | | | | | | | | | | | | | |
| 299 | 1101010010 | | | | | | | | | | | | | | |
| 300 | 0011010010 | Integrated operation time of compressor (for rotation purpose) | 0000 to 9999 | | | | | | | | B | | The unit is [h] | | |

*1 A: The condition of either OC or OS is displayed individually. B: The condition of the entire refrigerant system is displayed.

Current data

| No. | SW1 | Item | Display | | | | | | | | Unit (A, B) ^{*1} | | Remarks | |
|-----|------------|-------------------|---------|-----|-----|-----|-----|-----|-----|-----|------------------------------|----|---------|--|
| | | | LD1 | LD2 | LD3 | LD4 | LD5 | LD6 | LD7 | LD8 | OC | OS | | |
| 301 | 1011010010 | Power supply unit | | | | | | | | | | | B | |
| 302 | 0111010010 | Start-up unit | | | | | | | | | | | B | |
| 303 | 1111010010 | | | | | | | | | | | | | |
| 304 | 0000110010 | | | | | | | | | | | | | |
| 305 | 1000110010 | | | | | | | | | | | | | |
| 306 | 0100110010 | | | | | | | | | | | | | |
| 307 | 1100110010 | | | | | | | | | | | | | |
| 308 | 0010110010 | | | | | | | | | | | | | |
| 309 | 1010110010 | | | | | | | | | | | | | |
| 310 | 0110110010 | | | | | | | | | | | | | |
| 311 | 1110110010 | | | | | | | | | | | | | |
| 312 | 0001110010 | | | | | | | | | | | | | |
| 313 | 1001110010 | | | | | | | | | | | | | |
| 314 | 0101110010 | | | | | | | | | | | | | |
| 315 | 1101110010 | | | | | | | | | | | | | |
| 316 | 0011110010 | | | | | | | | | | | | | |
| 317 | 1011110010 | | | | | | | | | | | | | |
| 318 | 0111110010 | | | | | | | | | | | | | |
| 319 | 1111110010 | | | | | | | | | | | | | |
| 320 | 0000001010 | | | | | | | | | | | | | |
| 321 | 1000001010 | | | | | | | | | | | | | |
| 322 | 0100001010 | | | | | | | | | | | | | |
| 323 | 1100001010 | | | | | | | | | | | | | |
| 324 | 0010001010 | | | | | | | | | | | | | |
| 325 | 1010001010 | | | | | | | | | | | | | |
| 326 | 0110001010 | | | | | | | | | | | | | |
| 327 | 1110001010 | | | | | | | | | | | | | |

*1 A: The condition of either OC or OS is displayed individually. B: The condition of the entire refrigerant system is displayed.

Current data

| No. | SW1 1234567890 | Item | Display | | | | | | | | Unit (A, B) ^{*1} | | Remarks | |
|-----|-------------------|------|---------|-----|-----|-----|-----|-----|-----|-----|------------------------------|----|---------|--|
| | | | LD1 | LD2 | LD3 | LD4 | LD5 | LD6 | LD7 | LD8 | OC | OS | | |
| 328 | 0001001010 | | | | | | | | | | | | | |
| 329 | 1001001010 | | | | | | | | | | | | | |
| 330 | 0101001010 | | | | | | | | | | | | | |
| 331 | 1101001010 | | | | | | | | | | | | | |
| 332 | 0011001010 | | | | | | | | | | | | | |
| 333 | 1011001010 | | | | | | | | | | | | | |
| 334 | 0111001010 | | | | | | | | | | | | | |
| 335 | 1111001010 | | | | | | | | | | | | | |
| 336 | 0000101010 | | | | | | | | | | | | | |
| 337 | 1000101010 | | | | | | | | | | | | | |
| 338 | 0100101010 | | | | | | | | | | | | | |
| 339 | 1100101010 | | | | | | | | | | | | | |
| 340 | 0010101010 | | | | | | | | | | | | | |
| 341 | 1010101010 | | | | | | | | | | | | | |
| 342 | 0110101010 | | | | | | | | | | | | | |
| 343 | 1110101010 | | | | | | | | | | | | | |
| 344 | 0001101010 | | | | | | | | | | | | | |
| 345 | 1001101010 | | | | | | | | | | | | | |
| 346 | 0101101010 | | | | | | | | | | | | | |
| 347 | 1101101010 | | | | | | | | | | | | | |
| 348 | 0011101010 | | | | | | | | | | | | | |
| 349 | 1011101010 | | | | | | | | | | | | | |
| 350 | 0111101010 | | | | | | | | | | | | | |

*1 A: The condition of either OC or OS is displayed individually. B: The condition of the entire refrigerant system is displayed.

Data on indoor unit system

| No. | SW1 | Item | Display | | | | | | | | Unit (A, B) *1 | | Remarks | | |
|-----|------------|----------------------------|--------------|-----|-----|-----|-----|-----|-----|-----|-------------------|----|---------|--|---------------------------------------|
| | | | LD1 | LD2 | LD3 | LD4 | LD5 | LD6 | LD7 | LD8 | OC | OS | | | |
| 351 | 1111101010 | IC1 Address/capacity code | 0000 to 9999 | | | | | | | | | | | | Displayed alternately every 5 seconds |
| 352 | 0000011010 | IC2 Address/capacity code | 0000 to 9999 | | | | | | | | | | | | |
| 353 | 1000011010 | IC3 Address/capacity code | 0000 to 9999 | | | | | | | | | | | | |
| 354 | 0100011010 | IC4 Address/capacity code | 0000 to 9999 | | | | | | | | | | | | |
| 355 | 1100011010 | IC5 Address/capacity code | 0000 to 9999 | | | | | | | | | | | | |
| 356 | 0010011010 | IC6 Address/capacity code | 0000 to 9999 | | | | | | | | | | | | |
| 357 | 1010011010 | IC7 Address/capacity code | 0000 to 9999 | | | | | | | | | | | | |
| 358 | 0110011010 | IC8 Address/capacity code | 0000 to 9999 | | | | | | | | | | | | |
| 359 | 1110011010 | IC9 Address/capacity code | 0000 to 9999 | | | | | | | | | | | | |
| 360 | 0001011010 | IC10 Address/capacity code | 0000 to 9999 | | | | | | | | | | | | |
| 361 | 1001011010 | IC11 Address/capacity code | 0000 to 9999 | | | | | | | | | | | | |
| 362 | 0101011010 | IC12 Address/capacity code | 0000 to 9999 | | | | | | | | | | | | |
| 363 | 1101011010 | IC13 Address/capacity code | 0000 to 9999 | | | | | | | | | | | | |
| 364 | 0011011010 | IC14 Address/capacity code | 0000 to 9999 | | | | | | | | | | | | |
| 365 | 1011011010 | IC15 Address/capacity code | 0000 to 9999 | | | | | | | | | | | | |
| 366 | 0111011010 | IC16 Address/capacity code | 0000 to 9999 | | | | | | | | | | | | |
| 367 | 1111011010 | IC17 Address/capacity code | 0000 to 9999 | | | | | | | | | | | | |

*1 A: The condition of either OC or OS is displayed individually. B: The condition of the entire refrigerant system is displayed.

Data on indoor unit system

| No. | SW1 | Item | Display | | | | | | | | Unit (A, B) *1 | | Remarks | | |
|-----|------------|----------------------------|--------------|-----|-----|-----|-----|-----|-----|--------------|-------------------|----|---------|--|---------------------------------------|
| | | | LD1 | LD2 | LD3 | LD4 | LD5 | LD6 | LD7 | LD8 | OC | OS | | | |
| 396 | 0011000110 | IC46 Address/capacity code | 0000 to 9999 | | | | | | | 0000 to 9999 | | | B | | Displayed alternately every 5 seconds |
| 397 | 1011000110 | IC47 Address/capacity code | 0000 to 9999 | | | | | | | 0000 to 9999 | | | | | |
| 398 | 0111000110 | IC48 Address/capacity code | 0000 to 9999 | | | | | | | 0000 to 9999 | | | | | |
| 399 | 1111000110 | IC49 Address/capacity code | 0000 to 9999 | | | | | | | 0000 to 9999 | | | | | |
| 400 | 0000100110 | IC50 Address/capacity code | 0000 to 9999 | | | | | | | 0000 to 9999 | | | | | |
| 401 | 1000100110 | | | | | | | | | | | | | | |
| 402 | 0100100110 | | | | | | | | | | | | | | |
| 403 | 1100100110 | | | | | | | | | | | | | | |
| 404 | 0010100110 | | | | | | | | | | | | | | |
| 405 | 1010100110 | | | | | | | | | | | | | | |
| 406 | 0110100110 | | | | | | | | | | | | | | |
| 407 | 1110100110 | | | | | | | | | | | | | | |
| 408 | 0001100110 | IC1 Suction temperature | | | | | | | | | | | B | | The unit is [°C] |
| 409 | 1001100110 | IC2 Suction temperature | | | | | | | | | | | | | |
| 410 | 0101100110 | IC3 Suction temperature | | | | | | | | | | | | | |
| 411 | 1101100110 | IC4 Suction temperature | | | | | | | | | | | | | |

*1 A: The condition of either OC or OS is displayed individually. B: The condition of the entire refrigerant system is displayed.

Data on indoor unit system

| No. | SW1 | Item | Display | | | | | | | | Unit (A, B) *1 | | Remarks | |
|-----|------------|--------------------------|---------|-----|-----|-----|-----|-----|-----|-----|-------------------|----|---------|------------------|
| | | | LD1 | LD2 | LD3 | LD4 | LD5 | LD6 | LD7 | LD8 | OC | OS | | |
| 412 | 0011100110 | IC5 Suction temperature | | | | | | | | | | | | The unit is [°C] |
| 413 | 1011100110 | IC6 Suction temperature | | | | | | | | | | | | |
| 414 | 0111100110 | IC7 Suction temperature | | | | | | | | | | | | |
| 415 | 1111100110 | IC8 Suction temperature | | | | | | | | | | | | |
| 416 | 0000010110 | IC9 Suction temperature | | | | | | | | | | | | |
| 417 | 1000010110 | IC10 Suction temperature | | | | | | | | | | | | |
| 418 | 0100010110 | IC11 Suction temperature | | | | | | | | | | | | |
| 419 | 1100010110 | IC12 Suction temperature | | | | | | | | | | | | |
| 420 | 0010010110 | IC13 Suction temperature | | | | | | | | | | | | |
| 421 | 1010010110 | IC14 Suction temperature | | | | | | | | | | | | |
| 422 | 0110010110 | IC15 Suction temperature | | | | | | | | | | | | |
| 423 | 1110010110 | IC16 Suction temperature | | | | | | | | | | | | |
| 424 | 0001010110 | IC17 Suction temperature | | | | | | | | | | | | |
| 425 | 1001010110 | IC18 Suction temperature | | | | | | | | | | | | |
| 426 | 0101010110 | IC19 Suction temperature | | | | | | | | | | | | |
| 427 | 1101010110 | IC20 Suction temperature | | | | | | | | | | | | |
| 428 | 0011010110 | IC21 Suction temperature | | | | | | | | | | | | |
| 429 | 1011010110 | IC22 Suction temperature | | | | | | | | | | | | |
| 430 | 0111010110 | IC23 Suction temperature | | | | | | | | | | | | |
| 431 | 1111010110 | IC24 Suction temperature | | | | | | | | | | | | |
| 432 | 0000110110 | IC25 Suction temperature | | | | | | | | | | | | |
| 433 | 1000110110 | IC26 Suction temperature | | | | | | | | | | | | |
| 434 | 0100110110 | IC27 Suction temperature | | | | | | | | | | | | |
| 435 | 1100110110 | IC28 Suction temperature | | | | | | | | | | | | |

*1 A: The condition of either OC or OS is displayed individually. B: The condition of the entire refrigerant system is displayed.

Data on indoor unit system

| No. | SW1 | Item | Display | | | | | | | | Unit (A, B) *1 | | Remarks | |
|-----|------------|-----------------------------|---------|-----|-----|-----|-----|-----|-----|-----|----------------|----|---------|------------------|
| | | | LD1 | LD2 | LD3 | LD4 | LD5 | LD6 | LD7 | LD8 | OC | OS | | |
| 436 | 0010110110 | IC29 Suction temperature | | | | | | | | | | | B | The unit is [°C] |
| 437 | 1010110110 | IC30 Suction temperature | | | | | | | | | | | | |
| 438 | 0110110110 | IC31 Suction temperature | | | | | | | | | | | | |
| 439 | 1110110110 | IC32 Suction temperature | | | | | | | | | | | | |
| 440 | 0001110110 | IC33 Suction temperature | | | | | | | | | | | | |
| 441 | 1001110110 | IC34 Suction temperature | | | | | | | | | | | | |
| 442 | 0101110110 | IC35 Suction temperature | | | | | | | | | | | | |
| 443 | 1101110110 | IC36 Suction temperature | | | | | | | | | | | | |
| 444 | 0011110110 | IC37 Suction temperature | | | | | | | | | | | | |
| 445 | 1011110110 | IC38 Suction temperature | | | | | | | | | | | | |
| 446 | 0111110110 | IC39 Suction temperature | | | | | | | | | | | | |
| 447 | 1111110110 | IC40 Suction temperature | | | | | | | | | | | | |
| 448 | 0000001110 | IC41 Suction temperature | | | | | | | | | | | | |
| 449 | 1000001110 | IC42 Suction temperature | | | | | | | | | | | | |
| 450 | 0100001110 | IC43 Suction temperature | | | | | | | | | | | | |
| 451 | 1100001110 | IC44 Suction temperature | | | | | | | | | | | | |
| 452 | 0010001110 | IC45 Suction temperature | | | | | | | | | | | | |
| 453 | 1010001110 | IC46 Suction temperature | | | | | | | | | | | | |
| 454 | 0110001110 | IC47 Suction temperature | | | | | | | | | | | | |
| 455 | 1110001110 | IC48 Suction temperature | | | | | | | | | | | | |
| 456 | 0001001110 | IC49 Suction temperature | | | | | | | | | | | | |
| 457 | 1001001110 | IC50 Suction temperature | | | | | | | | | | | | |
| 458 | 0101001110 | IC1 Liquid pipe temperature | | | | | | | | | | | B | The unit is [°C] |
| 459 | 1101001110 | IC2 Liquid pipe temperature | | | | | | | | | | | | |
| 460 | 0011001110 | IC3 Liquid pipe temperature | | | | | | | | | | | | |
| 461 | 1011001110 | IC4 Liquid pipe temperature | | | | | | | | | | | | |
| 462 | 0111001110 | IC5 Liquid pipe temperature | | | | | | | | | | | | |
| 463 | 1111001110 | IC6 Liquid pipe temperature | | | | | | | | | | | | |

*1 A: The condition of either OC or OS is displayed individually. B: The condition of the entire refrigerant system is displayed.

Data on indoor unit system

| No. | SW1 | Item | Display | | | | | | | | Unit (A, B) *1 | | Remarks | |
|-----|------------|------------------------------|---------|-----|-----|-----|-----|-----|-----|-----|----------------|----|---------|------------------|
| | | | LD1 | LD2 | LD3 | LD4 | LD5 | LD6 | LD7 | LD8 | OC | OS | | |
| 464 | 0000101110 | IC7 Liquid pipe temperature | | | | | | | | | | | | The unit is [°C] |
| 465 | 1000101110 | IC8 Liquid pipe temperature | | | | | | | | | | | | |
| 466 | 0100101110 | IC9 Liquid pipe temperature | | | | | | | | | | | | |
| 467 | 1100101110 | IC10 Liquid pipe temperature | | | | | | | | | | | | |
| 468 | 0010101110 | IC11 Liquid pipe temperature | | | | | | | | | | | | |
| 469 | 1010101110 | IC12 Liquid pipe temperature | | | | | | | | | | | | |
| 470 | 0110101110 | IC13 Liquid pipe temperature | | | | | | | | | | | | |
| 471 | 1110101110 | IC14 Liquid pipe temperature | | | | | | | | | | | | |
| 472 | 0001101110 | IC15 Liquid pipe temperature | | | | | | | | | | | | |
| 473 | 1001101110 | IC16 Liquid pipe temperature | | | | | | | | | | | | |
| 474 | 0101101110 | IC17 Liquid pipe temperature | | | | | | | | | | | | |
| 475 | 1101101110 | IC18 Liquid pipe temperature | | | | | | | | | | | | |
| 476 | 0011101110 | IC19 Liquid pipe temperature | | | | | | | | | | | | |
| 477 | 1011101110 | IC20 Liquid pipe temperature | | | | | | | | | | | | |
| 478 | 0111101110 | IC21 Liquid pipe temperature | | | | | | | | | | | | |
| 479 | 1111101110 | IC22 Liquid pipe temperature | | | | | | | | | | | | |
| 480 | 0000011110 | IC23 Liquid pipe temperature | | | | | | | | | | | | |
| 481 | 1000011110 | IC24 Liquid pipe temperature | | | | | | | | | | | | |
| 482 | 0100011110 | IC25 Liquid pipe temperature | | | | | | | | | | | | |
| 483 | 1100011110 | IC26 Liquid pipe temperature | | | | | | | | | | | | |
| 484 | 0010011110 | IC27 Liquid pipe temperature | | | | | | | | | | | | |
| 485 | 1010011110 | IC28 Liquid pipe temperature | | | | | | | | | | | | |
| 486 | 0110011110 | IC29 Liquid pipe temperature | | | | | | | | | | | | |
| 487 | 1110011110 | IC30 Liquid pipe temperature | | | | | | | | | | | | |
| 488 | 0001011110 | IC31 Liquid pipe temperature | | | | | | | | | | | | |
| 489 | 1001011110 | IC32 Liquid pipe temperature | | | | | | | | | | | | |
| 490 | 0101011110 | IC33 Liquid pipe temperature | | | | | | | | | | | | |
| 491 | 1101011110 | IC34 Liquid pipe temperature | | | | | | | | | | | | |

*1 A: The condition of either OC or OS is displayed individually. B: The condition of the entire refrigerant system is displayed.

Data on indoor unit system

| No. | SW1 | Item | Display | | | | | | | | Unit (A, B) *1 | | Remarks | |
|-----|------------|------------------------------|---------|-----|-----|-----|-----|-----|-----|-----|-------------------|----|---------|------------------|
| | | | LD1 | LD2 | LD3 | LD4 | LD5 | LD6 | LD7 | LD8 | OC | OS | | |
| 492 | 0011011110 | IC35 Liquid pipe temperature | | | | | | | | | | | | The unit is [°C] |
| 493 | 1011011110 | IC36 Liquid pipe temperature | | | | | | | | | | | | |
| 494 | 0111011110 | IC37 Liquid pipe temperature | | | | | | | | | | | | |
| 495 | 1111011110 | IC38 Liquid pipe temperature | | | | | | | | | | | | |
| 496 | 0000111110 | IC39 Liquid pipe temperature | | | | | | | | | | | | |
| 497 | 1000111110 | IC40 Liquid pipe temperature | | | | | | | | | | | | |
| 498 | 0100111110 | IC41 Liquid pipe temperature | | | | | | | | | | | | |
| 499 | 1100111110 | IC42 Liquid pipe temperature | | | | | | | | | | | | |
| 500 | 0010111110 | IC43 Liquid pipe temperature | | | | | | | | | | | | |
| 501 | 1010111110 | IC44 Liquid pipe temperature | | | | | | | | | | | | |
| 502 | 0110111110 | IC45 Liquid pipe temperature | | | | | | | | | | | | |
| 503 | 1110111110 | IC46 Liquid pipe temperature | | | | | | | | | | | | |
| 504 | 0001111110 | IC47 Liquid pipe temperature | | | | | | | | | | | | |
| 505 | 1001111110 | IC48 Liquid pipe temperature | | | | | | | | | | | | |
| 506 | 0101111110 | IC49 Liquid pipe temperature | | | | | | | | | | | | |
| 507 | 1101111110 | IC50 Liquid pipe temperature | | | | | | | | | | | | |
| 508 | 0011111110 | | | | | | | | | | | | | |
| 509 | 1011111110 | | | | | | | | | | | | | |
| 510 | 0111111110 | | | | | | | | | | | | | |
| 511 | 1111111110 | | | | | | | | | | | | | |

*1 A: The condition of either OC or OS is displayed individually. B: The condition of the entire refrigerant system is displayed.

Setting data

| No. | SW1 | Item | Display | | | | | | | | Unit (A, B) ^{*1} | | Remarks |
|-----|------------|------------------|--|-----|-----|-----|-----|-----|-----|-----|------------------------------|----|---------|
| | | | LD1 | LD2 | LD3 | LD4 | LD5 | LD6 | LD7 | LD8 | OC | OS | |
| 512 | 0000000001 | Self-address | Alternate display of self address and unit model | | | | | | | | A | A | |
| 513 | 1000000001 | IC/FU address | Count-up display of number of connected units | | | | | | | | B | | |
| 514 | 0100000001 | RC address | Count-up display of number of connected units | | | | | | | | B | | |
| 515 | 1100000001 | BC/BS/TU address | Count-up display of number of connected units | | | | | | | | | | |
| 516 | 0010000001 | OS address | Count-up display of number of connected units | | | | | | | | B | | |
| 517 | 1010000001 | Version/Capacity | S/W version -> Refrigerant type -> Model and capacity -> Communication address | | | | | | | | A | A | |
| 518 | 0110000001 | OC address | OC address display | | | | | | | | | B | |
| 519 | 1110000001 | | | | | | | | | | | | |
| 520 | 0001000001 | | | | | | | | | | | | |
| 521 | 1001000001 | | | | | | | | | | | | |
| 522 | 0101000001 | | | | | | | | | | | | |

*1 A: The condition of either OC or OS is displayed individually. B: The condition of the entire refrigerant system is displayed.

Data on indoor unit system

| No. | SW1 | Item | Display | | | | | | | | Unit (A, B) ^{*1} | | Remarks | | | |
|-----|------------|---------------------------|---------|-----|-----|-----|-----|-----|-----|-----|------------------------------|----|---------|---|--|------------------|
| | | | LD1 | LD2 | LD3 | LD4 | LD5 | LD6 | LD7 | LD8 | OC | OS | | | | |
| 523 | 1101000001 | IC1 Gas pipe temperature | | | | | | | | | | | | B | | The unit is [°C] |
| 524 | 0011000001 | IC2 Gas pipe temperature | | | | | | | | | | | | | | |
| 525 | 1011000001 | IC3 Gas pipe temperature | | | | | | | | | | | | | | |
| 526 | 0111000001 | IC4 Gas pipe temperature | | | | | | | | | | | | | | |
| 527 | 1111000001 | IC5 Gas pipe temperature | | | | | | | | | | | | | | |
| 528 | 0000100001 | IC6 Gas pipe temperature | | | | | | | | | | | | | | |
| 529 | 1000100001 | IC7 Gas pipe temperature | | | | | | | | | | | | | | |
| 530 | 0100100001 | IC8 Gas pipe temperature | | | | | | | | | | | | | | |
| 531 | 1100100001 | IC9 Gas pipe temperature | | | | | | | | | | | | | | |
| 532 | 0010100001 | IC10 Gas pipe temperature | | | | | | | | | | | | | | |
| 533 | 1010100001 | IC11 Gas pipe temperature | | | | | | | | | | | | | | |
| 534 | 0110100001 | IC12 Gas pipe temperature | | | | | | | | | | | | | | |
| 535 | 1110100001 | IC13 Gas pipe temperature | | | | | | | | | | | | | | |
| 536 | 0001100001 | IC14 Gas pipe temperature | | | | | | | | | | | | | | |
| 537 | 1001100001 | IC15 Gas pipe temperature | | | | | | | | | | | | | | |
| 538 | 0101100001 | IC16 Gas pipe temperature | | | | | | | | | | | | | | |
| 539 | 1101100001 | IC17 Gas pipe temperature | | | | | | | | | | | | | | |
| 540 | 0011100001 | IC18 Gas pipe temperature | | | | | | | | | | | | | | |
| 541 | 1011100001 | IC19 Gas pipe temperature | | | | | | | | | | | | | | |
| 542 | 0111100001 | IC20 Gas pipe temperature | | | | | | | | | | | | | | |
| 543 | 1111100001 | IC21 Gas pipe temperature | | | | | | | | | | | | | | |
| 544 | 0000010001 | IC22 Gas pipe temperature | | | | | | | | | | | | | | |
| 545 | 1000010001 | IC23 Gas pipe temperature | | | | | | | | | | | | | | |
| 546 | 0100010001 | IC24 Gas pipe temperature | | | | | | | | | | | | | | |
| 547 | 1100010001 | IC25 Gas pipe temperature | | | | | | | | | | | | | | |
| 548 | 0010010001 | IC26 Gas pipe temperature | | | | | | | | | | | | | | |
| 549 | 1010010001 | IC27 Gas pipe temperature | | | | | | | | | | | | | | |

*1 A: The condition of either OC or OS is displayed individually. B: The condition of the entire refrigerant system is displayed.

Data on indoor unit system

| No. | SW1 | Item | Display | | | | | | | | | | Unit (A, B) *1 | | Remarks | | |
|-----|------------|---------------------------|---------|-----|-----|-----|-----|-----|-----|-----|----|----|----------------|--|---------|--|------------------|
| | | | LD1 | LD2 | LD3 | LD4 | LD5 | LD6 | LD7 | LD8 | OC | OS | | | | | |
| 550 | 1234567890 | IC28 Gas pipe temperature | | | | | | | | | | | | | | | The unit is [°C] |
| 551 | 0110010001 | IC29 Gas pipe temperature | | | | | | | | | | | | | | | |
| 552 | 1110010001 | IC30 Gas pipe temperature | | | | | | | | | | | | | | | |
| 553 | 0001010001 | IC31 Gas pipe temperature | | | | | | | | | | | | | | | |
| 554 | 1001010001 | IC32 Gas pipe temperature | | | | | | | | | | | | | | | |
| 555 | 0101010001 | IC33 Gas pipe temperature | | | | | | | | | | | | | | | |
| 556 | 1101010001 | IC34 Gas pipe temperature | | | | | | | | | | | | | | | |
| 557 | 0011010001 | IC35 Gas pipe temperature | | | | | | | | | | | | | | | |
| 558 | 1011010001 | IC36 Gas pipe temperature | | | | | | | | | | | | | | | |
| 559 | 0111010001 | IC37 Gas pipe temperature | | | | | | | | | | | | | | | |
| 560 | 1111010001 | IC38 Gas pipe temperature | | | | | | | | | | | | | | | |
| 561 | 0000110001 | IC39 Gas pipe temperature | | | | | | | | | | | | | | | |
| 562 | 1000110001 | IC40 Gas pipe temperature | | | | | | | | | | | | | | | |
| 563 | 0100110001 | IC41 Gas pipe temperature | | | | | | | | | | | | | | | |
| 564 | 1100110001 | IC42 Gas pipe temperature | | | | | | | | | | | | | | | |
| 565 | 0010110001 | IC43 Gas pipe temperature | | | | | | | | | | | | | | | |
| 566 | 1010110001 | IC44 Gas pipe temperature | | | | | | | | | | | | | | | |
| 567 | 0110110001 | IC45 Gas pipe temperature | | | | | | | | | | | | | | | |
| 568 | 1110110001 | IC46 Gas pipe temperature | | | | | | | | | | | | | | | |
| 569 | 0001110001 | IC47 Gas pipe temperature | | | | | | | | | | | | | | | |
| 570 | 1001110001 | IC48 Gas pipe temperature | | | | | | | | | | | | | | | |
| 571 | 0101110001 | IC49 Gas pipe temperature | | | | | | | | | | | | | | | |
| 572 | 1101110001 | IC50 Gas pipe temperature | | | | | | | | | | | | | | | |

*1 A: The condition of either OC or OS is displayed individually. B: The condition of the entire refrigerant system is displayed.

Data on indoor unit system

| No. | SW1 | Item | Display | | | | | | | | Unit (A, B) ^{*1} | | Remarks | |
|-----|------------|--------|---------|-----|-----|-----|-----|-----|-----|-----|------------------------------|----|---------|--------------------|
| | | | LD1 | LD2 | LD3 | LD4 | LD5 | LD6 | LD7 | LD8 | OC | OS | | |
| 573 | 1011110001 | IC1SH | | | | | | | | | | | | The unit is [°C] |
| 574 | 0111110001 | IC2SH | | | | | | | | | | | | |
| 575 | 1111110001 | IC3SH | | | | | | | | | | | | |
| 576 | 000001001 | IC4SH | | | | | | | | | | | | |
| 577 | 100001001 | IC5SH | | | | | | | | | | | | |
| 578 | 010001001 | IC6SH | | | | | | | | | | | | |
| 579 | 110001001 | IC7SH | | | | | | | | | | | | |
| 580 | 0010001001 | IC8SH | | | | | | | | | | | | |
| 581 | 1010001001 | IC9SH | | | | | | | | | | | | |
| 582 | 0110001001 | IC10SH | | | | | | | | | | | | |
| 583 | 1110001001 | IC11SH | | | | | | | | | | | | |
| 584 | 0001001001 | IC12SH | | | | | | | | | | | | |
| 585 | 1001001001 | IC13SH | | | | | | | | | | | | |
| 586 | 0101001001 | IC14SH | | | | | | | | | | | | |
| 587 | 1101001001 | IC15SH | | | | | | | | | | | | |
| 588 | 0011001001 | IC16SH | | | | | | | | | | | | |
| 589 | 1011001001 | IC17SH | | | | | | | | | | | | |
| 590 | 0111001001 | IC18SH | | | | | | | | | | | | |
| 591 | 1111001001 | IC19SH | | | | | | | | | | | | |
| 592 | 0000101001 | IC20SH | | | | | | | | | | | | |
| 593 | 1000101001 | IC21SH | | | | | | | | | | | | |
| 594 | 0100101001 | IC22SH | | | | | | | | | | | | |
| 595 | 1100101001 | IC23SH | | | | | | | | | | | | |
| 596 | 0010101001 | IC24SH | | | | | | | | | | | | |
| 597 | 1010101001 | IC25SH | | | | | | | | | | | | |
| 598 | 0110101001 | IC26SH | | | | | | | | | | | | |
| 599 | 1110101001 | IC27SH | | | | | | | | | | | | |

*1 A: The condition of either OC or OS is displayed individually. B: The condition of the entire refrigerant system is displayed.

Data on indoor unit system

| No. | SW1 | Item | Display | | | | | | | | Unit (A, B) ^{*1} | | Remarks | |
|-----|------------|--------|---------|-----|-----|-----|-----|-----|-----|-----|------------------------------|----|---------|--------------------|
| | | | LD1 | LD2 | LD3 | LD4 | LD5 | LD6 | LD7 | LD8 | OC | OS | | |
| 600 | 0001101001 | IC28SH | | | | | | | | | | | | The unit is [°C] |
| 601 | 1001101001 | IC29SH | | | | | | | | | | | | |
| 602 | 0101101001 | IC30SH | | | | | | | | | | | | |
| 603 | 1101101001 | IC31SH | | | | | | | | | | | | |
| 604 | 0011101001 | IC32SH | | | | | | | | | | | | |
| 605 | 1011101001 | IC33SH | | | | | | | | | | | | |
| 606 | 0111101001 | IC34SH | | | | | | | | | | | | |
| 607 | 1111101001 | IC35SH | | | | | | | | | | | | |
| 608 | 0000011001 | IC36SH | | | | | | | | | | | | |
| 609 | 1000011001 | IC37SH | | | | | | | | | | | | |
| 610 | 0100011001 | IC38SH | | | | | | | | | | | | |
| 611 | 1100011001 | IC39SH | | | | | | | | | | | | |
| 612 | 0010011001 | IC40SH | | | | | | | | | | | | |
| 613 | 1010011001 | IC41SH | | | | | | | | | | | | |
| 614 | 0110011001 | IC42SH | | | | | | | | | | | | |
| 615 | 1110011001 | IC43SH | | | | | | | | | | | | |
| 616 | 0001011001 | IC44SH | | | | | | | | | | | | |
| 617 | 1001011001 | IC45SH | | | | | | | | | | | | |
| 618 | 0101011001 | IC46SH | | | | | | | | | | | | |
| 619 | 1101011001 | IC47SH | | | | | | | | | | | | |
| 620 | 0011011001 | IC48SH | | | | | | | | | | | | |
| 621 | 1011011001 | IC49SH | | | | | | | | | | | | |
| 622 | 0111011001 | IC50SH | | | | | | | | | | | | |

*1 A: The condition of either OC or OS is displayed individually. B: The condition of the entire refrigerant system is displayed.

Data on indoor unit system

| No. | SW1 | Item | Display | | | | | | | | Unit (A, B) ^{*1} | | Remarks | |
|-----|------------|--------|---------|-----|-----|-----|-----|-----|-----|-----|------------------------------|----|---------|--------------------|
| | | | LD1 | LD2 | LD3 | LD4 | LD5 | LD6 | LD7 | LD8 | OC | OS | | |
| 623 | 1111011001 | IC1SC | | | | | | | | | | | | The unit is [°C] |
| 624 | 0000111001 | IC2SC | | | | | | | | | | | | |
| 625 | 1000111001 | IC3SC | | | | | | | | | | | | |
| 626 | 0100111001 | IC4SC | | | | | | | | | | | | |
| 627 | 1100111001 | IC5SC | | | | | | | | | | | | |
| 628 | 0010111001 | IC6SC | | | | | | | | | | | | |
| 629 | 1010111001 | IC7SC | | | | | | | | | | | | |
| 630 | 0110111001 | IC8SC | | | | | | | | | | | | |
| 631 | 1110111001 | IC9SC | | | | | | | | | | | | |
| 632 | 0001111001 | IC10SC | | | | | | | | | | | | |
| 633 | 1001111001 | IC11SC | | | | | | | | | | | | |
| 634 | 0101111001 | IC12SC | | | | | | | | | | | | |
| 635 | 1101111001 | IC13SC | | | | | | | | | | | | |
| 636 | 0011111001 | IC14SC | | | | | | | | | | | | |
| 637 | 1011111001 | IC15SC | | | | | | | | | | | | |
| 638 | 0111111001 | IC16SC | | | | | | | | | | | | |
| 639 | 1111111001 | IC17SC | | | | | | | | | | | | |
| 640 | 0000000101 | IC18SC | | | | | | | | | | | | |
| 641 | 1000000101 | IC19SC | | | | | | | | | | | | |
| 642 | 0100000101 | IC20SC | | | | | | | | | | | | |
| 643 | 1100000101 | IC21SC | | | | | | | | | | | | |
| 644 | 0010000101 | IC22SC | | | | | | | | | | | | |
| 645 | 1010000101 | IC23SC | | | | | | | | | | | | |
| 646 | 0110000101 | IC24SC | | | | | | | | | | | | |
| 647 | 1110000101 | IC25SC | | | | | | | | | | | | |
| 648 | 0001000101 | IC26SC | | | | | | | | | | | | |
| 649 | 1001000101 | IC27SC | | | | | | | | | | | | |

*1 A: The condition of either OC or OS is displayed individually. B: The condition of the entire refrigerant system is displayed.

Data on indoor unit system

| No. | SW1 | Item | Display | | | | | | | | Unit (A, B) ^{*1} | | Remarks | |
|-----|------------|--------|---------|-----|-----|-----|-----|-----|-----|-----|---------------------------|----|---------|--------------------|
| | | | LD1 | LD2 | LD3 | LD4 | LD5 | LD6 | LD7 | LD8 | OC | OS | | |
| 650 | 0101000101 | IC28SC | | | | | | | | | | | | The unit is [°C] |
| 651 | 1101000101 | IC29SC | | | | | | | | | | | | |
| 652 | 0011000101 | IC30SC | | | | | | | | | | | | |
| 653 | 1011000101 | IC31SC | | | | | | | | | | | | |
| 654 | 0111000101 | IC32SC | | | | | | | | | | | | |
| 655 | 1111000101 | IC33SC | | | | | | | | | | | | |
| 656 | 0000100101 | IC34SC | | | | | | | | | | | | |
| 657 | 1000100101 | IC35SC | | | | | | | | | | | | |
| 658 | 0100100101 | IC36SC | | | | | | | | | | | | |
| 659 | 1100100101 | IC37SC | | | | | | | | | | | | |
| 660 | 0010100101 | IC38SC | | | | | | | | | | | | |
| 661 | 1010100101 | IC39SC | | | | | | | | | | | | |
| 662 | 0110100101 | IC40SC | | | | | | | | | | | | |
| 663 | 1110100101 | IC41SC | | | | | | | | | | | | |
| 664 | 0001100101 | IC42SC | | | | | | | | | | | | |
| 665 | 1001100101 | IC43SC | | | | | | | | | | | | |
| 666 | 0101100101 | IC44SC | | | | | | | | | | | | |
| 667 | 1101100101 | IC45SC | | | | | | | | | | | | |
| 668 | 0011100101 | IC46SC | | | | | | | | | | | | |
| 669 | 1011100101 | IC47SC | | | | | | | | | | | | |
| 670 | 0111100101 | IC48SC | | | | | | | | | | | | |
| 671 | 1111100101 | IC49SC | | | | | | | | | | | | |
| 672 | 0000010101 | IC50SC | | | | | | | | | | | | |
| 673 | 1000010101 | | | | | | | | | | | | | |
| 674 | 0100010101 | | | | | | | | | | | | | |
| 675 | 1100010101 | | | | | | | | | | | | | |

*1 A: The condition of either OC or OS is displayed individually. B: The condition of the entire refrigerant system is displayed.

Setting data

| No. | SW1 | Item | Display | | | | | | | | Unit (A, B)*1 | | Remarks | |
|-----|------------|-----------------------|---------|-----|-----|-----|-----|-----|-----|-----|---------------|----|---------|--|
| | | | LD1 | LD2 | LD3 | LD4 | LD5 | LD6 | LD7 | LD8 | OC | OS | | |
| 676 | 0010010101 | INV board S/W version | | | | | | | | | | A | A | |
| 677 | 1010010101 | | | | | | | | | | | | | |
| 678 | 0110010101 | | | | | | | | | | | | | |
| 679 | 1110010101 | Fan board S/W version | | | | | | | | | | A | A | |
| 680 | 0001010101 | | | | | | | | | | | | | |
| 681 | 1001010101 | | | | | | | | | | | | | |
| 682 | 0101010101 | | | | | | | | | | | | | |
| 683 | 1101010101 | | | | | | | | | | | | | |
| 684 | 0011010101 | | | | | | | | | | | | | |
| 685 | 1011010101 | | | | | | | | | | | | | |
| 686 | 0111010101 | | | | | | | | | | | | | |
| 687 | 1111010101 | | | | | | | | | | | | | |

*1 A: The condition of either OC or OS is displayed individually. B: The condition of the entire refrigerant system is displayed.

Setting data

| No. | SW1 | Item | Display | | | | | | | | Unit (A, B)*1 | | Remarks |
|-----|------------|-----------------------------|------------------------|-----|-----|-----|-----|-----|-----|-----|---------------|----|--|
| | | | LD1 | LD2 | LD3 | LD4 | LD5 | LD6 | LD7 | LD8 | OC | OS | |
| 688 | 0000110101 | Current time | 00:00 to 23:59 | | | | | | | | A | A | Hour: minute |
| 689 | 1000110101 | Current time -2 | 00.00 to 99.12/1 to 31 | | | | | | | | | | Year and month, and date alternate display |
| 690 | 0100110101 | Time of error detection 1 | 00:00 to 23:59 | | | | | | | | | | Hour: minute |
| 691 | 1100110101 | Time of error detection 1-2 | 00.00 to 99.12/1 to 31 | | | | | | | | | | Year and month, and date alternate display |
| 692 | 0010110101 | Time of error detection 2 | 00:00 to 23:59 | | | | | | | | | | Hour: minute |
| 693 | 1010110101 | Time of error detection 2-2 | 00.00 to 99.12/1 to 31 | | | | | | | | | | Year and month, and date alternate display |
| 694 | 0110110101 | Time of error detection 3 | 00:00 to 23:59 | | | | | | | | | | Hour: minute |
| 695 | 1110110101 | Time of error detection 3-2 | 00.00 to 99.12/1 to 31 | | | | | | | | | | Year and month, and date alternate display |
| 696 | 0001110101 | Time of error detection 4 | 00:00 to 23:59 | | | | | | | | | | Hour: minute |
| 697 | 1001110101 | Time of error detection 4-2 | 00.00 to 99.12/1 to 31 | | | | | | | | | | Year and month, and date alternate display |
| 698 | 0101110101 | Time of error detection 5 | 00:00 to 23:59 | | | | | | | | | | Hour: minute |
| 699 | 1101110101 | Time of error detection 5-2 | 00.00 to 99.12/1 to 31 | | | | | | | | | | Year and month, and date alternate display |
| 700 | 0011110101 | Time of error detection 6 | 00:00 to 23:59 | | | | | | | | | | Hour: minute |
| 701 | 1011110101 | Time of error detection 6-2 | 00.00 to 99.12/1 to 31 | | | | | | | | | | Year and month, and date alternate display |

*1 A: The condition of either OC or OS is displayed individually. B: The condition of the entire refrigerant system is displayed.

Setting data

| No. | SW1 | Item | Display | | | | | | | | Unit (A, B)*1 | | Remarks |
|-----|------------|--|------------------------|-----|-----|-----|-----|-----|-----|-----|------------------|----|--|
| | | | LD1 | LD2 | LD3 | LD4 | LD5 | LD6 | LD7 | LD8 | OC | OS | |
| 702 | 0111110101 | Time of error detection 7 | 00:00 to 23:59 | | | | | | | | A | A | Hour: minute |
| 703 | 1111110101 | Time of error detection 7-2 | 00.00 to 99.12/1 to 31 | | | | | | | | | | Year and month, and date alternate display |
| 704 | 0000001101 | Time of error detection 8 | 00:00 to 23:59 | | | | | | | | | | Hour: minute |
| 705 | 1000001101 | Time of error detection 8-2 | 00.00 to 99.12/1 to 31 | | | | | | | | | | Year and month, and date alternate display |
| 706 | 0100001101 | Time of error detection 9 | 00:00 to 23:59 | | | | | | | | | | Hour: minute |
| 707 | 1100001101 | Time of error detection 9-2 | 00.00 to 99.12/1 to 31 | | | | | | | | | | Year and month, and date alternate display |
| 708 | 0010001101 | Time of error detection 10 | 00:00 to 23:59 | | | | | | | | | | Hour: minute |
| 709 | 1010001101 | Time of error detection 10-2 | 00.00 to 99.12/1 to 31 | | | | | | | | | | Year and month, and date alternate display |
| 710 | 0110001101 | Time of last data backup before error | 00:00 to 23:59 | | | | | | | | | | Hour: minute |
| 711 | 1110001101 | Time of last data backup before error -2 | 00.00 to 99.12/1 to 31 | | | | | | | | | | Year and month, and date alternate display |
| 712 | 0001001101 | | | | | | | | | | | | |
| 713 | 1001001101 | | | | | | | | | | | | |

*1 A: The condition of either OC or OS is displayed individually. B: The condition of the entire refrigerant system is displayed.

Data on indoor unit system

| No. | SW1 | Item | Display | | | | | | | | Unit (A, B) * 1 | | Remarks |
|-----|------------|------------------|--------------|-----|-----|-----|-----|-----|-----|-----|-----------------|----|------------------|
| | | | LD1 | LD2 | LD3 | LD4 | LD5 | LD6 | LD7 | LD8 | OC | OS | |
| 714 | 0101001101 | IC1 LEV opening | 0000 to 9999 | | | | | | | | B | | Fully open: 2000 |
| 715 | 1101001101 | IC2 LEV opening | 0000 to 9999 | | | | | | | | | | |
| 716 | 0011001101 | IC3 LEV opening | 0000 to 9999 | | | | | | | | | | |
| 717 | 1011001101 | IC4 LEV opening | 0000 to 9999 | | | | | | | | | | |
| 718 | 0111001101 | IC5 LEV opening | 0000 to 9999 | | | | | | | | | | |
| 719 | 1111001101 | IC6 LEV opening | 0000 to 9999 | | | | | | | | | | |
| 720 | 0000101101 | IC7 LEV opening | 0000 to 9999 | | | | | | | | | | |
| 721 | 1000101101 | IC8 LEV opening | 0000 to 9999 | | | | | | | | | | |
| 722 | 0100101101 | IC9 LEV opening | 0000 to 9999 | | | | | | | | | | |
| 723 | 1100101101 | IC10 LEV opening | 0000 to 9999 | | | | | | | | | | |
| 724 | 0010101101 | IC11 LEV opening | 0000 to 9999 | | | | | | | | | | |
| 725 | 1010101101 | IC12 LEV opening | 0000 to 9999 | | | | | | | | | | |
| 726 | 0110101101 | IC13 LEV opening | 0000 to 9999 | | | | | | | | | | |
| 727 | 1110101101 | IC14 LEV opening | 0000 to 9999 | | | | | | | | | | |
| 728 | 0001101101 | IC15 LEV opening | 0000 to 9999 | | | | | | | | | | |
| 729 | 1001101101 | IC16 LEV opening | 0000 to 9999 | | | | | | | | | | |
| 730 | 0101101101 | IC17 LEV opening | 0000 to 9999 | | | | | | | | | | |
| 731 | 1101101101 | IC18 LEV opening | 0000 to 9999 | | | | | | | | | | |
| 732 | 0011101101 | IC19 LEV opening | 0000 to 9999 | | | | | | | | | | |
| 733 | 1011101101 | IC20 LEV opening | 0000 to 9999 | | | | | | | | | | |
| 734 | 0111101101 | IC21 LEV opening | 0000 to 9999 | | | | | | | | | | |
| 735 | 1111101101 | IC22 LEV opening | 0000 to 9999 | | | | | | | | | | |
| 736 | 0000011101 | IC23 LEV opening | 0000 to 9999 | | | | | | | | | | |
| 737 | 1000011101 | IC24 LEV opening | 0000 to 9999 | | | | | | | | | | |
| 738 | 0100011101 | IC25 LEV opening | 0000 to 9999 | | | | | | | | | | |
| 739 | 1100011101 | IC26 LEV opening | 0000 to 9999 | | | | | | | | | | |
| 740 | 0010011101 | IC27 LEV opening | 0000 to 9999 | | | | | | | | | | |

*1 A: The condition of either OC or OS is displayed individually. B: The condition of the entire refrigerant system is displayed.

Data on indoor unit system

| No. | SW1 | Item | Display | | | | | | | | Unit (A, B) *1 | | Remarks |
|-----|------------|--------------------|---|-----|-----|-----|-----|-----|-----|-----|----------------|----|------------------|
| | | | LD1 | LD2 | LD3 | LD4 | LD5 | LD6 | LD7 | LD8 | OC | OS | |
| 741 | 1010011101 | IC28 LEV opening | 0000 to 9999 | | | | | | | | B | | Fully open: 2000 |
| 742 | 0110011101 | IC29 LEV opening | 0000 to 9999 | | | | | | | | | | |
| 743 | 1110011101 | IC30 LEV opening | 0000 to 9999 | | | | | | | | | | |
| 744 | 0001011101 | IC31 LEV opening | 0000 to 9999 | | | | | | | | | | |
| 745 | 1001011101 | IC32 LEV opening | 0000 to 9999 | | | | | | | | | | |
| 746 | 0101011101 | IC33 LEV opening | 0000 to 9999 | | | | | | | | | | |
| 747 | 1101011101 | IC34 LEV opening | 0000 to 9999 | | | | | | | | | | |
| 748 | 0011011101 | IC35 LEV opening | 0000 to 9999 | | | | | | | | | | |
| 749 | 1011011101 | IC36 LEV opening | 0000 to 9999 | | | | | | | | | | |
| 750 | 0111011101 | IC37 LEV opening | 0000 to 9999 | | | | | | | | | | |
| 751 | 1111011101 | IC38 LEV opening | 0000 to 9999 | | | | | | | | | | |
| 752 | 0000111101 | IC39 LEV opening | 0000 to 9999 | | | | | | | | | | |
| 753 | 1000111101 | IC40 LEV opening | 0000 to 9999 | | | | | | | | | | |
| 754 | 0100111101 | IC41 LEV opening | 0000 to 9999 | | | | | | | | | | |
| 755 | 1100111101 | IC42 LEV opening | 0000 to 9999 | | | | | | | | | | |
| 756 | 0010111101 | IC43 LEV opening | 0000 to 9999 | | | | | | | | | | |
| 757 | 1010111101 | IC44 LEV opening | 0000 to 9999 | | | | | | | | | | |
| 758 | 0110111101 | IC45 LEV opening | 0000 to 9999 | | | | | | | | | | |
| 759 | 1110111101 | IC46 LEV opening | 0000 to 9999 | | | | | | | | | | |
| 760 | 0001111101 | IC47 LEV opening | 0000 to 9999 | | | | | | | | | | |
| 761 | 1001111101 | IC48 LEV opening | 0000 to 9999 | | | | | | | | | | |
| 762 | 0101111101 | IC49 LEV opening | 0000 to 9999 | | | | | | | | | | |
| 763 | 1101111101 | IC50 LEV opening | 0000 to 9999 | | | | | | | | | | |
| 764 | 0011111101 | IC1 Operation mode | 0000 : Stop 0001 : Ventilation 0002 : Cooling 0003 : Heating 0004 : Dry | | | | | | | | B | | |
| 765 | 1011111101 | IC2 Operation mode | | | | | | | | | | | |
| 766 | 0111111101 | IC3 Operation mode | | | | | | | | | | | |
| 767 | 1111111101 | IC4 Operation mode | | | | | | | | | | | |
| 768 | 0000000011 | IC5 Operation mode | | | | | | | | | | | |

*1 A: The condition of either OC or OS is displayed individually. B: The condition of the entire refrigerant system is displayed.

Data on indoor unit system

| No. | SW1 | Item | Display | | | | | | | | Unit (A, B) *1 | | Remarks | | |
|-----|------------|---------------------|---------|-----|-----|-----|-----|-----|-----|-----|----------------|----|---------|--|--|
| | | | LD1 | LD2 | LD3 | LD4 | LD5 | LD6 | LD7 | LD8 | OC | OS | | | |
| 769 | 1000000011 | IC6 Operation mode | | | | | | | | | | | B | | |
| 770 | 0100000011 | IC7 Operation mode | | | | | | | | | | | | | |
| 771 | 1100000011 | IC8 Operation mode | | | | | | | | | | | | | |
| 772 | 0010000011 | IC9 Operation mode | | | | | | | | | | | | | |
| 773 | 1010000011 | IC10 Operation mode | | | | | | | | | | | | | |
| 774 | 0110000011 | IC11 Operation mode | | | | | | | | | | | | | |
| 775 | 1110000011 | IC12 Operation mode | | | | | | | | | | | | | |
| 776 | 0001000011 | IC13 Operation mode | | | | | | | | | | | | | |
| 777 | 1001000011 | IC14 Operation mode | | | | | | | | | | | | | |
| 778 | 0101000011 | IC15 Operation mode | | | | | | | | | | | | | |
| 779 | 1101000011 | IC16 Operation mode | | | | | | | | | | | | | |
| 780 | 0011000011 | IC17 Operation mode | | | | | | | | | | | | | |
| 781 | 1011000011 | IC18 Operation mode | | | | | | | | | | | | | |
| 782 | 0111000011 | IC19 Operation mode | | | | | | | | | | | | | |
| 783 | 1111000011 | IC20 Operation mode | | | | | | | | | | | | | |
| 784 | 0000100011 | IC21 Operation mode | | | | | | | | | | | | | |
| 785 | 1000100011 | IC22 Operation mode | | | | | | | | | | | | | |
| 786 | 0100100011 | IC23 Operation mode | | | | | | | | | | | | | |
| 787 | 1100100011 | IC24 Operation mode | | | | | | | | | | | | | |
| 788 | 0010100011 | IC25 Operation mode | | | | | | | | | | | | | |
| 789 | 1010100011 | IC26 Operation mode | | | | | | | | | | | | | |
| 790 | 0110100011 | IC27 Operation mode | | | | | | | | | | | | | |
| 791 | 1110100011 | IC28 Operation mode | | | | | | | | | | | | | |
| 792 | 0001100011 | IC29 Operation mode | | | | | | | | | | | | | |
| 793 | 1001100011 | IC30 Operation mode | | | | | | | | | | | | | |
| 794 | 0101100011 | IC31 Operation mode | | | | | | | | | | | | | |
| 795 | 1101100011 | IC32 Operation mode | | | | | | | | | | | | | |
| 796 | 0011100011 | IC33 Operation mode | | | | | | | | | | | | | |

0000 : Stop 0001 : Ventilation 0002 : Cooling 0003 : Heating 0004 : Dry

*1 A: The condition of either OC or OS is displayed individually. B: The condition of the entire refrigerant system is displayed.

Data on indoor unit system

| No. | SW1 | Item | Display | | | | | | | | Unit (A, B) *1 | | Remarks | |
|-----|------------|---------------------|---------|-----|-----|-----|-----|-----|-----|-----|----------------|----|---------|------------------------------------|
| | | | LD1 | LD2 | LD3 | LD4 | LD5 | LD6 | LD7 | LD8 | OC | OS | | |
| 797 | 1011100011 | IC34 Operation mode | | | | | | | | | | B | | |
| 798 | 0111100011 | IC35 Operation mode | | | | | | | | | | | | |
| 799 | 1111100011 | IC36 Operation mode | | | | | | | | | | | | |
| 800 | 0000010011 | IC37 Operation mode | | | | | | | | | | | | |
| 801 | 1000010011 | IC38 Operation mode | | | | | | | | | | | | |
| 802 | 0100010011 | IC39 Operation mode | | | | | | | | | | | | |
| 803 | 1100010011 | IC40 Operation mode | | | | | | | | | | | | |
| 804 | 0010010011 | IC41 Operation mode | | | | | | | | | | | | |
| 805 | 1010010011 | IC42 Operation mode | | | | | | | | | | | | |
| 806 | 0110010011 | IC43 Operation mode | | | | | | | | | | | | |
| 807 | 1110010011 | IC44 Operation mode | | | | | | | | | | | | |
| 808 | 0001010011 | IC45 Operation mode | | | | | | | | | | | | |
| 809 | 1001010011 | IC46 Operation mode | | | | | | | | | | | | |
| 810 | 0101010011 | IC47 Operation mode | | | | | | | | | | | | |
| 811 | 1101010011 | IC48 Operation mode | | | | | | | | | | | | |
| 812 | 0011010011 | IC49 Operation mode | | | | | | | | | | | | |
| 813 | 1011010011 | IC50 Operation mode | | | | | | | | | | | | |
| 814 | 0111010011 | IC1 filter | | | | | | | | | | | | Hours since last maintenance [h] |
| 815 | 1111010011 | IC2 filter | | | | | | | | | | | | |
| 816 | 0000110011 | IC3 filter | | | | | | | | | | | | |
| 817 | 1000110011 | IC4 filter | | | | | | | | | | | | |
| 818 | 0100110011 | IC5 filter | | | | | | | | | | | | |
| 819 | 1100110011 | IC6 filter | | | | | | | | | | | | |
| 820 | 0010110011 | IC7 filter | | | | | | | | | | | | |
| 821 | 1010110011 | IC8 filter | | | | | | | | | | | | |
| 822 | 0110110011 | IC9 filter | | | | | | | | | | | | |
| 823 | 1110110011 | IC10 filter | | | | | | | | | | | | |
| 824 | 0001110011 | IC11 filter | | | | | | | | | | | | |

0000 : Stop 0001 : Ventilation 0002 : Cooling 0003 : Heating 0004 : Dry

0000 to 9999
 0000 to 9999
 0000 to 9999
 0000 to 9999
 0000 to 9999
 0000 to 9999
 0000 to 9999
 0000 to 9999
 0000 to 9999
 0000 to 9999
 0000 to 9999

*1 A: The condition of either OC or OS is displayed individually. B: The condition of the entire refrigerant system is displayed.

Data on indoor unit system

| No. | SW1 | Item | Display | | | | | | | | Unit (A, B) *1 | | Remarks | |
|-----|------------|-------------|---------|-----|-----|-----|-----|-----|-----|-----|----------------|----|---------|------------------------------------|
| | | | LD1 | LD2 | LD3 | LD4 | LD5 | LD6 | LD7 | LD8 | OC | OS | | |
| 825 | 1001110011 | IC12 filter | | | | | | | | | | | | Hours since last maintenance [h] |
| 826 | 0101110011 | IC13 filter | | | | | | | | | | | | |
| 827 | 1101110011 | IC14 filter | | | | | | | | | | | | |
| 828 | 0011110011 | IC15 filter | | | | | | | | | | | | |
| 829 | 1011110011 | IC16 filter | | | | | | | | | | | | |
| 830 | 0111110011 | IC17 filter | | | | | | | | | | | | |
| 831 | 1111110011 | IC18 filter | | | | | | | | | | | | |
| 832 | 0000001011 | IC19 filter | | | | | | | | | | | | |
| 833 | 1000001011 | IC20 filter | | | | | | | | | | | | |
| 834 | 0100001011 | IC21 filter | | | | | | | | | | | | |
| 835 | 1100001011 | IC22 filter | | | | | | | | | | | | |
| 836 | 0010001011 | IC23 filter | | | | | | | | | | | | |
| 837 | 1010001011 | IC24 filter | | | | | | | | | | | | |
| 838 | 0110001011 | IC25 filter | | | | | | | | | | | | |
| 839 | 1110001011 | IC26 filter | | | | | | | | | | | | |
| 840 | 0001001011 | IC27 filter | | | | | | | | | | | | |
| 841 | 1001001011 | IC28 filter | | | | | | | | | | | | |
| 842 | 0101001011 | IC29 filter | | | | | | | | | | | | |
| 843 | 1101001011 | IC30 filter | | | | | | | | | | | | |
| 844 | 0011001011 | IC31 filter | | | | | | | | | | | | |
| 845 | 1011001011 | IC32 filter | | | | | | | | | | | | |
| 846 | 0111001001 | IC33 filter | | | | | | | | | | | | |
| 847 | 1111001011 | IC34 filter | | | | | | | | | | | | |
| 848 | 0000101011 | IC35 filter | | | | | | | | | | | | |
| 849 | 1000101011 | IC36 filter | | | | | | | | | | | | |
| 850 | 0100101011 | IC37 filter | | | | | | | | | | | | |
| 851 | 1100101011 | IC38 filter | | | | | | | | | | | | |
| 852 | 0010101011 | IC39 filter | | | | | | | | | | | | |

*1 A: The condition of either OC or OS is displayed individually. B: The condition of the entire refrigerant system is displayed.

Data on indoor unit system

| No. | SW1 1234567890 | Item | Display | | | | | | | | Unit (A, B) ^{*1} | | Remarks |
|-----|-------------------|-------------|--------------|-----|-----|-----|-----|-----|-----|-----|------------------------------|----|------------------------------------|
| | | | LD1 | LD2 | LD3 | LD4 | LD5 | LD6 | LD7 | LD8 | OC | OS | |
| 853 | 1010101011 | IC40 filter | 0000 to 9999 | | | | | | | | B | | Hours since last maintenance [h] |
| 854 | 0110101011 | IC41 filter | 0000 to 9999 | | | | | | | | | | |
| 855 | 1110101011 | IC42 filter | 0000 to 9999 | | | | | | | | | | |
| 856 | 0001101011 | IC43 filter | 0000 to 9999 | | | | | | | | | | |
| 857 | 1001101011 | IC44 filter | 0000 to 9999 | | | | | | | | | | |
| 858 | 0101101011 | IC45 filter | 0000 to 9999 | | | | | | | | | | |
| 859 | 1101101011 | IC46 filter | 0000 to 9999 | | | | | | | | | | |
| 860 | 0011101011 | IC47 filter | 0000 to 9999 | | | | | | | | | | |
| 861 | 1011101011 | IC48 filter | 0000 to 9999 | | | | | | | | | | |
| 862 | 0111101011 | IC49 filter | 0000 to 9999 | | | | | | | | | | |
| 863 | 1111101011 | IC50 filter | 0000 to 9999 | | | | | | | | | | |

*1 A: The condition of either OC or OS is displayed individually. B: The condition of the entire refrigerant system is displayed.

Other types of data

| No. | SW1 | Item | Display | | | | | | | | Unit (A, B) *1 | | Remarks | |
|-----|------------|-----------------------------------|---------|-----|-----|-----|-----|-----|----------------|-----|----------------|----|---------|----------------------|
| | | | LD1 | LD2 | LD3 | LD4 | LD5 | LD6 | LD7 | LD8 | OC | OS | | |
| 864 | 0000011011 | | | | | | | | | | | | | |
| 865 | 1000011011 | | | | | | | | | | | | | |
| 866 | 0100011011 | | | | | | | | | | | | | |
| 867 | 1100011011 | | | | | | | | | | | | | |
| 868 | 0010011011 | | | | | | | | | | | | | |
| 869 | 1010011011 | | | | | | | | | | | | | |
| 870 | 0110011011 | | | | | | | | | | | | | |
| 871 | 1110011011 | U-phase current effective value 1 | | | | | | | -99.9 to 999.9 | | | A | A | The unit is [A] |
| 872 | 0001011011 | W-phase current effective value 1 | | | | | | | -99.9 to 999.9 | | | A | A | |
| 873 | 1001011011 | Power factor phase angle 1 | | | | | | | -99.9 to 999.9 | | | A | A | The unit is [deg] |
| 874 | 0101011011 | | | | | | | | | | | | | |
| 875 | 1101011011 | | | | | | | | | | | | | |
| 876 | 0011011011 | | | | | | | | | | | | | |
| 877 | 1011011011 | | | | | | | | | | | | | |
| 878 | 0111011011 | | | | | | | | | | | | | |
| 879 | 1111011011 | | | | | | | | | | | | | |
| 880 | 0000111011 | Control board Reset counter | | | | | | | 0 to 254 | | | A | A | The unit is [time] |
| 881 | 1000111011 | INV board Reset counter | | | | | | | 0 to 254 | | | A | A | |
| 882 | 0100111011 | | | | | | | | | | | | | |
| 883 | 1100111011 | | | | | | | | | | | | | |
| 884 | 0010111011 | Fan board Reset counter | | | | | | | 0 to 254 | | | A | A | The unit is [time] |
| 885 | 1010111011 | | | | | | | | | | | | | |
| 886 | 0110111011 | | | | | | | | | | | | | |

*1 A: The condition of either OC or OS is displayed individually. B: The condition of the entire refrigerant system is displayed.

[X LED monitor display on the outdoor unit board]

Other types of data

| No. | SW1 | Item | Display | | | | | | | | Unit (A, B) *1 | | Remarks | |
|------|------------|------|---------|-----|-----|-----|-----|-----|-----|-----|-------------------|----|---------|--|
| | | | LD1 | LD2 | LD3 | LD4 | LD5 | LD6 | LD7 | LD8 | OC | OS | | |
| 887 | 1110111011 | | | | | | | | | | | | | |
| 888 | 0001111011 | | | | | | | | | | | | | |
| 889 | 1001111011 | | | | | | | | | | | | | |
| 890 | 0101111011 | | | | | | | | | | | | | |
| 891 | 1101111011 | | | | | | | | | | | | | |
| 892 | 0011111011 | | | | | | | | | | | | | |
| 893 | 1011111011 | | | | | | | | | | | | | |
| 894 | 0111111011 | | | | | | | | | | | | | |
| 895 | 1111111011 | | | | | | | | | | | | | |
| 896 | 0000000111 | | | | | | | | | | | | | |
| 897 | 1000000111 | | | | | | | | | | | | | |
| 898 | 0100000111 | | | | | | | | | | | | | |
| 899 | 1100000111 | | | | | | | | | | | | | |
| 900 | 0010000111 | | | | | | | | | | | | | |
| 901 | 1010000111 | | | | | | | | | | | | | |
| 902 | 0110000111 | | | | | | | | | | | | | |
| 903 | 1110000111 | | | | | | | | | | | | | |
| 904 | 0001000111 | | | | | | | | | | | | | |
| 905 | 1001000111 | | | | | | | | | | | | | |
| 906 | 0101000111 | | | | | | | | | | | | | |
| 907 | 1101000111 | | | | | | | | | | | | | |
| 1020 | 0011111111 | | | | | | | | | | | | | |
| 1021 | 1011111111 | | | | | | | | | | | | | |
| 1022 | 0111111111 | | | | | | | | | | | | | |
| 1023 | 1111111111 | | | | | | | | | | | | | |

*1 A: The condition of either OC or OS is displayed individually. B: The condition of the entire refrigerant system is displayed.

Service Handbook

Model

PUHY-P200, P250, P300, P350YHA

PUHY-P400, P450YHA

PUHY-P500, P550, P600, P650YSHA

PUHY-P700, P750, P800, P850, P900YSHA

PUHY-P950, P1000, P1050, P1100, P1150, P1200, P1250YSHA

 **MITSUBISHI ELECTRIC CORPORATION**

<http://Global.MitsubishiElectric.com>