

PLA SERIES



A complete line-up including deluxe units that offer added energy savings. The incorporation of "3D total flow" and the "3D i-see Sensor" enhances airflow distribution control, achieving an enhanced level of comfort throughout the room. The synergy of higher energy efficiency and more comfortable room environment results in the utmost user satisfaction.

Deluxe 4-way Cassette Line-up

For users seeking even further energy savings, Mitsubishi Electric now offers deluxe units (PLA-ZM) to complete the line-up of models in this series, from 35-140. Compared to the standard models (PLA-M), deluxe models provide additional energy savings, contributing to a significant reduction in electricity costs.

Line-up

Series	Model	35	50	60	71	100	125	140
R32	Deluxe 4-way Cassette (PLA-ZM)	●	●	●	●	●	●	●
R32	Standard 4-way Cassette (PLA-M)	●	●	●	●	●	●	●

Indoor/Outdoor Unit Combinations

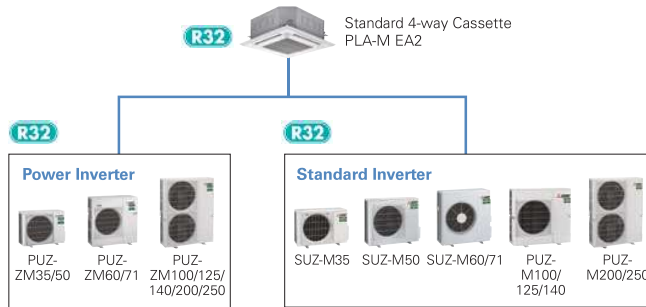
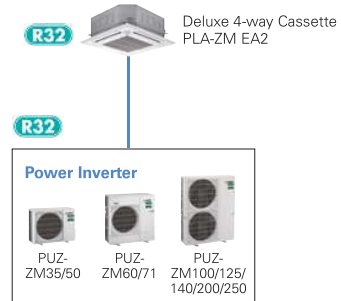

Industry-leading energy efficiency

Introduction of R32 refrigerant realises improved cooling efficiency. Rating of more than 7.0 achieved for all capacity range. Introduction of R32 refrigerant reduces energy consumption and realises energy savings.

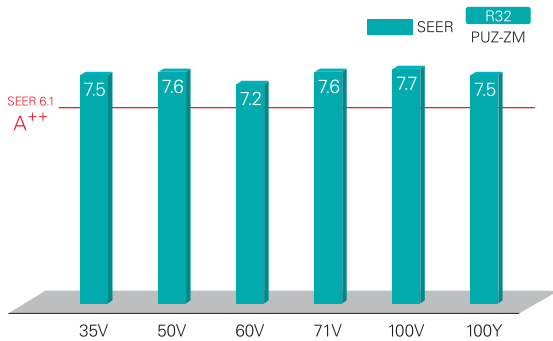

Horizontal Airflow

The new airflow control removes that uncomfortable drafty feeling with the introduction of a horizontal airflow that spreads across the ceiling. The ideal airflow for offices and restaurants.



[Horizontal airflow]
Model name: PLA-ZM140EA2
Ceiling height: 3.2m
Mode: Cooling

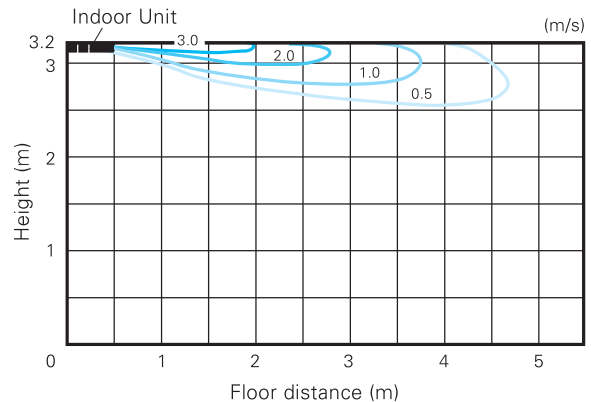

Automatic Grille Lowering Function (PLP-6EAJ, PLP-6EAJE)*

An automatic grille lowering function is available for easy filter maintenance. Special wired and wireless remote controllers can be used to lower the intake grille for maintenance.

*Auto elevation panel(PLP-6EAJ,PLP-6EAJE) cannot be used with Plasma Quad Connect(PAC-SK51FFE) and Insulation kit (PAC-SK36HK-E).



Grille Elevation Remote Controller
(comes with the automatic elevation panel)



Wired Remote Controller



Wireless Remote Controller



Easy Installation

Electrical box wiring

After reviewing the power supply terminal position in the electrical box, the structure was redesigned to improve connectivity. This has made previously complex wiring work easier.

■ Previous model (B Series)



■ New model (E Series)



Increased space for plumbing work

The top and bottom positions of the liquid and gas pipes have been reversed to allow the gas pipe work, which requires more effort, to be completed first. Further, through structural innovations related to the space around the pipes, the area where the spanner can be moved has been increased, thus improving liquid pipe work and enabling it to be completed smoothly.

■ Previous model (B Series)

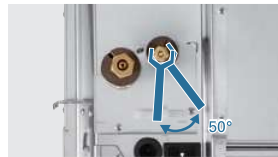

■ New model (E Series)



Temporary hanging hook

The structure of the panel has been revised and is now equipped with a temporary hanging hook. This has improved work efficiency during panel installation.



No need to remove screws

Installation is possible without removing the screws for the corner panel and the control box, simply loosen them. This lowers the risk of losing screws.

■ Corner panel



■ Control box cover



Lightweight decorative panel

After reviewing the structure and materials, weight has been reduced approximately 20% compared to the previous model, reducing the burden of installation.



3D i-see Sensor for S & P SERIES

Detects number of people

3D i-see Sensor detects the number of people in the room and sets the air-conditioning power accordingly. This makes automatic power-saving operation possible in places where the number of people entering and exiting is large. Additionally, when the area is continuously unoccupied, the system switches to a more enhanced power-saving mode. Depending on the setting, it will save additional capacity or stop operation altogether.

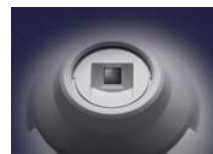

Detects number of people



Detects people's position

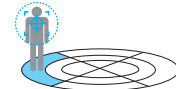

Detects people's position

Once the position of a person is detected, the duct angle of the vane is automatically adjusted in that direction. Each vane can be independently set to "block wind" or "not block wind" according to taste.

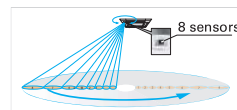

Detects position and number of people

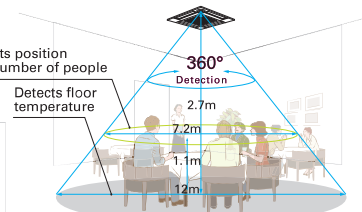

Detects floor temperature

Floor surface *In case of a 2.7m ceiling

Detects number of people (3D i-see Sensor)

Room occupancy energy-saving mode

The 3D i-see Sensor detects the number of people in the room. It then calculates the occupancy rate based on the maximum number of people in the room up to that point in time in order to save air-conditioning power. When the occupancy rate is approximately 30%, air-conditioning power equivalent to 1°C during both cooling and heating operation is saved. The temperature is controlled according to the number of people.

No occupancy energy-saving mode

When 3D i-see Sensor detects that no one is in the room, the system is switched to a pre-set power-saving mode. If the room remains unoccupied for more than 60min, air-conditioning power equivalent to 2°C during both cooling and heating operation is saved. This contributes to preventing waste in terms of heating and cooling.

No occupancy Auto-OFF mode*

When the room remains unoccupied for a pre-set period of time, the air conditioner turns off automatically, thereby providing even greater power savings. The time until operation is stopped can be set in intervals of 10min, ranging from 60 to 180 min.

* When MA Remote Controller is used to control multiple refrigerant systems, "No occupancy Auto-OFF mode" cannot be used.

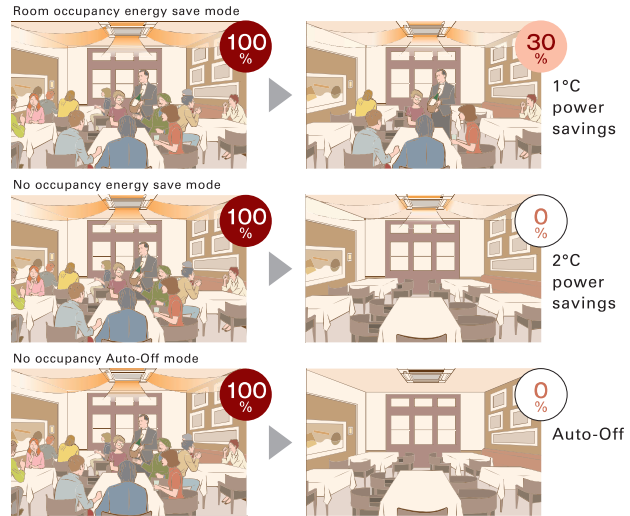

*PAR-41MAA is required for each setting

Detects people's position (3D i-see Sensor)

Direct/Indirect settings*

Some people do not like the feel of wind, some want to be warm from head to toe. People's likes and dislikes vary. With the 3D i-see Sensor, it is possible to choose to block or not block to the wind for each vane.

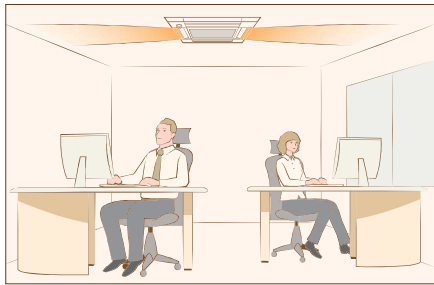

*PAR-41MAA or PAR-SL101A-E is required for each setting.

Seasonal airflow*

<When cooling>

Saves energy while keeping a comfortable effective temperature by automatically switching between ventilation and cooling. When a pre-set temperature is reached, the air conditioning unit switches to swing fan operation to maintain the effective temperature. This clever function contributes to keeping a comfortable coolness.

<When heating>

The air conditioning unit automatically switches between circulator and heating. Wasted heat that accumulates near the ceiling is reused via circulation. When a pre-set temperature is reached the air conditioner switches from heating to circulator and blows air in the horizontal direction. It pushes down the warm air that has gathered near the ceiling to people's height, thereby providing smart heating.

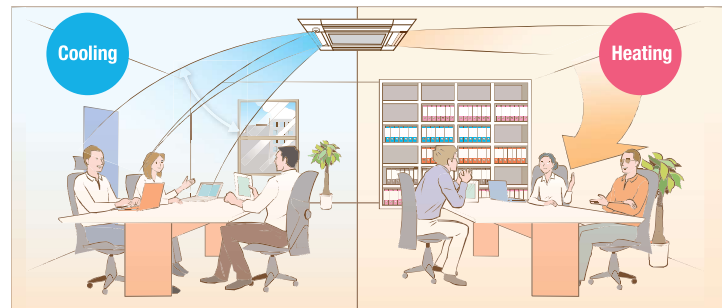

*PAR-41MAA is required for each setting.

3D Total Flow*

3D Total Flow is an innovative function. Our original 3D i-see sensor detects the temperature of the floor, and then the newly installed 3D Total Flow unit automatically controls the airflow in the left/right directions in a smart manner.

*3D Total Flow unit(PLP-U160ELR-E) cannot be used with Plasma Quad Connect(PAC-SK51FFE), Insulation kit(PAC-SK36HK-E), Shutter Plate(PAC-SJ37SP-E), Multi functional casement(PAC-SJ41TM-E) and High-efficiency filter element(PAC-SH59KFE)

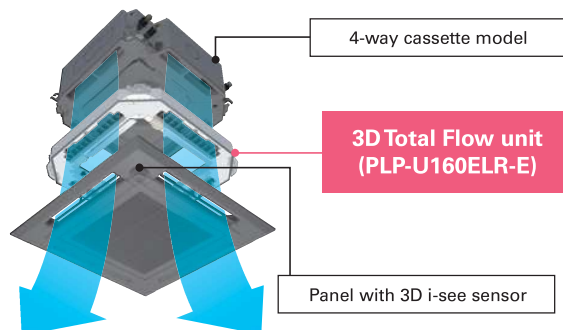

Horizontal louver (3D Total Flow)

In addition to the ability of conventional models to control airflow in the vertical direction, the adoption of a horizontal louver unit allows each outlet to blow air over a horizontal angle of 90 degrees. The combination of four outlets delivers 360° airflow control around the entire circumference. This now makes it possible to blow air in diagonal directions which eliminates temperature irregularities.



louvers can provide horizontal airflow control.



Swinging

Since airflow can be controlled in the horizontal and vertical directions, you can efficiently make the entire room comfortable.

Horizontal, vertical, and diagonal airflow delivered to every corner

The combination of the vertical vanes with the horizontal louver unit makes it possible to direct airflow in any direction. This quickly makes the entire room comfortable, even when diagonal airflow is necessary.

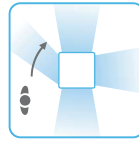
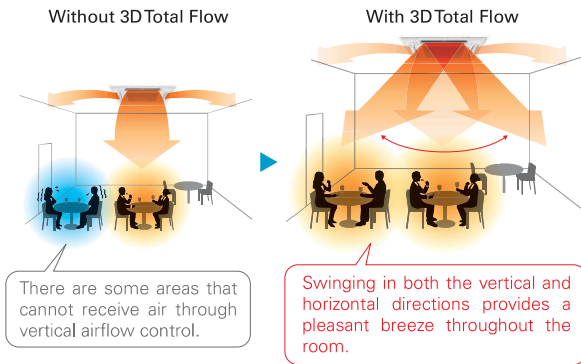

Indirect mode

When set to "Indirect" mode, the system detects the position of a person and maintains comfort while diverting airflow away from them.

Prevents direct airflow and keeps you comfortable

This function prevents people from being directly exposed to airflow while still ensuring comfort. The "Indirect" mode of 3D Total Flow keeps the downward airflow while avoiding direct blow to people, delivering a pleasant warmth.

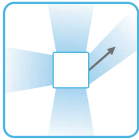
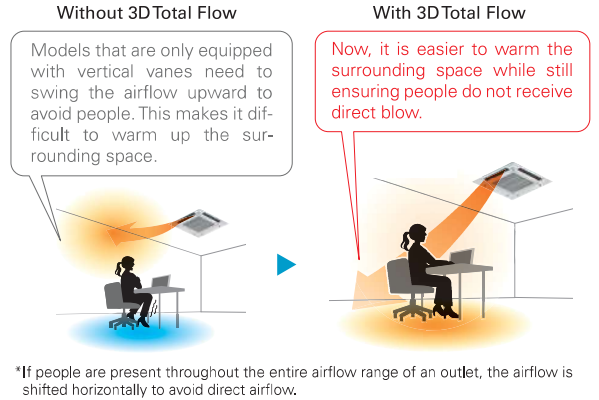

Targeting

The system can detect spaces with uneven temperatures and target them by sending air even if they are in a diagonal direction.

Detects and targets areas with uneven temperatures

3D i-see sensor detects areas with uneven temperatures, even if they are caused by the installation orientation of the air conditioner or the influence of strong sunlight. Efficient air conditioning is possible thanks to the ability to send focused airflow to such areas, even those in a diagonal position.

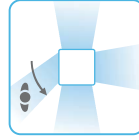
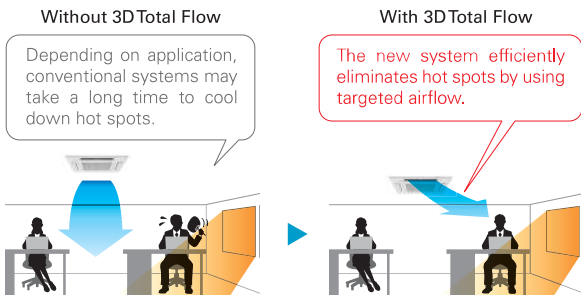

Direct mode

When set to "Direct" mode, the system detects the position and diverts airflow towards wherever they are located.

Delivers airflow even in diagonal directions

You can freely turn on "Direct" mode depending on personal preference. This allows for air conditioning in diagonal directions which was difficult for models that could only swing the airflow up and down. This feature is perfect for when you come back home on a hot day.

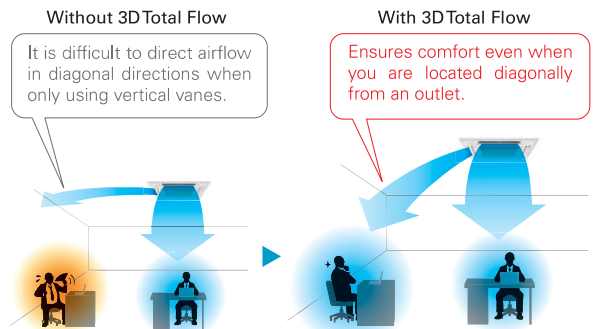

Connectable to Plasma Quad Connect*

The optional Plasma Quad Connect PAC-SK51FTE can be installed on the indoor units.

*Plasma Quad Connect(PAC-SK51FTE) cannot be used with PLP-U160ELR-E(3D Total Flow unit), Insulation kit (PAC-SK36HK-E), Auto elevation panel(PLP-6EAJ, PLP-6EAJE), Multi-functional casement(PAC-SJ41TM-E) and High-efficiency filter element(PAC-SH59KF-E).

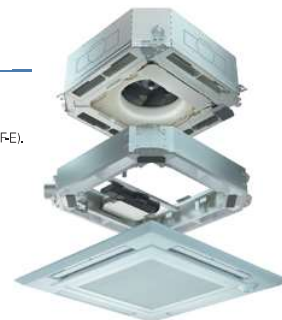

SERIES SELECTION

Power Inverter Series



Indoor Unit

R32
R410A



Panel PLA-ZM35/50/60/71/100/125/140EA2

Panel	With Signal Receiver	With 3D i-see Sensor	With Wireless Remote Controller	With Auto Elevation
PLP-6EA(B)				
PLP-6EAL	✓			
PLP-6EAE		✓		
PLP-6EALE	✓	✓		
PLP-6EAJ*	✓			✓
PLP-6EAJE*	✓	✓		✓
PLP-6EALM2	✓		✓	
PLP-6EALME2	✓	✓	✓	

*Auto elevation panel(PLP-6EAJ,PLP-6EAJE) cannot be used with Plasma Quad Connect(PAC-SK51FT-E) and Insulation kit (PAC-SK36HK-E).

Outdoor Unit

R32

For Single



PUZ-ZM35/50 PUZ-ZM60/71 PUZ-ZM100/125/140

R32

For Multi
(Twin/Triple/Quadruple)



PUZ-ZM71 PUZ-ZM100/125/140/200/250

3D Total Flow Unit

PLP-U160ELR-E (optional)



Black Panel



Remote Controller



PLP-6EAB (optional)

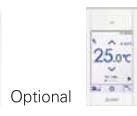

Optional



Optional



Optional

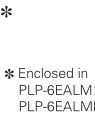

Optional

* Enclosed in PLP-6EALM2/PLP-6EALME2

PLA-ZM EA2 Indoor Unit Combinations Indoor unit combinations shown below are possible.

Indoor Unit Combination	Outdoor Unit Capacity																			
	For Single									For Twin						For Triple			For Quadruple	
	35	50	60	71	100	125	140	200	250	71	100	125	140	200	250	140	200	250	200	250
Power Inverter (PUZ-ZM)	35x1	50x1	60x1	71x1	100x1	125x1	140x1	-	-	35x2	50x2	60x2	71x2	100x2	125x2	50x3	60x3	71x3	50x4	60x4
Distribution Pipe	-	-	-	-	-	-	-	-	-	MSDD-50TR2-E			MSDD-50WR2-E			MSDT-111R3-E			MSDF-1111R2-E	

SERIES SELECTION

Standard Inverter Series



Indoor Unit

R32
R410A



Panel PLA-M35/50/60/71/100/125/140EA2

Panel	With Signal Receiver	With 3D i-see Sensor	With Wireless Remote Controller	With Auto Elevation
PLP-6EA(B)				
PLP-6EAL	✓			
PLP-6EAE		✓		
PLP-6EALE	✓	✓		
PLP-6EAJ*	✓			✓
PLP-6EAJE*	✓	✓		✓
PLP-6EALM2	✓		✓	
PLP-6EALME2	✓	✓	✓	

*Auto elevation panel(PLP-6EAJ,PLP-6EAJE) cannot be used with Plasma Quad Connect(PAC-SK51FT-E) and Insulation kit (PAC-SK36HK-E).

Outdoor Unit

R32

For Single



SUZ-M35 SUZ-M50 SUZ-M60/71 PUZ-M100/125/140

R32

For Multi
(Twin/Triple/Quadruple)



PUZ-M100/125/140 PUZ-M200/250

3D Total Flow Unit

PLP-U160ELR-E* (optional)



Black Panel



Remote Controller



PLP-6EAB (optional)

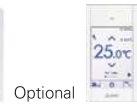

Optional



Optional



Optional

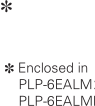

Optional

* Enclosed in PLP-6EALM2/PLP-6EALME2

PLA-M EA2 Indoor Unit Combinations Indoor unit combinations shown below are possible.

Indoor Unit Combination	Outdoor Unit Capacity																			
	For Single									For Twin						For Triple			For Quadruple	
	35	50	60	71	100	125	140	200	250	71	100	125	140	200	250	140	200	250	200	250
Standard Inverter (SUZ & PUZ-M)	35x1	50x1	60x1	71x1	100x1	125x1	140x1	-	-	50x2	60x2	71x2	100x2	125x2	50x3	60x3	71x3	50x4	60x4	
Distribution Pipe	-	-	-	-	-	-	-	-	-	MSDD-50TR2-E			MSDD-50WR2-E			MSDT-111R3-E			MSDF-1111R2-E	

PLA-M SERIES

POWER INVERTER



Type			Inverter Heat Pump									
Indoor Unit			PLA-M35EA2	PLA-M50EA2	PLA-M60EA2	PLA-M71EA2	PLA-M100EA2	PLA-M100EA2	PLA-M125EA2	PLA-M125EA2	PLA-M140EA2	PLA-M140EA2
Outdoor Unit			PuZ-ZM35VKa2	PuZ-ZM50VKa2	PuZ-ZM60VHA2	PuZ-ZM71VHA2	PuZ-ZM100VKa2	PuZ-ZM100YKa2	PuZ-ZM125VKa2	PuZ-ZM125YKa2	PuZ-ZM140VKa2	PuZ-ZM140YKa2
Refrigerant ¹⁾			R32									
Power Supply			Outdoor power supply									
Source			VKA · VHA:230/Single/50, YKA:400/Three/50									
Outdoor(V/Phase/Hz)												
Cooling	Capacity	Rated	kW	3.6	5.0	6.1	7.1	9.5	9.5	12.5	13.4	13.4
		Min-Max	kW	1.6 - 4.5	2.3 - 5.6	2.7 - 6.5	3.3 - 8.1	4.9 - 11.4	4.9 - 11.4	5.5 - 14.0	5.5 - 14.0	6.2 - 15.0
	Total Input	Rated	kW	0.751	1.175	1.523	1.716	2.209	2.209	3.396	3.396	3.746
	EER			4.79	4.25	4.00	4.14	4.30	4.30	3.68	3.68	3.58
	Design load		kW	3.6	5.0	6.1	7.1	9.5	9.5	-	-	-
	Annual electricity consumption ²⁾		kWh/a	172	234	301	336	437	448	-	-	-
Heating (Average Season)	SEER ⁴⁾			7.3	7.4	7.1	7.4	7.6	7.4	-	-	-
	Energy efficiency class			A+	A+	A+	A+	A+	A+	-	-	-
	Capacity	Rated	kW	4.1	6.0	7.0	8.0	11.2	11.2	14.0	14.0	16.0
		Min-Max	kW	1.6 - 5.2	2.5 - 7.3	2.8 - 8.2	3.5 - 10.2	4.5 - 14.0	4.5 - 14.0	5.0 - 16.0	5.0 - 16.0	5.7 - 18.0
	Total Input	Rated	kW	0.890	1.581	1.863	2.014	2.685	2.685	3.773	3.773	4.365
	COP			4.61	3.79	3.76	3.97	4.17	4.17	3.71	3.71	3.67
Design load		kW	2.5	3.8	4.4	4.7	7.8	7.8	-	-	-	
Declared Capacity	at reference design temperature	kW	2.5 (-10°C)	3.8 (-10°C)	4.4 (-10°C)	4.7 (-10°C)	7.8 (-10°C)	7.8 (-10°C)	-	-	-	
	at bivalent temperature	kW	2.5 (-10°C)	3.8 (-10°C)	4.4 (-10°C)	4.7 (-10°C)	7.8 (-10°C)	7.8 (-10°C)	-	-	-	
Back up heating capacity	at operation limit temperature	kW	2.1 (-11°C)	3.7 (-11°C)	2.8 (-20°C)	3.4 (-20°C)	5.8 (-20°C)	5.8 (-20°C)	-	-	-	
		kW	0.0	0.0	0.0	0.0	0.0	0.0	-	-	-	
Annual electricity consumption ²⁾		kWh/a	798	1187	1422	1429	2496	2497	-	-	-	
SCOP ⁴⁾			4.3	4.4	4.3	4.6	4.3	4.3	-	-	-	
Energy efficiency class			A+	A+	A+	A++	A+	A+	-	-	-	
Operating Current(Max)		A	13.2	13.2	19.2	19.3	20.5	8.5	27.2	9.7	30.7	
Indoor Unit	Input [cooling / Heating]	Rated	kW	0.03 / 0.03	0.03 / 0.03	0.03 / 0.03	0.04 / 0.04	0.07 / 0.07	0.07 / 0.07	0.10 / 0.10	0.10 / 0.10	
	Operating Current(Max)		A	0.20	0.22	0.24	0.27	0.46	0.46	0.66	0.66	
	Dimensions	H*W*D	mm	258-840-840			<40-950-950>			298-840-840		
	Weight		kg	19 <5>	19 <5>	21 <5>	21 <5>	24 <5>	24 <5>	26 <5>	26 <5>	
	Air Volume (Lo-Mid-Hi)		m³/min	11-13-15-16	12-14-16-18	12-14-16-18	14-17-19-21	19-23-26-29	19-23-26-29	21-25-29-31	21-25-29-31	
	Sound Level (Lo-Mid-Hi) (SPL)		dB(A)	26-28-29-31	27-29-31-32	27-29-31-32	28-30-32-34	31-34-37-40	31-34-37-40	33-37-41-44	33-37-41-44	
Sound Level (PWL)		dB(A)	51	54	54	56	61	61	65	65		
Outdoor Unit	Dimensions	H*W*D	mm	630-809-300	630-809-300	943-950-330(+25)	943-950-330(+25)	1338-1050-330(+40)	1338-1050-330(+40)	1338-1050-330(+40)	1338-1050-330(+40)	
	Weight		kg	46	46	67	67	105	111	105		
	Air Volume	Cooling	m³/min	45	45	55	55	110	110	120		
		Heating	m³/min	45	45	55	55	110	110	120		
	Sound Level (SPL)	Cooling	dB(A)	44	44	47	47	49	49	50		
		Heating	dB(A)	46	46	49	49	51	51	52		
Sound Level (PWL)	Cooling	dB(A)	65	65	67	67	69	69	70			
	Heating	dB(A)	65	65	67	67	69	69	70			
Operating Current(Max)		A	13	13	19	19	20	8	26.5	9		
Breaker Size		A	16	16	25	25	32	16	32	16		
Ext.Piping	Diameter ⁵⁾	Liquid/Gas	mm	6.35 / 12.7	6.35 / 12.7	9.52 / 15.88	9.52 / 15.88	9.52 / 15.88	9.52 / 15.88	9.52 / 15.88		
	Max.Length	Out-In	m	50	50	55	55	100	100	100		
	Max.Height	Out-In	m	30	30	30	30	30	30	30		
Guaranteed Operating Range (Outdoor)	Cooling ³⁾	°C	-15 ~ +46	-15 ~ +46	-15 ~ +46	-15 ~ +46	-15 ~ +46	-15 ~ +46	-15 ~ +46	-15 ~ +46		
	Heating	°C	-11 ~ +21	-11 ~ +21	-20 ~ +21	-20 ~ +21	-20 ~ +21	-20 ~ +21	-20 ~ +21	-20 ~ +21		

*1 Refrigerant leakage contributes to climate change. Refrigerant with lower global warming potential (GWP) would contribute less to global warming than a refrigerant with higher GWP, if leaked to the atmosphere. This appliance contains a refrigerant fluid with a GWP equal to 550. This means that if 1 kg of this refrigerant fluid would be leaked to the atmosphere, the impact on global warming would be 550 times higher than 1 kg of CO₂ over a period of 100 years. Never try to interfere with the refrigerant circuit yourself or disassemble the product yourself and always ask a professional. The GWP of R32 is 675 in the IPCC 4th Assessment Report.

*2 Energy consumption based on standard test results. Actual energy consumption will depend on how the appliance is used and where it is located.

*3 Optional air protection guide is required where ambient temperature is lower than -5°C.

*4 SEER and SCOP are based on 2009/125/EC Energy-related Products Directive and Regulation (EU) No206/2012.

*5 Joint pipe is required depending on installed refrigerant pipes, outdoor units and indoor units.