

Mr. SLIM

Air-Conditioners

PUZ-ZM•YKA Series

PUZ-M•YKA Series

INSTALLATION MANUAL

FOR INSTALLER

English

Contents

For safe and correct use, read this manual and the indoor unit installation manual thoroughly before installing the air-conditioner unit.

1. Safety precautions	1	7. Test run	14
2. Installation location	3	8. Special Functions	15
3. Installing the outdoor unit	7	9. System control (Fig. 9-1)	15
4. Installing the refrigerant piping	7	10. Specifications	16
5. Drainage piping work	11	11. Serial number	16
6. Electrical work	12		



Note: This symbol mark is for EU countries only.

This symbol mark is according to the directive 2012/19/EU Article 14 Information for users and Annex IX.

Your MITSUBISHI ELECTRIC product is designed and manufactured with high quality materials and components which can be recycled and reused.

This symbol means that electrical and electronic equipment, at their end-of-life, should be disposed of separately from your household waste.

Please, dispose of this equipment at your local community waste collection/recycling centre.

In the European Union there are separate collection systems for used electrical and electronic product.

Please, help us to conserve the environment we live in!

⚠ Caution:

- Do not vent R32 into the atmosphere.

1. Safety precautions

en

- ▶ Before installing the unit, make sure you read all the "Safety precautions".
- ▶ Please report to or take consent by the supply authority before connection to the system.
- ▶ ZM200/250, M200/250

"This equipment complies with IEC 61000-3-12 provided that the short-circuit power S_{sc} is greater than or equal to $S_{sc} (*1)$ at the interface point between the user's supply and the public system. It is the responsibility of the installer or user of the equipment to ensure, by consultation with the distribution network operator if necessary, that the equipment is connected only to a supply with a short-circuit power S_{sc} greater than or equal to $S_{sc} (*1)$ "

$S_{sc} (*1)$

Model	S_{sc} (MVA)
ZM200, M200	1.35
ZM250, M250	1.35

⚠ Warning:

Describes precautions that must be observed to prevent danger of injury or death to the user.

⚠ Caution:

Describes precautions that must be observed to prevent damage to the unit.

After installation work has been completed, explain the "Safety Precautions," use, and maintenance of the unit to the customer according to the information in the Operation Manual and perform the test run to ensure normal operation. Both the Installation Manual and Operation Manual must be given to the user for keeping. These manuals must be passed on to subsequent users.

⚡ : Indicates a part which must be grounded.

⚠ Warning:

Carefully read the labels affixed to the main unit.

⊙ : Indicates warnings and cautions when using R32 refrigerant.

MEANINGS OF SYMBOLS DISPLAYED ON INDOOR UNIT AND/OR OUTDOOR UNIT

	WARNING (Risk of fire)	This mark is for R32 refrigerant only. Refrigerant type is written on nameplate of outdoor unit. In case that refrigerant type is R32, this unit uses a flammable refrigerant. If refrigerant leaks and comes in contact with fire or heating part, it will create harmful gas and there is risk of fire.
		Read the OPERATION MANUAL carefully before operation.
		Service personnel are required to carefully read the OPERATION MANUAL and INSTALLATION MANUAL before operation.
		Further information is available in the OPERATION MANUAL, INSTALLATION MANUAL, and the like.

⚠ Warning:

- The unit must not be installed by the user. Ask a dealer or an authorized technician to install and repair the unit. If the unit is installed incorrectly, water leakage, electric shock, or fire may result.
- For installation and relocation work, follow the instructions in the Installation Manual and use tools and pipe components specifically made for use with R32 refrigerant. If pipe components not designed for R32 refrigerant are used and the unit is not installed correctly, the pipes may burst and cause damage or injuries. In addition, water leakage, electric shock, or fire may result.
- The unit must be installed according to the instructions in order to minimize the risk of damage from earthquakes, typhoons, or strong winds. An incorrectly installed unit may fall down and cause damage or injuries.
- The unit must be securely installed on a structure that can sustain its weight. If the unit is mounted on an unstable structure, it may fall down and cause damage or injuries.
- If the air conditioner is installed in a small room, measures must be taken to prevent the refrigerant concentration in the room from exceeding the safety limit in the event of refrigerant leakage. Consult a dealer regarding the appropriate measures to prevent the allowable concentration from being exceeded. Should the refrigerant leak and cause the concentration limit to be exceeded, hazards due to lack of oxygen in the room may result.
- Ventilate the room if refrigerant leaks during operation. If refrigerant comes into contact with a flame, poisonous gases will be released.
- All electric work must be performed by a qualified technician according to local regulations and the instructions given in this manual. The units must be powered by dedicated power lines and the correct voltage and circuit breakers must be used. Power lines with insufficient capacity or incorrect electrical work may result in electric shock or fire.
- Use C1220 copper phosphorus, for copper and copper alloy seamless pipes, to connect the refrigerant pipes. If the pipes are not connected correctly, the unit will not be properly grounded and electric shock may result.
- This appliance is intended to be used by expert or trained users in shops, in light industry and on farms, or for commercial use by lay persons.
- Use only specified cables for wiring. The wiring connections must be made securely with no tension applied on the terminal connections. Also, never splice the cables for wiring (unless otherwise indicated in this document). Failure to observe these instructions may result in overheating or a fire.
- If the supply cord is damaged, it must be replaced by the manufacturer, its service agent or similarly qualified persons in order to avoid hazard.
- The appliance shall be installed in accordance with national wiring regulations.
- The terminal block cover panel of the outdoor unit must be firmly attached. If the cover panel is mounted incorrectly and dust and moisture enter the unit, electric shock or fire may result.
- When installing or relocating, or servicing the air conditioner, use only the specified refrigerant (R32) to charge the refrigerant lines. Do not mix it with any other refrigerant and do not allow air to remain in the lines. If air is mixed with the refrigerant, then it can be the cause of abnormal high pressure in the refrigerant line, and may result in an explosion and other hazards.
The use of any refrigerant other than that specified for the system will cause mechanical failure or system malfunction or unit breakdown. In the worst case, this could lead to a serious impediment to securing product safety.
- Use only accessories authorized by Mitsubishi Electric and ask a dealer or an authorized technician to install them. If accessories are incorrectly installed, water leakage, electric shock, or fire may result.
- Do not alter the unit. It may cause fire, electric shock, injury or water leakage.
- The user should never attempt to repair the unit or transfer it to another location. If the unit is installed incorrectly, water leakage, electric shock, or fire may result. If the air conditioner must be repaired or moved, ask a dealer or an authorized technician.

1. Safety precautions

- After installation has been completed, check for refrigerant leaks. If refrigerant leaks into the room and comes into contact with the flame of a heater or portable cooking range, poisonous gases will be released.
- Do not use means to accelerate the defrosting process or to clean, other than those recommended by the manufacturer.
- The appliance shall be stored in a room without continuously operating ignition sources (for example: open flames, an operating gas appliance or an operating electric heater).
- Do not pierce or burn.
- Be aware that refrigerants may not contain an odour.
- ⊙ Pipe-work shall be protected from physical damage.
- The installation of pipe-work shall be kept to a minimum.
- Compliance with national gas regulations shall be observed.
- Keep any required ventilation openings clear of obstruction.
- ⊙ Do not use low temperature solder alloy in case of brazing the refrigerant pipes.
- ⊙ When performing brazing work, be sure to ventilate the room sufficiently. Make sure that there are no hazardous or flammable materials nearby. When performing the work in a closed room, small room, or similar location, make sure that there are no refrigerant leaks before performing the work. If refrigerant leaks and accumulates, it may ignite or poisonous gases may be released.
- ⊙ The appliance shall be stored in a well-ventilated area where the room size corresponds to the room area as specified for operation.
- ⊙ Keep gas-burning appliances, electric heaters, and other fire sources (ignition sources) away from the location where installation, repair, and other air conditioner work will be performed. If refrigerant comes into contact with a flame, poisonous gases will be released.
- ⊙ Do not smoke during work and transportation.

1.1. Before installation

⚠ Caution:

- Do not use the unit in an unusual environment. If the air conditioner is installed in areas exposed to steam, volatile oil (including machine oil), or sulfuric gas, areas exposed to high salt content such as the seaside, or areas where the unit will be covered by snow, the performance can be significantly reduced and the internal parts can be damaged.
- Do not install the unit where combustible gases may leak, be produced, flow, or accumulate. If combustible gas accumulates around the unit, fire or explosion may result.
- The outdoor unit produces condensation during the heating operation. Make sure to provide drainage around the outdoor unit if such condensation is likely to cause damage.
- When installing the unit in a hospital or communications office, be prepared for noise and electronic interference. Inverters, home appliances, high-frequency medical equipment, and radio communications equipment can cause the air conditioner to malfunction or breakdown. The air conditioner may also affect medical equipment, disturbing medical care, and communications equipment, harming the screen display quality.

1.2. Before installation (relocation)

⚠ Caution:

- Be extremely careful when transporting or installing the units. Two or more persons are needed to handle the unit, as it weighs 20 kg or more. Do not grasp the packaging bands. Wear protective gloves to remove the unit from the packaging and to move it, as you can injure your hands on the fins or the edge of other parts.
- Be sure to safely dispose of the packaging materials. Packaging materials, such as nails and other metal or wooden parts may cause stabs or other injuries.
- The base and attachments of the outdoor unit must be periodically checked for looseness, cracks or other damage. If such defects are left uncorrected, the unit may fall down and cause damage or injuries.
- Do not clean the air conditioner unit with water. Electric shock may result.
- Tighten all flare nuts to specification using a torque wrench. If tightened too much, the flare nut can break after an extended period and refrigerant can leak out.

1.3. Before electric work

⚠ Caution:

- Be sure to install circuit breakers. If not installed, electric shock may result.
- For the power lines, use standard cables of sufficient capacity. Otherwise, a short circuit, overheating, or fire may result.
- When installing the power lines, do not apply tension to the cables. If the connections are loosened, the cables can snap or break and overheating or fire may result.
- Be sure to ground the unit. Do not connect the ground wire to gas or water pipes, lightning rods, or telephone grounding lines. If the unit is not properly grounded, electric shock may result.
- Use circuit breakers (ground fault interrupter, isolating switch (+B fuse), and molded case circuit breaker) with the specified capacity. If the circuit breaker capacity is larger than the specified capacity, breakdown or fire may result.

1.4. Before starting the test run

⚠ Caution:

- Turn on the main power switch more than 12 hours before starting operation. Starting operation just after turning on the power switch can severely damage the internal parts. Keep the main power switch turned on during the operation season.
- Before starting operation, check that all panels, guards and other protective parts are correctly installed. Rotating, hot, or high voltage parts can cause injuries.
- Do not touch any switch with wet hands. Electric shock may result.
- Do not touch the refrigerant pipes with bare hands during operation. The refrigerant pipes are hot or cold depending on the condition of the flowing refrigerant. If you touch the pipes, burns or frostbite may result.
- After stopping operation, be sure to wait at least five minutes before turning off the main power switch. Otherwise, water leakage or breakdown may result.

1.5. Using R32 refrigerant air conditioners

⚠ Caution:

- Use C1220 copper phosphorus, for copper and copper alloy seamless pipes, to connect the refrigerant pipes. Make sure the insides of the pipes are clean and do not contain any harmful contaminants such as sulfuric compounds, oxidants, debris, or dust. Use pipes with the specified thickness. (Refer to 4.1.) Note the following if reusing existing pipes that carried R22 refrigerant.
 - Replace the existing flare nuts and flare the flared sections again.
 - Do not use thin pipes. (Refer to 4.1.)
- Store the pipes to be used during installation indoors and keep both ends of the pipes sealed until just before brazing. (Leave elbow joints, etc. in their packaging.) If dust, debris, or moisture enters the refrigerant lines, oil deterioration or compressor breakdown may result.
- Use ester oil, ether oil, alkylbenzene oil (small amount) as the refrigeration oil applied to the flared sections. If mineral oil is mixed in the refrigeration oil, oil deterioration may result.
- Servicing shall be performed only as recommended by the manufacturer.
- Do not use refrigerant other than R32 refrigerant. If another refrigerant is used, the chlorine will cause the oil to deteriorate.
- Use the following tools specifically designed for use with R32 refrigerant. The following tools are necessary to use R32 refrigerant. Contact your nearest dealer for any questions.

Tools (for R32)	
Gauge manifold	Flare tool
Charge hose	Size adjustment gauge
Gas leak detector	Vacuum pump adapter
Torque wrench	Electronic refrigerant charging scale

- Be sure to use the correct tools. If dust, debris, or moisture enters the refrigerant lines, refrigeration oil deterioration may result.

1. Safety precautions

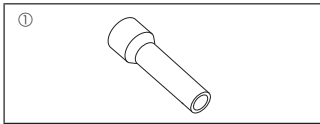

Fig. 1-1

1.6. Accessories of outdoor unit (Fig. 1-1) (ZM200/250, M200/250)

The parts show in the left are the accessories of this unit, which are affixed to the inside of the service panel.

① Joint Pipe accessoryx1

- (1) Put flare nut which is removed from the Ball Valve on the Joint Pipe accessory and carry out flare work.
- (2) The Joint Pipe accessory and the pipe which is prepared on site must be brazed in non-oxidation status.
- (3) After the pipes are brazed, connect the Joint Pipe accessory to the Ball Valve which locates within the unit by flare connection.

* Never connect the Joint Pipe accessory to the Ball Valve before brazing. Some parts may be burnt and it may cause refrigerant leakage.

2. Installation location

en

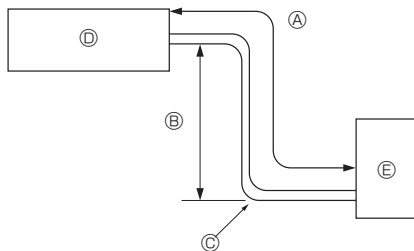

Fig. 2-1

2.1. Refrigerant pipe (Fig. 2-1)

► Check that the difference between the heights of the indoor and outdoor units, the length of refrigerant pipe, and the number of bends in the pipe are within the limits shown below.

Models	Ⓐ Pipe length (one way)	Ⓑ Height difference	Ⓒ Number of bends (one way)
ZM200/250	Max. 100 m	Max. 30 m	Max. 15
M200/250	Max. 70 m	Max. 30 m	Max. 15

- Height difference limitations are binding regardless of which unit, indoor or outdoor, is positioned higher.

Ⓓ Indoor unit
Ⓔ Outdoor unit

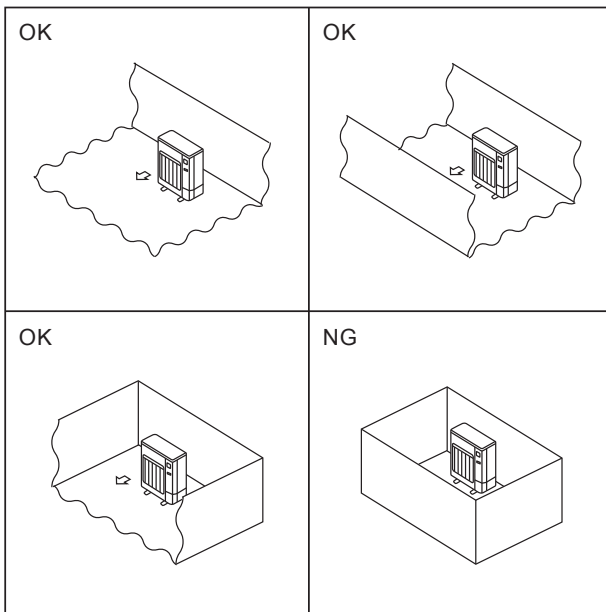

Fig. 2-2

2.2. Choosing the outdoor unit installation location

Ⓢ R32 is heavier than air—as well as other refrigerants—so tends to accumulate at the base (in the vicinity of the floor). If R32 accumulates around base, it may reach a flammable concentration in case room is small. To avoid ignition, maintaining a safe work environment is required by ensuring appropriate ventilation. If a refrigerant leak is confirmed in a room or an area where there is insufficient ventilation, refrain from using of flames until the work environment can be improved by ensuring appropriate ventilation.

- Avoid locations exposed to direct sunlight or other sources of heat.
- Select a location from which noise emitted by the unit will not inconvenience neighbors.
- Select a location permitting easy wiring and pipe access to the power source and indoor unit.
- Avoid locations where combustible gases may leak, be produced, flow, or accumulate.
- Note that water may drain from the unit during operation.
- Select a level location that can bear the weight and vibration of the unit.
- Avoid locations where the unit can be covered by snow. In areas where heavy snow fall is anticipated, special precautions such as raising the installation location or installing a hood on the air intake must be taken to prevent the snow from blocking the air intake or blowing directly against it. This can reduce the airflow and a malfunction may result.
- Avoid locations exposed to oil, steam, or sulfuric gas.
- Use the transportation handles of the outdoor unit to transport the unit. If the unit is carried from the bottom, hands or fingers may be pinched.
- Refrigerant pipes connection shall be accessible for maintenance purposes.

Ⓢ Install outdoor units in a place where at least one of the four sides is open, and in a sufficiently large space without depressions. (Fig. 2-2)

2. Installation location

- ZM200, 250
- M200, 250

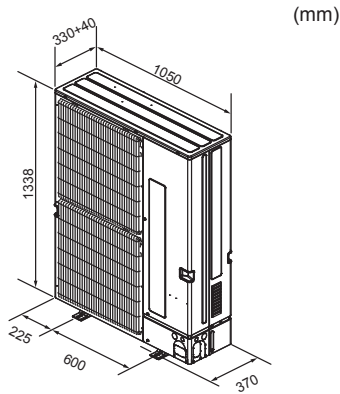

Fig. 2-3

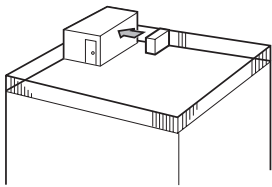

Fig. 2-4

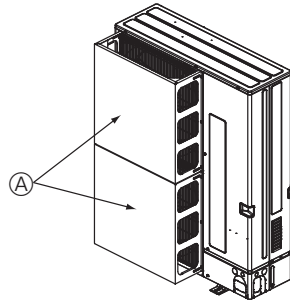

Fig. 2-5

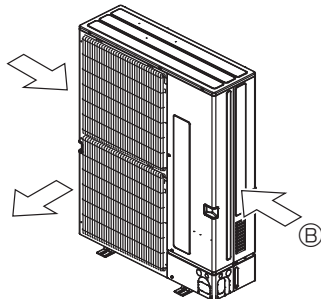

Fig. 2-6

2.3. Outline dimensions (Outdoor unit) (Fig. 2-3)

2.4. Ventilation and service space

2.4.1. Windy location installation

When installing the outdoor unit on a rooftop or other location unprotected from the wind, situate the air outlet of the unit so that it is not directly exposed to strong winds. Strong wind entering the air outlet may impede the normal airflow and a malfunction may result.

The following shows three examples of precautions against strong winds.

- ① Face the air outlet towards the nearest available wall about 50 cm away from the wall. (Fig. 2-4)
- ② Install an optional air guide if the unit is installed in a location where strong winds from a typhoon, etc. may directly enter the air outlet. (Fig. 2-5)
 - Ⓐ Air outlet guide
- ③ Position the unit so that the air outlet blows perpendicularly to the seasonal wind direction, if possible. (Fig. 2-6)
 - Ⓑ Wind direction

2.4.2. When installing a single outdoor unit (Refer to the last page)

Minimum dimensions are as follows, except for Max., meaning Maximum dimensions, indicated.

Refer to the figures for each case.

- ① Obstacles at rear only (Fig. 2-7)
- ② Obstacles at rear and above only (Fig. 2-8)
- ③ Obstacles at rear and sides only (Fig. 2-9)
- ④ Obstacles at front only (Fig. 2-10)
 - * When using an optional air outlet guide, the clearance is 500 mm or more.
- ⑤ Obstacles at front and rear only (Fig. 2-11)
 - * When using an optional air outlet guide, the clearance is 500 mm or more.
- ⑥ Obstacles at rear, sides, and above only (Fig. 2-12)
 - * Do not install the optional air outlet guides for upward airflow.

2.4.3. When installing multiple outdoor units (Refer to the last page)

Leave 50 mm for ZM200, 250/M200, 250 space or more between the units.

- ① Obstacles at rear only (Fig. 2-13)
- ② Obstacles at rear and above only (Fig. 2-14)
 - * No more than 3 units must be installed side by side. In addition, leave space as shown.
 - * Do not install the optional air outlet guides for upward airflow.
- ③ Obstacles at front only (Fig. 2-15)
 - * When using an optional air outlet guide, the clearance is 1000 mm or more.
- ④ Obstacles at front and rear only (Fig. 2-16)
 - * When using an optional air outlet guide, the clearance is 1000 mm or more.
- ⑤ Single parallel unit arrangement (Fig. 2-17)
 - * When using an optional air outlet guide installed for upward airflow, the clearance is 1000 mm or more.
- ⑥ Multiple parallel unit arrangement (Fig. 2-18)
 - * When using an optional air outlet guide installed for upward airflow, the clearance is 1500 mm or more.
- ⑦ Stacked unit arrangement (Fig. 2-19)
 - * The units can be stacked up to two units high.
 - * No more than 2 stacked units must be installed side by side. In addition, leave space as shown.

2. Installation location

©2.5. Minimum installation area

If you unavoidably install a unit in a space where all four sides are blocked or there are depressions, confirm that one of these situations (A, B or C) is satisfied.

Note: These countermeasures are for keeping safety not for specification guarantee.

A) Secure sufficient installation space (minimum installation area A_{min}).

Install in a space with an installation area of A_{min} or more, corresponding to refrigerant quantity M (factory-charged refrigerant + locally added refrigerant).

M [kg]	A_{min} [m ²]
1.0	12
1.5	17
2.0	23
2.5	28
3.0	34
3.5	39
4.0	45
4.5	50
5.0	56
5.5	62
6.0	67
6.5	73
7.0	78
7.5	84
8.0	89
8.5	95
9.0	100
9.5	106

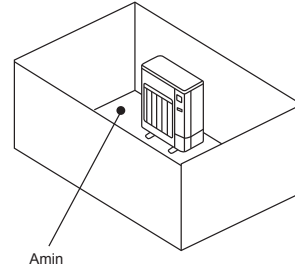

B) Install in a space with a depression height of ≤ 0.125 [m].

Height from the bottom of
0.125 [m] or less

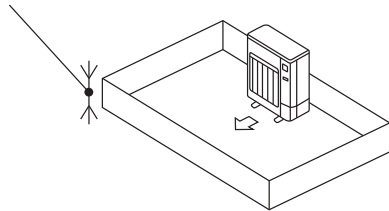

Height from the bottom of
0.125 [m] or less

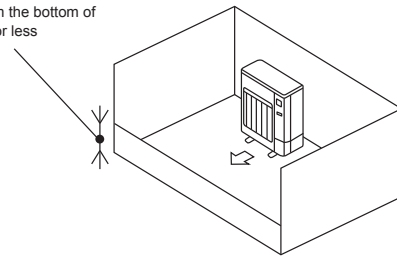

C) Create an appropriate ventilation open area.

Make sure that the width of the open area is 0.9 [m] or more and the height of the open area is 0.15 [m] or more.

However, the height from the bottom of the installation space to the bottom edge of the open area should be 0.125 [m] or less.

Open area should be 75% or more opening.

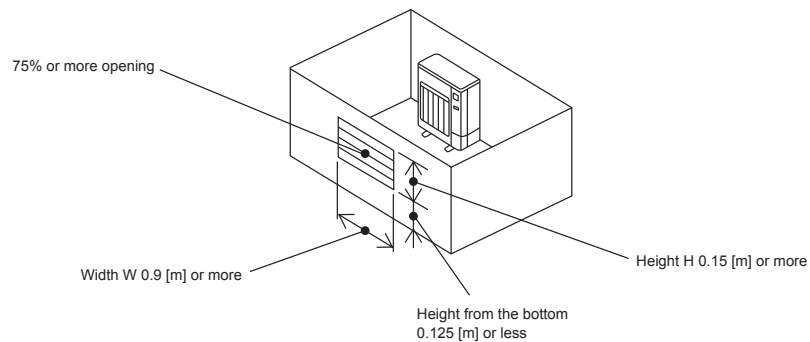

2. Installation location

■ Indoor units

Install in a room with a floor area of A_{min} or more, corresponding to refrigerant quantity M (factory-charged refrigerant + locally added refrigerant).

* For the factory-charged refrigerant amount, refer to the spec nameplate or installation manual.

For the amount to be added locally, refer to the installation manual.

Install the indoor unit so that the height from the floor to the bottom of the indoor unit is h_0 .

For wall mounted: 1.8 m or more

For ceiling suspended, cassette and ceiling concealed: 2.2 m or more

For floor standing (PSA-M): 0 m

* There are restrictions in installation height for each model, so read the installation manual for the particular unit.

Case 1: for wall mounted, ceiling suspended, cassette and concealed

M [kg]	A_{min} [m ²]
1.0	4
1.5	6
2.0	8
2.5	10
3.0	12
3.5	14
4.0	16
4.5	20
5.0	24
5.5	29
6.0	35
6.5	41
7.0	47
7.5	54
8.0	62
8.5	69
9.0	78
9.5	87

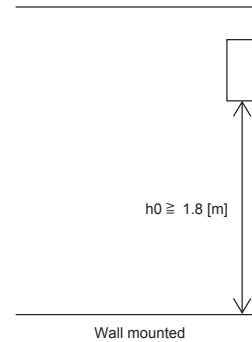

en

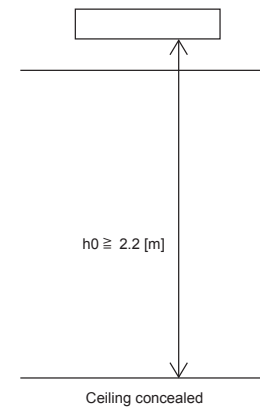
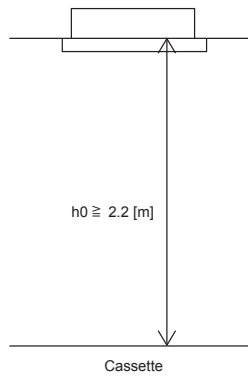
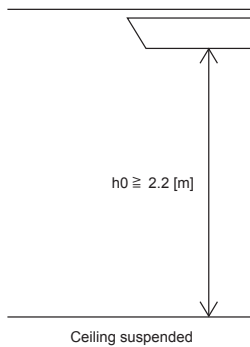

Case 2: for floor standing (PSA-M)

M [kg]	A_{min} [m ²]
< 1.84	No requirements
1.84	6
2.0	6
2.5	7
3.0	9
3.5	10
4.0	11
4.5	13
5.0	14
5.5	15
6.0	17
6.5	18
7.0	20
7.5	21
8.0	22
8.5	24
9.0	25
9.5	26

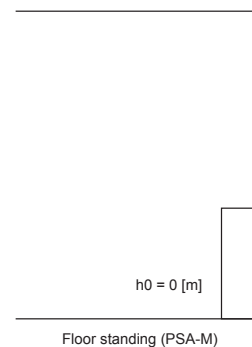

3. Installing the outdoor unit

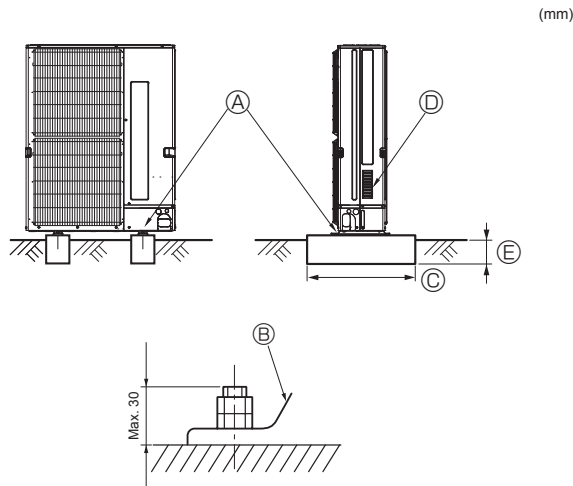

- (A) M10 (3/8") bolt
- (B) Base
- (C) As long as possible.
- (D) Vent
- (E) Set deep in the ground

- Be sure to install the unit in a sturdy, level surface to prevent rattling noises during operation. (Fig. 3-1)

<Foundation specifications>

Foundation bolt	M10 (3/8")
Thickness of concrete	120 mm
Length of bolt	70 mm
Weight-bearing capacity	320 kg

- Make sure that the length of the foundation bolt is within 30 mm of the bottom surface of the base.
- Secure the base of the unit firmly with four-M10 foundation bolts in sturdy locations.

Installing the outdoor unit

- Do not block the vent. If the vent is blocked, operation will be hindered and breakdown may result.
- In addition to the unit base, use the installation holes on the back of the unit to attach wires, etc., if necessary to install the unit. Use self-tapping screws ($\phi 5 \times 15$ mm or less) and install on site.

⚠ Warning:

- The unit must be securely installed on a structure that can sustain its weight. If the unit is mounted on an unstable structure, it may fall down and cause damage or injuries.
- The unit must be installed according to the instructions in order to minimize the risk of damage from earthquakes, typhoons, or strong winds. An incorrectly installed unit may fall down and cause damage or injuries.

■ ZM200/250 M200/250

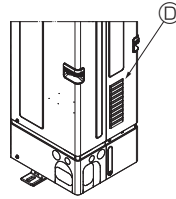

■ ZM200/250 M200/250

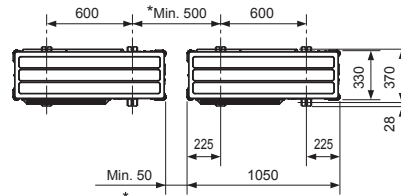

* When installing a single outdoor unit, the clearance is 15 mm or more.

Fig. 3-1

4. Installing the refrigerant piping

4.1. Precautions for devices that use R32 refrigerant

- Refer to 1.5. for precautions not included below on using air conditioners with R32 refrigerant.
- Use ester oil, ether oil, alkylbenzene oil (small amount) as the refrigeration oil applied to the flared sections.
- Use C1220 copper phosphorus, for copper and copper alloy seamless pipes, to connect the refrigerant pipes. Use refrigerant pipes with the thicknesses specified in the table to the below. Make sure the insides of the pipes are clean and do not contain any harmful contaminants such as sulfuric compounds, oxidants, debris, or dust. Always apply no-oxidation brazing when brazing the pipes, otherwise, the compressor will be damaged.

⚠ Warning:

When installing or relocating, or servicing the air conditioner, use only the specified refrigerant (R32) to charge the refrigerant lines. Do not mix it with any other refrigerant and do not allow air to remain in the lines. If air is mixed with the refrigerant, then it can be the cause of abnormal high pressure in the refrigerant line, and may result in an explosion and other hazards.

The use of any refrigerant other than that specified for the system will cause mechanical failure or system malfunction or unit breakdown. In the worst case, this could lead to a serious impediment to securing product safety.

Pipe size (mm)	ø6.35	ø9.52	ø12.7	ø15.88	ø19.05	ø22.2	ø25.4	ø28.58
Thickness (mm)	0.8	0.8	0.8	1.0	1.0	1.0	1.0	1.0

- Do not use pipes thinner than those specified above.
- Use 1/2 H or H pipes if the diameter is 19.05 mm or larger.
- Be sure to have appropriate ventilation in order to prevent ignition. Furthermore, be sure to carry out fire prevention measures that there are no dangerous or flammable objects in the surrounding area.

4. Installing the refrigerant piping

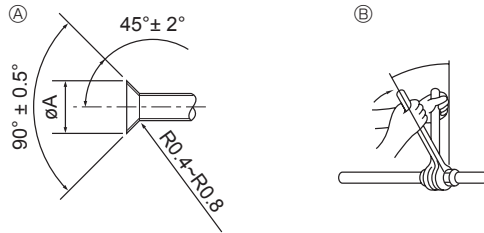

Ⓐ Flare cutting dimensions
Ⓑ Flare nut tightening torque

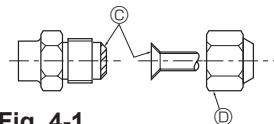

Fig. 4-1

Ⓐ (Fig. 4-1)

Copper pipe O.D. (mm)	Flare dimensions ϕA dimensions (mm)
$\phi 6.35$	8.7 - 9.1
$\phi 9.52$	12.8 - 13.2
$\phi 12.7$	16.2 - 16.6
$\phi 15.88$	19.3 - 19.7
$\phi 19.05$	23.6 - 24.0

Ⓑ (Fig. 4-1)

Copper pipe O.D. (mm)	Flare nut O.D. (mm)	Tightening torque (N·m)
$\phi 6.35$	17	14 - 18
$\phi 6.35$	22	34 - 42
$\phi 9.52$	22	34 - 42
$\phi 12.7$	26	49 - 61
$\phi 12.7$	29	68 - 82
$\phi 15.88$	29	68 - 82
$\phi 15.88$	36	100 - 120
$\phi 19.05$	36	100 - 120

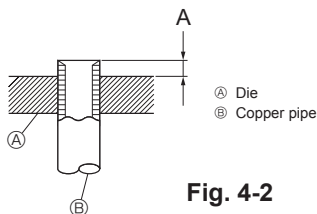

Fig. 4-2

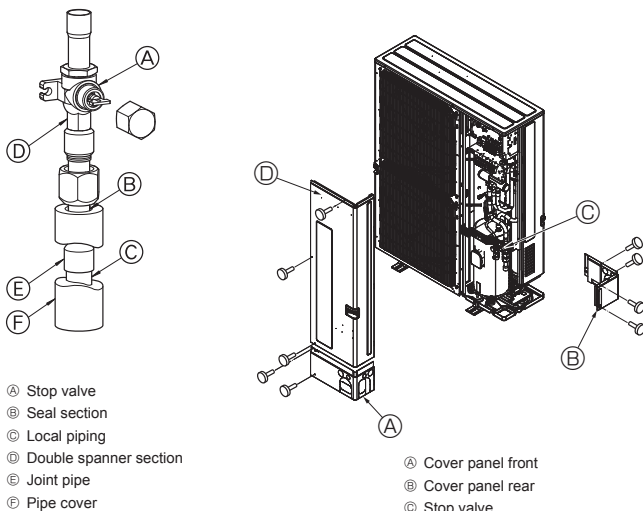
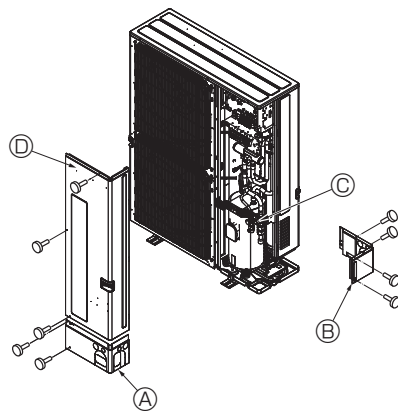

Fig. 4-3



Ⓐ Cover panel front
Ⓑ Cover panel rear
Ⓒ Stop valve
Ⓓ Service panel
Ⓔ Bend radius : 100 mm - 150 mm

Fig. 4-4

4.2. Connecting pipes (Fig. 4-1)

- When commercially available copper pipes are used, wrap liquid and gas pipes with commercially available insulation materials (heat-resistant to 100 °C or more, thickness of 12 mm or more).
- The indoor parts of the drain pipe should be wrapped with polyethylene foam insulation materials (specific gravity of 0.03, thickness of 9 mm or more).
- Apply thin layer of refrigerant oil to pipe and joint seating surface before tightening flare nut. Ⓐ
- Use two wrenches to tighten piping connections. Ⓑ
- Use leak detector or soapy water to check for gas leaks after connections are completed.
- Apply refrigerating machine oil over the entire flare seat surface. Ⓒ
- Use the flare nuts for the following pipe size. Ⓓ

		ZM200/M200	ZM250/M250
Gas side	Pipe size (mm)	$\phi 25.4$	$\phi 25.4$
Liquid side	Pipe size (mm)	$\phi 9.52$	$\phi 12.7$

- When bending the pipes, be careful not to break them. Bend radii of 100 mm to 150 mm are sufficient.
- Make sure the pipes do not contact the compressor. Abnormal noise or vibration may result.
- ① Pipes must be connected starting from the indoor unit. Flare nuts must be tightened with a torque wrench.
- ② Flare the liquid pipes and gas pipes and apply a thin layer of refrigeration oil (Applied on site).
- When usual pipe sealing is used, refer to Table 1 for flaring of R32 refrigerant pipes. The size adjustment gauge can be used to confirm A measurements.

Table 1 (Fig. 4-2)

Copper pipe O.D. (mm)	A (mm)	
	Flare tool for R32	Flare tool for R22-R407C
	Clutch type	
$\phi 6.35$ (1/4")	0 - 0.5	1.0 - 1.5
$\phi 9.52$ (3/8")	0 - 0.5	1.0 - 1.5
$\phi 12.7$ (1/2")	0 - 0.5	1.0 - 1.5
$\phi 15.88$ (5/8")	0 - 0.5	1.0 - 1.5
$\phi 19.05$ (3/4")	0 - 0.5	1.0 - 1.5

③ Use the following procedure for connecting the gas-side piping. (Fig. 4-3)

- Braze the Ⓓ Joint pipe provided to the outdoor unit using locally procured brazing materials and Ⓒ Local piping without oxygen.
- Connect the Ⓓ Joint pipe to the gas-side Stop valve. Use 2 wrenches to tighten the flare nut.
 - * If order is reversed, refrigerant leak occurs because of the part damaging by brazing fire.
- For PEA-M200, 250 The method of pipe connection is brazing connection.

		PEA-M200	PEA-M250
Gas side	Pipe size (mm)	$\phi 25.4$	$\phi 25.4$
Liquid side	Pipe size (mm)	$\phi 9.52$	$\phi 12.7$

4.3. Refrigerant piping (Fig. 4-4)

Remove the service panel Ⓓ (3 screws) and the cover panel front Ⓐ (2 screws) and cover panel rear Ⓑ (4 screws).

- Perform refrigerant piping connections for the indoor/outdoor unit when the outdoor unit's stop valve is completely closed.
- Vacuum-purge air from the indoor unit and the connection piping.
- After connecting the refrigerant pipes, check the connected pipes and the indoor unit for gas leaks. (Refer to 4.4. Refrigerant pipe airtight testing method)
- A high-performance vacuum pump is used at the stop valve service port to maintain a vacuum for an adequate time (at least one hour after reaching -101 kPa (5 Torr)) in order to vacuum dry the inside of the pipes. Always check the degree of vacuum at the gauge manifold. If there is any moisture left in the pipe, the degree of vacuum is sometimes not reached with short-time vacuum application. After vacuum drying, completely open the stop valves (both liquid and gas) for the outdoor unit. This completely links the indoor and outdoor refrigerant circuits.
 - If the vacuum drying is inadequate, air and water vapor remain in the refrigerant circuits and can cause abnormal rise of high pressure, abnormal drop of low pressure, deterioration of the refrigerating machine oil due to moisture, etc.
 - If the stop valves are left closed and the unit is operated, the compressor and control valves will be damaged.
 - Use a leak detector or soapy water to check for gas leaks at the pipe connection sections of the outdoor unit.
 - Do not use the refrigerant from the unit to purge air from the refrigerant lines.
 - After the valve work is completed, tighten the valve caps to the correct torque: 20 to 25 N·m (200 to 250 kgf·cm). Failure to replace and tighten the caps may result in refrigerant leakage. In addition, do not damage the insides of the valve caps as they act as a seal to prevent refrigerant leakage.
- Use sealant to seal the ends of the thermal insulation around the pipe connection sections to prevent water from entering the thermal insulation.

4. Installing the refrigerant piping

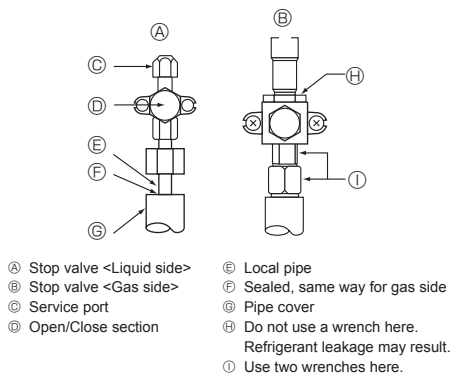

Fig. 4-5

(1)

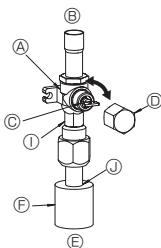

Fig. 4-6

(2)

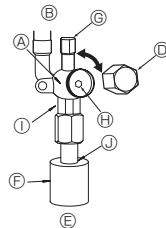
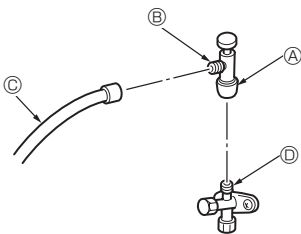

Fig. 4-7

- A Valve
- B Unit side
- C Handle
- D Cap
- E Local pipe side
- F Pipe cover
- G Service port
- H Wrench hole
- I Double spanner section
(Do not apply a spanner other than to this section. Doing so would cause coolant leaks.)
- J Seal section
(Seal the end of the heat insulation material at the pipe connection section with whatever seal material you have on hand so that water does not infiltrate the heat insulation material.)



- * The figure to the left is an example only. The stop valve shape, service port position, etc., may vary according to the model.
- * Turn section A only.
(Do not further tighten sections B and C together.)

- C Charge hose
- D Service port

Fig. 4-8

4.4. Refrigerant pipe airtight testing method (Fig. 4-5)

(1) Connect the testing tools.

- Make sure the stop valves A B are closed and do not open them.
- Add pressure to the refrigerant lines through the service port C of the liquid stop valve A.

(2) Do not add pressure to the specified pressure all at once; add pressure little by little.

- ① Pressurize to 0.5 MPa (5 kgf/cm²G), wait five minutes, and make sure the pressure does not decrease.
- ② Pressurize to 1.5 MPa (15 kgf/cm²G), wait five minutes, and make sure the pressure does not decrease.
- ③ Pressurize to 4.15 MPa (41.5 kgf/cm²G) and measure the surrounding temperature and refrigerant pressure.

(3) If the specified pressure holds for about one day and does not decrease, the pipes have passed the test and there are no leaks.

- If the surrounding temperature changes by 1 °C, the pressure will change by about 0.01 MPa (0.1 kgf/cm²G). Make the necessary corrections.

(4) If the pressure decreases in steps (2) or (3), there is a gas leak. Look for the source of the gas leak.

4.5. Stop valve opening method

The stop valve opening method varies according to the outdoor unit model. Use the appropriate method to open the stop valves.

(1) Gas side (Fig. 4-6)

① Remove the cap, pull the handle toward you and rotate 1/4 turn in a counterclockwise direction to open.

② Make sure that the stop valve is open completely, push in the handle and rotate the cap back to its original position.

(2) Liquid side (Fig. 4-7)

① Remove the cap and turn the valve rod counterclockwise as far as it will go with the use of a 4 mm hexagonal wrench. Stop turning when it hits the stopper. (ø9.52: Approximately 10 revolutions)

② Make sure that the stop valve is open completely, push in the handle and rotate the cap back to its original position.

Refrigerant pipes are protectively wrapped

- The pipes can be protectively wrapped up to a diameter of ø90 before or after connecting the pipes. Cut out the knockout in the pipe cover following the groove and wrap the pipes.

Pipe inlet gap

- Use putty or sealant to seal the pipe inlet around the pipes so that no gaps remain. (If the gaps are not closed, noise may be emitted or water and dust will enter the unit and breakdown may result.)

Precautions when using the charge valve (Fig. 4-8)

Do not tighten the service port too much when installing it, otherwise, the valve core could be deformed and become loose, causing a gas leak.

After positioning section B in the desired direction, turn section A only and tighten it. Do not further tighten sections A and B together after tightening section A.

Warning:

When installing the unit, securely connect the refrigerant pipes before starting the compressor.

4.6. Addition of refrigerant

- Additional charging is not necessary if the pipe length does not exceed 30 m.
- If the pipe length exceeds 30 m, charge the unit with additional R32 refrigerant according to the permitted pipe lengths in the chart below.

* When the unit is stopped, charge the unit with the additional refrigerant through the liquid stop valve after the pipe extensions and indoor unit have been vacuumized.

When the unit is operating, add refrigerant to the gas check valve using a safety charger. Do not add liquid refrigerant directly to the check valve.

* After charging the unit with refrigerant, note the added refrigerant amount on the service label (attached to the unit).

Refer to the "1.5. Using R32 refrigerant air conditioners" for more information.

- Be careful when installing multiple units. Connecting to an incorrect indoor unit can lead to abnormally high pressure and have a serious effect on operation performance.

◎ R32 maintenance refilling: Before servicing refilling the equipment with R32 to ensure that there is no risk of explosion from electrical sparks it must be ensured that the equipment machine is 100% disconnected from the mains supply.

Outdoor unit	A+B+C+D						◎Maximum amount of refrigerant
	Amount of additional refrigerant charge (kg)						
	30 m and less	31 - 40 m	41 - 50 m	51 - 60 m	61 - 70 m	71 - 100 m	
ZM200	No additional charge necessary	0.4 kg	0.8 kg	1.2 kg	1.6 kg	Calculate the amount of additional refrigerant charge using formula provided next page	9.2 kg
ZM250		0.6 kg	1.2 kg	1.8 kg	2.4 kg		9.2 kg
M200		0.4 kg	0.8 kg	1.2 kg	1.6 kg	-	7.2 kg
M250		0.6 kg	1.2 kg	1.8 kg	2.4 kg		9.2 kg

4. Installing the refrigerant piping

When length exceeds 70 m

When the total length of the piping exceeds 70 m, calculate the amount of additional charge based on the following requirements.
 Note: If the calculation produces a negative number (i.e. a "minus" charge), if of calculation results in an amount that is less than the "Additional charge amount for 70 m", perform the additional charge using the amount shown in "Additional charge amount for 70 m".

Amount of additional charge (kg)	=	Main piping: Liquid line size ø12.7 overall length × 0.06 (m) × 0.06 (kg/m)	+	Main piping: Liquid line size ø9.52 overall length × 0.04 (Gas line: ø25.4) (m) × 0.04 (kg/m)	+	Branch piping: Liquid line size ø9.52 overall length × 0.03 (Gas line: ø15.88) (m) × 0.03 (kg/m)	+	Branch piping: Liquid line size ø6.35 overall length × 0.01 (m) × 0.01 (kg/m)	-	<table border="1"> <tr> <td>ZM200</td> <td>1.2 (kg)</td> </tr> <tr> <td>ZM250</td> <td>1.8 (kg)</td> </tr> </table>	ZM200	1.2 (kg)	ZM250	1.8 (kg)
ZM200	1.2 (kg)													
ZM250	1.8 (kg)													
Maximum additional charge		ZM200	2.9 kg											
		ZM250	2.4 kg											
Additional charge amount for 70 meters		ZM200	1.6 kg											
		ZM250	2.4 kg											

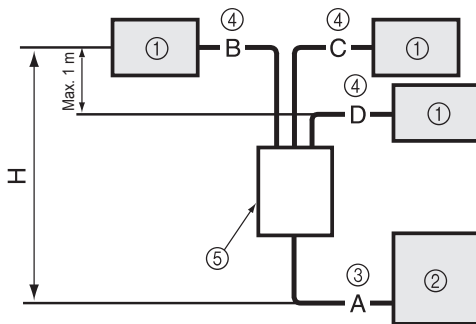

- ① Indoor unit
- ② Outdoor unit
- ③ Main piping
- ④ Branch piping
- ⑤ Multi distribution pipe (option)

Outdoor unit : ZM250 A: ø12.7.....65 m
 Indoor unit 1 : ZM71 B: ø9.52.....5 m
 Indoor unit 2 : ZM71 C: ø9.52.....5 m
 Indoor unit 3 : ZM71 D: ø9.52.....5 m
 Main piping ø12.7 is A = 65 m
 Branch piping ø9.52 is B + C + D = 15 m
 Therefore, the amount of additional charge is: 65 × 0.06 + 15 × 0.04
 - 1.8 = 2.7(kg)
 (Fractions are rounded up)

Fig. 4-9

Refilling refrigerant charge (kg) for less than 30 m (Chargeless pipe length)

Outdoor unit	5 m and less	6 - 10 m	11 - 15 m	16 - 20 m	21 - 25 m	26 - 30 m
ZM200	5.6	5.7	5.9	6.0	6.2	6.3
ZM250	6.0	6.2	6.3	6.5	6.7	6.8
M200	4.9	5.1	5.2	5.4	5.5	5.6
M250	6.0	6.2	6.3	6.5	6.7	6.8

Maximum pipe length (ZM200-250)

Liquid pipe (mm)	O.D.	ø9.52				ø12.7				ø15.88			
	Thickness	t0.8				t0.8				t1.0			
Gas pipe (mm)	O.D.	ø19.05	ø22.2	ø25.4	ø28.58	ø19.05	ø22.2	ø25.4	ø28.58	ø22.2	ø25.4	ø28.58	ø31.75
	Thickness	t1.0	t1.0	t1.0	t1.0	t1.0	t1.0	t1.0	t1.0	t1.0	t1.0	t1.0	t1.1
ZM200	□	□	□	○	○	□	□	○	○	△	△	△	△
	20m [20m]	50m [30m]	Standard size 100m [30m]	100m [30m]	100m [20m]	50m [30m]	100m [30m]	100m [30m]	100m [30m]	50m [20m]	50m [20m]	50m [20m]	50m [20m]
ZM250	□	□	○	○	□	□	Standard size	□	□	△	△	△	△
	20m [20m]	50m [30m]	100m [30m]	100m [30m]	20m [20m]	50m [30m]	100m [30m]	100m [30m]	100m [30m]	50m [20m]	50m [20m]	50m [20m]	50m [20m]

Note : Be sure to use hard (tempered) one for pipe over ø19.05.

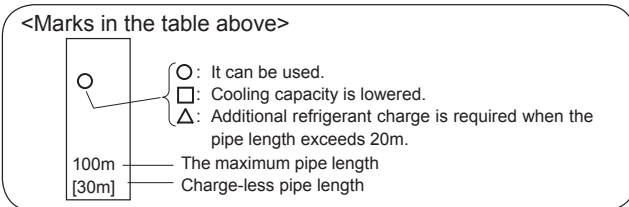

■ ZM200, 250

Additional refrigerant amount when the liquid pipe of the larger diameter is used.

1:1 system

Liquid pipe	When the pipe length exceeds 20 m
ø15.88	Additional refrigerant amount Δw (g) = 180 × Pipe length (m) - 3000

* Δw (g) ≤ 0 : Additional charge is not necessary.

Simultaneous twin/triple/quadruple system

When the pipe length (main piping and branch piping) exceeds 20 m	
Additional refrigerant amount Δw (g) = (180 × L1) + (120 × L2) + (90 × L3) + (30 × L4) - 3000	

L1 : ø15.88 liquid pipe length (m)

L2 : ø12.7 liquid pipe length (m)

L3 : ø9.52 liquid pipe length (m)

L4 : ø6.35 liquid pipe length (m)

* Δw (g) ≤ 0 : Additional charge is not necessary.

4. Installing the refrigerant piping

4.7. Precautions when reusing existing R22 refrigerant pipes

- Refer to the flowchart below to determine if the existing pipes can be used and if it is necessary to use a filter dryer.
- If the diameter of the existing pipes is different from the specified diameter, refer to technological data materials to confirm if the pipes can be used.

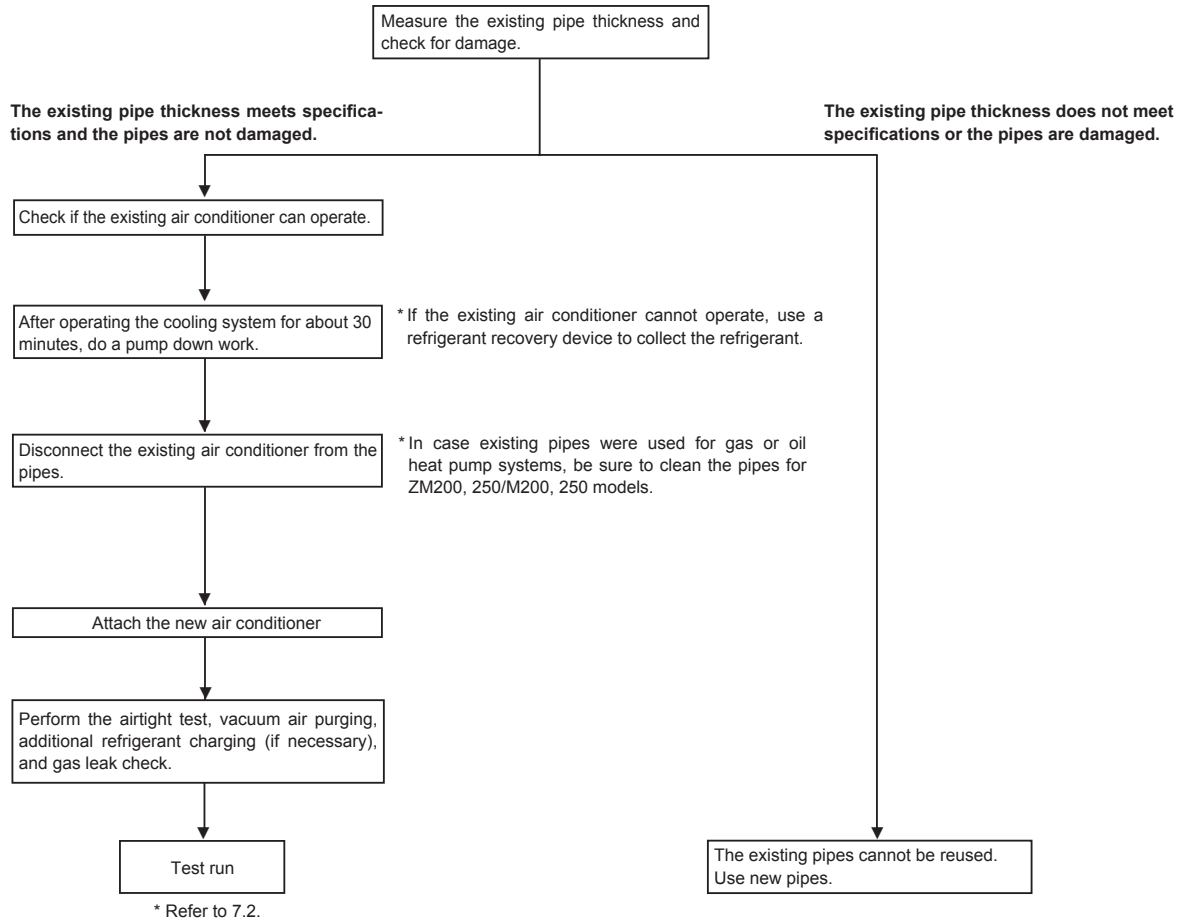

<Limits of refrigerant piping installation>

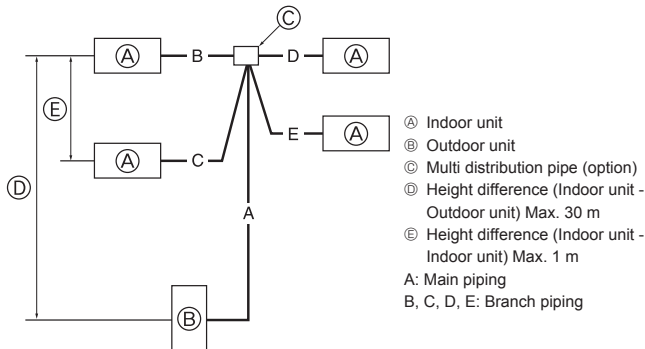

ZM200, 250 : $A+B+C+(D)(+E) \leq 100$ m

M200, 250 : $A+B+C+(D)(+E) \leq 70$ m

* "D" is for triple.

* "E" is for four (quadruple).

Fig. 4-10

4.8. For twin/triple/quadruple combination (Fig. 4-10)

- When this unit is used as a FREE COMPO MULTI unit, install the refrigerant piping with the restrictions indicated in the drawing on the left. In addition, if the restrictions are going to be exceeded, or if there are going to be combinations of indoor and outdoor units, refer to installation instructions for the indoor unit for details about the installation.

Outdoor unit	Permissible total piping length A+B+C+D+E	A+B or A+C or A+D or A+E	Charge-less piping length A+B+C+D+E
ZM200 ZM250	100 m and less	100 m and less	30 m and less
M200 M250	70 m and less	70 m and less	30 m and less

Outdoor unit	B-C or B-D or B-E or C-D or C-E or D-E	No. of bends
ZM200, 250	8 m and less	Within 15

5. Drainage piping work

Outdoor unit drainage pipe connection

When drain piping is necessary, use the drain socket or the drain pan (option).

	ZM200, 250/M200, 250
Drain socket	PAC-SG61DS-E
Drain pan	PAC-SH97DP-E

6. Electrical work

6.1. Outdoor unit (Fig. 6-1, Fig. 6-2)

- ① Remove the service panel.
 - ② Wire the cables referring to the Fig. 6-1 and the Fig. 6-2.
- ▶ Except PEA-M200, 250

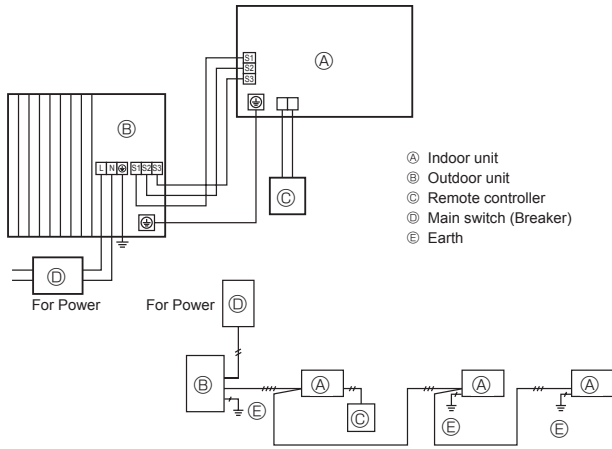

Fig. 6-1

■ ZM200, 250
M200, 250

■ ZM200, 250Y
M200, 250Y

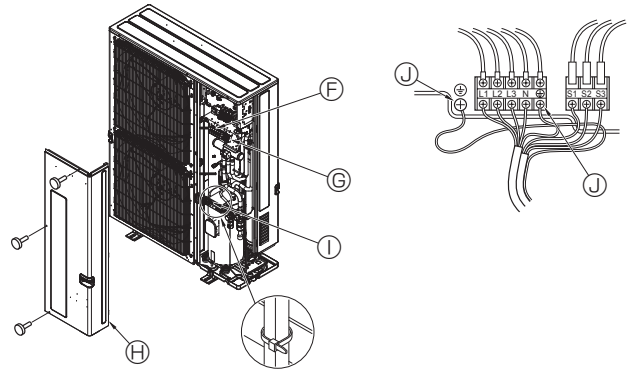

Fig. 6-2

- Ⓜ Terminal block
 - Ⓝ Indoor/Outdoor connection terminal block (S1, S2, S3)
 - Ⓞ Service panel
 - Ⓟ Clamp
- * Clamp the cables so that they do not contact the center of the service panel or the gas valve.

Note :
If the protective sheet for the electrical box is removed during servicing, be sure to reinstall it.

Caution:
Be sure to install N-Line. Without N-Line, it could cause damage to unit.

▶ In case of PEA-M200, 250

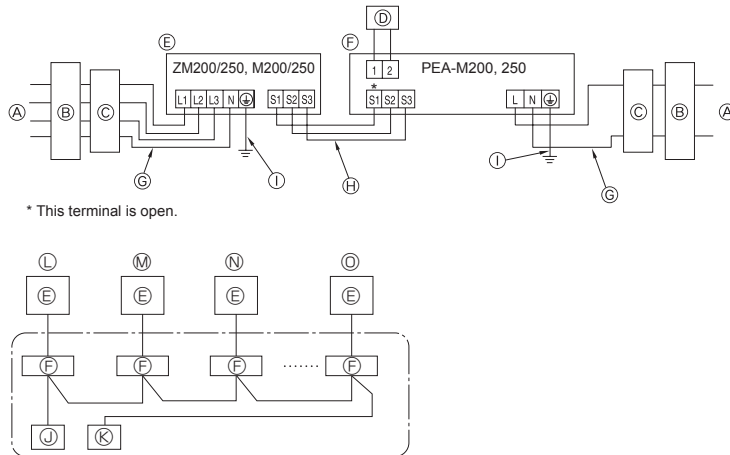

Fig. 6-3

- Ⓐ Power supply
- Ⓑ Earth leakage breaker
- Ⓒ Circuit breaker or local switch
- Ⓓ LCD remote controller
- Ⓔ Outdoor unit
- Ⓕ Indoor unit
- Ⓖ Power cable wiring
- Ⓗ Indoor/outdoor connection wiring
- Ⓘ Grounding
- Ⓚ Main remote controller
- Ⓛ Subordinate remote controller
- Ⓜ Standard (Refrigerant address = 00)
- Ⓝ Refrigerant address = 01
- Ⓞ Refrigerant address = 02
- Ⓟ Refrigerant address = 15

en

6. Electrical work

6.2. Field electrical wiring

Outdoor unit model		ZM200, 250/M200, 250
Outdoor unit power supply		3N~ (3 ph 4-wires), 50 Hz, 400 V
Outdoor unit input capacity Main switch (Breaker)		*1 32 A
Wiring Wire No. x size (mm ²)	Outdoor unit power supply	*5 5 × Min. 4
	Indoor unit-Outdoor unit	*2 Cable length 50m: 3×4 (Polar) / Cable length 80m: 3×6 (Polar)
	Indoor unit-Outdoor unit earth	*2 1 × Min. 2.5
	Remote controller-Indoor unit	*3 2 × 0.3 (Non-polar)
Circuit rating	Outdoor unit L-N (single)	*4 230 VAC
	Outdoor unit L1-N, L2-N, L3-N (3 phase)	*4 230 VAC
	Indoor unit-Outdoor unit S1-S2	*4 24 VDC
	Indoor unit-Outdoor unit S2-S3	*4 12 VDC

*1. A breaker with at least 3.0 mm contact separation in each poles shall be provided. Use earth leakage breaker (NV).

Make sure that the current leakage breaker is one compatible with higher harmonics.

Always use a current leakage breaker that is compatible with higher harmonics as this unit is equipped with an inverter.

The use of an inadequate breaker can cause the incorrect operation of inverter.

*2. (ZM200, 250/M200, 250)

Max. 80 m Total Max. including all indoor/outdoor connection is 80 m.

• Use one cable for S1 and S2 and another for S3 as shown in the picture.

• Max. 50 m Total Max. for PEA. Wiring size 3 × 1.5 (Polar).

*3. The 10 m wire is attached in the remote controller accessory.

*4. The figures are NOT always against the ground.

S3 terminal has 24 VDC against S2 terminal. However between S3 and S1, these terminals are NOT electrically insulated by the transformer or other device.

*5. In multi-phase appliances, the colour of the neutral conductor of the supply cord, if any, shall be blue.

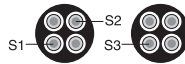

en

Notes: 1. Wiring size must comply with the applicable local and national code.

2. Power supply cords and Indoor/Outdoor unit connecting cords shall not be lighter than polychloroprene sheathed flexible cord. (Design 60245 IEC 57)

3. Use an earth wire which is longer than the other cords so that it will not become disconnected when tension is applied.

4. Use self-extinguishing distribution cables for power supply wiring.

5. Properly route wiring so as not to contact the sheet metal edge or a screw tip.

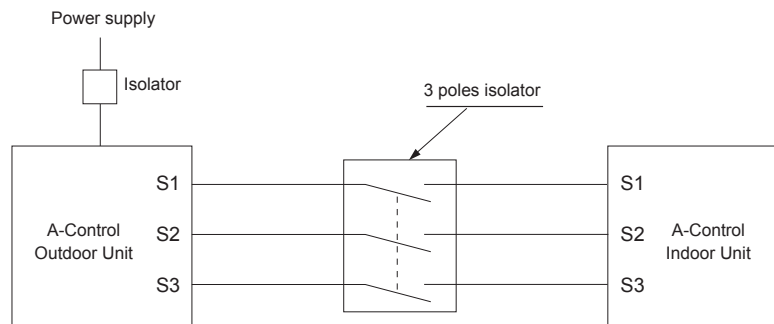

⚠ Warning:

- In case of A-control wiring, there is high voltage potential on the S3 terminal caused by electrical circuit design that has no electrical insulation between power line and communication signal line. Therefore, please turn off the main power supply when servicing. And do not touch the S1, S2, S3 terminals when the power is energized. If isolator should be used between indoor unit and outdoor unit, please use 3-pole type.

Never splice the power cable or the indoor-outdoor connection cable, otherwise it may result in a smoke, a fire or communication failure.

INDOOR-OUTDOOR CONNECTING CABLE (ZM200, 250/M200, 250)

Cross section of cable	Wire size (mm ²)	Number of wires	Polarity	L (m)*6
Round	2.5	3	Clockwise : S1-S2-S3 * Pay attention to stripe of yellow and green	(30) *2
Flat	2.5	3	Not applicable (Because center wire has no cover finish)	Not applicable *5
Flat	1.5	4	From left to right : S1-Open-S2-S3	(18) *3
Round	2.5	4	Clockwise : S1-S2-S3-Open * Connect S1 and S3 to the opposite angle	(30) *4

*1 :Power supply cords of appliances shall not be lighter than design 60245 IEC or 227 IEC.

*2 :In case that cable with stripe of yellow and green is available.

*3 :In case of regular polarity connection (S1-S2-S3), wire size is 1.5 mm².

*4 :In case of regular polarity connection (S1-S2-S3).

*5 :In the flat cables are connected as this picture, they can be used up to 30 m.

*6 :Mentioned cable length is just a reference value.

It may be different depending on the condition of installation, humidity or materials, etc.

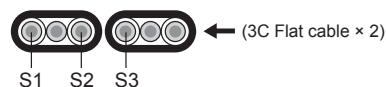

Be sure to connect the indoor-outdoor connecting cables directly to the units (no intermediate connections).

Intermediate connections can lead to communication error if water enters the cables and causes insufficient insulation to ground or a poor electrical contact at the intermediate connection point.

7. Test run

7.1. Before test run

- ▶ After completing installation and the wiring and piping of the indoor and outdoor units, check for refrigerant leakage, looseness in the power supply or control wiring, wrong polarity, and no disconnection of one phase in the supply.
- ▶ Use a 500-volt megohmmeter to check that the resistance between the power supply terminals and ground is at least 1 MΩ.
- ▶ Do not carry out this test on the control wiring (low voltage circuit) terminals.

⚠ Warning:

Do not use the air conditioner if the insulation resistance is less than 1 MΩ.

Insulation resistance

After installation or after the power source to the unit has been cut for an extended period, the insulation resistance will drop below 1 MΩ due to refrigerant accumulation in the compressor. This is not a malfunction. Perform the following procedures.

1. Remove the wires from the compressor and measure the insulation resistance of the compressor.
2. If the insulation resistance is below 1 MΩ, the compressor is faulty or the resistance dropped due the accumulation of refrigerant in the compressor.
3. After connecting the wires to the compressor, the compressor will start to warm up after power is supplied. After supplying power for the times indicated below, measure the insulation resistance again.

- The insulation resistance drops due to accumulation of refrigerant in the compressor. The resistance will rise above 1 MΩ after the compressor is warmed up for 12 hours.
(The time necessary to warm up the compressor varies according to atmospheric conditions and refrigerant accumulation.)
 - To operate the compressor with refrigerant accumulated in the compressor, the compressor must be warmed up at least 12 hours to prevent breakdown.
4. If the insulation resistance rises above 1 MΩ, the compressor is not faulty.

⚠ Caution:

- **The compressor will not operate unless the power supply phase connection is correct.**
- **Turn on the power at least 12 hours before starting operation.**
- Starting operation immediately after turning on the main power switch can result in severe damage to internal parts. Keep the power switch turned on during the operational season.

▶ **The followings must be checked as well.**

- The outdoor unit is not faulty. LED1 and LED2 on the control board of the outdoor unit flash when the outdoor unit is faulty.
- Both the gas and liquid stop valves are completely open.
- A protective sheet covers the surface of the DIP switch panel on the control board of the outdoor unit. Remove the protective sheet to operate the DIP switches easily.

en

7.2. Test run

7.2.1. Using SW4 in outdoor unit

SW4-1	ON	Cooling operation
SW4-2	OFF	
SW4-1	ON	Heating operation
SW4-2	ON	

- * After performing the test run, set SW4-1 to OFF.
- After power is supplied, a small clicking noise may be heard from the inside of the outdoor unit. The electronic expansion valve is opening and closing. The unit is not faulty.
- A few seconds after the compressor starts, a clanging noise may be heard from the inside of the outdoor unit. The noise is coming from the check valve due to the small difference in pressure in the pipes. The unit is not faulty.

The test run operation mode cannot be changed by DIP switch SW4-2 during the test run. (To change the test run operation mode during the test run, stop the test run by DIP switch SW4-1. After changing the test run operation mode, resume the test run by switch SW4-1.)

7.2.2. Using remote controller

Refer to the indoor unit installation manual.

Note : Occasionally, vapor that is made by the defrost operation may seem as if smoke come up from the outdoor unit.

8. Special Functions

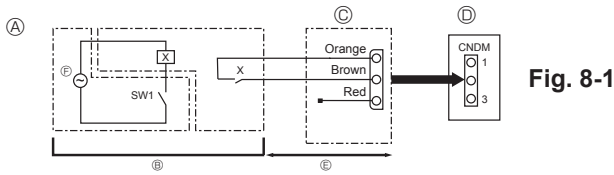

Fig. 8-1

- A Circuit diagram example (low noise mode) D Outdoor unit control board
 B On-site arrangement E Max. 10 m
 C External input adapter (PAC-SC36NA-E) F Power supply for relay
 X: Relay

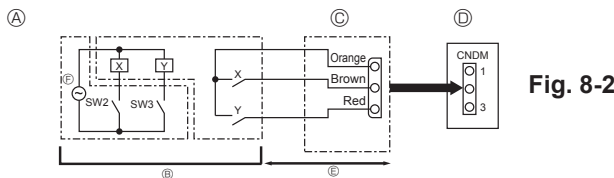

Fig. 8-2

- A Circuit diagram example (Demand function) C External input adapter (PAC-SC36NA-E)
 B On-site arrangement D Outdoor unit control board
 E Max. 10 m
 F Power supply for relay
 X, Y: Relay

8.1. Low noise mode (on-site modification) (Fig. 8-1)

By performing the following modification, operation noise of the outdoor unit can be reduced by about 3-4 dB.

The low noise mode will be activated when a commercially available timer or the contact input of an ON/OFF switch is added to the CNDM connector (option) on the control board of the outdoor unit.

- The ability varies according to the outdoor temperature and conditions, etc.

- Complete the circuit as shown when using the external input adapter (PAC-SC36NA-E). (Option)
- SW7-1 (Outdoor unit control board): OFF
- SW1 ON: Low noise mode
SW1 OFF: Normal operation

8.2. Demand function (on-site modification) (Fig. 8-2)

By performing the following modification, energy consumption can be reduced to 0-100% of the normal consumption.

The demand function will be activated when a commercially available timer or the contact input of an ON/OFF switch is added to the CNDM connector (option) on the control board of the outdoor unit.

- Complete the circuit as shown when using the external input adapter (PAC-SC36NA-E). (Option)
- By setting SW7-1 on the control board of the outdoor unit, the energy consumption (compared to the normal consumption) can be limited as shown below.

	SW7-1	SW2	SW3	Energy consumption
Demand function	ON	OFF	OFF	100%
		ON	OFF	75%
		ON	ON	50%
		OFF	ON	0% (Stop)

8.3. Refrigerant collecting (pump down)

Perform the following procedures to collect the refrigerant when moving the indoor unit or the outdoor unit.

- Supply power (circuit breaker).
 - When power is supplied, make sure that "CENTRALLY CONTROLLED" is not displayed on the remote controller. If "CENTRALLY CONTROLLED" is displayed, the refrigerant collecting (pump down) cannot be completed normally.
 - Start-up of the indoor-outdoor communication takes about 3 minutes after the power (circuit breaker) is turned on. Start the pump-down operation 3 to 4 minutes after the power (circuit breaker) is turned ON.
- After the liquid stop valve is closed, set the SWP switch on the control board of the outdoor unit to ON. The compressor (outdoor unit) and ventilators (indoor and outdoor units) start operating and refrigerant collecting operation begins. LED1 and LED2 on the control board of the outdoor unit are lit.
 - Only set the SWP switch (push-button type) to ON if the unit is stopped. However, even if the unit is stopped and the SWP switch is set to ON less than 3 minutes after the compressor stops, the refrigerant collecting operation cannot be performed. Wait until compressor has been stopped for 3 minutes and then set the SWP switch to ON again.

- Because the unit automatically stops in about 2 to 3 minutes when the refrigerant collecting operation is completed (LED1 off, LED2 lit), be sure to quickly close the gas stop valve. If LED1 is lit and LED2 is off and the outdoor unit is stopped, refrigerant collection is not properly performed. Open the liquid stop valve completely, and then repeat step ② after 3 minutes have passed.
 - If the refrigerant collecting operation has been completed normally (LED1 off, LED2 lit), the unit will remain stopped until the power supply is turned off.

- Turn off the power supply (circuit breaker).

- Note that when the extension piping is very long with large refrigerant amount, it may not be possible to perform a pump-down operation. When performing the pump-down operation, make sure that the low pressure is lowered to near 0 MPa (gauge).

Warning:

When pumping down the refrigerant, stop the compressor before disconnecting the refrigerant pipes. The compressor may burst if air etc. get into it.

9. System control (Fig. 9-1)

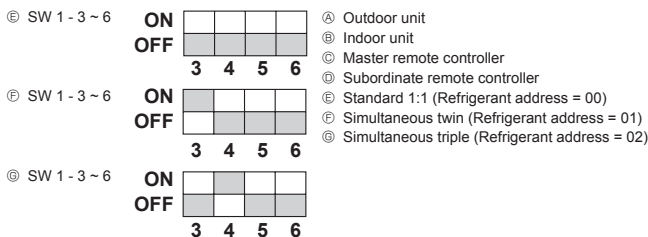

Fig. 9-1

- Set the refrigerant address using the DIP switch of the outdoor unit.

- Wiring from the Remote Control

This wire is connected to TB5 (terminal board for remote controller) of the indoor unit (non-polar).

- When a Different Refrigerant System Grouping is Used.

Up to 16 refrigerant systems can be controlled as one group using the slim MA remote controller.

Note:

In single refrigerant system (twin/triple), there is no need of wiring ②.

SW1
Function table



Function	Operation according to switch setting	
	ON	OFF
1 Compulsory defrosting	Start	Normal
2 Error history clear	Clear	Normal
3 Refrigerant system address setting	Settings for outdoor unit addresses 0 to 15	

10. Specifications

Outdoor model		ZM200	ZM250	M200	M250
Power supply (V / Phase / Hz)		400 / Three / 50			
Dimensions (W × H × D)		1050 × 1338 × 330 (+40)			
Sound level *1	Cooling	59	59	58	59
	Heating	62	62	60	62

*1 Measured under rated operation frequency.

11. Serial number

■ The serial number is indicated on the SPEC NAME PLATE.

□ □ **U**

□ □ □ □ □

Sequential number for each unit: 00001–99999

U (outdoor unit)

Month of manufacture: 4, 5, 6, 7, 8, 9, X (10), Y (11), Z (12), 1, 2, 3

Last digit of the company's fiscal year (western calendar): 2020 → 0, 2021 → 1

This product is made in Japan.

en

EC DECLARATION OF CONFORMITY
EG-KONFORMITÄTSERKLÄRUNG
DECLARATION DE CONFORMITÉ CE
EG-CONFORMITEITSVERKLARING
DECLARACIÓN DE CONFORMIDAD CE
DICHIARAZIONE DI CONFORMITÀ CE
ΔΗΛΩΣΗ ΠΙΣΤΟΤΗΤΑΣ ΕΚ

DECLARAÇÃO DE CONFORMIDADE CE
EU-OVERENSSTEMMELSESERKLÆRING
EG-DEKLARATION OM ØVERENSSTÅMMELSE
EC UYGUNLUK BEYANI
ДЕКЛАРАЦИЯ СООТВЕТСТВИЯ НОРМАМ ЕС
ДЕКЛАРАЦІЯ ВІДПОВІДНОСТІ НОРМАМ ЕС
ЕС ДЕКЛАРАЦІЯ ЗА СЪОТВЕТСТВИЕ

DEKLARACJA ZGODNOŚCI WE
CE-ERKLÆRING OM SAMSVAR
EY-VAATIMUSTENMUKAISUUSVAKUUTUS
ES PROHLÁŠENÍ O SHODĚ
VYHLÁSENIE O ZHODE ES
EK MEGFELELŐSÉGI NYILATKOZAT
IZJAVA O SKLADNOSTI ES

DECLARAȚIE DE CONFORMITATE CE
EU VASTAVUSDEKLARATSIOON
EK ATBILSTĪBAS DEKLARĀCIJA
EB ATITIKTIES DEKLARĀCIJA
EC IZJAVA O SUKLADNOSTI
EZ IZJAVA O USAGLAŠENOSTI

MITSUBISHI ELECTRIC CORPORATION
TOKYO BUILDING, 2-7-3, MARUNOUCHI, CHIYODA-KU, TOKYO 100-8310, JAPAN

hereby declares under its sole responsibility that the air conditioners and heat pumps described below for use in residential, commercial and light-industrial environments:
erklært hiermit auf seine alleinige Verantwortung, dass die Klimaanlage und Wärmepumpen für das häusliche, kommerzielle und leicht-industrielle Umfeld wie unten beschrieben:
déclare par la présente et sous sa propre responsabilité que les climatiseurs et les pompes à chaleur décrits ci-dessous, destinés à un usage dans des environnements résidentiels, commerciaux et d'industrie légère :
verklaart hierbij onder eigen verantwoordelijkheid dat de voor residentiële, commerciële en licht-industriële omgevingen bestemde airconditioners en warmtepompen zoals onderstaand beschreven:
por la presente declara bajo su única responsabilidad que los acondicionadores de aire y bombas de calor descritas a continuación para su uso en entornos residenciales, comerciales y de industria ligera:
conferma con la presente, sotto la sua esclusiva responsabilità, che i condizionatori d'aria e le pompe di calore descritti di seguito e destinati all'utilizzo in ambienti residenziali, commerciali e semi-industriali:
με το παρόν πιστοποιώ με αποκλειστική της ευθύνη ότι οι τα κλιματιστικά και οι αντλίες θέρμανσης που περιγράφονται παρακάτω για χρήση σε οικιακό, επαγγελματικό και ελαφριάς βιομηχανίας περιβάλλοντα:
através da presente declara sob sua única responsabilidade que os aparelhos de ar condicionado e bombas de calor abaixo descritos para uso residencial, comercial e de indústria ligeira:
erklærer hermed under eneansvar, at de herunder beskrevne airconditionanlæg og varmepumper til brug i privat boligbyggeri, erhvervsområder og inden for let industri:
intygar harmed att luftkonditioneringarna och värmepumparna som beskrivs nedan för användning i bostäder, kommersiella miljöer och lätta industriella miljöer:
ev, ticaret ve hafif sanayi ortamlarında kullanım amaçlı üretilen ve aşağıda açıklanan klima ve ısıtma pompalarıyla ilgili aşağıdaki hususları yalnızca kendi sorumluluğunda beyan eder:
настоящим заявляет и берет на себя исключительную ответственность за то, что кондиционеры и тепловые насосы, описанные ниже и предназначенные для эксплуатации в жилых помещениях, торговых залах и на предприятиях легкой промышленности:
цим заявляю, беру на себе полную відповідальність за це, що кондиціонери й теплові насоси, описані нижче й призначені для використання в житлових приміщеннях, торговельних залах і на підприємствах легкої промисловості:
декларира на своя собствена отговорност, че климатичите и термopомпите, описани по-долу, за употреба в жилищни, търговски и леки промишлени условия:
pniejszym oświadczam na swoją wyłączną odpowiedzialność, że klimatyzatory i pompy ciepła opisane poniżej, są przeznaczone do zastosowań w środowisku mieszkalnym, handlowym i lekko uprzemysłowionym:
erklærer et fullstendig ansvar for undernevnte klimaanlegg og varmepumper ved bruk i boliger, samt kommersielle og lettindustrielle miljøer:
vakuuttaa täten yksinomaista vastuutaan, että jäljempänä kuvattut asuinrakennuksiin, pientaloisuuskäyttöön ja kaupalliseen käyttöön tarkoitettua ilmastointilaitteita ja lämpöpumpuita:
tímto na vlastní odpovědnost prohlašuje, že níže popsané klimatizační jednotky a tepelná čerpadla pro použití v obytných prostředích, komerčních prostředích a prostředích lehkého průmyslu:
týmto na svoju výlučnú zodpovednosť vyhlasuje, že nasledovné klimatizačné jednotky a tepelné čerpadlá určené na používanie v obytných a obchodných priestoroch a v prostredí ľahkého priemyslu:
allulrott kizárolágos felelősségére nyilatkozik, hogy az alábbi lakossági, kereskedelmi és kisipari környezetben való használatra szánt klímaberendezések és hőszivattyúk:
izjavlja pod izključno lastno odgovornostjo, da so spodaj navedene klimatske naprave in toplotne črpalke, namenjene uporabi v stanovanjskih, komercialnih in lahkoindustrijskih okoljih:
declară, prin prezenta, pe proprie răspundere, faptul că aparatele de climatizare și pompele de căldură descrise mai jos și destinate utilizării în medii rezidențiale, comerciale și din industria ușoară:
kinnitab käesolevaga oma ainuvastutuse, et allpool toodud kliimaseadmed ja soojustpumbad on mõeldud kasutamiseks elu-, äri- ja kergtööstuskeskkondades:
ar šo, vienpersoniski uzņemoties atbildību, paziņo, ka tālāk aprakstītie gaisa kondicionētāji un siltumsūkņi ir paredzēti lietošanai dzīvojamajās, komercdarbības un vieglās rūpniecības telpās.
šiuo vien tik savo atsakomybę pareiškia, kad toliau apibūdinti oro kondicionieriai ir šilumos siurbiai skirti naudoti gyvenamosiose, komercinėse ir lengvosios pramonės aplinkose:
ovime izjavljuje pod isključivom odgovornošću da su klimatizacijski uređaji i toplinske dizalice opisane u nastavku namijenjeni za upotrebu u stambenim i poslovnim okruženjima te okruženjima lake industrije:
ovim izjavljuje na svoju isključivu odgovornost da su klima-uređaji i toplotne pumpe opisane u daljem tekstu za upotrebu u stambenim, komercijalnim okruženjima i okruženjima sa lakom industrijom:

MITSUBISHI ELECTRIC, PUZ-M200YKA*, PUZ-M250YKA*
PUZ-ZM200YKA*, PUZ-ZM250YKA*
*** : , , 1, 2, 3, . . . , 9**

Note: Its serial number is on the nameplate of the product.
Hinweis: Die Seriennummer befindet sich auf dem Kennschild des Produkts.
Remarque : Le numéro de série de l'appareil se trouve sur la plaque du produit.
Opmerking: het serienummer staat op het naamplaatje van het product.
Nota: El número de serie se encuentra en la placa que contiene el nombre del producto.
Nota: il numero di serie si trova sulla targhetta del prodotto.
Σημείωση: Ο σειριακός του αριθμός βρίσκεται στην πινακίδα ονόματος του προϊόντος.
Nota: o número de série encontra-se na placa que contém o nome do produto.
Bemærk: Seriennummeret står på produktets pladeskilt.
Obs: Serienumret finns på produktens namnplåt.
Not: Seri numararı ürünün isim plakasında yer alır.
Примечание: серийный номер указан на паспортной табличке изделия.
Примітка: Серійний номер вказано на паспортній табличці виробу.
Забелешка: Серійният му номер е на табелката на продукта.

Uwaga: Numer seryjny znajduje się na tabliczce znamionowej produktu.
Merk: Seriennummeret befinner seg på navneplaten til produktet.
Huomautus: Sarjanumero on merkitty laitteen arvokilpeen.
Poznámka: Příslušné sériové číslo se nachází na štítku produktu.
Poznámka: Výrobné číslo sa nachádza na typovom štítku výrobku.
Megjegyzés: A sorozatszám a termék adattábláján található.
Opomba: serijska številka je zapisana na tipski ploščici enote.
Notă: Numărul de serie este specificat pe plăcuța indicatoare a produsului.
Märkus: Seerianumber asub toote andmesilidil.
Piezīme: Sērijas numurs ir norādīts uz ierīces datu plāksnītes.
Pastaba: Serijos numeris nurodytas gaminio vardinii duomenų lentelėje.
Napomena: Serijski broj nalazi se na natpisnoj pločici proizvoda.
Napomena: Serijski broj nalazi se na nazivnoj pločici proizvoda.

Directives
Richtlijnen
Directives
Richtlijnen
Directivas
Direttive
Οδηγίες

Directivas
Direktiver
Direktiv
Direktifler
Директиви
Директиви
Директиви

Dyrektywy
Direktiver
Direktivit
Směrnice
Smernice
Írányelvek
Direktive

Directive
Direktivid
Direktivas
Direktivos
Direktive
Direktive

2014/35/EU: Low Voltage Directive
2006/42/EC: Machinery Directive
2014/30/EU: Electromagnetic Compatibility Directive
2009/125/EC: Energy-related Products Directive and Regulation (EU) No. 2016/2281*
2011/65/EU, (EU) 2015/863 and (EU) 2017/2012: RoHS Directive
2014/68/EU: Pressure Equipment Directive

Issued:
JAPAN

7 Sep. 2020

Tomoyuki MIWA
Manager, Quality Assurance Department

<ENGLISH>

English is original. The other languages versions are translation of the original.

▲ CAUTION

- Refrigerant leakage may cause suffocation. Provide ventilation in accordance with EN378-1.
- Be sure to wrap insulation around the piping. Direct contact with the bare piping may result in burns or frostbite.
- Never put batteries in your mouth for any reason to avoid accidental ingestion.
- Battery ingestion may cause choking and/or poisoning.
- Install the unit on a rigid structure to prevent excessive operation sound or vibration.
- The A-weighted sound pressure level is below 70dB.
- This appliance is intended to be used by expert or trained users in shops, in light industry and on farms, or for commercial use by lay persons.

<DEUTSCH>

Das Original ist in Englisch. Die anderen Sprachversionen sind vom Original übersetzt.

▲ VORSICHT

- Wenn Kältemittel austritt, kann dies zu Erstickungen führen. Sorgen Sie in Übereinstimmung mit EN378-1 für Durchlüftung.
- Die Leitungen müssen isoliert werden. Direkter Kontakt mit nicht isolierten Leitungen kann zu Verbrennungen oder Erfrierungen führen.
- Nehmen Sie niemals Batterien in den Mund, um ein versehentliches Verschlucken zu vermeiden.
- Durch das Verschlucken von Batterien kann es zu Erstickungen und/oder Vergiftungen kommen.
- Installieren Sie das Gerät auf einem stabilen Untergrund, um übermäßige Betriebsgeräusche oder -schwingungen zu vermeiden.
- Der A-gewichtete Schallleistungspegel ist niedriger als 70dB.
- Dieses Gerät ist vorgesehen für die Nutzung durch Fachleute oder geschultes Personal in Werkstätten, in der Leichtindustrie und in landwirtschaftlichen Betrieben oder für die kommerzielle Nutzung durch Laien.

<FRANÇAIS>

L'anglais est l'original. Les versions fournies dans d'autres langues sont des traductions de l'original.

▲ PRECAUTION

- Une fuite de réfrigérant peut entraîner une asphyxie. Fournissez une ventilation adéquate en accord avec la norme EN378-1.
- Assurez-vous que la tuyauterie est enveloppée d'isolant. Un contact direct avec la tuyauterie nue peut entraîner des brûlures ou des engelures.
- Ne mettez jamais des piles dans la bouche pour quelque raison que ce soit pour éviter de les avaler par accident.
- Le fait d'ingérer des piles peut entraîner un étouffement et/ou un empoisonnement.
- Installez l'appareil sur une structure rigide pour prévenir un bruit de fonctionnement et une vibration excessifs.
- Le niveau de pression acoustique pondéré est en dessous de 70 dB.
- Cet appareil est conçu pour un utilisateur expert ou les utilisateurs formés en magasin, dans l'industrie légère et dans l'agriculture ou dans le commerce par le profane.

<NEDERLANDS>

Het Engels is het origineel. De andere taalversies zijn vertalingen van het origineel.

▲ VOORZICHTIG

- Het lekken van koelvloeistof kan verstikking veroorzaken. Zorg voor ventilatie in overeenstemming met EN378-1.
- isoleer de leidingen met isolatiemateriaal. Direct contact met de onbedekte leidingen kan leiden tot brandwonden of bevriezing.
- Stop nooit batterijen in uw mond om inslikking te voorkomen.
- Het inslikken van batterijen kan verstikking of vergiftiging veroorzaken.
- Installeer het apparaat op een stabiele structuur om overmatig lawaai of trillingen te voorkomen.
- Het niveau van de geluidsdruk ligt onder 70 dB(A).
- Dit apparaat is bedoeld voor gebruik door ervaren of opgeleide gebruikers in werkplaatsen, in de lichte industrie en op boerderijen, of voor commercieel gebruik door leken.

<ESPAÑOL>

El idioma original del documento es el inglés. Las versiones en los demás idiomas son traducciones del original.

▲ CUIDADO

- Las pérdidas de refrigerante pueden causar asfixia. Se debe proporcionar la ventilación determinada en EN378-1.
- Asegúrese de colocar el aislante alrededor de las tuberías. El contacto directo con la tubería puede ocasionar quemaduras o congelación.
- Para evitar una ingestión accidental, no coloque las pilas en su boca bajo ningún concepto.
- La ingestión de las pilas puede causar asfixia y/o envenenamiento.
- Coloque la unidad en una estructura rígida para evitar que se produzcan sonidos o vibraciones excesivos debidos a su funcionamiento.
- El nivel de presión acústica ponderado A es inferior a 70 dB.
- Este aparato está destinado a su uso por parte de usuarios expertos o capacitados en talleres, industrias ligeras y granjas, o a su uso comercial por parte de personas no expertas.

<ITALIANO>

Il testo originale è redatto in lingua Inglese. Le altre versioni linguistiche rappresentano traduzioni dell'originale.

▲ ATTENZIONE

- Le perdite di refrigerante possono causare asfissia. Prevedere una ventilazione adeguata in conformità con la norma EN378-1.
- Accertarsi di applicare materiale isolante intorno alle tubature. Il contatto diretto con le tubature non schermate può provocare ustioni o congelamento.
- Non introdurre in nessun caso le batterie in bocca onde evitare ingestioni accidentali.
- L'ingestione delle batterie può provocare soffocamento e/o avvelenamento.
- Installare l'unità su una struttura rigida in modo da evitare rumore o vibrazioni eccessivi durante il funzionamento.
- Il livello di pressione del suono ponderato A è inferiore a 70dB.
- Questa apparecchiatura è destinata all'utilizzo da parte di utenti esperti o addestrati in negozi, industria leggera o fattorie oppure a un uso commerciale da parte di persone non esperte.

<ΕΛΛΗΝΙΚΑ>

Η γλώσσα του πρωτοτύπου είναι η αγγλική. Οι εκδόσεις άλλων γλωσσών είναι μεταφράσεις του πρωτοτύπου.

▲ ΠΡΟΣΟΧΗ

- Η διαρροή του ψυκτικού ενδέχεται να προκαλέσει ασφυξία. Φροντίστε για τον εξερισμό σύμφωνα με το πρότυπο EN378-1.
- Φροντίστε να τυλιχτεί με μονωτικό υλικό η σωλήνωση. Η απευθείας επαφή με τη γυμνή σωλήνωση ενδέχεται να προκαλέσει εγκαύματα ή κρυοπαγήματα.
- Μη βάζετε ποτέ τις μπαταρίες στο στόμα σας για κανένα λόγο ώστε να αποφύγετε την κατά λάθος κατάποσή τους.
- Η κατάποση μπαταριών μπορεί να προκαλέσει πνιγμό ή/και δηλητηρίαση.
- Εγκαταστήστε τη μονάδα σε σταθερή κατασκευή ώστε να αποφύγετε τον έντονο ήχο λειτουργίας ή τους κραδασμούς.
- Η Α-σταθμισμένη στάθμη ηχητικής πίεσης είναι κάτω των 70dB.
- Η συσκευή αυτή προορίζεται για χρήση από έμπειρους ή εκπαιδευμένους χρήστες σε καταστήματα, στην ελαφριά βιομηχανία και σε αγροκτήματα, ή για εμπορική χρήση από άτομα τα οποία δεν είναι ειδήμονες.

<PORTUGUÊS>

O idioma original é o inglês. As versões em outros idiomas são traduções do idioma original.

▲ CUIDADO

- A fuga de refrigerante pode causar asfixia. Garanta a ventilação em conformidade com a norma EN378-1.
- Certifique-se de que envolva as tubagens com material de isolamento. O contacto directo com tubagens não isoladas pode resultar em queimaduras ou ulcerações provocadas pelo frio.
- Nunca coloque pilhas na boca, por nenhum motivo, para evitar a ingestão accidental.
- A ingestão de uma pilha pode causar obstrução das vias respiratórias e/ou envenenamento.
- Instale a unidade numa estrutura robusta, de forma a evitar ruídos ou vibrações excessivos durante o funcionamento.
- O nível de pressão sonora ponderado A é inferior a 70 dB.
- Este equipamento destina-se a ser utilizado por especialistas ou utilizadores com formação em lojas, na indústria ligeira e em quintas, ou para utilização comercial por leigos.

<DANSK>

Engelsk er originalen. De andre sprogversioner er oversættelser af originalen.

▲ FORSIGTIG

- Lækage af kølemiddel kan forårsage kvælning. Sørg for udluftning i overensstemmelse med EN378-1.
- Sørg for at pakke rørene ind i isolering. Direkte kontakt med ubeklædte rør kan forårsage forbrændinger eller forfrysninger.
- Batterier må under ingen omstændigheder tages i munden for at forhindre utilsigtet indtagelse.
- Indtagelse af batterier kan forårsage kvælning og/eller forgiftning.
- Installer enheden på en fast struktur for at forhindre for høje driftslyde eller vibrationer.
- Det A-vægtede lydtrykniveau er under 70dB.
- Dette apparat er beregnet til at blive brugt af eksperter eller udlærte brugere i butikker, inden for let industri og på gårde eller til kommerciel anvendelse af lægmænd.

<SVENSKA>

Engelska är originalspråket. De övriga språkversionerna är översättningar av originalet.

▲ FÖRSIKTIGHET

- Köldmedelsläckage kan leda till kvävning. Tillhandahåll ventilation i enlighet med EN378-1.
- Kom ihåg att linda isolering runt rören. Direktkontakt med bara rör kan leda till brännskador eller köldskador.
- Stoppa aldrig batterier i munnen, de kan sväljas av misstag.
- Om ett batteri sväljs kan det leda till kvävning och/eller förgiftning.
- Montera enheten på ett stadigt underlag för att förhindra höga driftljud och vibrationer.
- Den A-vägda ljudtrycksnivån är under 70dB.
- Denna apparat är ämnad för användning av experter eller utbildade användare i affärer, inom lätt industri och på lantbruk, eller för kommersiell användning av lekmän.

<TÜRKÇE>

Aslı İngilizce'dir. Diğer dillerdeki sürümler aslının çevirisidir.

▲ DİKKAT

- Soğutucu kaçağı boğulmaya neden olabilir. EN378-1 uyarınca uygun havalandırma sağlayın.
- Borular etrafına yalıtım yapıldığından emin olun. Borularla doğrudan çıplak elle dokunulması yanıklara veya soğuk yarıklarına neden olabilir.
- Kazara yutlamak için, pilleri kesinlikle hiçbir amaçla ağzınızda tutmayın.
- Pillerin yutulması boğulmaya ve/veya zehirlenmeye yol açabilir.
- Aşırı çalışma seslerini veya titreşimi önlemek için, üniteyi sağlam bir yapı üzerine monte edin.
- A ağırlıklı ses gücü seviyesi 70dB'nin altındadır.
- Bu cihaz atölyelerde, hafif endüstriyel tesislerde ve çiftliklerde uzman veya eğitilmiş kullanıcılar tarafından kullanılmak üzere veya normal kullanıcılar tarafından ticari kullanım için tasarlanmıştır.

<РУССКИЙ>

Языком оригинала является английский. Версии на других языках являются переводом оригинала.

▲ ОСТОРОЖНО

- Утечка хладагента может стать причиной удущья. Обеспечьте вентиляцию в соответствии с EN378-1.
- Обязательно оберните трубы изоляционной обмоткой. Непосредственный контакт с неизолированным трубопроводом может привести к ожогам или обморожению.
- Запрещается класть элементы питания в рот по каким бы то ни было причинам во избежание случайного проглатывания.
- Попадание элемента питания в пищеварительную систему может стать причиной удущья и/или отравления.
- Установивайте устройство на жесткую структуру во избежание чрезмерного шума или чрезмерной вибрации во время работы.
- Уровень звукового давления по шкале A не превышает 70 дБ.
- Данное устройство предназначено для использования специалистами или обученным персоналом в магазинах, на предприятиях легкой промышленности и фермах или для коммерческого применения не-профессионалами.

<УКРАЇНСЬКА>

Переклад оригіналу. Текст іншими мовами є перекладом оригіналу.

▲ ОБЕРЕЖНО

- Виток холодагенту може призвести до удущя. Необхідно забезпечити вентиляцію відповідно до стандарту EN 378-1.
- Труби необхідно обмотати ізоляційним матеріалом. Прямий контакт із непокритою трубою може призвести до опіку або обмороження.
- Забороняється класти елементи живлення в рот із будь-яких причин, оскільки є ризик випадково їх проковтнути.
- Попадання елемента живлення в травну систему може стати причиною задухи та/або отруєння.
- Встановлюйте блок на міцній конструкції, щоб уникнути надмірного рівня звуку роботи або вібрації.
- Рівень амплітудно зваженого акустичного тиску становить нижче 70 дБ.
- Цей прилад призначається для використання спеціалістами або особами, що пройшли відповідне навчання, у крамницях, легкій промисловості та сільськогосподарських підприємствах, а також для комерційного використання неспеціалістами.

<БЪЛГАРСКИ>

Оригиналът е текстът на английски език. Версиите на други езици са преводи на оригинала.

▲ ВНИМАНИЕ

- Изтичането на хладилен агент може да причини задушаване. Осигурете вентилация съобразно с EN378-1.
- Не забравяйте да увиете изолация около тръбите. Директният контакт с оголени тръби може да причини изгаряне или измръзване.
- При никакви обстоятелства не поставяйте батериите в устата си, за да не ги погълнете по невнимание.
- Това може да доведе до задушаване и/или натравяне.
- Монтирайте тялото върху твърда конструкция, за да предотвратите прекомерен шум или вибрации по време на работа.
- А-претегленото ниво на звуково налягане е под 70 dB.
- Този уред е предназначен за използване от експерти или обучени потребители в магазини, в леката промишленост и във ферми, или за търговска употреба от неспециалисти.

<POLSKI>

Językiem oryginalu jest język angielski. Inne wersje językowe stanowią tłumaczenie oryginalu.

▲ UWAGA

- Wyciek czynnika chłodniczego może spowodować uduszenie. Należy zapewnić wentylację zgodnie z normą EN378-1.
- Należy pamiętać, aby owinąć izolację wokół przewodów rurowych. Bezpośredni kontakt z niezabezpieczonymi przewodami rurowymi może doprowadzić do poparzeń lub odmrożeń.
- Nie wolno wkładać baterii do ust z jakiegokolwiek powodu, aby uniknąć przypadkowego połknięcia.
- Połknięcie baterii może spowodować zadławienie i/lub zatrucie.
- Zainstalować urządzenie na sztywnej konstrukcji, aby zapobiec nadmieremu hałasowi i wibracjom.
- Poziom dźwięku A nie przekracza 70 dB.
- W sklepach, w przemyśle lekkiem i w gospodarstwach rolnych urządzenie powinny obsługiwać profesjonalni lub przeszkoleni użytkownicy, a w środowisku handlowym mogą to być osoby nieposiadające fachowej wiedzy.

<NORSK>

Originalspråket er engelsk. De andre språkversjonene er oversettelser av originalen.

▲ FORSIKTIG

- Kjølemiddelkassje kan forårsake kvelling. Sørg for ventilering i samsvar med EN378-1.
- Pass på at isoleringen pakkes godt rundt røret. Direkte kontakt med ukledte rør kan forårsake brannskader eller forfrysninger.
- Aldri plasser batteri i munnen, da dette kan medføre en risiko for at du svelger batteriet ved et uhell.
- Hvis du svelger et batteri, kan du risikere kvelling og/eller forgiftning.
- Installer enheten på en stabil struktur for å forhindre uønsket driftsstøy eller vibrering.
- Det A-vektdet lydtryknivået er under 70 dB.
- Dette apparatet er ment for bruk av eksperter eller faglatte personell i butikker, lettindustri og på gårder, eller for kommersielt bruk av ikke-fagmenn.

<SUOMI>

Englanti on alkuperäinen. Muut kieliversiot ovat alkuperäiskappaleen käännöksiä.

▲ HUOMIO

- Vuotava kylmäaine voi aiheuttaa tukehtumisen. Ilmanvaihdon on oltava EN378-1-standardin mukainen.
- Kääri putken ympärille eristysmateriaalia. Palkiaan putken koskettamisesta voi seurata palotai paleltumavammoja.
- Älä koskaan laita paristoja suuhun, jotta et vahingossa nielaisisi niitä.
- Paristojen nieleminen voi aiheuttaa tukehtumisen ja/tai myrkytyksen.
- Asenna yksikkö tukeviin rakenteisiin, jotta sen käytöstä ei syntyisi ylimääräistä ääntä tai värinää.
- A-painotettu äänenpainetaso on alle 70 dB.
- Laite on tarkoitettu asiantuntijoiden tai laitteelle koulutuksen saaneiden käyttöön kaupossa, pienteollisuudessa ja maatiloilta tai maailikoille kaupalliseen käyttöön.

<ČEŠTINA>

Originál je v angličtině. Ostatní jazykové verze jsou překladem originálu.

▲ POZOR

- Únik chladicího média může způsobit udušení. Zajistěte větrání v souladu s normou EN 378-1.
- Okolo potrubí vždy omotejte izolací. Přímý kontakt s obnaženým potrubím může způsobit popálení nebo omrzliny.
- Nikdy nevkładějte baterie do úst, aby nedošlo k jejich polknutí.
- Polknutí baterie může způsobit zadušení a/nebo otrávu.
- Jednotku nainstalujte na pevnou konstrukci, aby nedocházelo ke vzniku nadměrného provozního hluku a vibrací.
- Hladina akustického tlaku A je nižší než 70 dB.
- Toto zařízení je určeno pro prodejny, lehký průmysl a farmy, kde je musí obsluhovat odborníci a školení uživatelé, a pro komerční použití, kde je mohou obsluhovat laici.

<SLOVENČINA>

Preklad anglického originálu. Všetky jazykové verzie sú preložené z angličtiny.

▲ UPOZORNENIE

- Únik chladiva môže spôsobiť udusenie. Zabezpečte vetranie podľa normy EN 378-1.
- Nezabudnite potrubie obaliť izoláciou. Priamy kontakt s nezabaleným potrubím môže spôsobiť popálenie alebo omrzliny.
- Batérie si nikdy z akéhokoľvek dôvodu nekladte do úst, aby nedošlo k ich náhodnému požitiu.
- Požitie batérií môže vyvolať dusenie a/alebo otrávu.
- Nainštalujte jednotku na pevný konštrukčný prvok, aby ste obmedzili nadmerný prevádzkový hluč a vibrácie.
- Hladina akustického tlaku A je nižšia ako 70 dB.
- Toto zariadenie je určené na používanie odborníkmi alebo zaškolenými používateľmi v komerčných priestoroch, v prostredí ľahkého priemyslu, na farmách, alebo na komerčné použitie bežnými používateľmi.

<MAGYAR>

Az angol változat az eredeti. A többi nyelvi változat az eredeti fordítása.

▲ VIGYÁZAT

- A hűtőközeg szivárgása fulladást okozhat. Gondoskodjon az EN378-1 szabvány előírásai szerinti szellőzéstől.
- Feltétlenül szigetelje körbe a csöveket. A csupasz cső megérintése égési vagy fagyási sérülést okozhat.
- Ne vegyen a szájába elemet semmilyen célból, mert véletlenül lenyelheti!
- A lenyelt elem fulladást és/vagy mérgezést okozhat.
- A készüléket merev szerkezetre szerelje fel, hogy megakadályozza a túlzott üzemi zajt és vibrációt.
- Az A-súlyozott hangnyomásszint 70 dB alatt van.
- A készülék üzletek, a könyvtárak és gazdaságok szakértő vagy képzett felhasználói, valamint laikus felhasználók általi kereskedelmi használatra készült.

<SLOVENŠČINA>

Izvirnik je v angleščini. Druge jezikovne različice so prevodi izvirnika.

▲ POZOR

- Puščanje hladiva lahko povzroči zadušitev. Zagotovite prezračevanje po standardu EN378-1.
- Cevi ovijte z izolacijo. Neposredni stik z golimi cevimi lahko povzroči opekline ali ozeblino.
- Nikoli in iz nobenega razloga ne vstavljajte baterij v usta, da jih po nesreči ne pogoltnete.
- Če baterije pogoltnete, se lahko zadušite in/ali zastrupite.
- Enoto namestite na togo konstrukcijo, da preprečite pretiran zvok ali tresenje med delovanjem.
- A-utežena raven zvočnega tlaka je pod 70 dB.
- Naprava je namenjena za uporabo s strani strokovnih ali ustrezno usposobljenih uporabnikov v trgovinah, lahki industriji in na kmetijah ter za komercialno uporabo s strani nestrokovnih uporabnikov.

<ROMÂNĂ>

Textul original este în limba engleză. Versiunile pentru celelalte limbi sunt traduceri ale originalului.

▲ ATENȚIE

- Scurgerea de agent frigorific poate cauza asfixierea. Asigurați o ventilație corespunzătoare, conform standardului EN378-1.
- Asigurați-vă că înfășurați materialul izolator în jurul conductelor. Contactul direct cu conductele neizolate se poate solda cu arsuri sau degerături.
- Nu introduceți niciodată și pentru niciun motiv bateriile în gură, pentru a evita ingerarea accidentală a acestora.
- Ingerarea bateriilor poate cauza sufocarea și/sau intoxicația.
- Instalați unitatea pe o structură rigidă pentru a preveni producerea unui nivel excesiv de sunete sau vibrații.
- Nivelul de presiune acustică ponderat în A este mai mic de 70 dB.
- Acest aparat este destinat utilizării de către utilizatori specializați sau instruiți în cadrul spațiilor comerciale, spațiilor din cadrul industriei ușoare și al fermelor sau în scopuri comerciale de către nespecialiști.

<EESTI>

Originaaljuhend on ingliskeelne. Muudes keeltes versioonid on originaali tõlked.

▲ ETTEVAATUST!

- Külmaaine leke võib põhjustada lämbumist. Tuulutamise standardi EN378-1 kohaselt.
- Mähkige torude ümber kindlasti isolatsiooni. Vahetu kontakt paljaste torudega võib põhjustada põletusi või külmakahjustusi.
- Hoiduge patareide tahtmatust allaneelamisest, ärge kunagi pange ühelgi põhjusel patareid suhu.
- Patareid allaneelamine võib põhjustada lämbumist ja/või mürgitust.
- Paigaldage seade jäigale struktuurile, et vältida üleäärast tööheli ja vibreerimist.
- A-filtriga helirõhu tase on madalam kui 70 dB.
- Seade on mõeldud kasutamiseks asjatundjatele ja väljaõppe läbinud kasutajatele poodides, kergtööstuses ja taludes ning kommertskasutuseks tavaisikute poolt.

<LATVIŠKI>

Orīģināls ir angļu valodā. Versijas citās valodās ir orīģināla tulkojums.

▲ UZMANĪBU

- Aukstumaģenta noplūdes gadījumā pastāv nosmakšanas risks. Ir jānodrošina standartam EN378-1 atbilstoša ventilācija.
- Aptiniet caurules ar izolējošu materiālu. Pieskaroties neapitām caurulēm, var gūt apdegumus vai apsalējumus.
- Aizliegts ievietot baterijas mutē; pastāv norišanas risks.
- Bateriju norišana var izraisīt aizrīšanas un/vai saindēšanos.
- Uzstādiēt iekārtu uz izturīgas struktūras, lai izvairītos no pārtieku liela darbības trokšņa vai vibrācijas.
- A — izsvartais skaņas spiediena līmenis ir mazāks par 70 dB.
- Šo iekārtu paredzēts lietot speciālistiem vai apmācītiem lietotājiem veikalos, vieglās rūpniecības telpās un lauksaimniecības fermās, kā arī to var lietot nespeciālisti komerciālām vajadzībām.

<LIETUVIŠKAI>

Originalas yra anglų k. Versijos kitomis kalbomis yra originalo vertimas.

▲ ATSARGIAI

- Dėl šaltnešio nuotėkio galima uždušti. Išvėdinkite patalpas pagal EN378-1.
- Būtinai vamzdelius apvyniokite izoliacija. Prisiūtius prie plikų vamzdelių galima nusideginti arba nušalti.
- Siekdami išvengti atsitiktinio prarijimo, niekada nedėkite baterijų į burną.
- Prarijus bateriją galima užspringti ir / arba apsinuodyti.
- Įrenginį sumontuokite ant tvirtos struktūros, kad nesigirdėtų pernelgų didelio veikimo triukšmo ar vibracijos.
- A svertinis garso slėgio lygis nesiekia 70 dB;
- šis prietaisas skirtas naudoti specialistui ar išmokytiems naudotojams dirbtuvėse, lengvojoje pramonėje ar ūkiuose arba komerciniam naudojimui nespecialistams.

<HRVATSKI>

Tekst je izvorno napisan na engleskom jeziku. Tekst na ostalim jezicima predstavlja prijevod izvorno napisanog teksta.

▲ OPREZ

- Čurenje rashladnog sredstva može uzrokovati gušenje. Osigurajte ventilaciju u skladu s normom HR EN378-1.
- Obvezno stavite izolaciju oko položenih cijevi. Izravni doticaj s golim cijevima može dovesti do opekline ili smrzavanja.
- Nikada ne smrvljajte baterije u usta ni zbog kojeg razloga kako biste izbjegli slučajno gutanje.
- Gutanje baterija može prouzročiti gušenje i/ili trovanje.
- Postavite jedinicu na čvrstu površinu kako biste izbjegli prebučnu zvuk tijekom rada ili pojavu vibracija.
- Razina zvučnog tlaka A niža je od 70dB.
- Ovak uređaj mogu upotrebljavati stručnjaci ili osposobljeni korisnici u trgovinama, lakoj industriji i na poljoprivrednim gospodarstvima ili laici u komercijalne svrhe.

<SRPSKI>

Prevod originala. Verzije na drugim jezicima su prevodi originala.

▲ OPREZ

- Čurenje rashladne tečnosti može da dovede do gušenja. Obezbedite ventilaciju u skladu sa EN378-1.
- Obavezno obmotajte izolaciju oko cevi. Direktn kontakt sa golom cevi može izazvati opekotine ili promrzline.
- Nikada nemojte stavljati baterije u usta iz bilo kog razloga, kako bi se sprečilo slučajno gutanje.
- Gutanje baterija može da izazove gušenje i/ili trovanje.
- Ugradite jedinicu na čvrstu strukturu kako biste sprečili previše jak zvuk rada ili vibracije.
- A-ponderisani nivo jačine pritiska zvuka je ispod 70 dB.
- Ovak uređaj je namenjen za upotrebu od strane stručnih ili obučanih korisnika u prodavnicama, u lakoj industriji i na farmama ili za komercijalnu upotrebu od strane nekvalfikovanih liča.

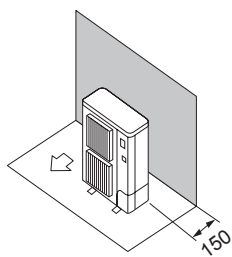

Fig. 2-7

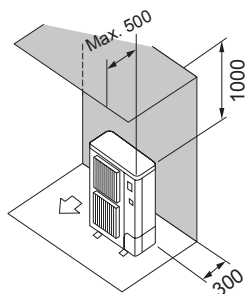

Fig. 2-8

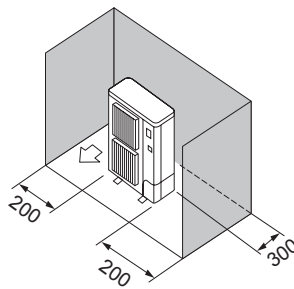

Fig. 2-9

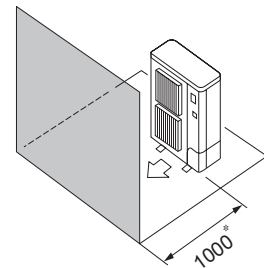

Fig. 2-10

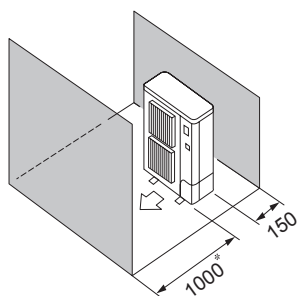

Fig. 2-11

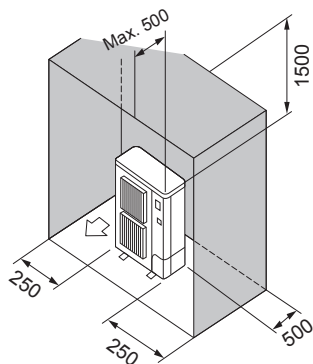

Fig. 2-12

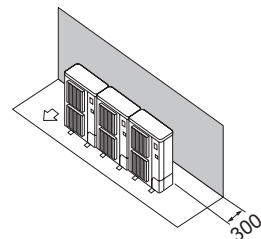

Fig. 2-13

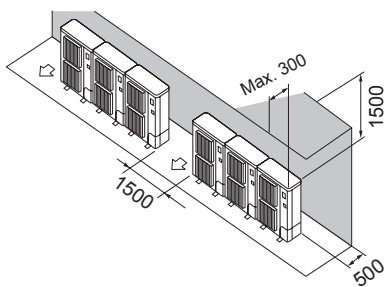

Fig. 2-14

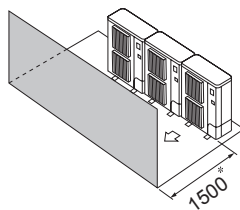

Fig. 2-15

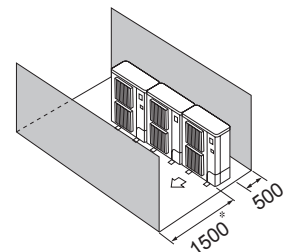

Fig. 2-16

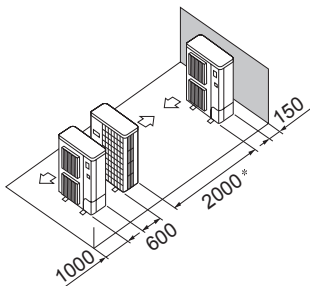

Fig. 2-17

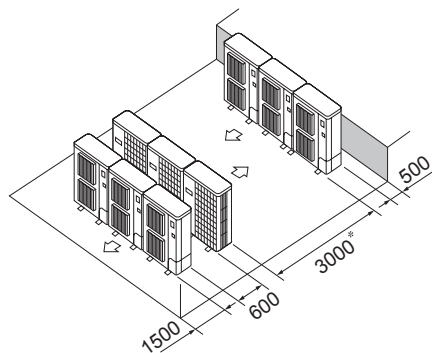

Fig. 2-18

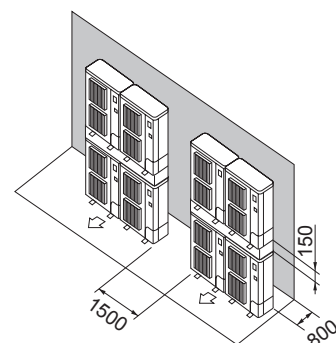

Fig. 2-19

This product is designed and intended for use in the residential,
commercial and light-industrial environment.



mitsubishi **ELECTRIC CORPORATION**

HEAD OFFICE: TOKYO BUILDING, 2-7-3, MARUNOUCHI, CHIYODA-KU, TOKYO 100-8310, JAPAN

BH79D895W01