



## **Split-type Air-Conditioner**

**MXZ-2F33VF3**

**MXZ-2F42VF3**

**MXZ-2F53VF(H)3**

INSTALLATION MANUAL

**English**

## CONTENTS





1. BEFORE INSTALLATION .....	1
2. OUTDOOR UNIT INSTALLATION .....	7
3. FLARING WORK AND PIPE CONNECTION .....	7
4. PURGING PROCEDURES, LEAK TEST, AND TEST RUN .....	9
5. PUMPING DOWN .....	10

## Required Tools for Installation

Phillips screwdriver	Flare tool for R32, R410A
Level	Gauge manifold for R32, R410A
Scale	Vacuum pump for R32, R410A
Utility knife or scissors	Charge hose for R32, R410A
Torque wrench	Pipe cutter with reamer
Wrench (or spanner)	
4 mm hexagonal wrench	

## 1. BEFORE INSTALLATION

## MEANINGS OF SYMBOLS DISPLAYED ON INDOOR UNIT AND/OR OUTDOOR UNIT

	<b>WARNING</b> (Risk of fire)	This unit uses a flammable refrigerant. If refrigerant leaks and comes in contact with fire or heating part, it will create harmful gas and there is risk of fire.
		Read the OPERATING INSTRUCTIONS carefully before operation.
		Service personnel are required to carefully read the OPERATING INSTRUCTIONS and INSTALLATION MANUAL before operation.
		Further information is available in the OPERATING INSTRUCTIONS, INSTALLATION MANUAL, and the like.

## 1-1. THE FOLLOWING SHOULD ALWAYS BE OBSERVED FOR SAFETY

- Be sure to read "THE FOLLOWING SHOULD ALWAYS BE OBSERVED FOR SAFETY" before installing the air conditioner.
- Be sure to observe the warnings and cautions specified here as they include important items related to safety.
- After reading this manual, be sure to keep it together with the OPERATING INSTRUCTIONS for future reference.

**WARNING** (Could lead to death, serious injury, etc.)

- **Do not install the unit by yourself (user).**  
Incomplete installation could cause fire or electric shock, injury due to the unit falling, or leakage of water. Consult the dealer from whom you purchased the unit or a qualified installer.
- **Perform the installation securely referring to the installation manual.**  
Incomplete installation could cause fire, electric shock, injury due to the unit falling, or leakage of water.
- **When installing the unit, use appropriate protective equipment and tools for safety.**  
Failure to do so could cause injury.
- **Install the unit securely in a place which can bear the weight of the unit.**  
If the installation location cannot bear the weight of the unit, the unit could fall causing injury.
- **Electrical work should be performed by a qualified, experienced electrician, according to the installation manual. Be sure to use an exclusive circuit. Do not connect other electrical appliances to the circuit.**  
If the capacity of the power circuit is insufficient or there is incomplete electrical work, it could result in a fire or an electric shock.
- **Do not damage the wires by applying excessive pressure with parts or screws.**  
Damaged wires could cause fire or electric shock.
- **Be sure to cut off the main power in case of setting up the indoor P.C. board or wiring works.**  
Failure to do so could cause electric shock.
- **Use the specified wires to connect the indoor and outdoor units securely and attach the wires firmly to the terminal block connecting sections so the stress of the wires is not applied to the sections. Do not extend the wires, or use intermediate connection.**  
Incomplete connecting and securing could cause fire.
- **Do not install the unit in a place where inflammable gas may leak.**  
If gas leaks and accumulates in the area around the unit, it could cause an explosion.
- **Do not use intermediate connection of the power cord or the extension cord and do not connect many devices to one AC outlet.**  
It could cause a fire or an electric shock due to defective contact, defective insulation, exceeding the permissible current, etc.
- **Be sure to use the parts provided or specified parts for the installation work.**  
The use of defective parts could cause an injury or leakage of water due to a fire, an electric shock, the unit falling, etc.
- **When plugging the power supply plug into the outlet, make sure that there is no dust, clogging, or loose parts in both the outlet and the plug. Make sure that the power supply plug is pushed completely into the outlet.**  
If there is dust, clogging, or loose parts on the power supply plug or the outlet, it could cause electric shock or fire. If loose parts are found on the power supply plug, replace it.
- **Attach the electrical cover to the indoor unit and the service panel to the outdoor unit securely.**  
If the electrical cover of the indoor unit and/or the service panel of the outdoor unit are not attached securely, it could result in a fire or an electric shock due to dust, water, etc.
- **When installing, relocating, or servicing the unit, make sure that no substance other than the specified refrigerant (R32) enters the refrigerant circuit.**  
Any presence of foreign substance such as air can cause abnormal pressure rise and may result in explosion or injury. The use of any refrigerant other than that specified for the system will cause mechanical failure, system malfunction, or unit breakdown. In the worst case, this could lead to a serious impediment to securing product safety.
- **Do not discharge the refrigerant into the atmosphere. If refrigerant leaks during installation, ventilate the room. Check that the refrigerant does not leak after installation has been completed.**  
If refrigerant leaks and comes in contact with fire or heating part of such a fan heater, kerosene heater, or cooking stove, it will create harmful gas. Provide ventilation in accordance with EN378-1.
- **Use appropriate tools and piping materials for installation.**  
The pressure of R32 is 1.6 times more than R22. Not using appropriate tools or materials and incomplete installation could cause the pipes to burst or injury.
- **When pumping down the refrigerant, stop the compressor before disconnecting the refrigerant pipes.**  
If the refrigerant pipes are disconnected while the compressor is running and the stop valve is open, air could be drawn in and the pressure in the refrigeration cycle could become abnormally high. This could cause the pipes to burst or injury.
- **When installing the unit, securely connect the refrigerant pipes before starting the compressor.**  
If the compressor is started before the refrigerant pipes are connected and when the stop valve is open, air could be drawn in and the pressure in the refrigeration cycle could become abnormally high. This could cause the pipes to burst or injury.
- **Fasten a flare nut with a torque wrench as specified in this manual.**  
If fastened too tight, a flare nut may break after a long period and cause refrigerant leakage.
- **The unit shall be installed in accordance with national wiring regulations.**
- **Earth the unit correctly.**  
Do not connect the earth to a gas pipe, water pipe, lightning rod or telephone earth. Defective earthing could cause electric shock.
- **Be sure to install an earth leakage breaker.**  
Failure to install an earth leakage breaker may result in electric shock or fire.
- **When using a gas burner or other flame-producing equipment, completely remove all of the refrigerant from the air conditioner and ensure that the area is well-ventilated.**  
If the refrigerant leaks and comes in contact with fire or heating part, it will create harmful gas and there is risk of fire.
- **Do not use means to accelerate the defrosting process or to clean, other than those recommended by the manufacturer.**
- **The appliance shall be stored in a room without continuously operating ignition sources (for example: open flames, an operating gas appliance or an operating electric heater).**
- **Do not pierce or burn.**
- **Be aware that refrigerants may not contain an odour.**
- **Pipe-work shall be protected from physical damage.**
- **The installation of pipe-work shall be kept to a minimum.**
- **Compliance with national gas regulations shall be observed.**
- **Keep any required ventilation openings clear of obstruction.**
- **Do not use low temperature solder alloy in case of brazing the refrigerant pipes.**
- **The appliance shall be stored in a well-ventilated area where the room size corresponds to the room area as specified for operation.**
- **Service shall be performed only as recommended by the manufacturer.**
- **Do not alter the unit. It may cause fire, electric shock, injury or water leakage.**

This manual only describes the installation of outdoor unit.  
When installing the indoor unit, refer to the installation manual of indoor unit.

<b>⚠ CAUTION</b> (Could lead to serious injury in particular environments when operated incorrectly.)	
<ul style="list-style-type: none"> <li>■ <b>Install an earth leakage breaker depending on the installation place.</b> If an earth leakage breaker is not installed, it could cause electric shock.</li> <li>■ <b>Perform the drainage/piping work securely according to the installation manual.</b> If there is defect in the drainage/piping work, water could drop from the unit, soaking and damaging household goods.</li> <li>■ <b>Do not touch the air inlet or the aluminum fins of the outdoor unit.</b> This could cause injury.</li> </ul>	<ul style="list-style-type: none"> <li>■ <b>Do not install the outdoor unit where small animals may live.</b> If small animals enter and touch the electric parts inside the unit, it could cause a malfunction, smoke emission, or fire. Also, advise user to keep the area around the unit clean.</li> <li>■ <b>Do not operate the air conditioner during interior construction and finishing work, or while waxing the floor.</b> Before operating the air conditioner, ventilate the room well after such work is performed. Otherwise, it may cause volatile elements to adhere inside the air conditioner, resulting in water leakage or scattering of dew.</li> </ul>

## 1-2. SPECIFICATIONS

Model	Power supply *1			Wire specifications *2		Pipe length and height difference *3, *4, *5, *6, *7, *8			Outdoor Noise level			
	Rated Voltage	Frequency	Breaker capacity	Power supply	Indoor/outdoor connecting wire	Max. pipe length per indoor unit / for multi-system	Max. height difference *9	Max. no. of bends per indoor unit / for multi-system	Cooling	Heating		
MXZ-2F33VF3	220-230-240 V	50 Hz	15 A	3-core 1.0 mm <sup>2</sup>	4-core 1.0/1.5 mm <sup>2</sup>	15 m / 20 m	10 m	15 / 20	49 dB (A)	50 dB (A)		
MXZ-2F42VF3				3-core 2.0 mm <sup>2</sup>		20 m / 30 m			15 m	20 / 30	44 dB (A)	50 dB (A)
MXZ-2F53VF(H)3									46 dB (A)	51 dB (A)		

Model	Maximum amount of refrigerant charge	Factory-charged refrigerant amount
MXZ-2F33VF3	0.8 kg	0.8 kg
MXZ-2F42VF3	1.0 kg	1.0 kg
MXZ-2F53VF(H)3		

- \*1 Connect to the power switch which has a gap of 3 mm or more when open to interrupt the source power phase. (When the power switch is shut off, it must interrupt all phases.)
- \*2 Use wires in conformity with design 60245 IEC 57. Use the indoor/outdoor connecting wire in conformity with the wire specifications specified in the installation manual of the indoor unit.
- \*3 Never use pipes with thickness less than specified. The pressure resistance will be insufficient.
- \*4 Use a copper pipe or a copper-alloy seamless pipe.
- \*5 Be careful not to crush or bend the pipe during pipe bending.
- \*6 Refrigerant pipe bending radius must be 100 mm or more.
- \*7 Insulation material : Heat resisting foam plastic 0.045 specific gravity
- \*8 Be sure to use the insulation of specified thickness. Excessive thickness may cause incorrect installation of the indoor unit and insufficient thickness may cause dew drippage.
- \*9 If the outdoor unit is installed higher than the indoor unit, max. height difference is reduced to 10 m.

## 1-3. SELECTING OPTIONAL DIFFERENT-DIAMETER JOINTS

If the diameter of connection pipe does not match the port size of outdoor unit, use optional different-diameter joints according to the following table.

(Unit: mm (inch))

Port size of outdoor unit		Optional different-diameter joints (port size of outdoor unit → diameter of connection pipe)
MXZ-2F	Liquid / Gas	9.52 (3/8) → 12.7 (1/2) : MAC-A454JP-E Refer to the installation manual of indoor unit for the diameter of connection pipe of indoor unit.
A, B UNIT	6.35 (1/4) / 9.52 (3/8)	

## 1-4. SELECTING THE INSTALLATION LOCATION

- Where it is not exposed to strong wind.
- Where airflow is good and dustless.
- Where rain or direct sunshine can be avoided as much as possible.
- Where neighbours are not annoyed by operation sound or hot air.
- Where rigid wall or support is available to prevent the increase of operation sound or vibration.
- Where there is no risk of combustible gas leakage.
- When installing the unit, be sure to secure the unit legs.
- Where it is at least 3 m away from the antenna of TV set or radio. Operation of the air conditioner may interfere with radio or TV reception in areas where reception is weak. An amplifier may be required for the affected device.
- Install the unit horizontally.
- Please install it in an area not affected by snowfall or blowing snow. In areas with heavy snow, please install a canopy, a pedestal and/or some baffle boards.

### Note:

It is advisable to make a piping loop near outdoor unit so as to reduce vibration transmitted from there.

### Note:

When operating the air conditioner in low outside temperature, be sure to follow the instructions described below.

- Never install the outdoor unit in a place where its air inlet/outlet side may be exposed directly to wind.
- To prevent exposure to wind, install the outdoor unit with its air inlet side facing the wall.
- To prevent exposure to wind, it is recommended to install a baffle board on the air outlet side of the outdoor unit.

Avoid the following places for installation where air conditioner trouble is liable to occur.

- Where flammable gas could leak.
- Where there is much machine oil.
- Where oil is splashed or where the area is filled with oily smoke (such as cooking areas and factories, in which the properties of plastic could be changed and damaged).
- Salty places such as the seaside.
- Where sulfide gas is generated such as a hot spring.
- Where there is high-frequency or wireless equipment.
- Where there is emission of high levels of VOCs, including phthalate compounds, formaldehyde, etc., which may cause chemical cracking.
- The appliance shall be stored so as to prevent mechanical damage from occurring.

en

- R32 is heavier than air—as well as other refrigerants—so tends to accumulate at the base (in the vicinity of the floor). If R32 accumulates around base, it may reach a flammable concentration in case room is small. To avoid ignition, maintaining a safe work environment is required by ensuring appropriate ventilation. If a refrigerant leak is confirmed in a room or an area where there is insufficient ventilation, refrain from using of flames until the work environment can be improved by ensuring appropriate ventilation.
- Refrigerant pipes connection shall be accessible for maintenance purposes.
- Install outdoor units in a place where at least one of the four sides is open, and in a sufficiently large space without depressions.

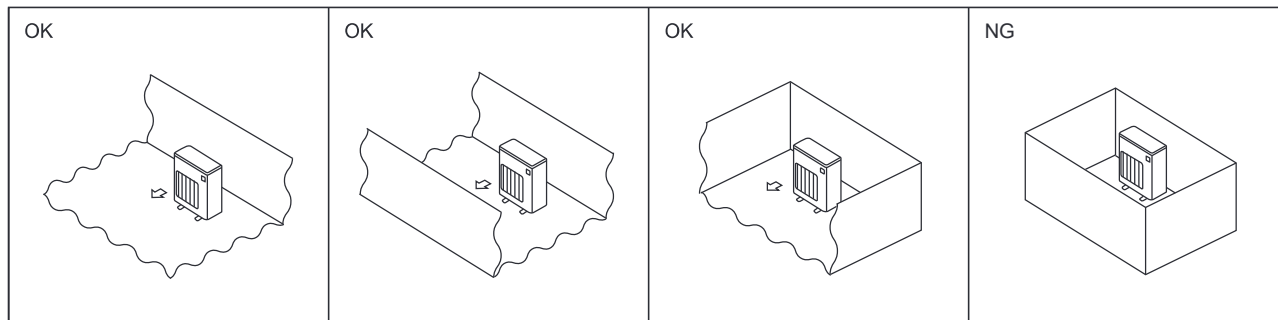

en

### 1-4-1. Minimum installation area for Outdoor units

If you unavoidably install a unit in a space where all four sides are blocked or there are depressions, confirm that one of these situations (A, B or C) is satisfied.

**Note: These countermeasures are for keeping safety not for specification guarantee.**

A) Secure sufficient installation space (minimum installation area  $A_{min}$ ).

Install in a space with an installation area of  $A_{min}$  or more, corresponding to refrigerant quantity  $M$  (factory-charged refrigerant + locally added refrigerant).

M [kg]	$A_{min}$ [m <sup>2</sup> ]
1.0	12
1.5	17
2.0	23
2.5	28
3.0	34
3.5	39
4.0	45
4.5	50
5.0	56
5.5	62
6.0	67
6.5	73
7.0	78
7.5	84

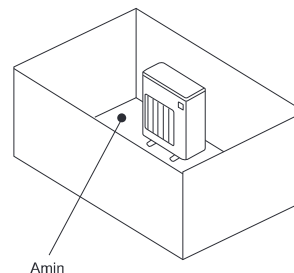

B) Install in a space with a depression height of  $\leq 0.125$  [m].

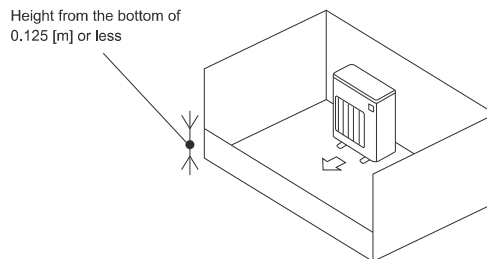
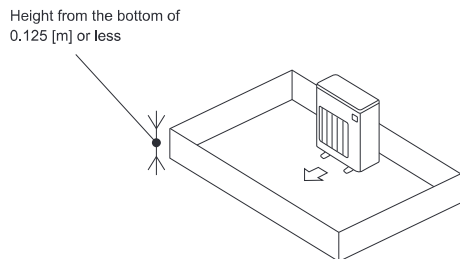

C) Create an appropriate ventilation open area.

Make sure that the width of the open area is 0.9 [m] or more and the height of the open area is 0.15 [m] or more.

However, the height from the bottom of the installation space to the bottom edge of the open area should be 0.125 [m] or less.

Open area should be 75% or more opening.

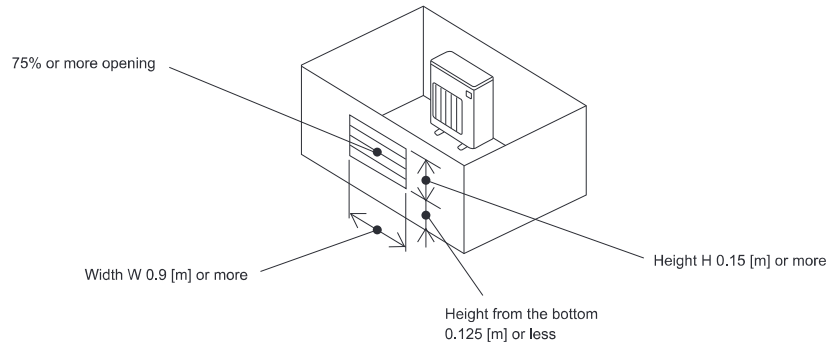

### 1-4-2. Minimum installation area for Indoor units

Install in a room with a floor area of  $A_{min}$  or more, corresponding to refrigerant quantity  $M$  (factory-charged refrigerant + locally added refrigerant).

Install the indoor unit so that the height from the floor to the bottom of the indoor unit is  $h_0$ ;

for wall mounted: 1.8 m or more;

for ceiling suspended, cassette and ceiling concealed: 2.2 m or more;

for floor standing : refer to indoor unit Installation manual.

There are restrictions in installation height for each model, so read the installation manual for the particular unit.

Case 1: for wall mounted, ceiling suspended, cassette and concealed

M [kg]	$A_{min}$ [m <sup>2</sup> ]
1.0	3
1.5	4.5
2.0	6
2.5	7.5
3.0	9
3.5	12
4.0	15.5
4.5	20
5.0	24
5.5	29
6.0	35
6.5	41
7.0	47
7.5	54

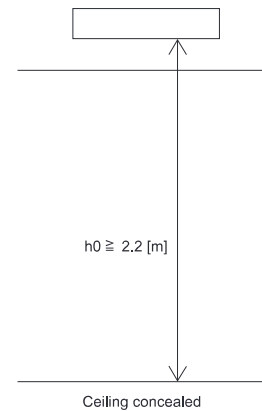
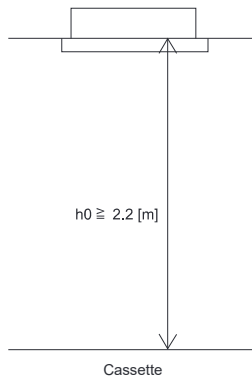
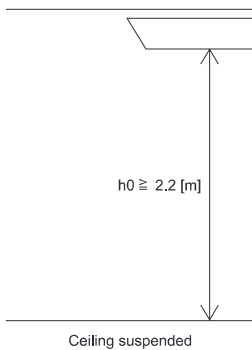
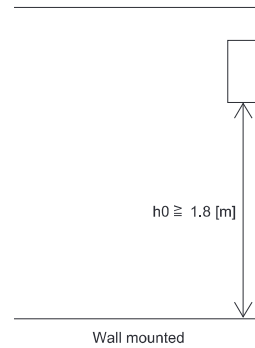

Only for MFZ

M [kg]	Amin [m <sup>2</sup> ]
1.00	No requirements
1.10	
1.20	
1.30	
1.40	
1.50	
1.60	
1.70	
1.80	
1.84	
1.90	3.63
2.00	3.75
2.10	3.95
2.20	4.15
2.30	4.34
2.40	4.54
2.40	4.74

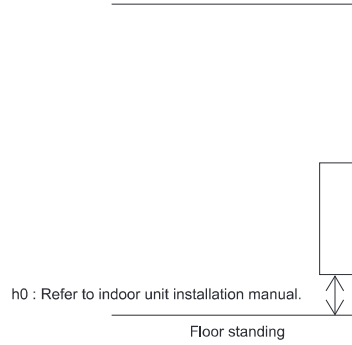

en

## 1-5. INSTALLATION DIAGRAM

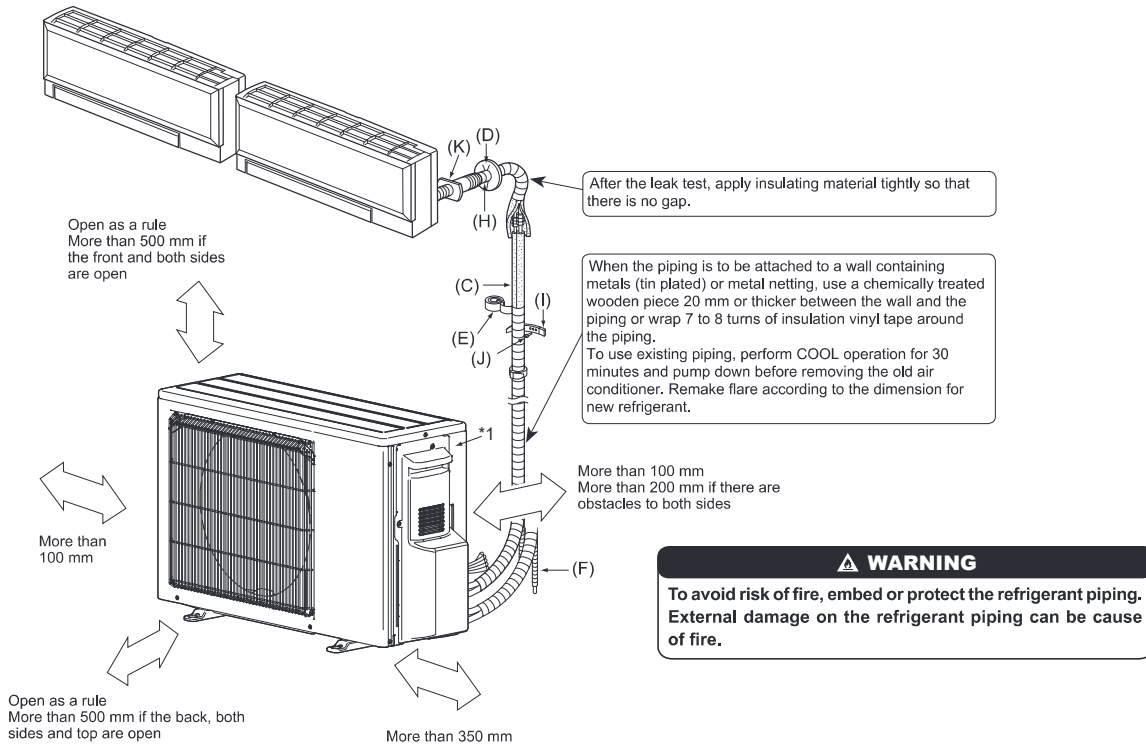

\*1 The manufacturing year and month is indicated on the spec name plate.

### ACCESSORIES

Check the following parts before installation.

(1) Drain socket*2	1
--------------------	---

### PARTS TO BE PROVIDED AT YOUR SITE

(A) Power supply cord*3	1
(B) Indoor/outdoor unit connecting wire*3	1
(C) Extension pipe	1
(D) Wall hole cover	1
(E) Piping tape	1
(F) Extension drain hose (or soft PVC hose, 15 mm inner diameter or hard PVC pipe VP16)	1
(G) Refrigeration oil	Little amount
(H) Putty	1
(I) Pipe fixing band	2 to 7
(J) Fixing screw for (I)	2 to 7
(K) Wall hole sleeve	1
(L) Soft PVC hose, 15 mm inner diameter or hard PVC pipe VP16 for drain socket (1)	1

#### Note:

\*2 2F53V/FH3 is not provided with the drain socket.

\*3 Place indoor/outdoor unit connecting wire (B) and power supply cord (A) at  
least 1 m away from the TV antenna wire.

The "Q'ty" for (B) to (K) in the above table is quantity to be used per indoor unit.

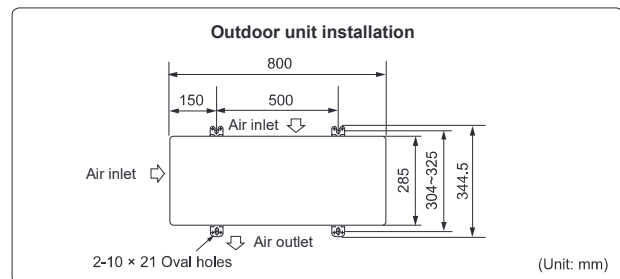

Units should be installed by licensed contractor according to local code  
requirements.

## 1-6. DRAIN PIPING FOR OUTDOOR UNIT

Please perform the drain piping work only when draining from one place.

- 1) Provide drain piping before indoor and outdoor piping connection.
- 2) Connect the soft PVC hose (L) I.D. 15 mm as shown in the illustration.
- 3) Make sure to provide drain piping with a downhill grade for easy drain flow.

#### Note:

Install the unit horizontally.

Do not use the drain socket (1) in the cold regions. Drain may freeze and it  
makes the fan stop.

The outdoor unit produces condensate during the heating operation. Select the  
installation place to ensure to prevent the outdoor unit and/or the grounds from  
being wet by drain water or damaged by frozen drain water.

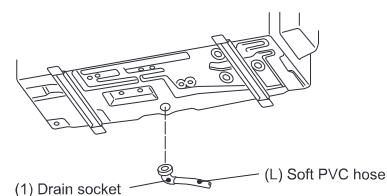

## 2. OUTDOOR UNIT INSTALLATION

### 2-1. CONNECTING WIRES FOR OUTDOOR UNIT

- 1) Remove the service panel.
  - 2) Loosen terminal screw, and connect indoor/outdoor unit connecting wire (B) from the indoor unit correctly on the terminal block. Be careful not to make mis-wiring. Fix the wire to the terminal block securely so that no part of its core is appeared, and no external force is conveyed to the connecting section of the terminal block.
  - 3) Firmly tighten the terminal screws to prevent them from loosening. After tightening, pull the wires lightly to confirm that they do not move.
  - 4) Perform 2) and 3) for each indoor unit.
  - 5) Connect power supply cord (A).
  - 6) Fix indoor/outdoor unit connecting wire (B) and power supply cord (A) with the cable clamps.
  - 7) Close the service panel securely. Make sure that 3-3. PIPE CONNECTION is completed.
- After making connections between both power supply cord (A) and indoor/outdoor unit connecting wire (B), be sure to fix both cable and wire with cable clamps.

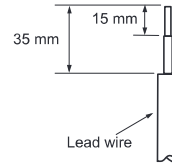
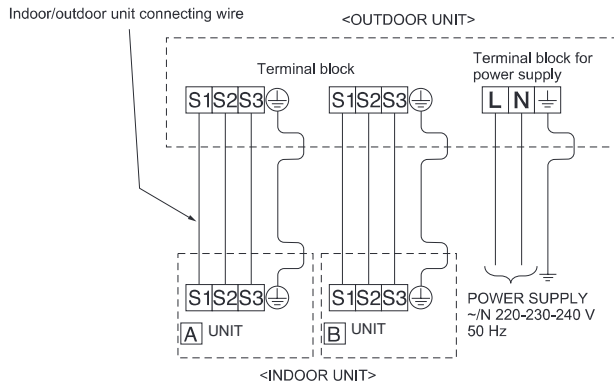
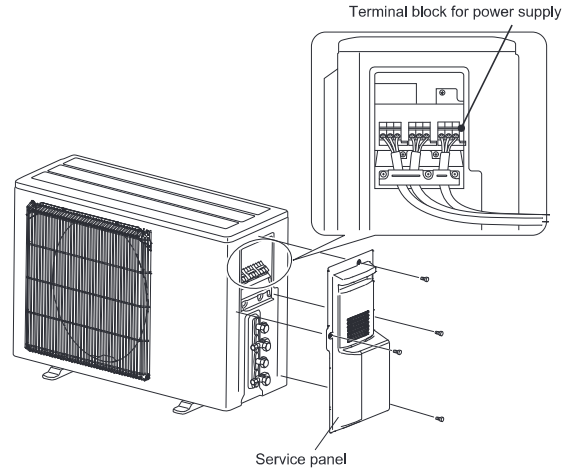

- Be sure to attach each screw to its correspondent terminal when securing the cord and/or the wire to the terminal block.
- Make earth wire a little longer than others. (More than 35 mm)
- For future servicing, give extra length to the connecting wires.

## 3. FLARING WORK AND PIPE CONNECTION

### 3-1. PRECAUTIONS FOR DEVICES THAT USE R32 REFRIGERANT

- Use ester oil, ether oil, alkylbenzene oil (small amount) as the refrigeration oil applied to the flared sections.
  - Use C1220 copper phosphorus, for copper and copper alloy seamless pipes, to connect the refrigerant pipes. Use refrigerant pipes with the thicknesses specified in the table to the below. Make sure the insides of the pipes are clean and do not contain any harmful contaminants such as sulfuric compounds, oxidants, debris, or dust.
- Always apply no-oxidation brazing when brazing the pipes, otherwise, the compressor will be damaged.

#### ⚠ WARNING:

When installing or relocating, or servicing the air conditioner, use only the specified refrigerant (R32) to charge the refrigerant lines. Do not mix it with any other refrigerant and do not allow air to remain in the lines.

If air is mixed with the refrigerant, then it can be the cause of abnormal high pressure in the refrigerant line, and may result in an explosion and other hazards.

The use of any refrigerant other than that specified for the system will cause mechanical failure or system malfunction or unit breakdown. In the worst case, this could lead to a serious impediment to securing product safety.

Pipe size (mm)	ø6.35	ø9.52	ø12.7	ø15.88	ø19.05	ø22.2	ø25.4	ø28.58
Thickness (mm)	0.8	0.8	0.8	1.0	1.0	1.0	1.0	1.0

- Do not use pipes thinner than those specified above.
- Use 1/2 H or H pipes if the diameter is 19.05 mm or larger.
- Be sure to have appropriate ventilation in order to prevent ignition. Furthermore, be sure to carry out fire prevention measures that there are no dangerous or flammable objects in the surrounding area.



### 3-2. FLARING WORK

- 1) Cut the copper pipe correctly with pipe cutter. (Fig. 1, 2)
- 2) Completely remove all burrs from the cut cross section of pipe. (Fig. 3)
  - Aim the copper pipe downward while removing burrs to prevent burrs from dropping in the pipe.
- 3) Remove flare nuts attached to indoor and outdoor units, then put them on pipe having completed burr removal. (Not possible to put them on after flaring work.)
- 4) Flaring work (Fig. 4, 5). Firmly hold copper pipe in the dimension shown in the table. Select A mm from the table according to the tool selected.
- 5) Check
  - Compare the flared work with Fig. 6.
  - If flare is noted to be defective, cut off the flared section and do flaring work again.

Pipe diameter (mm)	Nut (mm)	A (mm)			Tightening torque	
		Clutch type tool for R32, R410A	Clutch type tool for R22	Wing nut type tool for R22	N·m	kgf·cm
ø6.35 (1/4")	17	0 to 0.5	1.0 to 1.5	1.5 to 2.0	13.7 to 17.7	140 to 180
ø9.52 (3/8")	22				34.3 to 41.2	350 to 420
ø12.7 (1/2")	26			2.0 to 2.5	49.0 to 56.4	500 to 575
ø15.88 (5/8")	29				73.5 to 78.4	750 to 800

### 3-3. PIPE CONNECTION

- The connected pipe size differs depending the models and the capacities of indoor units.

Indoor unit capacity		15 ~ 42	50
Liquid pipe size		ø6.35	ø6.35
Gas pipe size	Indoor unit: MSZ	ø9.52	ø9.52 *1
	Indoor unit: other	ø9.52	ø12.7

\*1 Use a joint pipe if the connection of the indoor unit differs.

- Use tightening torque table above as a guideline for indoor unit side union joint section, and tighten using two wrenches. Excessive tightening damages the flare section.
- 1) Apply a thin coat of refrigeration oil (G) to the flared ends of the pipes and the pipe connections of the outdoor unit.
  - 2) Align the center of the pipe with that of the pipe connections of the outdoor unit, then hand tighten the flare nut 3 to 4 turns.
  - 3) Tighten the flare nut with a torque wrench as specified in the table.
    - Over-tightening may cause damage to the flare nut, resulting in refrigerant leakage.
    - Be sure to wrap insulation around the piping. Direct contact with the bare piping may result in burns or frostbite.

### 3-4. INSULATION AND TAPING

- 1) Cover piping joints with pipe cover.
- 2) For outdoor unit side, surely insulate every piping including valves.
- 3) Using piping tape (E), apply taping starting from the entry of outdoor unit.
  - Stop the end of piping tape (E) with tape (with adhesive agent attached).
  - When piping have to be arranged through above ceiling, closet or where the temperature and humidity are high, wind additional commercially sold insulation to prevent condensation.

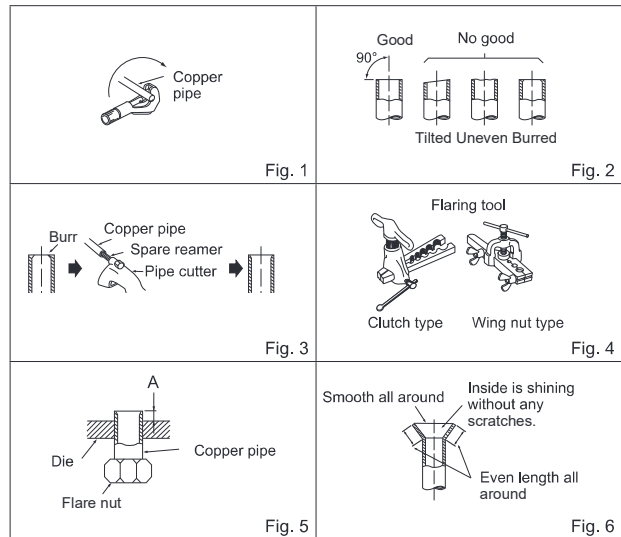

#### ⚠ WARNING

When installing the unit, securely connect the refrigerant pipes before starting the compressor.

#### ⚠ CAUTION

When there are the ports which are not used, make sure their nuts are tightened securely.

## 4. PURGING PROCEDURES, LEAK TEST, AND TEST RUN

### 4-1. PURGING PROCEDURES AND LEAK TEST

- 1) Remove service port cap of stop valve on the side of the outdoor unit gas pipe. (The stop valves are fully closed and covered in caps in their initial state.)
- 2) Connect gauge manifold valve and vacuum pump to service port of stop valve on the gas pipe side of the outdoor unit.
- 3) Run the vacuum pump. (Vacuumize for more than 15 minutes.)
- 4) Check the vacuum with gauge manifold valve, then close gauge manifold valve, and stop the vacuum pump.
- 5) Leave as it is for one or two minutes. Make sure the pointer of gauge manifold valve remains in the same position. Confirm that pressure gauge shows -0.101 MPa [Gauge] (-760 mmHg).
- 6) Remove gauge manifold valve quickly from service port of stop valve.
- 7) Fully open all stop valves on the gas pipe and the liquid pipe. Operating without fully opening lowers the performance and this causes trouble.
- 8) Refer to 1-2., and charge the prescribed amount of refrigerant if needed. Be sure to charge slowly with liquid refrigerant.
- 9) Tighten cap of service port to obtain the initial status.
- 10) Leak test

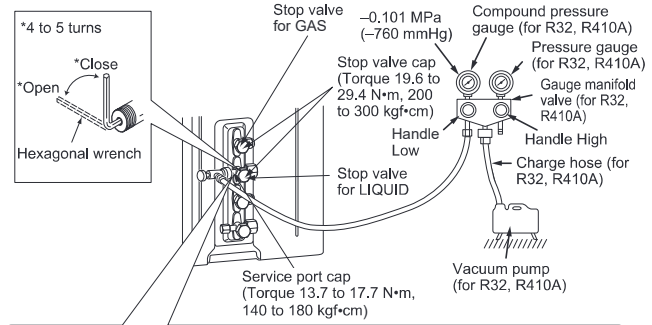

**WARNING**  
To avoid risk of fire, make sure that there are no flammable hazards or ignition risks before opening the stop valves.

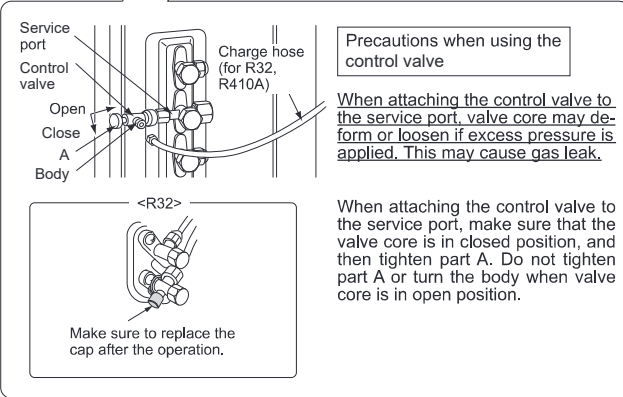

### 4-2. GAS CHARGE

Perform gas charge to unit.

- 1) Connect gas cylinder to the service port of stop valve.
- 2) Perform air purge of the pipe (or hose) coming from refrigerant gas cylinder.
- 3) Replenish specified amount of the refrigerant, while operating the air conditioner for cooling.

#### Note:

In case of adding refrigerant, comply with the quantity specified for the refrigerating cycle.

#### CAUTION:

When charging the refrigerant system with additional refrigerant, be sure to use liquid refrigerant. Charge the liquid refrigerant slowly, otherwise the compressor will be locked.

To maintain the high pressure of the gas cylinder, warm the gas cylinder with warm water (under 40°C) during cold season. But never use naked fire or steam.

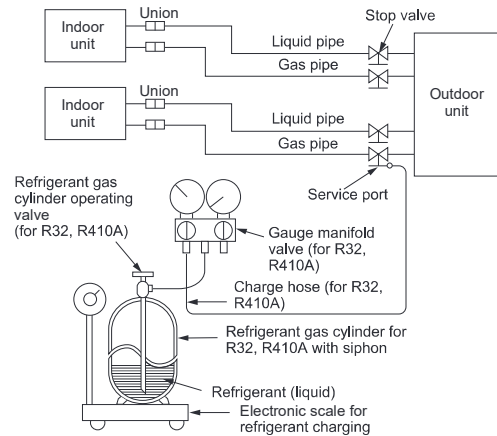

Make sure to indicate the followings with ineffaceable ink on the designated label / spec label.

- (1) Precharged refrigerant amount – see spec label
- (2) On site additionally charged amount
- (3) Total refrigerant amount (1)+(2)
- (4) (5) (6) CO<sub>2</sub> equivalent

	I (kg)	II (t)
①	(1)	(4)
②	(2)	(5)
③	(3)	(6)

$$(4) = (1) \times 675/1000$$

$$(5) = (2) \times 675/1000$$

$$(6) = (3) \times 675/1000$$

**Contains fluorinated greenhouse gases**

- ① Factory charge (Refer to SPEC LABEL)
- ② Additional charge
- ③ Total charge (①+②)

I Weight  
II CO<sub>2</sub> equivalent  
(I) × GWP/1000

**R32 (GWP:675)**

	I (kg)	II (t)
①		
②		
③		

\*1. This information is based on Regulation (EU) No.517/2014.

\*2. According to IPCC 3rd edition, GWP is defined as 550.

### 4-3. LOCKING THE OPERATION MODE OF THE AIR CONDITIONER (COOL, DRY, HEAT)

- Description of the function:  
With this function, once the operation mode is locked to either COOL/DRY mode or HEAT mode, the air conditioner operates in that mode only.
- \* Changing the setting is required to activate this function. Please explain about this function to your customers and ask them whether they want to use it.

#### [How to lock the operation mode]

- 1) Be sure to turn off the main power for the air conditioner before making the setting.
- 2) Set the "1" of SW1 on the outdoor display board to ON to enable this function.
- 3) To lock the operation mode in COOL/DRY mode, set the "2" of SW1 on the outdoor display board to OFF. To lock the operation in HEAT mode, set the same switch to ON.
- 4) Turn on the main power for the air conditioner.

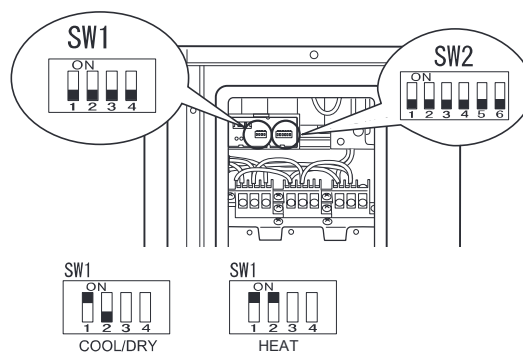

### 4-4. LOWERING THE OPERATION NOISE OF THE OUTDOOR UNIT

- Description of the function:  
With this function, the operating noise of the outdoor unit can be lowered by reducing the operation load, for example, during nighttime in COOL mode. However, please note that the cooling and heating capacity may lower if this function is activated.
- \* Changing the setting is required to activate this function. Please explain about this function to your customers and ask them whether they want to use it.

#### [How to lower the operating noise]

- 1) Be sure to turn off the main power for the air conditioner before making the setting.
- 2) Set the "3" of SW1 on the outdoor display board to ON to enable this function.
- 3) Turn on the main power for the air conditioner.



### 4-5. TEST RUN

- Test runs of the indoor units should be performed individually. See the installation manual coming with the indoor unit, and make sure all the units operate properly.
- If the test run with all the units is performed at once, possible erroneous connections of the refrigerant pipes and the indoor/outdoor unit connecting wires cannot be detected. Thus, be sure to perform the test run one by one.

Make sure that the following is done.

- Power is supplied to the unit.
- Stop valves are open.

#### About the restart protective mechanism

Once the compressor stops, the restart preventive device operates so the compressor will not operate for 3 minutes to protect the air conditioner.

### 4-6. EXPLANATION TO THE USER

- Using the OPERATING INSTRUCTIONS, explain to the user how to use the air conditioner (how to use the remote controller, how to remove the air filters, how to remove or put the remote controller in the remote controller holder, how to clean, precautions for operation, etc.).
- Recommend the user to read the OPERATING INSTRUCTIONS carefully.

## 5. PUMPING DOWN

When relocating or disposing of the air conditioner, pump down the system following the procedure below so that no refrigerant is released into the atmosphere.

- 1) Turn off the breaker.
- 2) Connect the gauge manifold valve to the service port of the stop valve on the gas pipe side of the outdoor unit.
- 3) Fully close the stop valve on the liquid pipe side of the outdoor unit.
- 4) Turn on the breaker.
- 5) Start the emergency COOL operation on all the indoor units.
- 6) When the pressure gauge shows 0.05 to 0 MPa [Gauge] (approx. 0.5 to 0 kgf/cm<sup>2</sup>), fully close the stop valve on the gas pipe side of the outdoor unit and stop the operation. (Refer to the indoor unit installation manual about the method for stopping the operation.)
  - \* If too much refrigerant has been added to the air conditioner system, the pressure may not drop to 0.05 MPa [Gauge] (approx. 0.5 kgf/cm<sup>2</sup>), or the protection function may operate due to the pressure increase in the high-pressure refrigerant circuit. If this occurs, use a refrigerant collecting device to collect all of the refrigerant in the system, and then recharge the system with the correct amount of refrigerant after the indoor and outdoor units have been relocated.
- 7) Turn off the breaker. Remove the pressure gauge and the refrigerant piping.

#### **⚠ WARNING**

**When pumping down the refrigerant, stop the compressor before disconnecting the refrigerant pipes. The compressor may burst and cause injury if any foreign substance, such as air, enters the pipes.**

EC DECLARATION OF CONFORMITY  
EG-KONFORMITÄTSERKÄRÄY  
DECLARATION DE CONFORMITÉ CE  
EG-CONFORMITEITSVERKLARING  
DECLARACIÓN DE CONFORMIDAD CE  
DICHIARAZIONE DI CONFORMITÀ CE  
ΔΗΛΩΣΗ ΠΙΣΤΟΤΗΤΑΣ ΕΚ  
DECLARAÇÃO DE CONFORMIDADE CE  
EU-OVERENSSTEMMELSE/ERKLÄRUNG

EG-DEKLARATION OM ÖVERENSSTÄMMELSE  
EC UYGUNLUK BEYANI  
ЕС ДЕКЛАРАЦИЯ ЗА СЪОТВЕТСТВИЕ  
DEKLARACJA ZGODNOŚCI WE  
CE-ERKLÄRUNG OM SAMSVAR  
EY-VAATIMUSTENMUKAISUUSVAKUUTUS  
ES PROHLÁŠENÍ O SHODĚ  
VYHLÁSENIE O ZHODE ES  
EK MEGFELELŐSÉGI NYILATKOZAT

IZJAVA O SKLADNOSTI ES  
DECLARAȚIE DE CONFORMITATE CE  
EU VASTAVUSDEKLARATSIOON  
EK ATBILSTIBAS DEKLARACIJA  
EB ATITIKTIES DEKLARACIJA  
EC IZJAVA O SUKLADNOSTI  
EZ IZJAVA O USAGLAŠENOSTI  
ДЕКЛАРАЦИЯ СООТВЕТСТВИЯ НОРМАМ ЕС  
ДЕКЛАРАЦІЯ ВІДПОВІДНОСТІ НОРМАМ ЕС

**mitsubishi electric consumer products (thailand) co., ltd**  
**700/406 MOO 7, TAMBON DON HUA ROH, AMPHUR MUANG, CHONBURI 20000, THAILAND**

hereby declares under its sole responsibility that the air conditioners and heat pumps described below for use in residential, commercial and light-industrial environments:  
erklärt hiermit auf seine alleinige Verantwortung, dass die Klimaanlage(n) und Wärmepumpen für das häusliche, kommerzielle und leicht-industrielle Umfeld wie unten beschrieben:  
déclare par la présente et sous sa propre responsabilité que les climatiseurs et les pompes à chaleur décrits ci-dessous, destinés à un usage dans des environnements résidentiels, commerciaux et d'industrie légère :

verklaart hierbij onder eigen verantwoordelijkheid dat de voor residentiële, commerciële en licht-industriële omgevingen bestemde airconditioners en warmtepompen zoals onderstaand beschreven:

por la presente declara bajo su única responsabilidad que los acondicionadores de aire y bombas de calor descritas a continuación para su uso en entornos residenciales, comerciales y de industria ligera:

confirma con la presente, sotto la sua esclusiva responsabilità, che i condizionatori d'aria e le pompe di calore descritti di seguito e destinati all'utilizzo in ambienti residenziali, commerciali e semi-industriali:

με το παρόν πιστοποιώ με αποκλειστική της ευθύνης ότι οι τα κλιματιστικά και οι αντλίες θέρμανσης που περιγράφονται παρακάτω για χρήση σε οικιακό, επαγγελματικό και ελαφριάς βιομηχανίας περιβάλλοντα:

através da presente declara sob sua única responsabilidade que os aparelhos de ar condicionado e bombas de calor abaixo descritos para uso residencial, comercial e de indústria ligeira:  
vakuuttaa täten yksinomaista vastuullaan, että jäljempänä kuvatut asuinrakennuksiin, pientaloisuuskäyttöön ja kaupalliseen käyttöön tarkoitettuihin ilmastointilaitteisiin ja lämpöpumpuihin:

intygat härmed att luftkonditioneringarna och värmepumparna som beskrivs nedan för användning i bostäder, kommersiella miljöer och lätta industriella miljöer:  
ev, licarete ve hafif sanayi ortamlarında kullanılmaya elverişli üretilen ve aşağıda açıklanan klima ve ısıtma pompalarıyla ilgili aşağıdaki hususları yalnızca kendi sorumluluğunda beyan eder:

декларира на своя собствена отговорност, че климатизиците и термopомпите, описани по-долу, за употреба в жилищни, търговски и леки промишлени условия:  
niniejszym oświadczam na swoją wyłączną odpowiedzialność, że klimatyzatory i pompy ciepła opisane poniżej, są przeznaczone do zastosowań w środowisku mieszkalnym, handlowym i lekkim przemysłowym:

erklærer et fullstendig ansvar for undernævnte klimaanlegg og varmepumper ved bruk i boliger, samt kommersielle og lettindustrielle miljøer:  
avakuttaa täten yksinomaista vastuullaan, että jäljempänä kuvatut asuinrakennuksiin, pientaloisuuskäyttöön ja kaupalliseen käyttöön tarkoitettuihin ilmastointilaitteisiin ja lämpöpumpuihin:

timto na vlastní odpovědnost prohlašuje, že níže popsané klimatizační jednotky a tepelná čerpadla pro použití v obytných prostředích, komerčních prostředích a prostředích lehkého průmyslu:  
тімо на свою власну відповідальність, що нижче описані кліматизаційні одиниці та теплові насоси призначені для використання в житлових приміщеннях, торговельних приміщеннях та промислових приміщеннях:

tiempo na svoju výlučnú zodpovednosť vyhlasuje, že nasledovné klimatizačné jednotky a tepelné čerpadlá určené na používanie v obytných a obchodných priestoroch a v prostredí ľahkého priemyslu:

allírótt kizárólagos felelősségére nyilatkozik, hogy az alábbi lakossági, kereskedelmi és kisipari környezetben való használatra szánt klímaberendezések és hőszivattyúk:  
izjavlja pod izključno lastno odgovornostjo, da so spodaj navedene klimatske naprave in toplotne črpalke, namenjene uporabi v stanovanjskih, komercialnih in lahkoindustrijskih okoljih:

declară, prin prezenta, pe proprie răspundere, faptul că aparatele de climatizare și pompele de căldură descrise mai jos și destinate utilizării în medii rezidențiale, comerciale și din industria ușoară:  
kinnitab käesolevaga oma ainuvastutuse, et allpool toodud kliimaseadmed ja soojuspumbad on mõeldud kasutamiseks elu-, äri- ja kergtööstuskeskkondades:

ar so, vieni-personiski uznemoties atbildību, paziņo, ka tālāk aprakstītie gaisa kondicionētāji un siltumsūkņi ir paredzēti lietošanai dzīvojamajās, komercdarbības un vieglās rūpniecības telpās.  
šiuo vien tik savo atsakomybe pareiškia, kad toliau apibūdinti oro kondicionieriai ir šilumos siurbilai skirti naudoti gyvenamosiose, komercinėse ir lengvosios pramonės aplinkose:

ovime izjavljuje pod isključivom odgovornošću da su klimatizacijski uređaji i toplinske dizalice opisane u nastavku namijenjeni za upotrebu u stambenim i poslovnim okruženjima te okruženjima lake industrije:  
ovim izjavljuje na svoju isključivu odgovornost da su klima-uređaji i toplotne pumpe opisane u daljem tekstu za upotrebu u stambenim, komercijalnim okruženjima i okruženjima sa lakom industrijom:

настоящим заявляет и берет на себя исключительную ответственность за то, что кондиционеры и тепловые насосы, описанные ниже и предназначенные для эксплуатации в жилых помещениях, торговых залах и на предприятиях легкой промышленности:  
цим заявляє, беручи на себе повну відповідальність за це, що кондиціонери й теплові насоси, описані нижче й призначені для використання в житлових приміщеннях, торговельних залах і на підприємствах легкої промисловості:

**MITSUBISHI ELECTRIC, MXZ-2F33VF3, MXZ-2F42VF3, MXZ-2F53VF3, MXZ-2F53VFH3**

Note: Its serial number is on the nameplate of the product.  
Hinweis: Die Seriennummer befindet sich auf dem Kennschild des Produkts.  
Remarque : Le numéro de série de l'appareil se trouve sur la plaque du produit.  
Opmerking: het serienummer staat op het naamplaatje van het product.  
Nota: El número de serie se encuentra en la placa que contiene el nombre del producto.  
Nota: il numero di serie si trova sulla targhetta del prodotto.  
Σημείωση: Ο σειριακός του αριθμός βρίσκεται στην πινακίδα ονόματος του προϊόντος.  
Nota: o número de série encontra-se na placa que contém o nome do produto.  
Bemærk: Serienummeret står på produktets fabriksskilt.  
Obs: Serienumret finns på produktens namnplåt.  
Not: Serí numarastí úrinúin ísím plakasínda yer alir.  
Забелѣжка: Серијният му номер е на табелката на продукта.  
Uwaga: Numer seryjny znajduje się na tabliczce znamionowej produktu.  
Merk: Serienummeret befinner seg på navneplaten til produktet.

Huomautus: Sarjanumero on merkitty laitteen arvokilpeen.  
Poznámka: Příslušné sériové číslo se nachází na štítku produktu.  
Poznámka: Výrobné číslo sa nachádza na typovom štítku výrobku.  
Megjegyzés: A sorozatszám a termék adattábláján található.  
Opomba: serijska številka je zapisana na tipski ploščici enote.  
Notă: Numărul de serie este specificat pe plăcuța indicatoare a produsului.  
Märkus: Seerianumber asub toote andmesiltil.  
Piezīme. Sērijas numurs ir norādīts uz ierīces datu plāksnītēs.  
Pastaba. Sērijas numeris nurodytas gaminio vardinį duomenų lentelėje.  
Napomena: serijski broj nalazi se na natpisnoj pločici proizvoda.  
Napomena: Sérijski broj nalazi se na nazivnoj pločici proizvoda.  
Примечание: серийный номер указан на паспортной табличке изделия.  
Примітка. Серијний номер вказано на паспортній таблиці виробу.

Directives	Direttive	Direktiver	Směrnice	Direktiivid	Директивы
Richtlijnen	Объясн	Директиви	Smernice	Direktivas	Директиви
Directives	Directivas	Dyrektywy	Irányelvek	Direktivos	
Richtlijnen	Direktiver	Direktiver	Direktive	Direktive	
Directivas	Direktiv	Direktiv	Directive	Direktive	

2014/35/EU: Low Voltage Directive  
2006/42/EC: Machinery Directive  
2014/30/EU: Electromagnetic Compatibility Directive  
2009/125/EC: Energy-related Products Directive and Regulation (EU) No 206/2012  
2011/65/EU, (EU) 2015/863 and (EU) 2017/2102: RoHS Directive

Issued: 1 Nov. 2019  
THAILAND

Akira HIDAHA  
Manager, Quality Assurance Department

## Importer:

Mitsubishi Electric Europe B.V.  
Capronilaan 46, 1119 NS, Schiphol Rijk, The Netherlands

French Branch  
25, Boulevard des Bouvets, 92741 Nanterre Cedex, France

German Branch  
Mitsubishi-Electric-Platz 1, 40882 Ratingen, Germany

Belgian Branch  
Autobaan 2, 8210 Loppem, Belgium

Irish Branch  
Westgate Business Park, Ballymount, Dublin 24, Ireland

Italian Branch  
Centro Direzionale Colleoni, Palazzo Sirio-Ingresso 1 Viale Colleoni 7, 20864 Agrate Brianza (MB), Italy

Norwegian Branch  
Gneisveien 2D, 1914 Ytre Enebakk, Norway

Portuguese Branch  
Avda. do Forte, 10, 2799-514, Carnaxide, Lisbon, Portugal

Spanish Branch  
Carretera de Rubi 76-80 - Apdo. 420 08173 Sant Cugat del Valles (Barcelona), Spain

Scandinavian Branch  
Hammarbacken 14, P.O. Box 750 SE-19127, Sollentuna, Sweden

UK Branch  
Travellers Lane, Hatfield, Herts., AL10 8XB, England, U.K.

Polish Branch  
Krakowska 50, PL-32-083 Balice, Poland

MITSUBISHI ELECTRIC TURKEY ELEKTRİK ÜRÜNLERİ A.Ş.  
Şerifali Mah. Kale Sok. No: 41 34775 Ümraniye, İstanbul / Turkey

## **MITSUBISHI ELECTRIC CORPORATION**

HEAD OFFICE: TOKYO BUILDING, 2-7-3, MARUNOUCHI, CHIYODA-KU, TOKYO 100-8310, JAPAN