

# Wall mounted unit Air Conditioning Technical Data FTXM-A



FTXM20A2V1B  
FTXM20A5V1B  
FTXM25A2V1B  
FTXM25A5V1B  
FTXM35A2V1B  
FTXM35A5V1B  
FTXM42A2V1B  
FTXM42A5V1B  
FTXM50A2V1B  
FTXM50A5V1B  
FTXM60A2V1B  
FTXM71A2V1B



# TABLE OF CONTENTS

# FTXM-A

---

1	Features	4
	FTXM-A	4
2	Specifications	5
3	Options	7
4	Dimensional drawings	8
5	Centre of gravity	10
6	Piping diagrams	11
7	Wiring diagrams	15
	Wiring Diagrams - Three Phase	15
8	Sound data	17
	Sound Power Spectrum	17
	Sound Pressure Spectrum	21

# 1 Features































## 1 - 1 FTXM-A

### Attractive, wall mounted design with perfect indoor air quality

1

- > Seasonal efficiency values up to A+++ in cooling and heating in pair and multi
- > Comfort+: perfect comfort with homogeneous temperature throughout the room. The double flaps direct the air towards the ceiling in heating and along the wall in heating.
- > 2 area motion detection sensor: air flow is sent to a zone other than where the person is located at that moment; if no people are detected, the unit will automatically switch over to the energy-efficient setting.
- > Heat boost quickly heats up your home when starting up your air conditioner. Set temperature is reached 14% faster than a regular air conditioner (pair only)
- > Purifies the air of viruses, bacteria and fine dust thanks to the efficient dust filter
- > Using electrons to trigger chemical reactions with air borne particles, the Flash Streamer breaks down allergens such as pollen and fungal allergens and removes bothersome odours providing a better, cleaner air
- > Silver allergen removal and air purifying filter captures allergens such as pollen to ensure a steady supply of clean air
- > Voice command via Amazon Alexa or Google Assistant to control main functions such as set point, operation mode, fan speed, etc
- > Onecta app: control your indoor from any location with an app, via your local network or internet.
- > Quiet operation: down to 19dBA sound pressure level
- > 3-D air flow combines vertical and horizontal auto swing to circulate a stream of warm or cool air right to the corners of even large spaces



 Comfort+	 Heat boost	 Onecta app	 Econo mode	 2 area motion detection sensor	 Energy saving during standby mode	 Night set mode	 Fan only	 Powerful mode
 Auto cooling-heating changeover	 Whisper quiet	 Indoor unit silent operation	 Outdoor unit silent operation	 3-D air flow	 Vertical auto swing	 Horizontal auto swing	 Auto fan speed	 Dry programme
 Silver allergen removal and air purifying filter	 Flash Streamer	 Practically inaudible	 Titanium apatite deodorising filter	 Air purification filter	 Weekly timer	 Infrared remote control	 Wired remote control	 Centralised control
 Auto-restart	 Self diagnosis	 Multi model application						

# 2 Specifications

## 2 Specifications

Technical specifications					FTXM20A	FTXM25A	FTXM35A	FTXM42A	FTXM50A	FTXM60A	FTXM71A	
Power input	Cooling	Nom.	kW		0.019		0.029	0.031	0.034	0.035	0.037	
	Heating	Nom.	kW		0.018		0.019	0.035	0.036	0.034	0.041	
Casing	Colour		White									
Dimensions	Unit	Height	mm					298				
		Width	mm			804				997		
		Depth	mm			252				292		
	Packed unit	Height	mm			350					397	
		Width	mm			875					1,115	
		Depth	mm			380					377	
Weight	Unit		kg			11.5					14.5	
	Packed unit		kg			13					17	
Packing	Weight		kg			2					2.5	
	Length		mm			622					820	
Heat exchanger	Rows	Quantity						2				
		Fin pitch	mm			1.40				1.4		
	Face area		m <sup>2</sup>			0.214				0.281		
	Stages	Quantity							18			
		Passes	Quantity		2.20	2.40		3.43		6	4	
	Tube type				ø5 Hi-XB							
	Tube material				Copper							
	Tube diameter		mm			5					-	
	Fin	Type	Multi slit fin									
	Heat exchanger 2	Quantity			2					1		
		Length		mm			622				810	
Rows		Quantity							1			
		Fin pitch	mm				1.40				1.4	
Face area			m <sup>2</sup>		0.047			0.094			0.124	
Stages	Quantity			4				8				
Heat exchanger 3	Quantity		mm	-					1			
	Length		mm					622		810		
	Rows	Quantity			-				1			
		Fin pitch	mm		-				1.40		1.4	
	Stages	Quantity			-				4			
Fan	Type	Cross flow fan										
	Air flow rate	Cooling	High	m <sup>3</sup> /min	11.9	13.2	13.3	12.7	15.6	15.8		
Fan	Air flow rate	Cooling	Medium	m <sup>3</sup> /min	8.9	9.4	9.8	10.4	13.4	13.6		
				cfm	314	332	346	367	473	480		
				Low	m <sup>3</sup> /min	6.3	7.1	7.2	7.8	11.2	11.4	
		cfm	222	251	254	275	396	403				
		Silent operation	m <sup>3</sup> /min	4.9	4.6	5.0	5.9	8.6	9.3			
			cfm	173	162	177	208	304	328			
	Heating		High	m <sup>3</sup> /min	11.4	11.1	14.0	14.5	15.9	17.3		
		cfm		403	392	494	512	562	611			
		Medium		m <sup>3</sup> /min	9.2	9.4	10.0	11.5	14.6	15.3		
	cfm	325	332	353	406	516	540					
	Low	m <sup>3</sup> /min		6.9	7.1	8.6	11.8	12.3				
		cfm		244	251	304	417	434				
		Silent operation	m <sup>3</sup> /min	4.9	5.1	5.3	6.9	10.5	11.2			
cfm	173	180	187	244	371	396						
Fan motor	Model	DFH04E1VA					MM9E17Y33VA					
	Speed	Steps	5 + silent, + auto									
			Cooling	High	rpm	900	1,040	1,060	1,090	1,060	1,080	
		Medium			rpm	720	800	850	890	930	950	
		Low		rpm	570	670	680	720	800	820		
		Silent operation		rpm	480	510	510	600	650	700		
		Heating	High	rpm	880	890	1,100	1,110	1,050	1,120		
				Medium	rpm	750	790	860	950	980	1,010	
			Low	rpm	620	650	690	780	830	850		
			Silent operation	rpm	500	530	540	650	760	790		
		Output	Rated	W		35				68		
		Sound power level	Cooling		dB(A)	54	58		60			
			Heating		dB(A)	53		60		59	61	
		Sound pressure level	Cooling	High	dB(A)	41		45		46	47	
					Medium	dB(A)	33	37	38	40	42	43
Low	dB(A)			25	29	30	33	37	38			
Silent operation	dB(A)			19		21	27	30	32			
Heating	High		dB(A)	39		45	46	45	46			
			Medium	dB(A)	34	35	37	41		42		
	Low		dB(A)	26	27	28	29	34	36	37		
	Silent operation		dB(A)	20		21	31	33	34			

# 2 Specifications

2

Technical specifications				FTXM20A	FTXM25A	FTXM35A	FTXM42A	FTXM50A	FTXM60A	FTXM71A
Refrigerant	Type							R-32		
	GWP							675		
Piping connections	Liquid	OD	mm					6.4		
	Gas	OD	mm			9.5		12.7	15.9	
	Drain							16		
	Heat insulation							Both liquid and gas pipes		
Air filter	Type							Removable / washable		
Air direction control							Right, Left, Horizontal, Downward			
Temperature control							Microcomputer control			
Control systems	Infrared remote control							ARC466A86		
	Wired remote control							BRC073A1		

Standard accessories: Installation manual;Quantity: 1;

Standard accessories: Wireless remote control;Quantity: 1;

Standard accessories: Screw cover;Quantity: 2;

Standard accessories: AAA dry-cell batteries;Quantity: 2;

Standard accessories: Operation manual;Quantity: 1;

Standard accessories: Titanium apatite deodorizing filter;Quantity: 1;

Standard accessories: Silver particle filter;Quantity: 1;

Standard accessories: Remote control holder;Quantity: 1;

Standard accessories: Screw bag;Quantity: 1;

Electrical specifications				FTXM20A	FTXM25A	FTXM35A	FTXM42A	FTXM50A	FTXM60A	FTXM71A
Power supply	Name							V1		
	Phase							1~		
	Hz							50		
	V							220-240		
Current - 50Hz	A					-		0.3	0.4	
Wiring connections - 50Hz	For power supply	Quantity							3	
	Remark									3 for power supply, 4 for interunit wiring (Earth wire included)
Current	Nominal running current (RLA)	Cooling			0.3			0.4		
									-	

Cooling: indoor temp. 27°CDB, 19°CWB; outdoor temp. 35°CDB; equivalent piping length: 5m; level difference: 0m | Heating: indoor temp. 20°CDB; outdoor temp. 7°CDB, 6°CWB; equivalent refrigerant piping: 5m; level difference: 0m

# 3 Options

## 3-1 Options

FTXM-A

Option kit	Product name	Remark	Remark	Remark	Remark	A-MID		New Perfera		New Floor stand		OH4 mid. imp.		Emura 3		Zeta		OH4 PTH			
						Class	Capacity	Class	Capacity	Class	Capacity	Class	Capacity	Class	Capacity	Class	Capacity	Class	Capacity	Class	Capacity
Wired remote control	BR07941	(1)(3)	(2)(3)	(1)(3)	(2)(3)	FTXM120V1B	20 R32 R4S	FTXM120V1B	20 R32 R4S	FTXM120V1B	20 R32 R4S	FTXM120V1B	20 R32 R4S	FTXM120V1B	20 R32 R4S	FTXM120V1B	20 R32 R4S	FTXM120V1B	20 R32 R4S	FTXM120V1B	20 R32 R4S
Extension cord for wired remote control (3m)	BR0W91A03	(1)(3)	(2)(3)	(1)(3)	(2)(3)	FTXM120V1B	20 R32 R4S	FTXM120V1B	20 R32 R4S	FTXM120V1B	20 R32 R4S	FTXM120V1B	20 R32 R4S	FTXM120V1B	20 R32 R4S	FTXM120V1B	20 R32 R4S	FTXM120V1B	20 R32 R4S	FTXM120V1B	20 R32 R4S
Extension cord for wired remote control (8m)	BR0W91A08	(1)(3)	(2)(3)	(1)(3)	(2)(3)	FTXM120V1B	20 R32 R4S	FTXM120V1B	20 R32 R4S	FTXM120V1B	20 R32 R4S	FTXM120V1B	20 R32 R4S	FTXM120V1B	20 R32 R4S	FTXM120V1B	20 R32 R4S	FTXM120V1B	20 R32 R4S	FTXM120V1B	20 R32 R4S
Intelligent Tablet Controller	DC08A1A1	(1)(3)	(2)(3)	(1)(3)	(2)(3)	FTXM120V1B	20 R32 R4S	FTXM120V1B	20 R32 R4S	FTXM120V1B	20 R32 R4S	FTXM120V1B	20 R32 R4S	FTXM120V1B	20 R32 R4S	FTXM120V1B	20 R32 R4S	FTXM120V1B	20 R32 R4S	FTXM120V1B	20 R32 R4S
Wiring adaptor (normal open contact - normal open pulse contact)	HRP413B13	(1)(3)	(2)(3)	(1)(3)	(2)(3)	FTXM120V1B	20 R32 R4S	FTXM120V1B	20 R32 R4S	FTXM120V1B	20 R32 R4S	FTXM120V1B	20 R32 R4S	FTXM120V1B	20 R32 R4S	FTXM120V1B	20 R32 R4S	FTXM120V1B	20 R32 R4S	FTXM120V1B	20 R32 R4S
Wiring adaptor (normal open contact - normal open pulse contact)	HRP413B15	(1)(3)	(2)(3)	(1)(3)	(2)(3)	FTXM120V1B	20 R32 R4S	FTXM120V1B	20 R32 R4S	FTXM120V1B	20 R32 R4S	FTXM120V1B	20 R32 R4S	FTXM120V1B	20 R32 R4S	FTXM120V1B	20 R32 R4S	FTXM120V1B	20 R32 R4S	FTXM120V1B	20 R32 R4S
Interface adaptor for DIII-NET	KRP928B25	(1)(3)	(2)(3)	(1)(3)	(2)(3)	FTXM120V1B	20 R32 R4S	FTXM120V1B	20 R32 R4S	FTXM120V1B	20 R32 R4S	FTXM120V1B	20 R32 R4S	FTXM120V1B	20 R32 R4S	FTXM120V1B	20 R32 R4S	FTXM120V1B	20 R32 R4S	FTXM120V1B	20 R32 R4S
Central remote control	DCS302CA1	(1)(3)	(2)(3)	(1)(3)	(2)(3)	FTXM120V1B	20 R32 R4S	FTXM120V1B	20 R32 R4S	FTXM120V1B	20 R32 R4S	FTXM120V1B	20 R32 R4S	FTXM120V1B	20 R32 R4S	FTXM120V1B	20 R32 R4S	FTXM120V1B	20 R32 R4S	FTXM120V1B	20 R32 R4S
Unified ON/OFF controller	DCS311B41	(1)(3)	(2)(3)	(1)(3)	(2)(3)	FTXM120V1B	20 R32 R4S	FTXM120V1B	20 R32 R4S	FTXM120V1B	20 R32 R4S	FTXM120V1B	20 R32 R4S	FTXM120V1B	20 R32 R4S	FTXM120V1B	20 R32 R4S	FTXM120V1B	20 R32 R4S	FTXM120V1B	20 R32 R4S
Schedule timer	DTF261B41	(1)(3)	(2)(3)	(1)(3)	(2)(3)	FTXM120V1B	20 R32 R4S	FTXM120V1B	20 R32 R4S	FTXM120V1B	20 R32 R4S	FTXM120V1B	20 R32 R4S	FTXM120V1B	20 R32 R4S	FTXM120V1B	20 R32 R4S	FTXM120V1B	20 R32 R4S	FTXM120V1B	20 R32 R4S
Intelligent Touch Manager	DCN60A41	(1)(3)	(2)(3)	(1)(3)	(2)(3)	FTXM120V1B	20 R32 R4S	FTXM120V1B	20 R32 R4S	FTXM120V1B	20 R32 R4S	FTXM120V1B	20 R32 R4S	FTXM120V1B	20 R32 R4S	FTXM120V1B	20 R32 R4S	FTXM120V1B	20 R32 R4S	FTXM120V1B	20 R32 R4S
Modbus interface	FXM8DA7H	(1)(3)	(2)(3)	(1)(3)	(2)(3)	FTXM120V1B	20 R32 R4S	FTXM120V1B	20 R32 R4S	FTXM120V1B	20 R32 R4S	FTXM120V1B	20 R32 R4S	FTXM120V1B	20 R32 R4S	FTXM120V1B	20 R32 R4S	FTXM120V1B	20 R32 R4S	FTXM120V1B	20 R32 R4S
Modbus gateway	RTD-0A	(1)(3)	(2)(3)	(1)(3)	(2)(3)	FTXM120V1B	20 R32 R4S	FTXM120V1B	20 R32 R4S	FTXM120V1B	20 R32 R4S	FTXM120V1B	20 R32 R4S	FTXM120V1B	20 R32 R4S	FTXM120V1B	20 R32 R4S	FTXM120V1B	20 R32 R4S	FTXM120V1B	20 R32 R4S
KNX interface	KLIC-00	(1)(3)	(2)(3)	(1)(3)	(2)(3)	FTXM120V1B	20 R32 R4S	FTXM120V1B	20 R32 R4S	FTXM120V1B	20 R32 R4S	FTXM120V1B	20 R32 R4S	FTXM120V1B	20 R32 R4S	FTXM120V1B	20 R32 R4S	FTXM120V1B	20 R32 R4S	FTXM120V1B	20 R32 R4S
Titanium apatite deodorising filter without frame	KAF97A46	(1)	(1)	(1)	(1)	FTXM120V1B	20 R32 R4S	FTXM120V1B	20 R32 R4S	FTXM120V1B	20 R32 R4S	FTXM120V1B	20 R32 R4S	FTXM120V1B	20 R32 R4S	FTXM120V1B	20 R32 R4S	FTXM120V1B	20 R32 R4S	FTXM120V1B	20 R32 R4S
Silver particle filter (Ag-ion) with frame	KAF97A42	(1)	(1)	(1)	(1)	FTXM120V1B	20 R32 R4S	FTXM120V1B	20 R32 R4S	FTXM120V1B	20 R32 R4S	FTXM120V1B	20 R32 R4S	FTXM120V1B	20 R32 R4S	FTXM120V1B	20 R32 R4S	FTXM120V1B	20 R32 R4S	FTXM120V1B	20 R32 R4S
Conversion wire harness	EW021	(1)	(1)	(1)	(1)	FTXM120V1B	20 R32 R4S	FTXM120V1B	20 R32 R4S	FTXM120V1B	20 R32 R4S	FTXM120V1B	20 R32 R4S	FTXM120V1B	20 R32 R4S	FTXM120V1B	20 R32 R4S	FTXM120V1B	20 R32 R4S	FTXM120V1B	20 R32 R4S

Notes

- Standard accessory
- This option features a(n) S21 connector. To connect this option to the indoor unit, therefore conversion wire harness EKRS21 is required.
- This option cannot operate together with the wireless LAN functionality that is a standard feature of the indoor unit.  
When connecting this option to the indoor unit, turn off the indoor unit's wireless LAN functionality.
- Obsolete option.
- Production of this option finished, replaced by new option KRP413BB1S.

3D120481M



# 4 Dimensional drawings

## 4 - 1 Dimensional Drawings

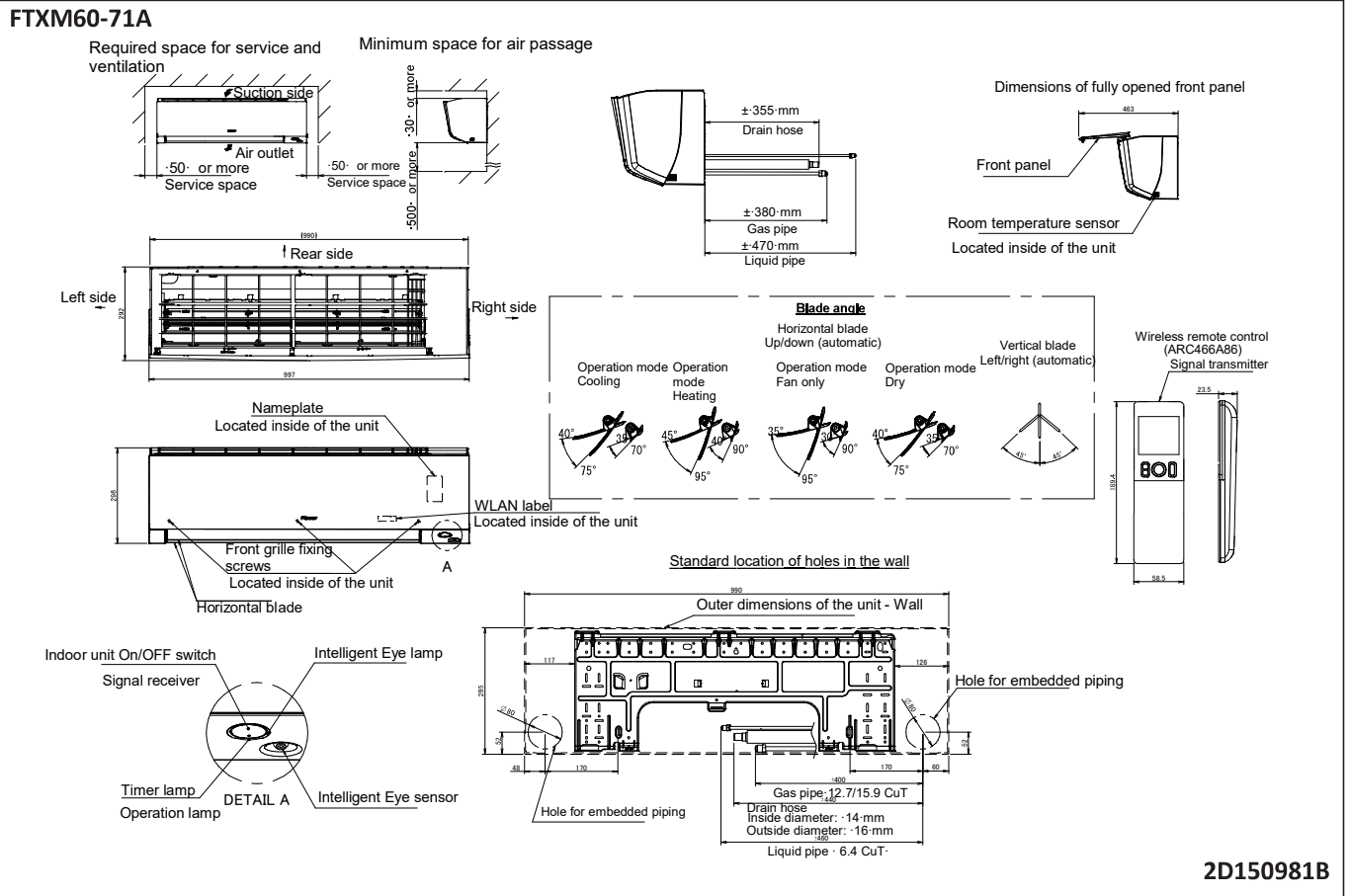

# 5 Centre of gravity

## 5 - 1 Centre of Gravity

5

FTXM20-50A

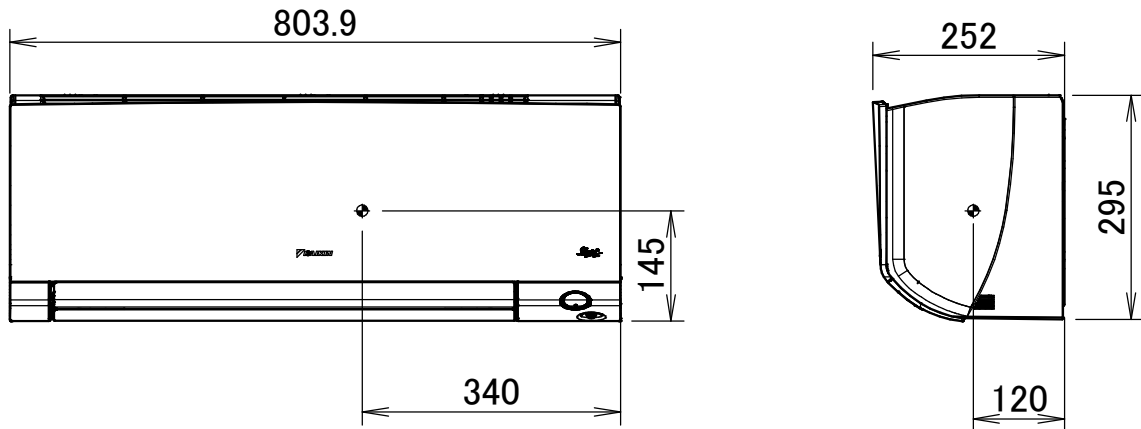

4D148220

FTXM60-71A

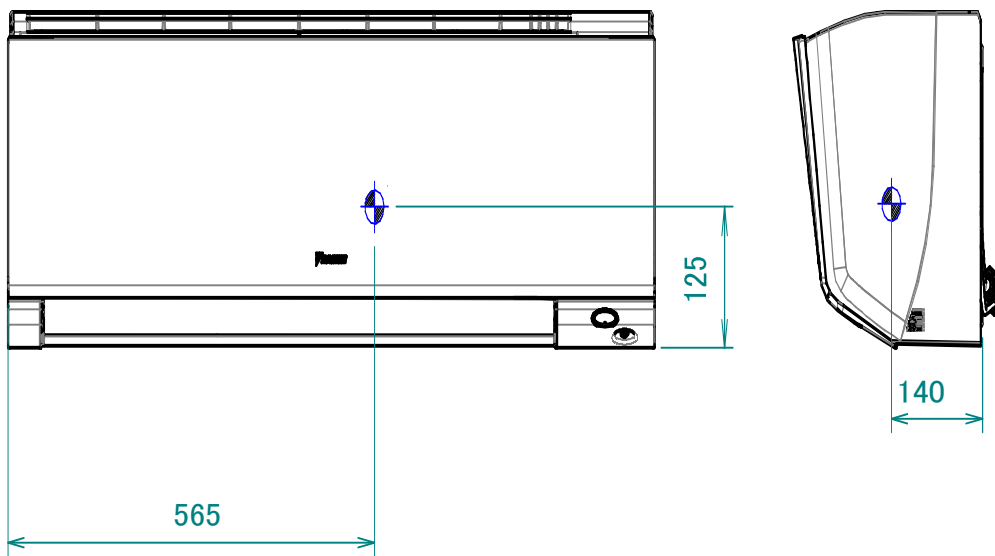

4D150677

# 6 Piping diagrams

## 6 - 1 Piping Diagrams

FTXM20-25A

### Indoor unit

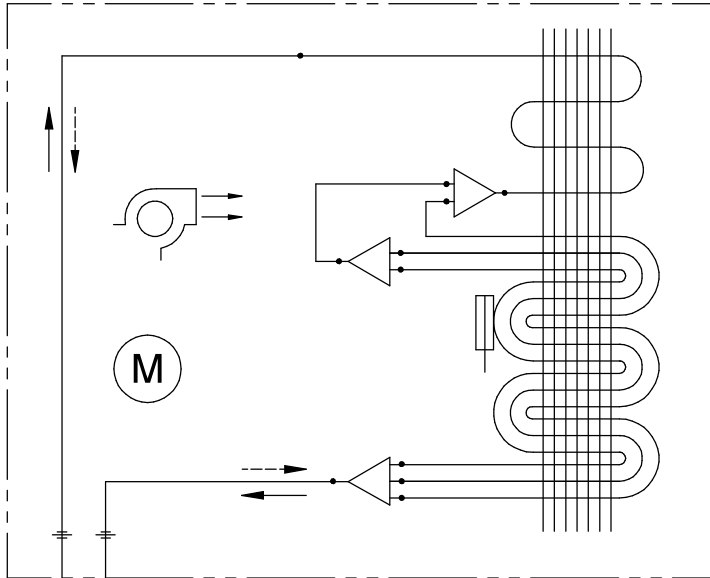

Field piping  
·9.5· CuT  
Field piping  
·6.4· CuT

**Legend**

- Fan motor
- Thermistor
- Crossflow fan
- Distributor
- Heat exchanger

**Refrigerant flow**

- Cooling
- Heating

4D147901

FTXM35A

### Indoor unit

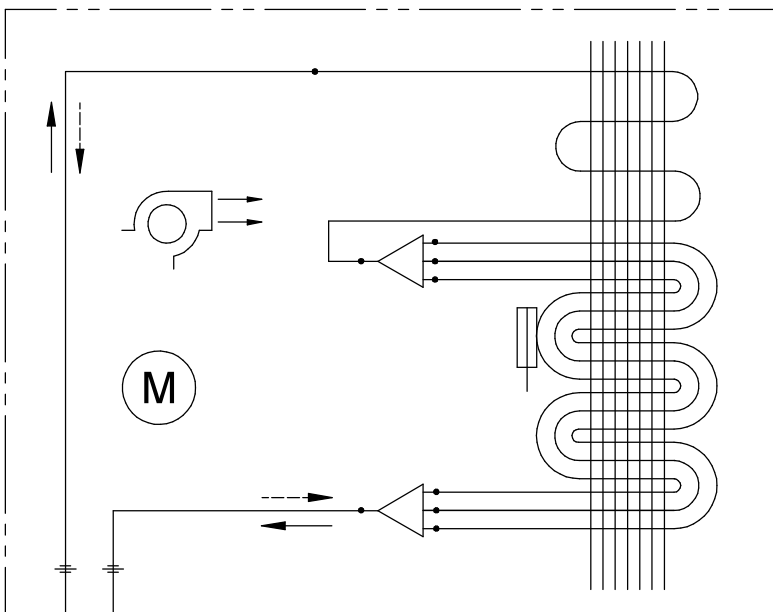

Field piping  
·9.5· CuT  
Field piping  
·6.4· CuT

**Legend**

- Fan motor
- Thermistor
- Crossflow fan
- Distributor
- Heat exchanger

**Refrigerant flow**

- Cooling
- Heating

4D147902

# 6 Piping diagrams

## 6 - 1 Piping Diagrams

6

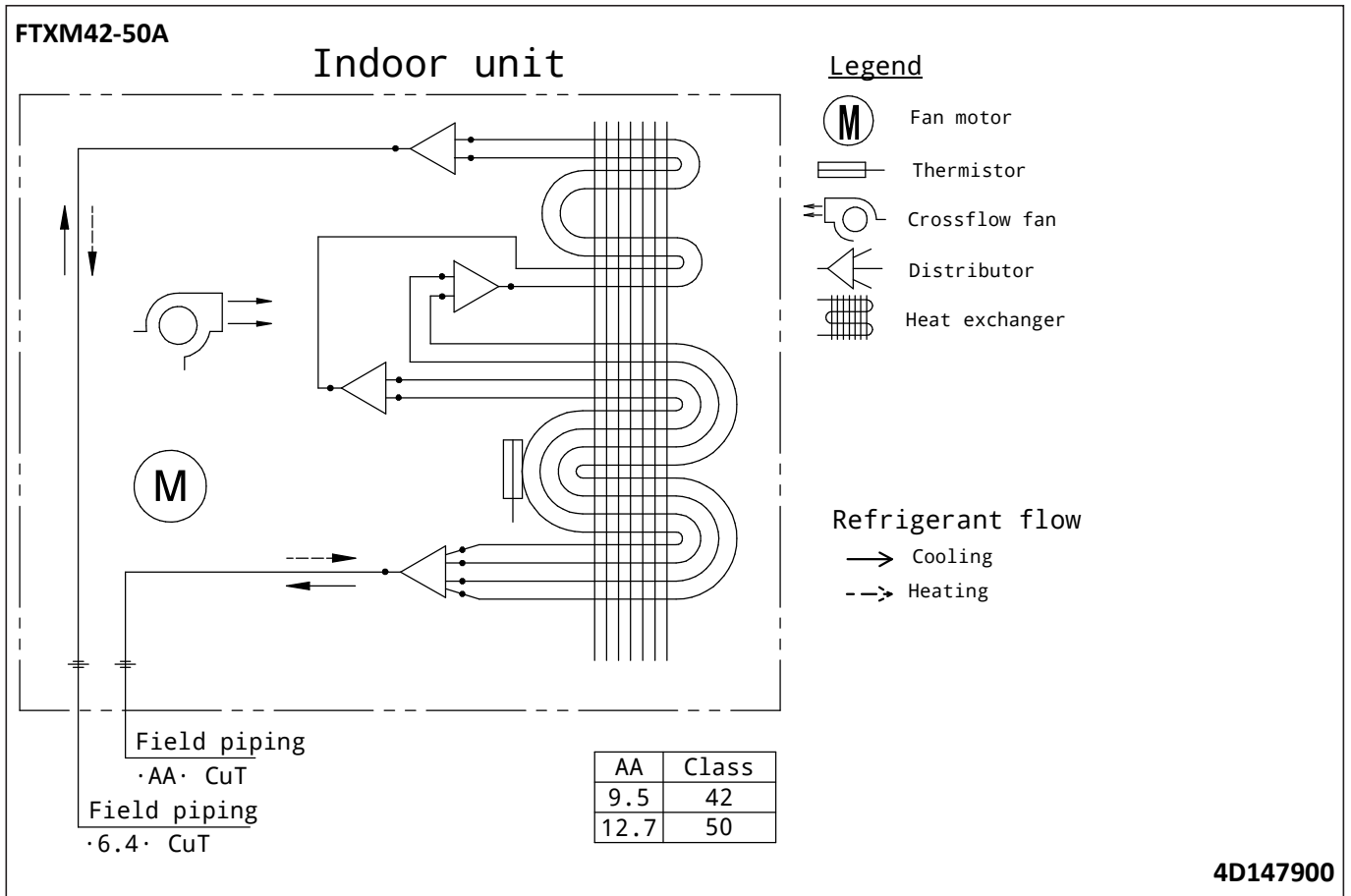

# 6 Piping diagrams

## 6 - 1 Piping Diagrams

FTXM60A

Indoor unit

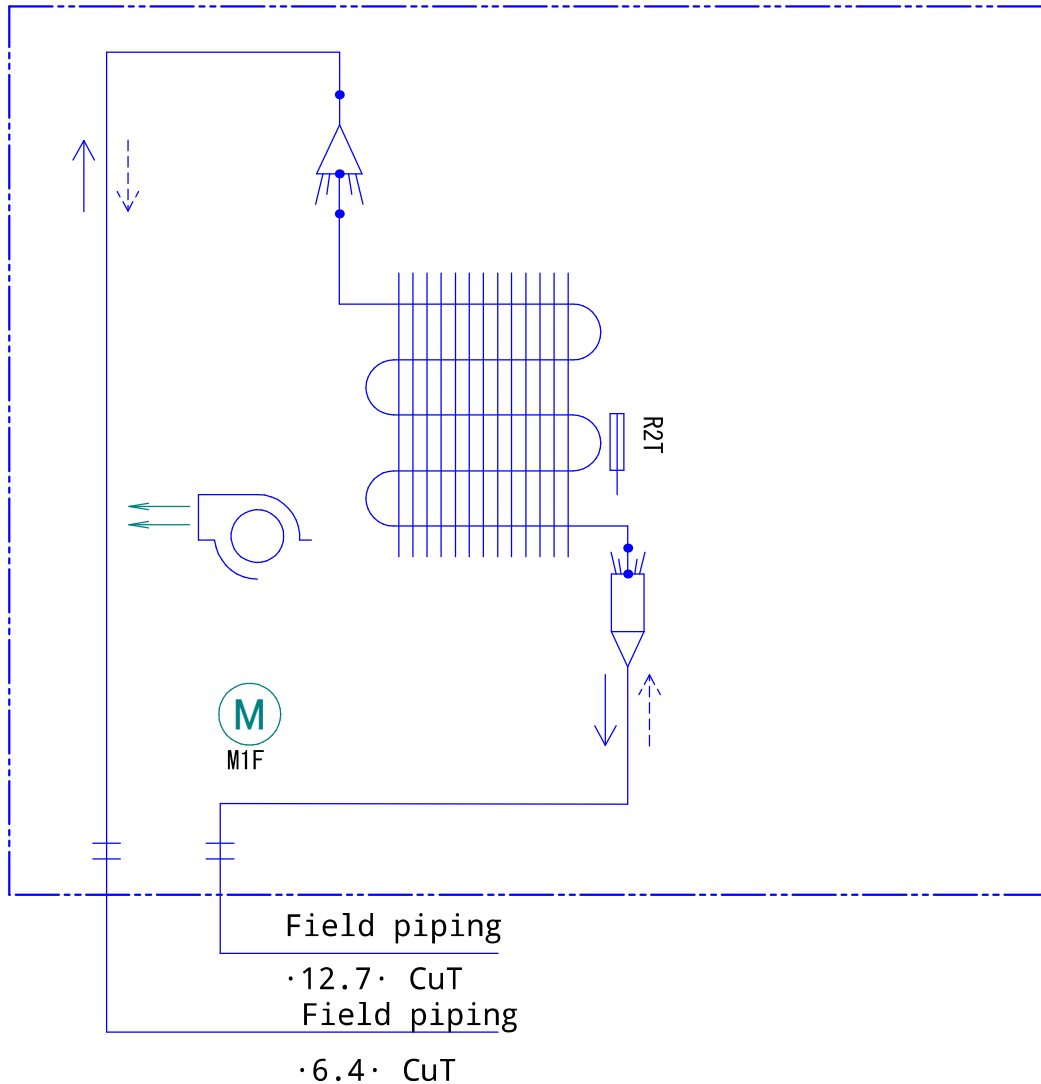

Refrigerant flow

→ Cooling

- - - -> Heating

**Legend**

- Fan motor
- Distributor
- Heat exchanger
- Crossflow fan
- Thermistor (heat exchanger)

4D101332E

# 6 Piping diagrams

## 6 - 1 Piping Diagrams

6

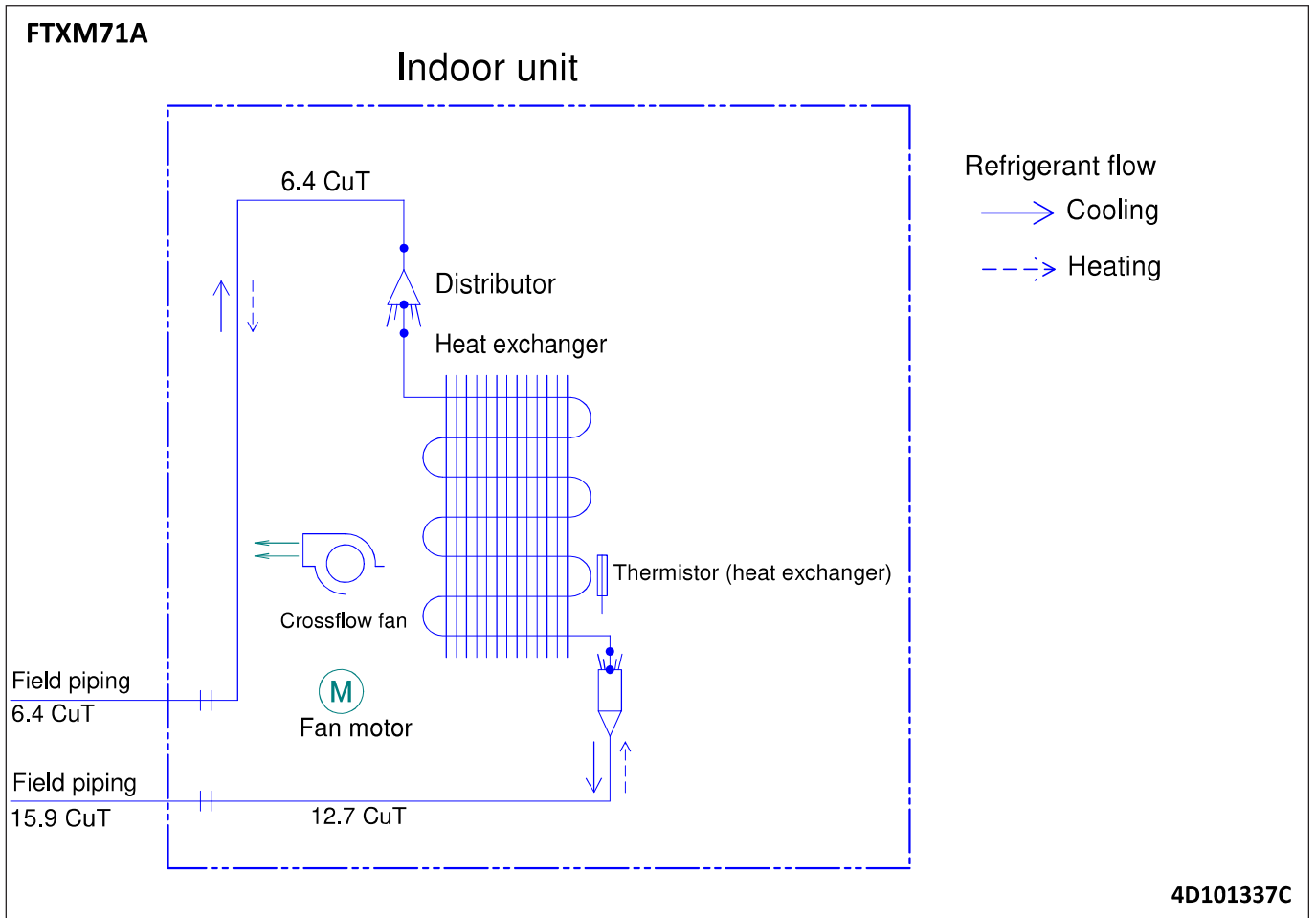

# 7 Wiring diagrams

## 7 - 1 Wiring Diagrams - Three Phase

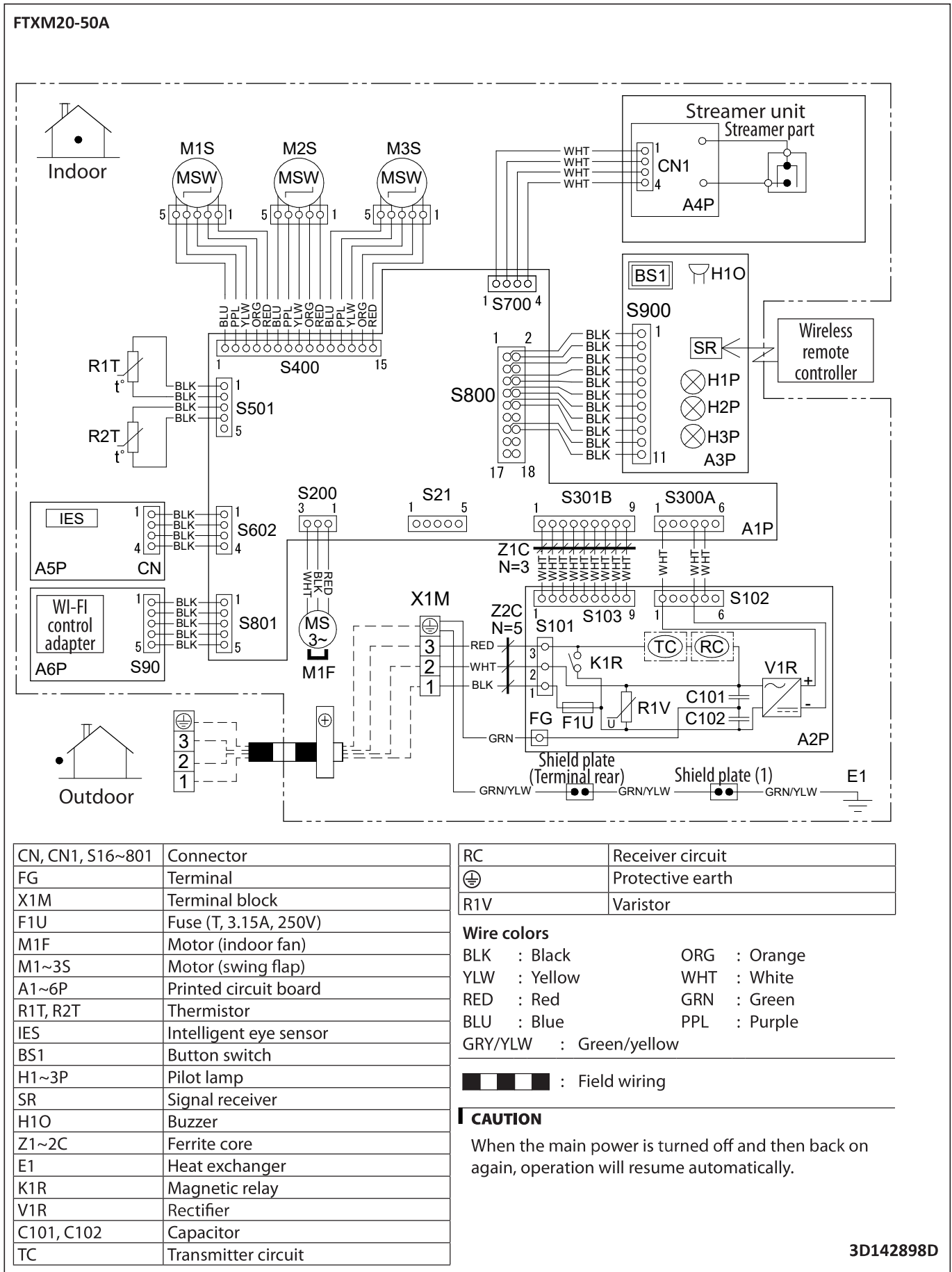

# 7 Wiring diagrams

## 7 - 1 Wiring Diagrams - Three Phase

7

FTXM60-71A

120

70

CN, CN1, S16~801	Connector
FG	Terminal
X1M	Terminal block
F1U	Fuse (T, 3.15A, 250V)
M1F	Motor (indoor fan)
M1~2S	Motor (swing flap)
A1~6P	Printed circuit board
R1T, R2T	Thermistor
IES	Intelligent eye sensor
BS1	Button switch
H1~3P	Pilot lamp
SR	Signal receiver
H1O	Buzzer
Z1~3C	Ferrite core
E1	Heat exchanger
K1R	Magnetic relay
V1R	Rectifier
C101, C102	Capacitor
TC	Transmitter circuit
RC	Receiver circuit
⊕	Protective earth
R1V	Varistor

**Wire colors**

BLK	: Black
YLW	: Yellow
RED	: Red
WHT	: White
GRN	: Green
GRN/YLW	: Green/Yellow
GRY	: Gray

Field wiring:

**CAUTION**

When the main power is turned OFF and then back ON again, operation will resume automatically.

**Wiring diagram**

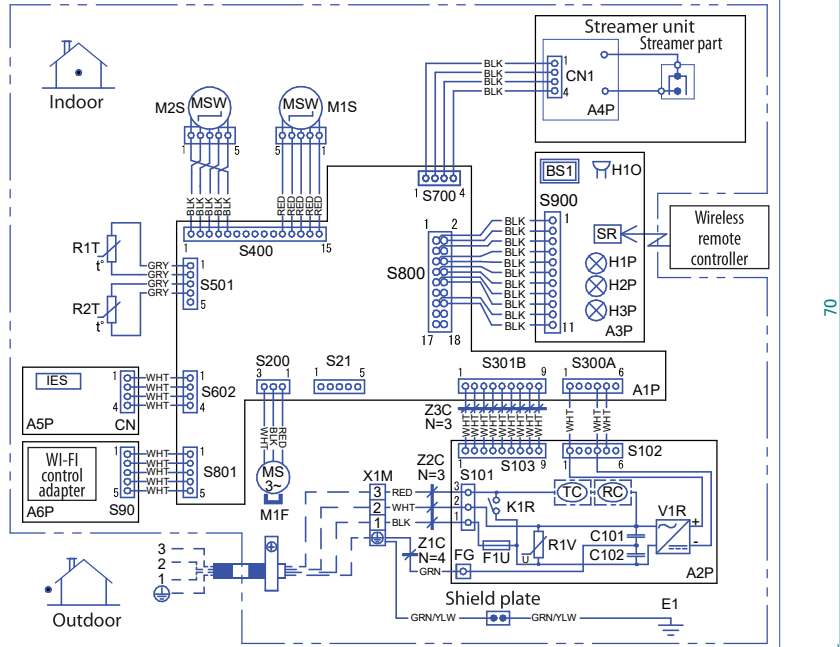

**NOTES**

1. Size: height 70 × width 120.
2. Refer to purchasing specification AS303002 unless otherwise specified.

2D146746B

# 8 Sound data

## 8 - 1 Sound Power Spectrum

### FTXM20A

#### Cooling

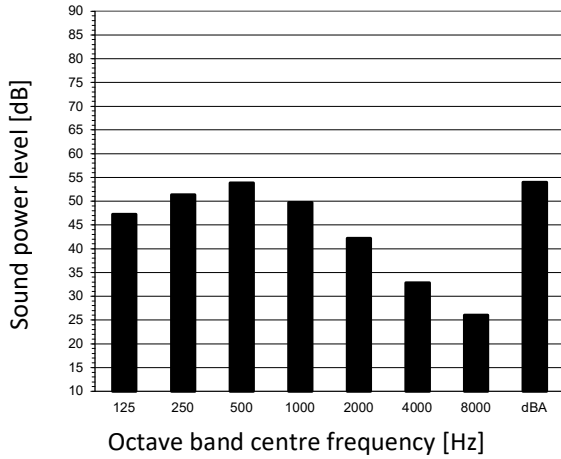

#### Heating

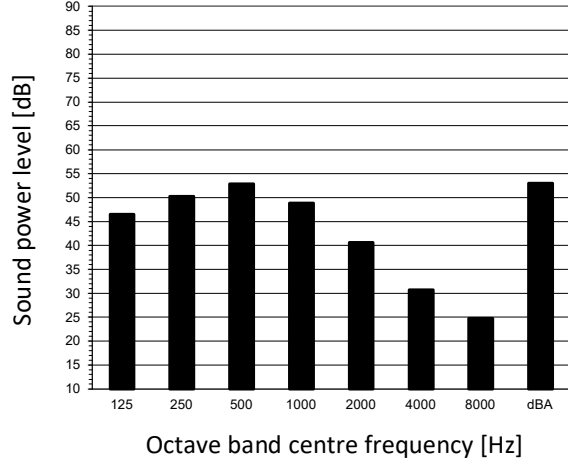

Fan speed: High

Notes

1. dBA = A-weighted sound power level (A scale according to IEC).
2. Reference acoustic intensity 0dB =  $\cdot 10^{-12}$  W/m<sup>2</sup>.
3. Measured according to ISO 3744

4D148880

### FTXM25A

#### Cooling

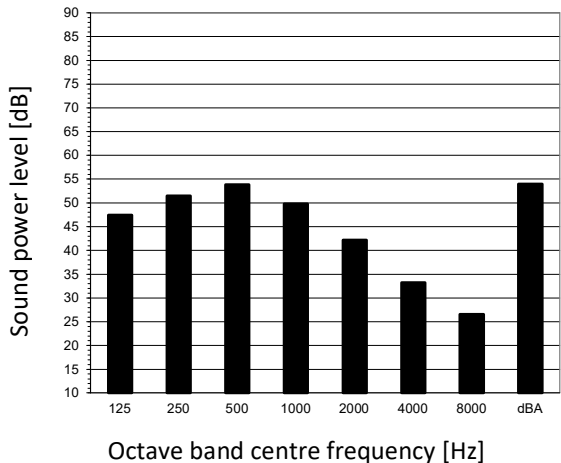

#### Heating

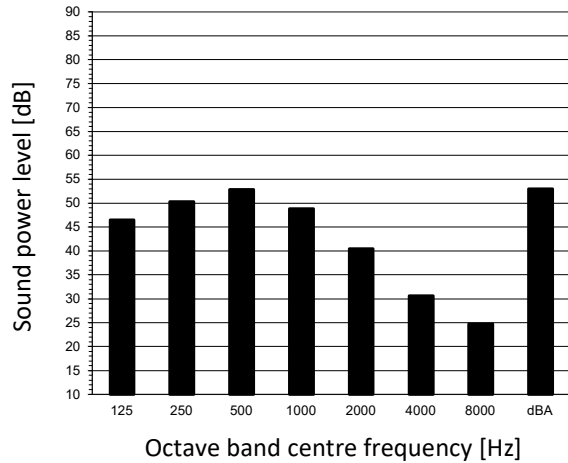

Fan speed: High

Notes

1. dBA = A-weighted sound power level (A scale according to IEC).
2. Reference acoustic intensity 0dB =  $\cdot 10^{-12}$  W/m<sup>2</sup>.
3. Measured according to ISO 3744

4D148881

# 8 Sound data

## 8 - 1 Sound Power Spectrum

8

### FTXM35A

#### Cooling

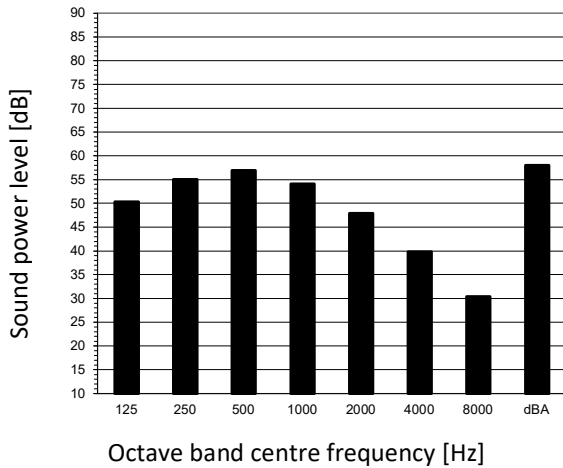

#### Heating

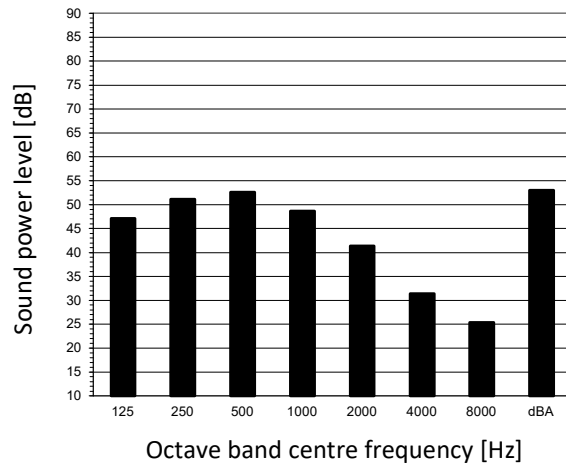

Fan speed: High

- Notes
1. dBA = A-weighted sound power level (A scale according to IEC).
  2. Reference acoustic intensity 0dB =  $10^{-12}$  W/m<sup>2</sup>.
  3. Measured according to ISO 3744

4D148882

### FTXM42A

#### Cooling

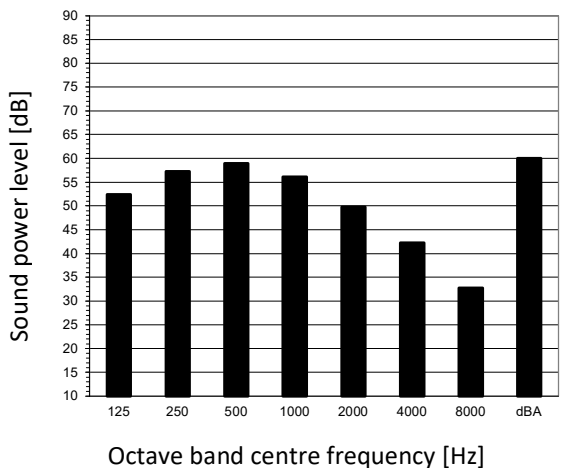

#### Heating

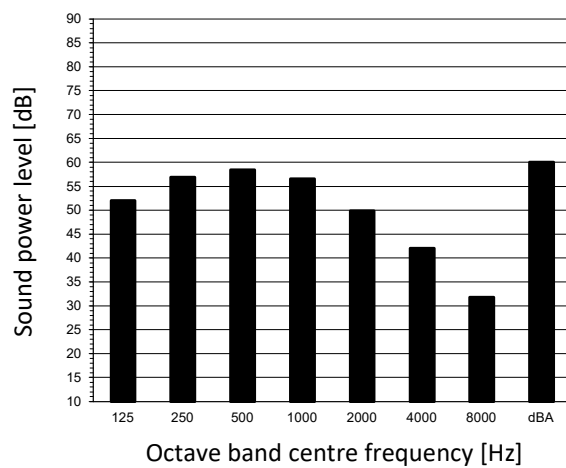

Fan speed: High

- Notes
1. dBA = A-weighted sound power level (A scale according to IEC).
  2. Reference acoustic intensity 0dB =  $10^{-12}$  W/m<sup>2</sup>.
  3. Measured according to ISO 3744

4D148883

# 8 Sound data

## 8 - 1 Sound Power Spectrum

### FTXM50A

Cooling

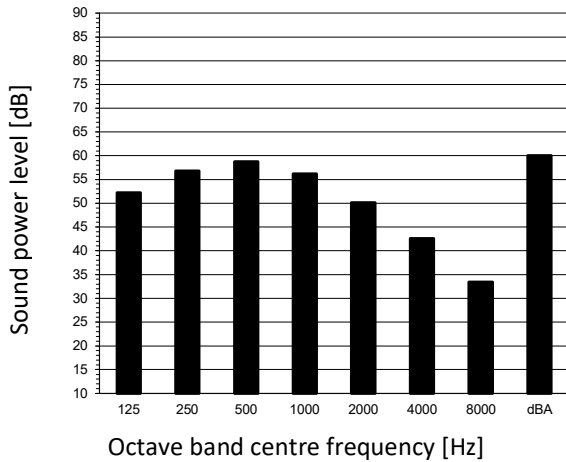

Heating

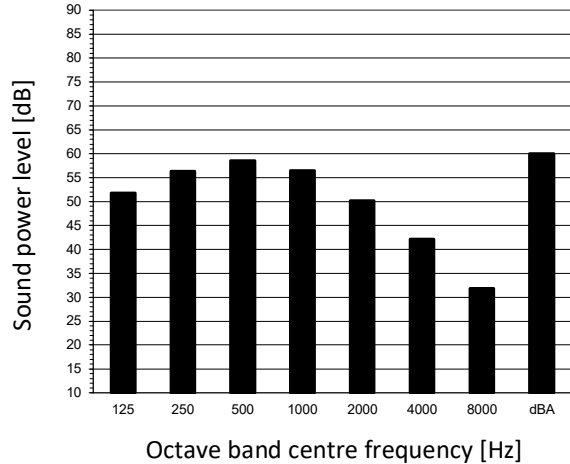

■ Fan speed: High

Notes

1. dBA = A-weighted sound power level (A scale according to IEC).
2. Reference acoustic intensity 0dB =  $\cdot 10^{-12}$  W/m<sup>2</sup>.
3. Measured according to ISO 3744

4D148884

### FTXM60A

Cooling

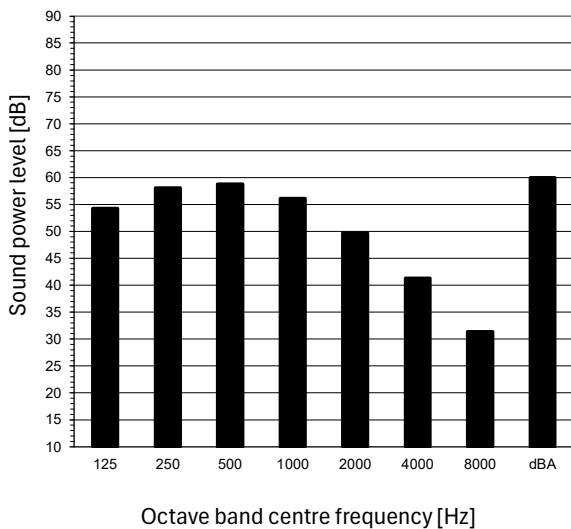

Heating

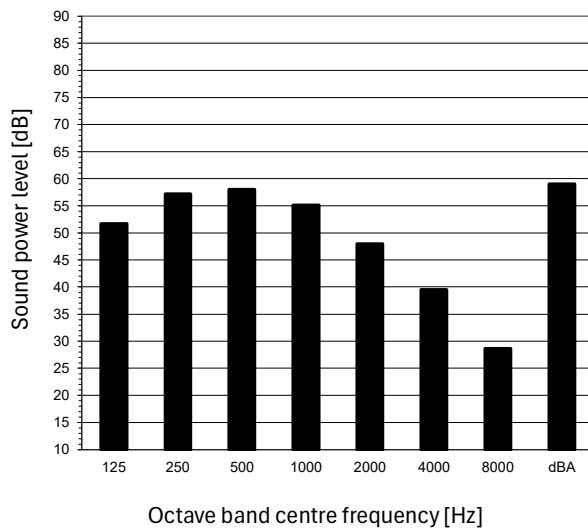

■ Fan speed: High

Notes

1. dBA = A-weighted sound power level (A scale according to IEC).
2. Reference acoustic intensity 0dB =  $\cdot 10^{-12}$  W/m<sup>2</sup>.
3. Measured according to ISO 3744

4D151794A

# 8 Sound data

## 8 - 1 Sound Power Spectrum

8

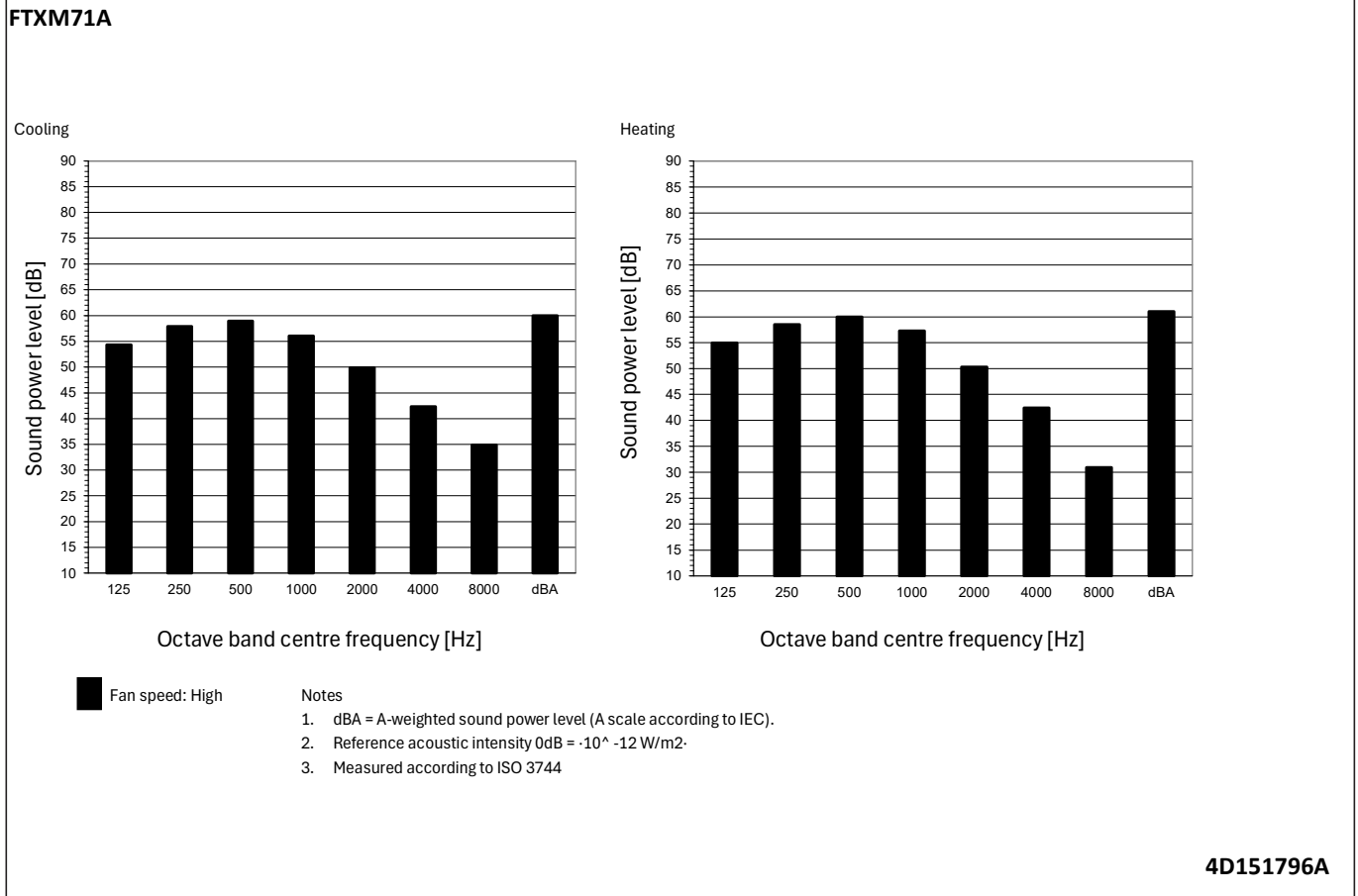

# 8 Sound data

## 8 - 2 Sound Pressure Spectrum

### FTXM20A

Cooling mode

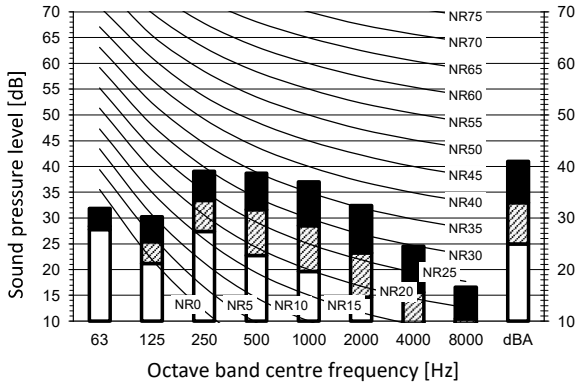

Heating mode

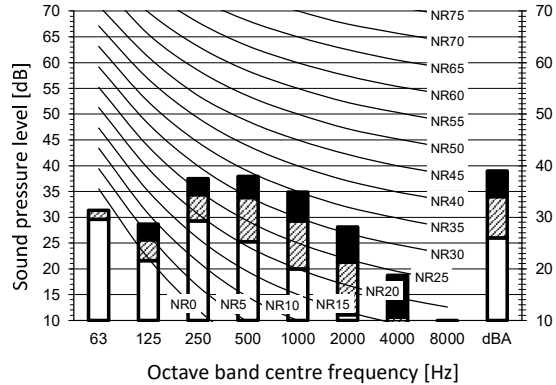

**Legend**

dBA = A-weighted sound pressure level (A scale according to IEC).

A Scale

- B Fan speed: High
- C Fan speed: Medium
- D Fan speed: Low

**Location of microphone**

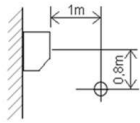

Cooling Total dB

A	B	C	D
dBA	41	33	25

Heating Total dB

A	B	C	D
dBA	39	34	26

**Notes**

1. Operating conditions: power source 220-240 V/220 V 50/60 Hz; JIS standard
2. Background noise already taken into account.
3. Operating noise varies depending on operation and ambient conditions.
4. The operation noise measuring method is in accordance with JISC9612.
5. Measuring location: anechoic chamber

4D148915A

### FTXM25A

Cooling mode

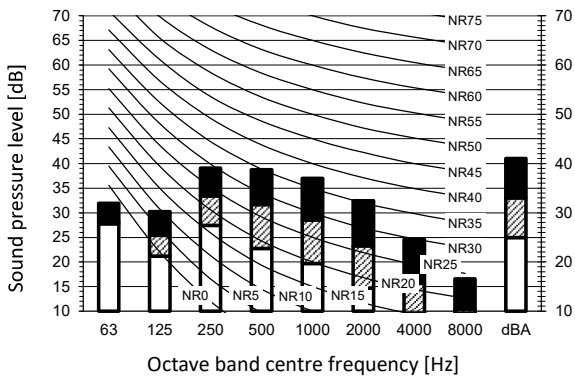

Heating mode

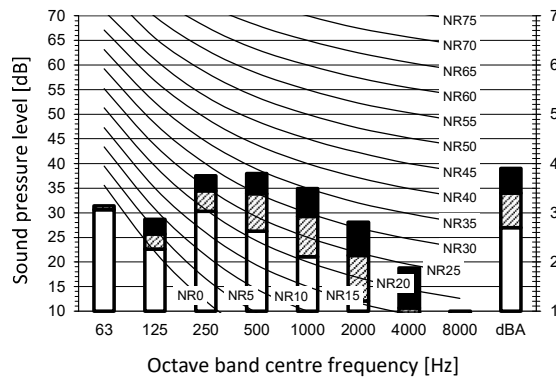

**Legend**

dBA = A-weighted sound pressure level (A scale according to IEC).

A Scale

- B Fan speed: High
- C Fan speed: Medium
- D Fan speed: Low

**Location of microphone**

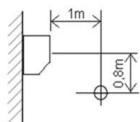

Cooling Total dB

A	B	C	D
dBA	41	33	25

Heating Total dB

A	B	C	D
dBA	39	34	27

**Notes**

1. Operating conditions: power source 220-240 V/220 V 50/60 Hz; JIS standard
2. Background noise already taken into account.
3. Operating noise varies depending on operation and ambient conditions.
4. The operation noise measuring method is in accordance with JISC9612.
5. Measuring location: anechoic chamber

4D148916A

# 8 Sound data

## 8 - 2 Sound Pressure Spectrum

8

### FTXM35A

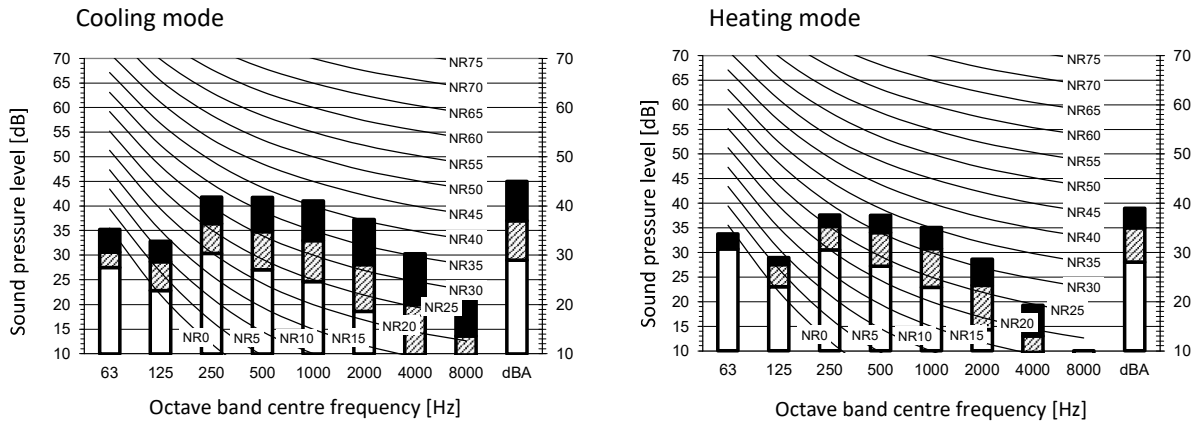

**Legend**  
 dBA = A-weighted sound pressure level (A scale according to IEC).  
**A Scale**  
 B Fan speed: High  
 C Fan speed: Medium  
 D Fan speed: Low

Cooling	Total dB			
	A	B	C	D
dBA	45	37	29	

Heating	Total dB			
	A	B	C	D
dBA	39	35	28	

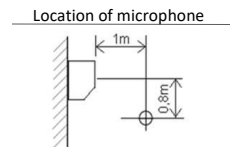

- Notes**
1. Operating conditions: power source 220-240 V/220 V 50/60 Hz; JIS standard
  2. Background noise already taken into account.
  3. Operating noise varies depending on operation and ambient conditions.
  4. The operation noise measuring method is in accordance with JISC9612.
  5. Measuring location: anechoic chamber

4D148918A

### FTXM42A

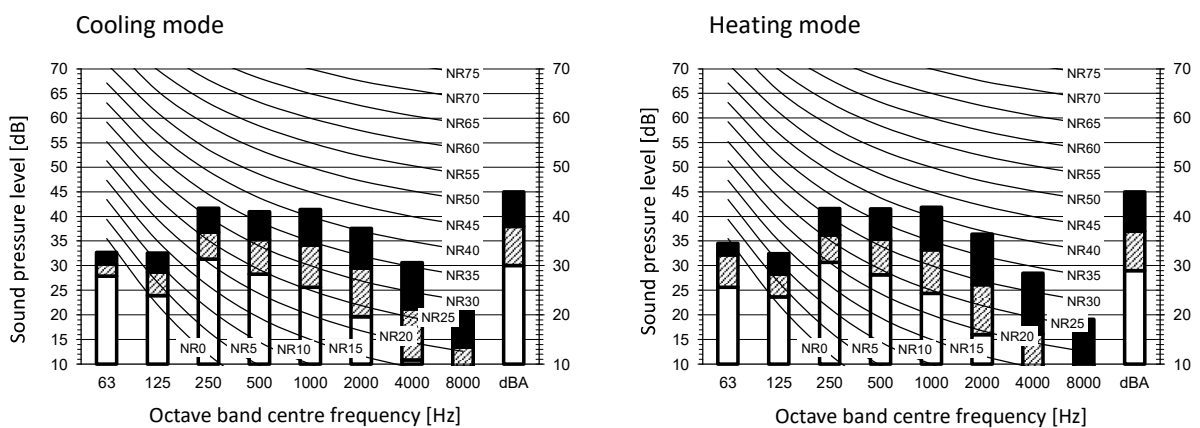

**Legend**  
 dBA = A-weighted sound pressure level (A scale according to IEC).  
**A Scale**  
 B Fan speed: High  
 C Fan speed: Medium  
 D Fan speed: Low

Cooling	Total dB			
	A	B	C	D
dBA	45	38	30	

Heating	Total dB			
	A	B	C	D
dBA	45	37	29	

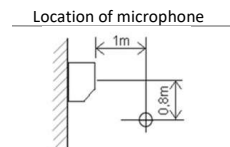

- Notes**
1. Operating conditions: power source 220-240 V/220 V 50/60 Hz; JIS standard
  2. Background noise already taken into account.
  3. Operating noise varies depending on operation and ambient conditions.
  4. The operation noise measuring method is in accordance with JISC9612.
  5. Measuring location: anechoic chamber

4D148919A

# 8 Sound data

## 8 - 2 Sound Pressure Spectrum

### FTXM50A

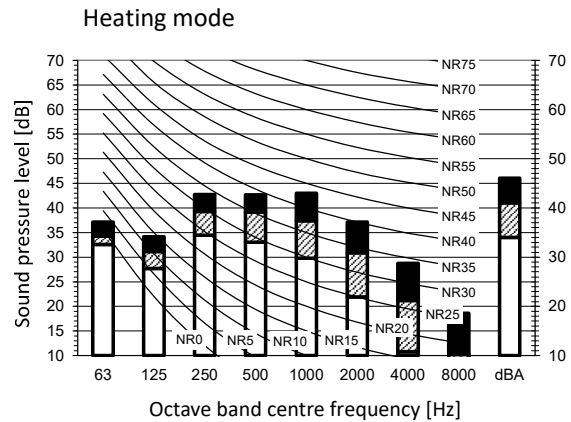
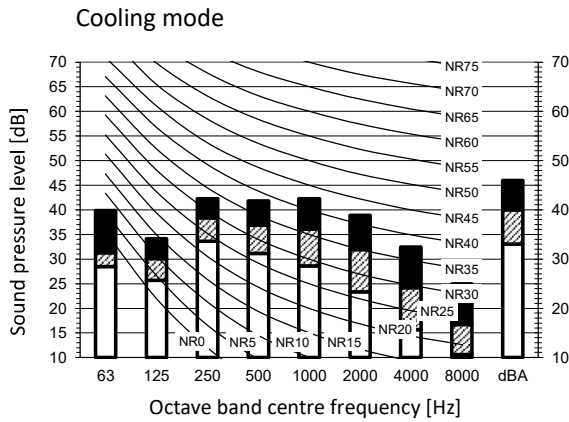

**Legend**

dBA = A-weighted sound pressure level (A scale according to IEC).

**A Scale**

- B Fan speed: High
- C Fan speed: Medium
- D Fan speed: Low

**Location of microphone**

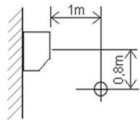

**Cooling Total dB**

A	B	C	D
dBA	46	40	33

**Heating Total dB**

A	B	C	D
dBA	46	41	34

**Notes**

1. Operating conditions: power source 220-240 V/220 V 50/60 Hz; JIS standard
2. Background noise already taken into account.
3. Operating noise varies depending on operation and ambient conditions.
4. The operation noise measuring method is in accordance with JISC9612.
5. Measuring location: anechoic chamber

4D148920A

### FTXM60A

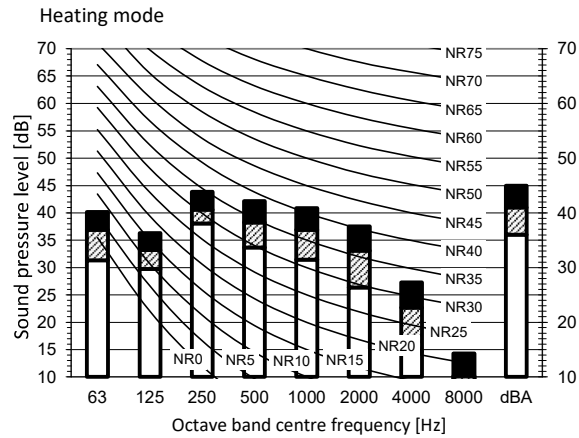
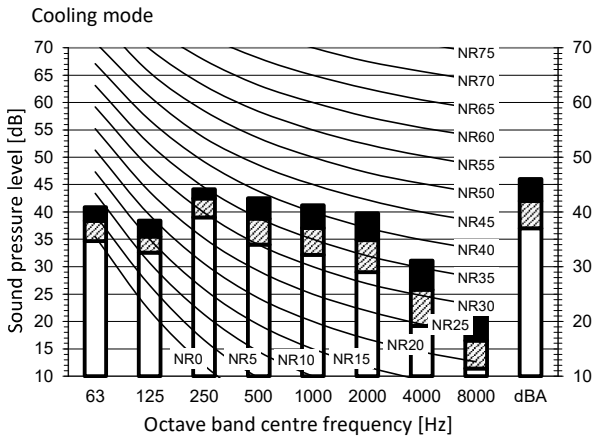

**Legend**

dBA = A-weighted sound pressure level (A scale according to IEC).

**A Scale**

- B Fan speed: High
- C Fan speed: Medium
- D Fan speed: Low

**Location of microphone**

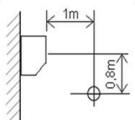

**Cooling Total dB**

A	B	C	D
dBA	46	42	37

**Heating Total dB**

A	B	C	D
dBA	45	41	36

**Notes**

1. Operating conditions: power source 220-240 V/220 V 50/60 Hz; JIS standard
2. Background noise already taken into account.
3. Operating noise varies depending on operation and ambient conditions.
4. The operation noise measuring method is in accordance with JISC9612.
5. Measuring location: anechoic chamber

4D151795A

# 8 Sound data

## 8 - 2 Sound Pressure Spectrum

8

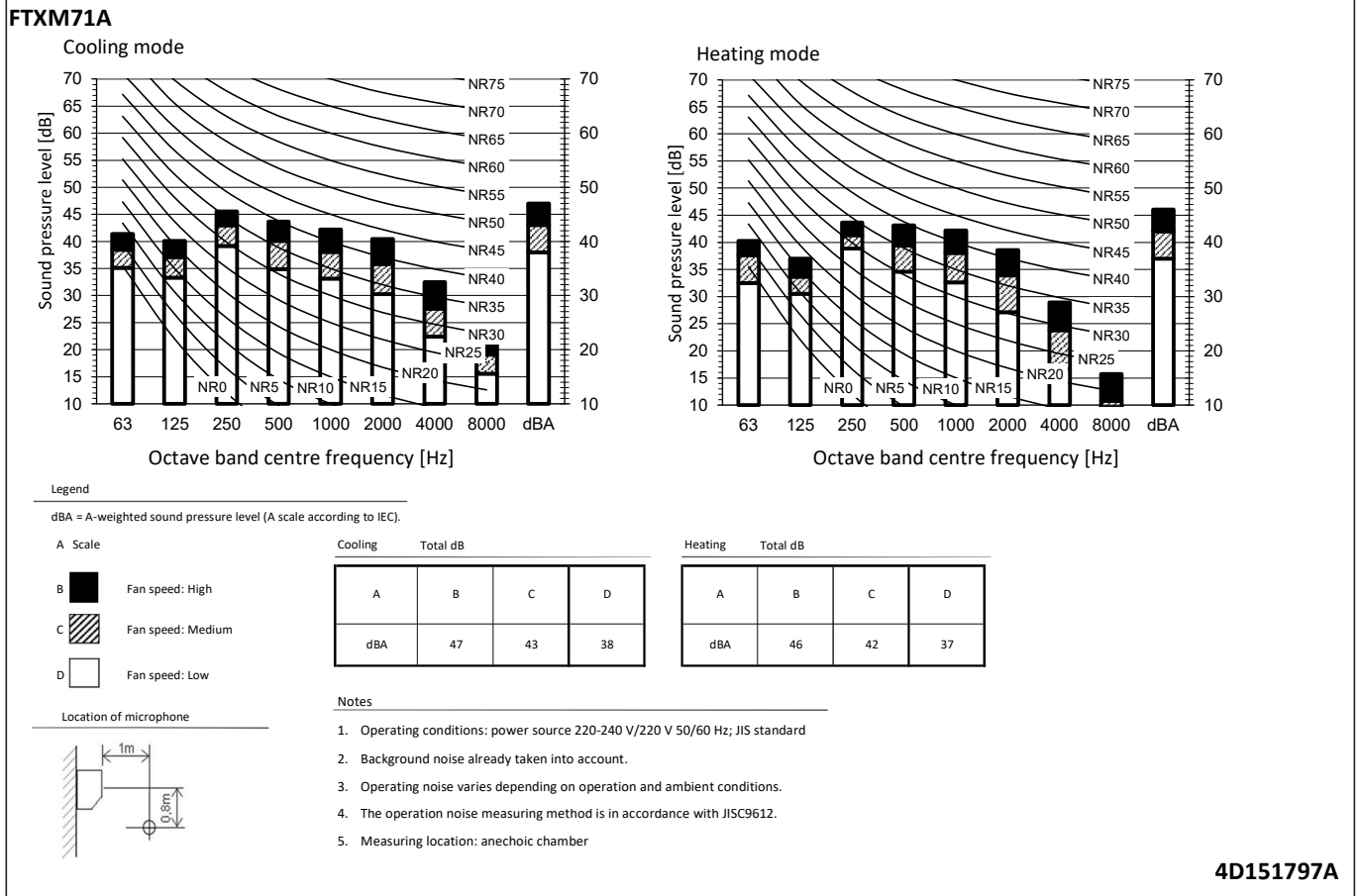

---

**Daikin Europe N.V.** Naamloze Vennootschap · Zandvoordestraat 300 · 8400 Oostende · Belgium · [www.daikin.eu](http://www.daikin.eu) · BE 0412 120 336 · RPR Oostende (Responsible Editor)

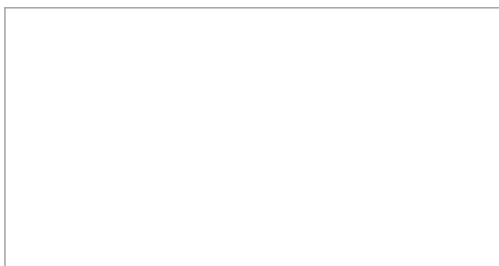

Daikin Europe N.V. participates in the ECP programmes for Fan Coil Units and Variable Refrigerant Flow systems; Daikin Applied Europe S.p.A. participates in the ECP programmes for Liquid Chilling Packages and Hydronic Heat Pumps. Check ongoing validity of certificate: [www.eurovent-certification.com](http://www.eurovent-certification.com)

EEEN25

09/2025



The present leaflet is drawn up by way of information only and does not constitute an offer binding upon Daikin Europe N.V. Daikin Europe N.V. has compiled the content of this leaflet to the best of its knowledge. No express or implied warranty is given for the completeness, accuracy, reliability or fitness for particular purpose of its content and the products and services presented therein. Specifications are subject to change without prior notice. Daikin Europe N.V. explicitly rejects any liability for any direct or indirect damage, in the broadest sense, arising from or related to the use and/or interpretation of this leaflet. All content is copyrighted by Daikin Europe N.V.