

Contents

Safety precautions.....	3
Preparation for outdoor unit installation.....	5
Deciding on where to install the outdoor unit.....	6
Selecting installation location.....	10
Base construction and installation of the outdoor unit.....	11
Connecting the cable.....	14
Connecting the refrigerant pipe.....	21
Adding refrigerant (R-410A).....	22
Connecting up and removing air in the circuit.....	24
Cutting/Flaring the pipes.....	25
Performing leak tests.....	26
Connecting the drain hose to the outdoor unit.....	26
Insulation.....	27
Using stop valve.....	28
Pump down Procedure.....	29
Checking correct grounding.....	30
Testing operations.....	31
Troubleshooting.....	33
Extending the power cable.....	36

Safety precautions

Carefully follow the precautions listed below because they are essential to guarantee the safety of the equipment.



WARNING

- Always disconnect the air conditioner from the power supply before servicing it or accessing its internal components.
- Verify that installation and testing operations are performed by qualified personnel.
- Verify that the air conditioner is not installed in an easily accessible area.

General information

- ▶ Carefully read the content of this manual before installing the air conditioner and store the manual in a safe place in order to be able to use it as reference after installation.
- ▶ For maximum safety, installers should always carefully read the following warnings.
- ▶ Store the operation and installation manual in a safe location and remember to hand it over to the new owner if the air conditioner is sold or transferred.
- ▶ This manual explains how to install an indoor unit with a split system with two SAMSUNG units. The use of other types of units with different control systems may damage the units and invalidate the warranty. The manufacturer shall not be responsible for damages arising from the use of non compliant units.
- ▶ The manufacturer shall not be responsible for damage originating from unauthorized changes or the improper connection of electric and requirements set forth in the "Operating limits" table, included in the manual, shall immediately invalidate the warranty.
- ▶ The air conditioner should be used only for the applications for which it has been designed: the indoor unit is not suitable to be installed in areas used for laundry.
- ▶ Do not use the units if damaged. If problems occur, switch the unit off and disconnect it from the power supply.
- ▶ In order to prevent electric shocks, fires or injuries, always stop the unit, disable the protection switch and contact SAMSUNG's technical support if the unit produces smoke, if the power cable is hot or damaged or if the unit is very noisy.
- ▶ Always remember to inspect the unit, electric connections, refrigerant tubes and protections regularly. These operations should be performed by qualified personnel only.
- ▶ The unit contains moving parts, which should always be kept out of the reach of children.
- ▶ Do not attempt to repair, move, alter or reinstall the unit. If performed by unauthorized personnel, these operations may cause electric shocks or fires.
- ▶ Do not place containers with liquids or other objects on the unit.
- ▶ All the materials used for the manufacture and packaging of the air conditioner are recyclable.
- ▶ The packing material and exhaust batteries of the remote controller(optional) must be disposed of in accordance with current laws.
- ▶ The air conditioner contains a refrigerant that has to be disposed of as special waste. At the end of its life cycle, the air conditioner must be disposed of in authorized centers or returned to the retailer so that it can be disposed of correctly and safely.
- ▶ This appliance is not intended for use by persons (including children) with reduced physical, sensory or mental capabilities, or lack of experience and knowledge, unless they have been given supervision or instruction concerning use of the appliance by a person responsible for their safety. Children should be supervised to ensure that they do not play with the appliance.

Safety precautions

Installing the unit

IMPORTANT: When installing the unit, always remember to connect first the refrigerant tubes, then the electrical lines.

Always disassemble the electric lines before the refrigerant tubes.

- ▶ Upon receipt, inspect the product to verify that it has not been damaged during transport. If the product appears damaged, DO NOT INSTALL it and immediately report the damage to the carrier or retailer (if the installer or the authorized technician has collected the material from the retailer.)
- ▶ After completing the installation, always carry out a functional test and provide the instructions on how to operate the air conditioner to the user.
- ▶ Do not use the air conditioner in environments with hazardous substances or close to equipment that release free flames to avoid the occurrence of fires, explosions or injuries.
- ▶ Our units should be installed in compliance with the spaces shown in the installation manual, to ensure accessibility from both sides and allow repairs or maintenance operations to be carried out. The unit's components should be accessible and easy to disassemble without endangering people and objects.

For this reason, when provisions of the installation manual are not complied with, the cost required to access and repair the units (in SAFETY CONDITIONS, as set out in prevailing regulations) with harnesses, ladders, scaffolding or any other elevation system will NOT be considered part of the warranty and will be charged to the end customer.

Power supply line, fuse or circuit breaker

- ▶ Always make sure that the power supply is compliant with current safety standards. Always install the air conditioner in compliance with current local safety standards.
- ▶ Always verify that a suitable grounding connection is available.
- ▶ Verify that the voltage and frequency of the power supply comply with the specifications and that the installed power is sufficient to ensure the operation of any other domestic appliance connected to the same electric lines.
- ▶ Always verify that the cut-off and protection switches are suitably dimensioned.
- ▶ Verify that the air conditioner is connected to the power supply in accordance with the instructions provided in the wiring diagram included in the manual.
- ▶ Always verify that electric connections (cable entry, section of leads, protections...) are compliant with the electric specifications and with the instructions provided in the wiring scheme. Always verify that all connections comply with the standards applicable to the installation of air conditioners.
- ▶ Devices disconnected from the power supply should be completely disconnected in the condition of overvoltage category.
- ▶ Be sure not to perform power cable modification, extension wiring, and multiple wire connection.
 - It may cause electric shock or fire due to poor connection, poor insulation, or current limit override.
 - When extension wiring is required due to power line damage, refer to "Step 2.4 Optional: Extending the power cable" in the installation manual.

Preparation for outdoor unit installation

The air conditioner uses R-410A refrigerant.

A Type: AC160JXADGH & AC180JXAPNH

■ Heat pump

(Unit : mm)

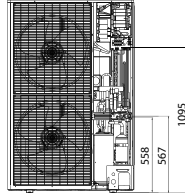
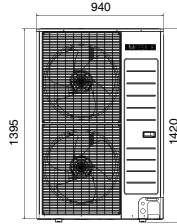
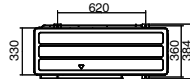

Model	Net weight	Net dimension (W*D*H)
AC160JXADGH	96.0 kg	940*330*1420 mm
AC180JXAPNH	107.5 kg	940*330*1420 mm

B Type: AC200KXAPNH / AC250KXAPNH

■ Heat pump

(Unit : mm)

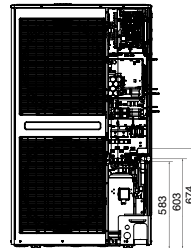
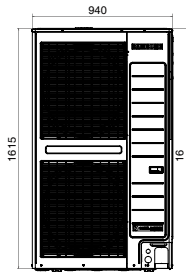
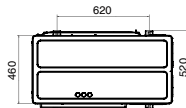
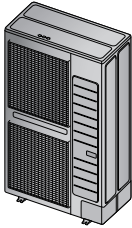

Model	Net weight	Net dimension (W*D*H)
AC200KXAPNH	154 kg	940*460*1630 mm
AC250KXAPNH	154 kg	940*460*1630 mm

Preparation for outdoor unit installation

Moving the Outdoor Unit by Wire Rope

Fasten the outdoor unit by two 8m or longer wire ropes as shown at the figure. To prevent from damage or scratches, insert a piece of cloth between the outdoor unit and rope, then move the unit.

- * The appearance of the unit may be different from the picture depending on the model.

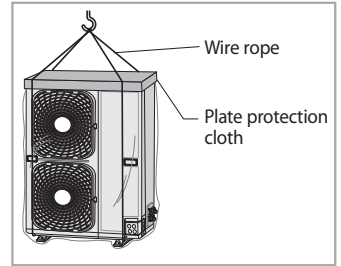

Deciding on where to install the outdoor unit

Outdoor Unit

- ◆ The outdoor unit must not be placed on its side or upside down, as the compressor lubrication oil will run into the cooling circuit and seriously damage the unit.
- ◆ Choose a location that is dry and sunny, but not exposed to direct sunlight or strong winds.
- ◆ Do not block any passageways or thoroughfares.
- ◆ Choose a location where the noise of the air conditioner when running and the discharged air do not disturb any neighbours.
- ◆ Choose a position that enables the pipes and cables to be easily connected to the indoor unit.
- ◆ Install the outdoor unit on a flat, stable surface that can support its weight and does not generate any unnecessary noise and vibration.
- ◆ Position the outdoor unit so that the air flow is directed towards the open area.
- ◆ Maintain sufficient clearance around the outdoor unit, especially from a radio, computer, stereo system, etc.

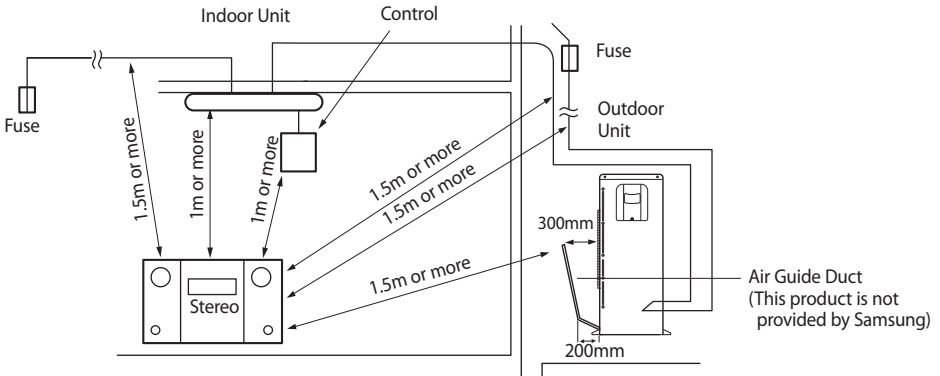

Deciding on where to install the outdoor unit

- ◆ If the outdoor unit is installed at a height, ensure that its base is firmly fixed in position.
- ◆ Make sure that the water dripping from the drain hose runs away correctly and safely.
- ◆ When you install the outdoor unit at wayside, you should install it above 2m height or make sure that the heat from the outdoor unit shouldn't be in direct contact with passersby. (The ground for application :The revision of regulation for facility in building by the law of the Ministry of Construction and Transportation.



- You have just purchased a system air conditioner and it has been installed by your installation specialist.
- This device must be installed according to the national electrical rules.
- With an outdoor unit having net weight upper than 60kg, we suggest do not install it suspended on wall, but considering floor standing one.

- ◆ When installing the outdoor unit near seashore, make sure it is not directly exposed to sea breeze. If you can not find a adequate place without direct see breeze, protection wall should be constructed.

- ▶ Install the outdoor unit in a place (such as near buildings etc.) where it can be prevented from sea breeze which can damage the outdoor unit.

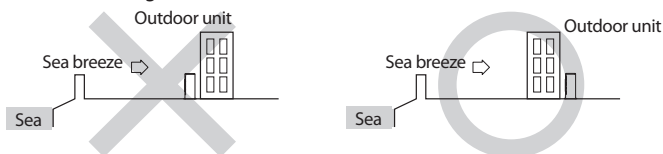

- ▶ If you cannot avoid installing the outdoor unit by the seashore, construct a protection wall around to block the sea breeze.

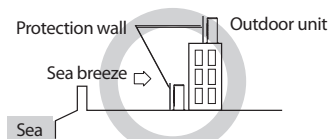

- Protection wall should be constructed with a solid material such as concrete to block the sea breeze and the height and the width of the wall should be 1.5 times larger than the size of the outdoor unit. Also, secure over 700mm between the protection wall and the outdoor unit for exhausted air to ventilate.

- ▶ Install the outdoor unit in a place where water can drain smoothly.

- * If you cannot find a place satisfying above conditions, please contact manufacturer. Make sure to clean the sea water and the dust on the outdoor unit heat exchanger and spread corrosion inhibitor on heat exchanger. (At least one time per one year.)
- * Depending on the condition of power supply, unstable power or voltage may cause malfunction of the parts or control system.(At the ship or places using power supply from electric generator, etc).

! WARNING

- Should adopt bar type louver. Don't use a type of rain resistance louver.

[Bar type louver]



[Rain resistance louver]

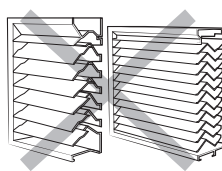

- Louver specifications.
 - Angle criteria : less than 20°
 - Opening ratio criteria : greater than 80%

Deciding on where to install the outdoor unit

Space Requirements for Outdoor Unit

When installing 1 outdoor unit

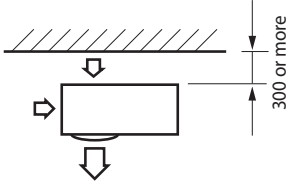

* When the air outlet is opposite the wall

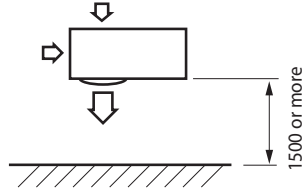

* When the air outlet is towards the wall

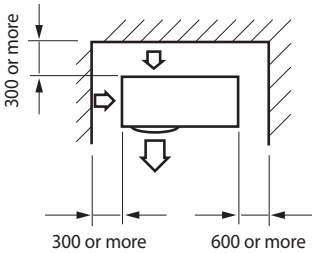

* When 3 sides of the outdoor unit are blocked by the wall

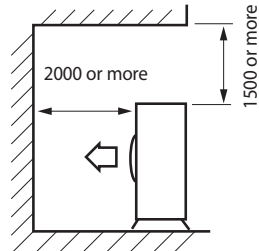

* The upper part of the outdoor unit and the air outlet is towards the wall

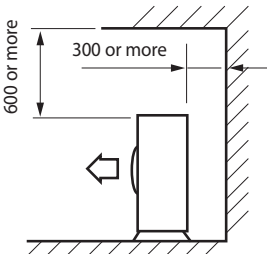

* The upper part of the outdoor unit and the air outlet is opposite the wall

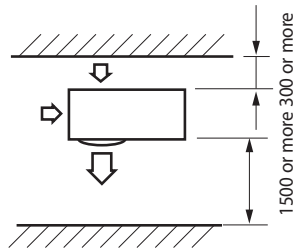

* When front and rear side of the outdoor unit is towards the wall

When installing more than 1 outdoor unit

(Unit : mm)

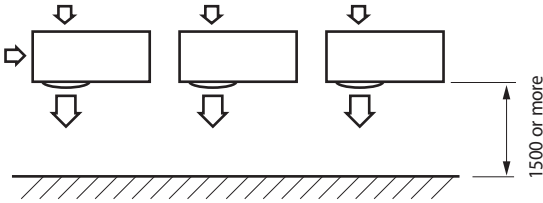

* When the air outlet is towards the wall

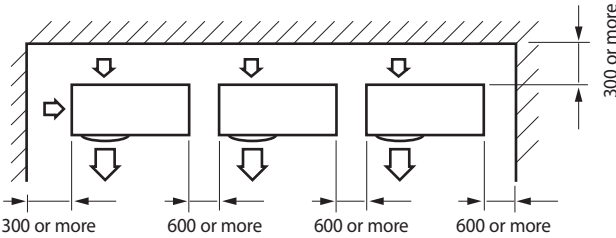

* When 3 sides of the outdoor unit are blocked by the wall

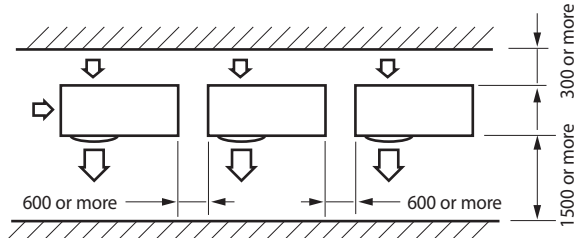

* When front and rear side of the outdoor unit is towards the wall

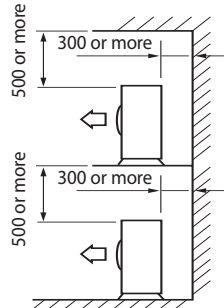

* The upper part of the outdoor unit and the air outlet is towards the wall

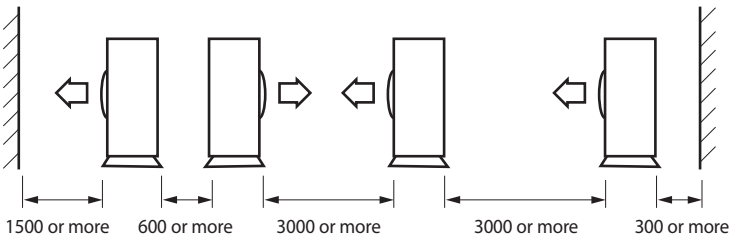

* When front and rear side of the outdoor unit is towards the wall



- The units must be installed according to distances declared, in order to permit accessibility from each side, either to guarantee correct operation of maintenance or repairing products.
The unit's parts must be reachable and removable completely under safety condition (for people or things).

Selecting installation location

Moving the outdoor unit

- ▶ Select the moving path in advance.
- ▶ Be sure that moving path can support weight of the outdoor unit.
- ▶ Do not slant the product more than 30° when carrying it. (Do not lay the product down in sideways.)
- ▶ Surface of the heat exchanger is sharp. Be careful not to get injured while moving the product.



CAUTION

- You must use certain part of the product when moving the product.

1. When moving with a crane

- ▶ Fasten the wire rope as shown in the figure.
- ▶ To protect damage or scratches, insert a piece of cloth between the outdoor unit and the wire rope.

2. When moving with a forklift

- ▶ Carefully insert the forklift forks into the forklift holes at the bottom of the outdoor unit.
- ▶ Be careful with the forklift from damaging the product.

3. When moving the product without wooden pallet and the crane is not available for use

- ▶ Connect a wire rope to the outdoor unit as you would move it with a crane.
- ▶ Hang the wire rope to the forklift fork to move the outdoor unit.

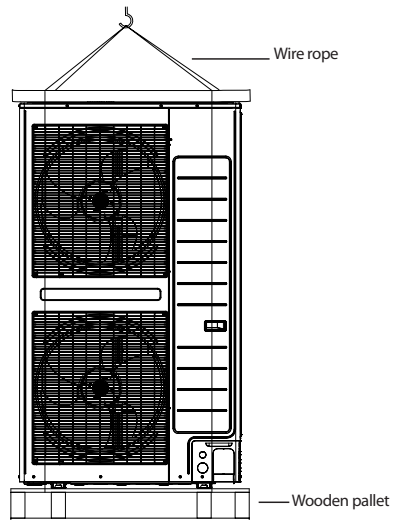

Base construction and installation of the outdoor unit

Installation of outdoor unit



- Make sure to remove the wooden pallet before installing the outdoor unit. If you do not remove the wooden pallet, there is risk of fire during welding the pipes.
- If the outdoor unit is installed with wooden pallet on, and it was used for long period time, wooden palette may break and cause electrical hazard or high pressure may damage the pipes.

1. Install the outdoor unit 150mm higher than the base ground and install the drain hole to connect the pipe to the drainage.
2. When the front fan of an outdoor unit is installed in a place where the average snowfall is more than 150mm, the discharge duct should be attached to the outdoor unit.
3. The concrete foundation should be 1.5 times larger than bottom of the outdoor unit.
4. It is necessary to install wire mesh or steel bar when outdoor units are installed on a soft foundation.
5. When installing multiple outdoor units at the same place, install the H beam on the base ground. (When installing a number of outdoor units, you can install it on the base ground.)
6. Install the H beam(150mm x 150mm x t10 : basic specification) or vibration absorption frame to jut out from the base ground.
7. After installing the H beam, apply corrosion protection.
8. Install a square pad($t=20\text{mm}$ or more) to prevent vibration from the outdoor unit onto the base ground. Place the outdoor unit on the H beam and fix it with the bolt, nut and washer. (Fix with M10 basic anchor bolt, nut and washer.)

Unit: mm

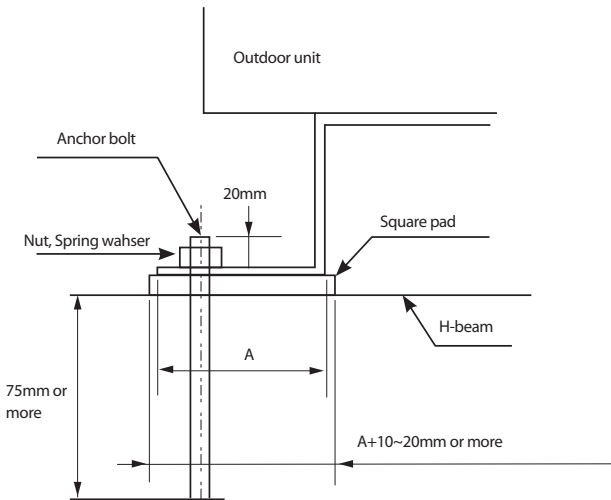

Base construction and installation of the outdoor unit

Base ground construction

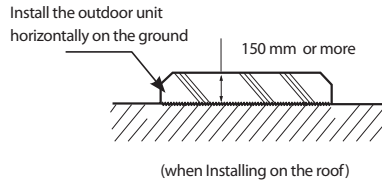
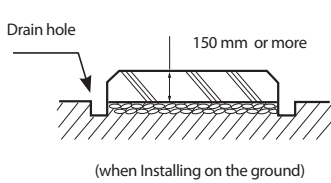

- ▶ The outdoor unit should be supported within the range of measurement below for base ground work.

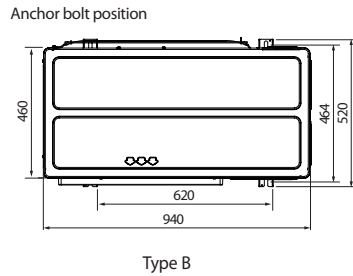
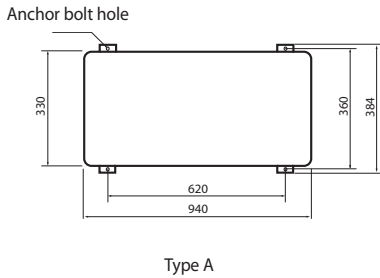

- ▶ When the outdoor unit needs to be supported, fix it with wire as shown in the picture.
 - Slightly unwind the four screws on the cover top of the outdoor unit.
 - Wind wires round the four screws and fasten the screws again.
 - Fix the wires to the ground.

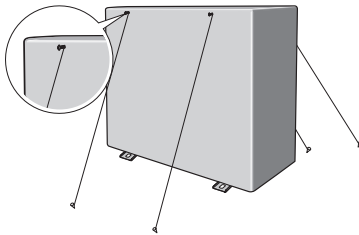

- If the outdoor unit is not fixed securely, product may fall and it might cause loss of life or property damage.
- Do not install the outdoor unit on the wooden pallet.
- Fix the outdoor unit securely to the base ground with anchor bolts.
- The manufacturer is not responsible for the damage occurred by not adhering to the standard of the installation.
- To protect the outdoor unit from external condition such as rain, install it on the base ground and connect the drain pipe to the drainage.



- Please firstly ensure the strength and levelness of the platform, ground and the support so as to lower the noise and vibration for fear of human injuries.
- The hanging mount on the wall is prohibited due to the heavy machine. The improper installation shall lead to the fall of the machine as well as human injuries.

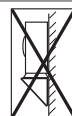

<The machine shall be installed on the ground or on the high platform>

- ▶ As shown in Figure 1, to ensure the shadow part is on the bearing surface without suspension.
- ▶ As shown in Figure 1, the four installation footings shall be firmly fastened on the base platform by the bolts (preparing four sets of M10 bolts with fitful nuts and washer which are used on site)
- ▶ In order to reduce the vibration of the noisemeter, the vibration absorber (offer on site) shall be used between the contact of machine and base platform.
- ▶ It is optimal that anchor bolt is 20mm above the surface. (See Figure 2)

The base of the outdoor unit and the position of foundation bolts

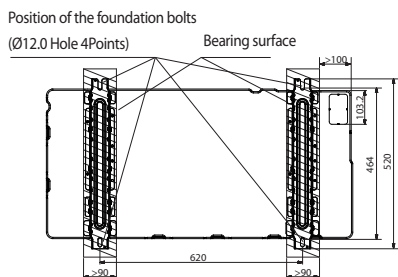

Figure 1

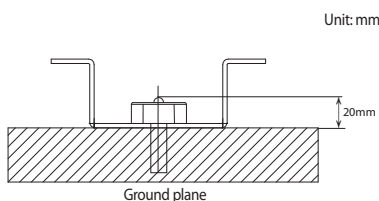
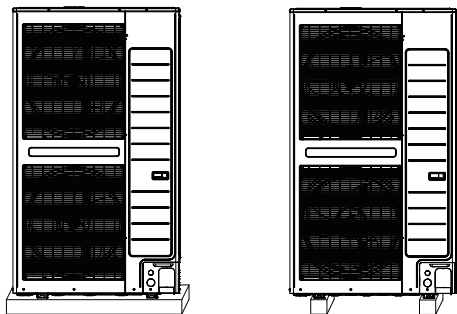

Figure 2

- ▶ Please ensure the shadow part in Figure 1 is really installed on the bearing surface without any suspension.
- ▶ The ground base that is larger than the standing leg of the air-conditioner (90mm in width and 520mm in length) shall be used to support the air-conditioner (See Figure 1), and the rubber mat shall be fully placed on the whole bearing surface.
- ▶ The base platform shall be at least 150mm above the ground.



- When the grounding pipe comes out from the below, please reserve the place for the connection pipe.
- The installation mode mentioned above shall ensure that the shadow part in Figure 1 is really on the installation surface.

Connecting the cable

Two electronic cables must be connected to the outdoor unit.

- ◆ The connection cord between indoor unit and outdoor unit.
- ◆ The power cable between outdoor unit and auxiliary circuit breaker.
- ◆ Specially for Russian and European market, before installation, the supply authority should be consulted to determine the supply system impedance to ensure compliance.



- During the unit installation make first refrigerant connections and then electrical connections. If unit is uninstalled first disconnect electrical cables, then refrigerant connections.
- Connect the air conditioner to grounding system before performing the electrical connection.
- When installing the unit, you shouldn't use inter connection wire.

Example of Air Conditioner System

When using ELCB for 1 phase

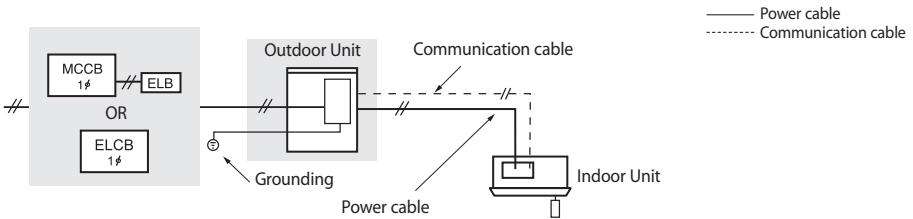

When using ELCB for 3 phase 4 wires

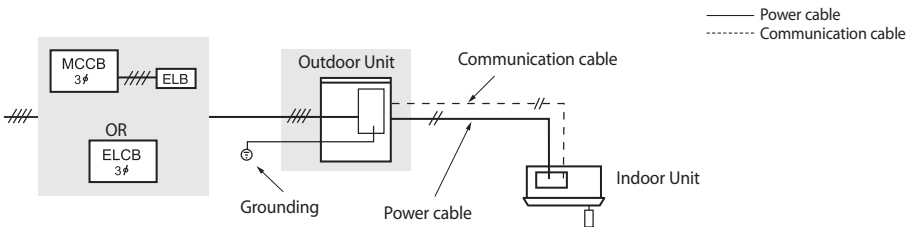

When using ELCB for 3 phase 4 wires

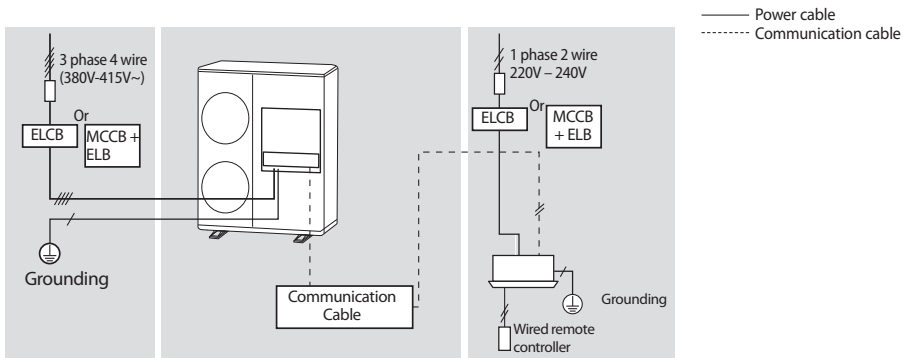

* If an outdoor unit is installed in a place in danger of an electric leak or submergence, you must install the ELCB.

Power Cable Specifications

- ◆ The power cable is not supplied with air conditioner.
 - Select the power supply cable in accordance with relevant local and national regulations.
 - Wire size must comply with the applicable local and national code.
 - Specifications for local wiring power cord and branch wiring are in compliance with local cord.

3 Phase

Type of outdoor unit	Model		Outdoor Units				Input Current [A]				Power Supply	
	Outdoor Unit	Indoor Unit	Rated		Voltage Range		Outdoor (Down_Amp)		Indoor	Total	MCA	MFA
			Hz	Volts	Min.	Max.	Cooling	Heating				
A	AC160JXADGH	AC160JNCDEH	50	380-415	342	456.5	12	12	2.7	14.7	14.7	16.2
	AC180JXAPNH	AC180JNHPKH	50	380-415	342	456.5	16.1	16.1	2.5	18.6	18.6	20.46
B	AC200KXAPNH	AC200KNHPKH	50	380-415	342	456.5	-	-	-	-	25.0	31.25
	AC250KXAPNH	AC250KNHPKH	50	380-415	342	456.5	-	-	-	-	25.0	31.25



NOTE

1. Voltage range

- Units are suitable for use on electrical systems where voltage supplied to unit terminal is not below or above listed range limits

2. Maximum allowable voltage variation between phases is 2%.

3. Wire size & type must comply with the applicable local and national code.

- Wire size : Based on the value of MCA.

- Wire type : 60245 IEC57(IEC) or H05RN-F(CENELEC) grade or more.

4. MFA is used to select the circuit breaker and the ground fault circuit interrupter (earth leakage circuit breaker).

5. MCA represents maximum input current.

MFA represents capacity which may accept MCA

* Abbreviations

- MCA : Min. Circuit Amps. (A)

- MFA : Max. Fuse Amps. (A)

6. This equipment complies with IEC 61000-3-12 provided that the short-circuit power S_{sc} is greater than or equal to $S_{sc}^{(*)2}$ at the interface point between the user's supply and the public system. It is the responsibility of the installer or user of the equipment to ensure, by consultation with the distribution network operator if necessary, that the equipment is connected only to a supply with a short-circuit power S_{sc} greater than or equal to $S_{sc}^{(*)2}$.
[$S_{sc}^{(*)2}$]

Model	S_{sc} [MVA]
AC160JXADGH	0.725
AC180JXAPNH	2.944
AC200KXAPNH	2.459
AC250KXAPNH	4.139

Connecting the cable

Between Indoor unit and Outdoor unit Connection Cable Specifications(Common in use)

Power supply			Communcation Cable
Power supply	Max/Min(V)	Indoor Power Cable	
1Φ, 220-240V, 50Hz	±10%	2.5mm ² ↑, 3wires	0.75~1.5mm ² , 2wires

- ◆ Power supply cords of parts of appliances for outdoor use shall not be lighter than polychloroprene sheathed flexible cord. (Code designation IEC:60245 IEC 57 / CENELEC: H05RN-F or IEC:60245 IEC 66 / CENELEC: H07RN-F)

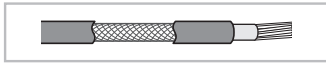

When installing the indoor unit in a computer room or net work room, use the double shielded (Tape aluminum / polyester braid + copper) cable of FROHH2R type.

1-phase terminal block spec

AC power : M5 screw

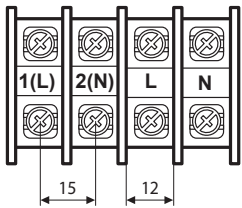

Communication : M4 screw

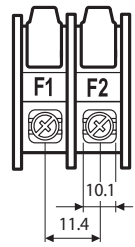

Communication : M3 screw

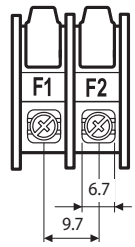

3-phase terminal block spec

AC power : M4 screw

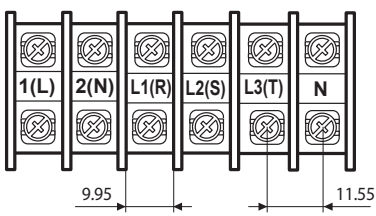

Communication : M4 screw

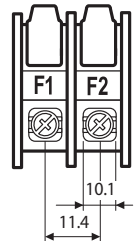

Communication : M3 screw

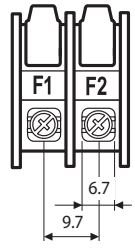

3-phase terminal block spec (AC***KXAPNH)

AC power : M6 screw

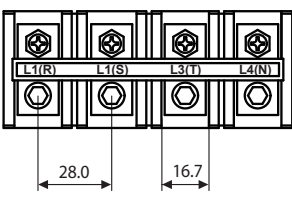

Communication : M4 screw

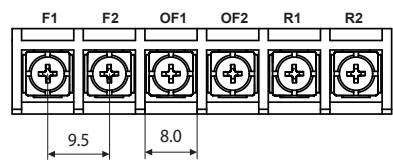

Wiring Diagram of Power Cable

When using ELCB for 1 phase

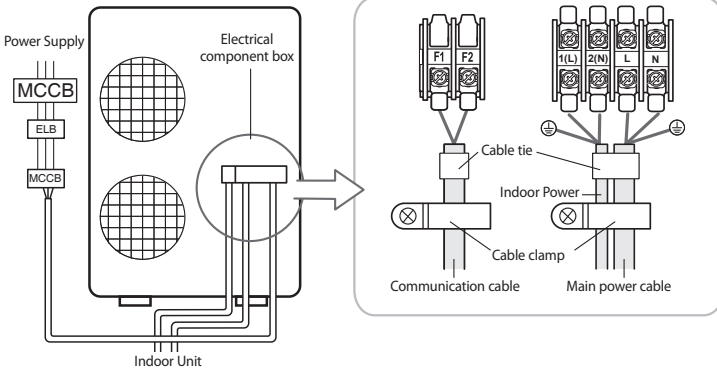

* The appearance of the unit may be different from the picture depending on the model.

When using ELCB for 3 phase 4 wires (AC***JXAPNH)

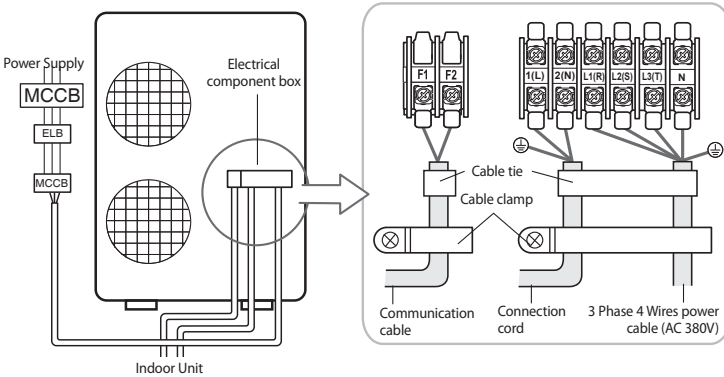

* The appearance of the unit may be different from the picture depending on the model.

When using ELCB for 3 phase 4 wires (AC***KXAPNH)

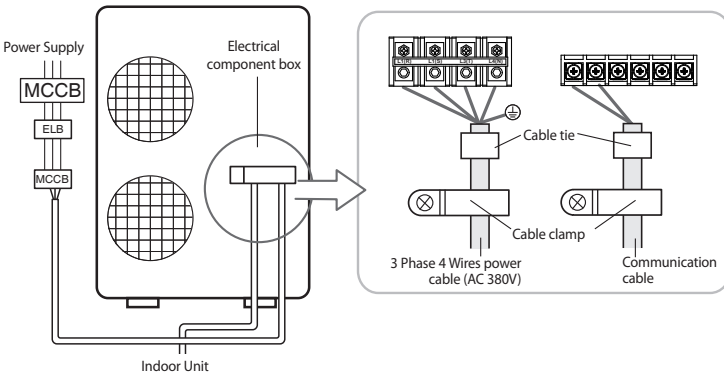

* The appearance of the unit may be different from the picture depending on the model.

Connecting the cable



- You should connect the power cable into the power cable terminal and fasten it with a clamp.
- The unbalanced power must be maintained within 2% of supply rating.
 - If the power is unbalanced greatly, it may shorten the life of the condenser. If the unbalanced power is exceeded over 4% of supply rating, the indoor unit is protected, stopped and the error mode indicates.
- To protect the product from water and possible shock, you should keep the power cable and the connection cord of the indoor and outdoor units within ducts. (with appropriate IP rating and material selection for your application)
- Ensure that main supply connection is made through a switch that disconnects all poles, with contact gap of a least 3 mm.
- Devices disconnected from the power supply should be completely disconnected in the condition of overvoltage category.
- Keep distances of 50mm or more between power cable and communication cable.

Wiring Diagram of Connection Cord

1 phase

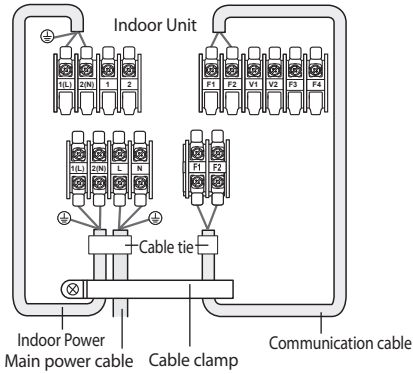

3 phase(*160/180*)

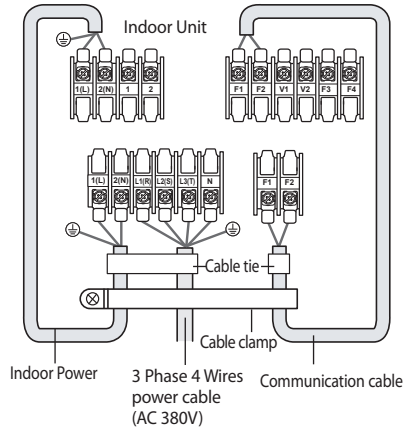

3 phase(*200/250*)

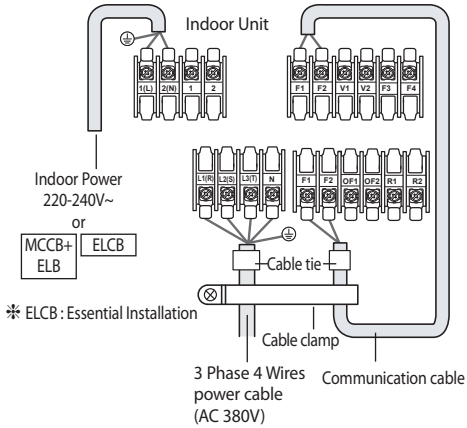

- Lay the electrical wiring so that the front cover does not rise up when doing wiring work and attach the front cover securely.
- Ground wire for the indoor unit and outdoor unit connection cable must be clamped to a soft copper tin-plated eyelet terminal with M4 screw hole (NOT SUPPLIED WITH UNIT ACCESSORIES).

Connecting the cable

Connecting the Power Terminal

- ◆ Connect the cables to the terminal board using the compressed ring terminal.
- ◆ Cover a solderless ring terminal and a connector part of the power cable and then connect it.

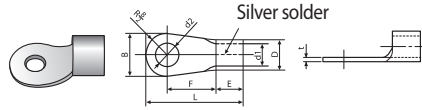

Nominal dimensions for cable [mm ² (inch ²)]	Nominal dimensions for screw [mm(inch)]	B		D		d1		E			F			L			d2		t [mm (inch)]
		Standard dimension [mm(inch)]	Allowance [mm(inch)]	Standard dimension [mm(inch)]	Allowance [mm(inch)]	Standard dimension [mm(inch)]	Allowance [mm(inch)]	Min. [mm (inch)]	Min. [mm (inch)]	Max. [mm (inch)]	Standard dimension [mm(inch)]	Allowance [mm(inch)]	Min. [mm (inch)]						
4/6 (0.006/ 0.009)	4(3/8)	9.5(3/8)	±0.2 (±0.007)	5.6(1/4)	+0.3(+0.011) -0.2(-0.007)	3.4(1/8)	±0.2 (±0.007)	6 (1/4)	5 (3/16)	20 (3/4)	4.3 (3/16)	+0.2(+0.007) 0(0)	0.9 (0.03)						
	8(3/16)	15(9/16)												8.4 (1-3/16)	+0.4(+0.015) 0(0)				
10(0.01)	8(3/16)	15(9/16)	±0.2 (±0.007)	7.1(1/4)	+0.3(+0.011) -0.2(-0.007)	4.5(3/16)	±0.2 (±0.007)	7.9 (5/16)	9 (3/8)	30 (1-3/16)	8.4 (1-3/16)	+0.4(+0.015) 0(0)	1.15 (0.04)						
16(0.02)	8(3/16)	16(10/16)	±0.2 (±0.007)	9(3/8)	+0.3(+0.011) -0.2(-0.007)	5.8(1/4)	±0.2 (±0.007)	9.5 (5/16)	13 (1/2)	33 (1-5/16)	8.4 (1-3/16)	+0.4(+0.015) 0(0)	1.45 (0.05)						
25(0.03)	8(3/16)	12(1/2)	±0.3 (±0.011)	11.5(7/16)	+0.5(+0.019) -0.2(-0.007)	7.7(5/16)	±0.2 (±0.007)	11 (3/8)	15 (5/8)	34 (1-3/8)	8.4 (1-3/16)	+0.4(+0.015) 0(0)	1.7 (0.06)						
	8(3/16)	16.5(10/16)												8.4 (1-3/16)					
35(0.05)	8(3/16)	16(10/16)	±0.3 (±0.011)	13.3(1/2)	+0.5(+0.019) -0.2(-0.007)	9.4(3/8)	±0.2 (±0.007)	12.5 (1/2)	13 (1/2)	38 (1-1/2)	8.4 (1-3/16)	+0.4(+0.015) 0(0)	1.8 (0.07)						
	8(3/16)	22(7/8)												8.4 (1-11/16)					
50(0.07)	8(3/16)	22(7/8)	±0.3 (±0.011)	13.5(1/2)	+0.5(+0.019) -0.2(-0.007)	11.4(7/16)	±0.3 (±0.011)	17.5 (11/16)	14 (9/16)	50 (2)	8.4 (1-3/16)	+0.4(+0.015) 0(0)	1.8 (0.07)						
70(0.10)	8(3/16)	24(1)	±0.4 (±0.015)	17.5(11/16)	+0.5(+0.019) -0.4(-0.015)	13.3(1/2)	±0.4 (±0.015)	18.5 (3/4)	20 (3/4)	51 (2)	8.4 (1-3/16)	+0.4(+0.015) 0(0)	2.0 (0.078)						

- ◆ Connect the rated cables only.
- ◆ Connect using a driver which is able to apply the rated torque to the screws.
- ◆ If the terminal is loose, fire may occur caused by arc. If the terminal is connected too firmly, the terminal may be damaged.

Tightening Torque (kgf · cm)		
M3	5.0~7.5	Communication : F1, F2
M4	12.0~18.0	3phase AC power : 1(L), 2(N), L1(R), L2(S), L3(T), N
M5	20.0~30.0	1phase AC power : 1(L), 2(N), L, N



- When connecting cables, you can connect the cables to the electrical part or connect them through the holes below depending on the spot.
- **Run transmission wiring between the indoor and outdoor units through a conduit to protect against external forces, and feed the conduit through the wall together with refrigerant piping.**
- Remove all burrs at the edge of the knock-out hole and secure the cable to the outdoor knock-out using lining and bushing with an electrical insulation such as rubber and so on.
- Must keep the cable in a protection tube.
- Keep distances of 50mm or more between power cable and communication cable.
- When the cables are connected through the hole, remove the Plate bottom.

Connecting the refrigerant pipe

Refrigerant piping system

Items	Maximum allowable length
	Single installation
Applicable outdoor unit models	AC160JXADGH AC180JXAPNH AC200KXAPNH AC250KXAPNH
Main pipe (L ₁)	75 m
Max. height difference between outdoor and indoor units (h ₁)	30 m

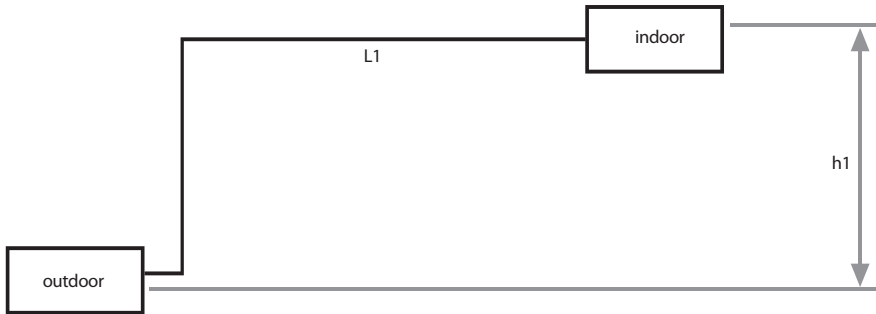

◆ Temper grade and minimum thickness of the refrigerant pipe

Outer diameter [mm]	Minimum thickness [mm]	Temper grade
ø6.35	0.7	C1220T-O
ø9.52	0.7	
ø12.70	0.8	
ø15.88	1.0	
ø15.88	0.8	C1220T-1/2H OR C1220T-H
ø19.05	0.9	
ø22.23	0.9	



- Make sure to use C1220T-1/2H (Semi-hard) pipe for more than ø19.05mm. In case of using C1220T-O (Soft) pipe for ø19.05mm, pipe may be broken, which can result in an injury.

Connecting the refrigerant pipe

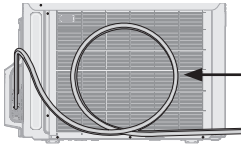

Make at least one round:
It will reduce noise and vibration

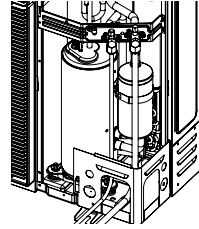

* The appearance of the unit may be different from the diagram depending on the model.



- After connecting pipes with knock-out treatment, plug the space.
- Following the pipe connection, make sure to proceed precisely to prevent interference with the internal parts.



Caution for welding the pipe to an outdoor unit (Only for AC***KXAPNH):

- When welding the pipe, the unit may get damaged by the heat and flame from welding. Specifically outdoor's pipe near by EEV, the fire would damage the EEV. Use a flame proofing cloth to protect the unit from a welding fire or flame.
- The O-ring and Teflon packing inside service valve may get damaged by the heat from welding. Wrap the bottom side of the service valve with a wet cloth and weld it as shown in the illustration. Also, water dripping from the wet cloth may interrupt the welding. Make sure the water does not drip from the wet cloth.
- Make sure that connected pipes does not interrupt each other or make contact with the product. (Vibration may cause damage to the pipes.)

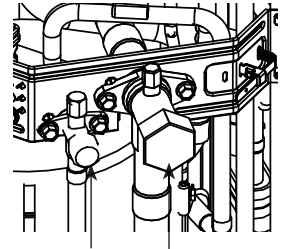

High pressure (Liquid side) Low pressure (Gas side)

Adding refrigerant (R-410A)

The outdoor unit is loaded with sufficient refrigerant for the standard piping. Thus, refrigerant must be added if the piping is lengthened. This operation can only be performed by a qualified refrigeration specialist. For quantity of adding refrigerant, refer to page 23.

1. Check that the stop valve is closed entirely.
2. Charge the refrigerant through the service port of liquid stop valve.



- Do not charge the refrigerant through the gas side service port.

3. If you cannot charge the refrigerant according to the upper steps, following these :
 - 1) Open both liquid stop valve and gas stop valve.
 - 2) Operate the air conditioner by pressing the K2 key on the outdoor unit PCB.
 - 3) About 30 minutes later, charge the refrigerant through the service port of gas stop valve.



- If necessary, refer to the pressure table classified by outdoor temperature.

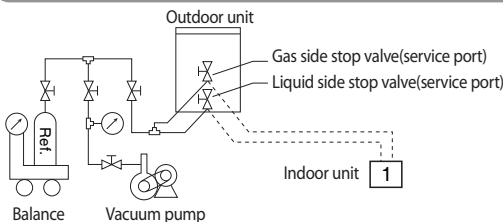

Adding refrigerant (R-410A)

How to Calculate the Quantity of Adding Refrigerant

The quantity of additional refrigerant is variable according to the installation situation. Thus, make sure the outdoor unit situation before adding refrigerant. This operation can only be performed by a qualified refrigeration specialist.

Single installation outdoor unit

Model	Interconnection pipe length (m)					
	0~30	30~40	40~50	50~60	60~70	70~75
AC160JXADGH AC180JXAPNH AC200KXAPNH AC250KXAPNH	0	+50g/m over 30m				

Connecting up and removing air in the circuit



- When installing, make sure there is no leakage. When recovering the refrigerant, ground the compressor first before removing the connection pipe. If the refrigerant pipe is not properly connected and the compressor works with the service valve open, the pipe inhales the air and it makes the pressure inside of the refrigerant cycle abnormally high. It may cause explosion and injury.

The air in the indoor unit and in the pipe must be purged. If air remains in the refrigeration pipes, it will affect the compressor either reduce cooling/heating capacity or lead to a malfunction. Refrigerant for air purging is not charged in the outdoor unit. Use Vacuum Pump as shown at the right figure.

1. Connect each assembly pipe to the appropriate valve on the outdoor unit and tighten the flare nut.
2. Referring to the illustration opposite, tighten the flare nut on section B first manually and then with a torque wrench, applying the following torque.

Outer Diameter (D)	Torque (N·m)
ø6.35 mm(1/4")	14~18
ø9.52 mm(3/8")	34~42
ø12.70 mm(1/2")	49~61
ø15.88 mm(5/8")	68~82
ø19.05 mm(3/4")	100~120

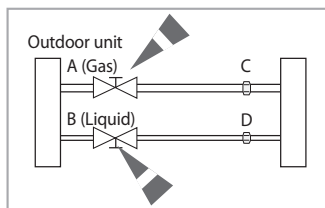

3. Connect the charging hose of low pressure side of manifold gauge to the packed valve having a service port as shown at the figure.



- Make the electrical connection and leave the system into "stand by mode". Do not turn on the system. This is necessary to speed up vacuum operation (full OPEN position of Electronic Expansion Valve - EEV -).

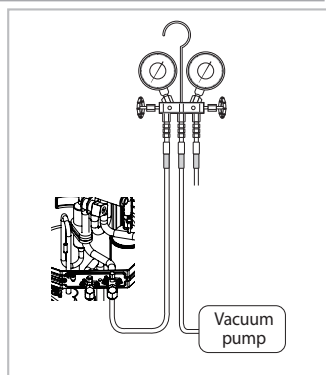

* The designs and shape are subject to change according to the model.

4. Open the valve of the low pressure side(A) of manifold gauge counterclockwise.
5. Purge the air from the system using vacuum pump for about 10 minutes.
 - ◆ Close the valve of the low pressure side of manifold gauge clockwise.
 - ◆ Make sure that pressure gauge shows -0.1MPa(-76cmHg) after about 10 minutes. This procedure is very important to avoid a gas leak.
 - ◆ Turn off the vacuum pump.
 - ◆ Remove the hose of the low pressure side of manifold gauge.
6. Set valve cork of both liquid side and gas side of packed valve to the open position.
7. Mount the valve stem nuts and the service port cap to the valve, and tighten them at the torque of 183kgf·cm with a torque wrench.
8. Check for gas leakage.
 - ◆ At this time, especially check for gas leakage from the 3-way valve's stem nuts(A port), and from the service port cap.

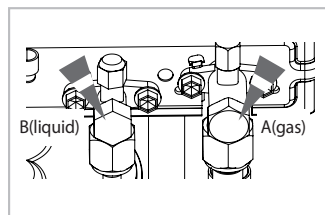

- Connect the indoor and outdoor units using pipes with flared connections (not supplied). For the lines, use insulated, unwelded, degreased and deoxidized copper pipe, (Cu DHP type to ISO 1337 or UNI EN 12735-1), suitable for operating pressures of at least 4200kPa and for a burst pressure of at least 20700kPa. Copper pipe for hydro-sanitary applications is completely unsuitable.
- For sizing and limits (height difference, line length, max. bends, refrigerant charge, etc.) see "Connecting refrigerant pipe section".

Cutting/Flaring the pipes

1. Make sure that you have the required tools available. (pipe cutter, reamer, flaring tool and pipe holder)
2. If you wish to shorten the pipes, cut it with a pipe cutter, taking care to ensure that the cut edge remains at a 90° angle with the side of the pipe. Refer to the illustrations below for examples of edges cut correctly and incorrectly.

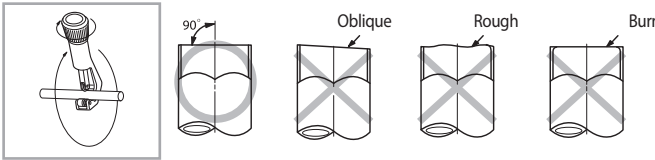

3. To prevent any gas from leaking out, remove all burrs at the cut edge of the pipe, using a reamer.
4. Slide a flare nut on to the pipe and modify the flare.

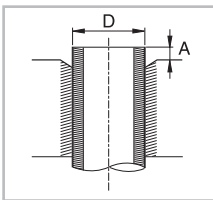

Outer Diameter (D)	Depth (A)
ø6.35 mm (1/4")	1.3 mm
ø9.52 mm (3/8")	1.8 mm
ø12.70 mm (1/2")	2.0 mm
ø15.88 mm (5/8")	2.2 mm
ø19.05 mm (3/4")	2.2 mm

5. Check that the flaring is correct, referring to the illustrations below for examples of incorrect flaring.

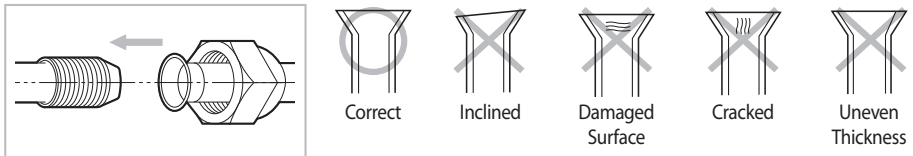

Outer diameter (D, mm)	Connection torque (N·m)	Flare dimension (L, mm)	Flare shape (mm)
ø 6.35	14~18	8.7~9.1	
ø 9.52	34~42	12.8~13.2	
ø 12.70	49~61	16.2~16.6	
ø 15.88	68~82	19.3~19.7	
ø 19.05	100~120	23.6~24.0	



- If the pipes require brazing ensure that OFN(Oxygen Free Nitrogen) is flowing through the system.
- Nitrogen blowing pressure range is 0.02 ~ 0.05MPa.

Performing leak tests

LEAK TEST WITH NITROGEN (before opening valves)

In order to detect basic refrigerant leaks, before recreating the vacuum and recirculating the R-410A, it's responsible of installer to pressurize the whole system with nitrogen (using a cylinder with pressure reducer) at a pressure above 40 bar (gauge).

LEAK TEST WITH R-410A (after opening valves)

Before opening valves, discharge all the nitrogen into the system and create vacuum. After opening valves check leaks using a leak detector for refrigerant R-410A. Once you have completed all the connections, check for possible leaks using leak detector specifically designed for HFC refrigerants.

To check for gas leaks on the Outdoor unit

Then, using a leak detector, check the Valves on sections A and B.

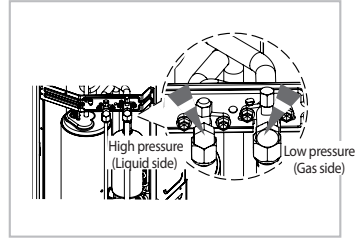

※ The designs and shape are subject to change according to the model.

Connecting the drain hose to the outdoor unit

When using the air conditioner in the heating mode, ice may accumulate. During de-icing (defrost operation), the condensed water must be drained off safely. Consequently, you must install a drain hose on the outdoor unit, following the instructions below.

1. Make space more than 80 mm between the bottom of the outdoor unit and the ground for installation of the drain hose, as shown in figure.
2. Insert the drain plug into the hole on the underside of the outdoor unit.
3. Connect the drain hose to the drain plug.
4. Ensure that the drained water runs off correctly and safely.

AC***JXADGH, AC***JXAPNH

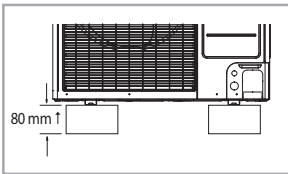

AC***KXAPNH

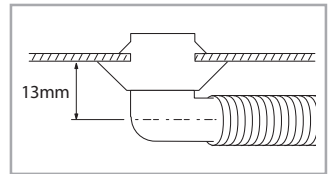
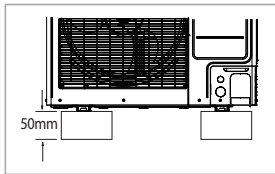

5. Be sure to plug the rest of drain holes not connected with drain plugs using drain caps.

AC***JXADGH, AC***JXAPNH

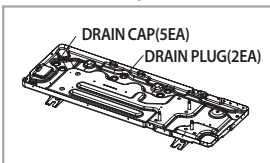

AC***KXAPNH

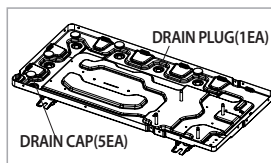

- ※ When installing the product, make sure that the rack is not placed under the drain hole.
- ※ If the product is installed in a region of heavy snow, allow enough separation distance between the product and the ground.

Insulation

Once you have checked that there are no leaks in the system, you can insulate the piping and hose.

1. To avoid condensation problems, place an insulator around each refrigerant pipe.



- When insulate the pipe, be sure to overlap the insulation.
- The insulation has to be produced in full compliance of European regulation reg. EEC / EU 2037/ 2000 that requires the use of sheaths insulation form without using CFC and HCFC gases for health and the environment.



- When insulating the pipe, use non-slit insulator.

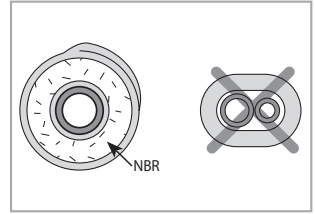

2. Select the insulation of the refrigerant pipe.

- ◆ Insulate the gas side and liquid side pipe referring to the thickness according to the pipe size.
- ◆ Less than Indoor temperature of 30°C and humidity of 85% is the standard condition. If installing in a high humidity condition, use one grade thicker insulator by referring to the table below. If installing in an unfavorable conditions, use thicker one.
- ◆ Insulator's heat-resistance temperature should be more than 120°C.

Pipe	Pipe size	Insulation Type (Heating/Cooling)		Remarks
		Standard [Less than 30°C, 85%]	High humidity [over 30°C, 85%]	
		EPDM, NBR		
Liquid pipe	Ø6.35~Ø9.52	9t	9t	Internal temperature is higher than 120°C
	Ø12.7~Ø19.05	13t	13t	
Gas pipe	Ø6.35	13t	19t	
	Ø9.52~Ø19.05	19t	25t	

- ◆ When installing insulation in places and conditions below, use the same insulation that is used for high humidity conditions.
 - <Geological condition>
 - High humidity places such as shoreline, hot spring, near lake or river, and ridge (when the part of the building is covered by earth and sand.)
 - <Operation purpose condition>
 - Restaurant ceiling, sauna, swimming pool etc.
 - <Building construction condition>
 - The ceiling frequently exposed to moisture and cooling is not covered.
 - e.g. The pipe installed at a corridor of a dormitory and studio or near an exit that opens and closes frequently.
 - The place where the pipe is installed is highly humid due to the lack of ventilation system.

Using stop valve

To Open the Stop Valve

1. Open the cap and turn the stop valve counterclockwise by using a hexagonal wrench.
2. Turn it until the axis is stopped.



- Do not apply excessive force to the stop valve and always use special instruments. Otherwise, the stopping box can be damaged and the back sheet can leak.
- If the watertight sheet leaks, turn the axis back by half, tighten the stopping box, then check the leakage again. If there is no leakage any more, tighten the axis entirely.

3. Tighten the cap securely.

To Close the Stop Valve

1. Remove the cap.
2. Turn the stop valve clockwise by using a hexagonal wrench.
3. Tighten the axis until the valve reached the sealing point.
4. Tighten the cap securely.



- When you use the service port, always use a charging hose, too.
- Check the leakage of refrigerant gas after tightening the cap.
- Must use a spanner and wrench when you open/tighten the stop valve.

- ▶ Before inspecting the leakage, use a torque wrench to close the cap for the service valve. (Comply with a tightening torque for each size of the diameter, and tighten the cap firmly to prevent any leakage.)
- ▶ To check for any possible leakage, inert gas into the pipes connected to indoor/outdoor units and check the connection part of the indoor/outdoor units with soap lather or liquid for leakage test.

Outer diameter (mm)	Tightening torque	
	Body cap (N·m)	Charging port cap (N·m)
Ø6.35	20~25	10~12
Ø9.52	20~25	
Ø12.70	25~30	
Ø15.88	30~35	
Over Ø19.05	35~40	

※ 1 N·m = 10 kgf·cm

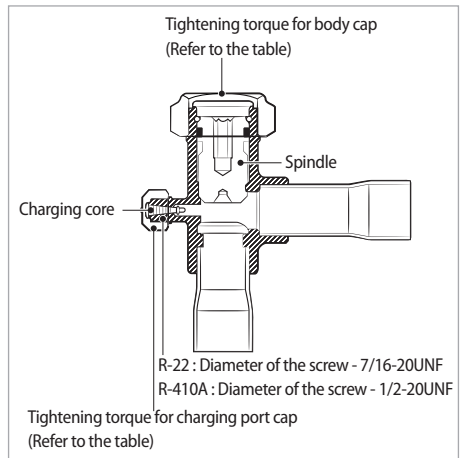

Pump down Procedure

Pump down will be carried out when an evaporator is replaced or when the unit is relocated in another area.

1. Remove the cap from the low pressure side.
2. Turn the low pressure side valve clockwise to close and connect a pressure gauge (low pressure side) to the service valve, and open the valve again.
3. Set the unit to the cooling Test mode by pushing K2 button (Check if the compressor is operating.)
4. Turn the high pressure side valve counter clockwise to close.
5. When the pressure gauge indicates "0" turn the low pressure side valve counter clockwise to close.
6. Stop operation of the air conditioner by pushing K3 button.
7. Close the each cap of valve.

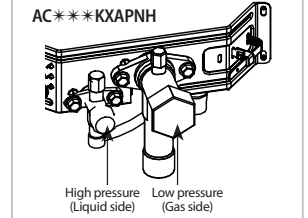
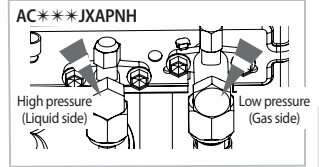

Relocation of the air conditioner

- Refer to this procedure when the unit is relocated.
- Carry out the pump down procedure (refer to the details of 'pump down').
- Remove the power cord.
- Disconnect the assembly cable from the indoor and outdoor units.
- Remove the flare nut connecting the indoor unit and the pipe.
- At this time, cover the pipe of the indoor unit and the other pipe using a cap or vinyl plug to avoid foreign material entering.
- Disconnect the pipe connected to the outdoor unit. At this time, cover the valve of the outdoor unit and the other pipe using a cap or vinyl plug to avoid foreign material entering.
- Make sure you do not bend the connection pipes in the middle and store together with the cables.
- Move the indoor and outdoor units to a new location.
- Remove the mounting plate for the indoor unit and move it to a new location.

Checking correct grounding

If the power distribution circuit does not have a grounding or the grounding does not comply with specifications, an grounding electrode must be installed. The corresponding accessories are not supplied with the air conditioner.

1. Select a grounding electrode that complies with the specifications given in the illustration.
2. Connect the flexible hose to the flexible hose port.
 - ◆ In damp hard soil rather than loose sandy or gravel soil that has a higher grounding resistance.
 - ◆ Away from underground structures or facilities, such as gas pipes, water pipes, telephone lines and underground cables.
 - ◆ At least two metres away from a lightning conductor grounding electrode and its cable.

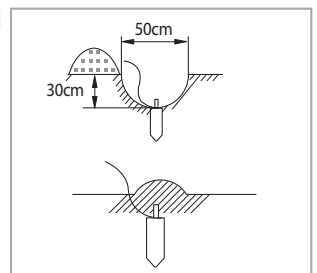
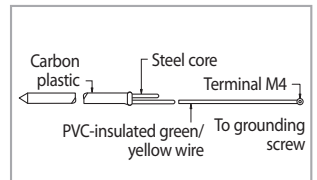

- The grounding wire for the telephone line cannot be used to ground the air conditioner.

3. Finish wrapping insulating tape around the rest of the pipes leading to the outdoor unit.

Checking correct grounding

4. Install a green/yellow coloured grounding wire :

- ◆ If the grounding wire is too short, connect an extension lead, in a mechanical way and wrapping it with insulating tape (do not bury the connection).
- ◆ Secure the grounding wire in position with staples.



• If the grounding electrode is installed in an area of heavy traffic, its wire must be connected securely.

5. Carefully check the installation, by measuring the grounding resistance with a ground resistance tester. If the resistance is above required level, drive the electrode deeper into the ground or increase the number of grounding electrodes.
6. Connect the grounding wire to the electrical component box inside of the outdoor unit.

Testing operations

1. Check the power supply between the outdoor unit and the auxiliary circuit breaker.

- ◆ 1 phase power supply : L, N
- ◆ 3 phases power supply : R,S,T,N

2. Check the indoor unit.

- 1) Check that you have connected the power and communication cables correctly. (If the power cable and communication cables one mixed up or connected incorrectly, the PCB will be damaged.)
- 2) Check the thermistor sensor, drain pump/hose, and display are connected correctly.

3. Press K1 or K2 on the outdoor unit PCB to run the test mode and stop.

- ◆ Press K1 button → Start Heating test mode → Press K1 button → Stop → Heating test mode 7-seg display :
- ◆ Press K2 button → Start Cooling test mode → Press K2 button → Stop → Cooling test mode 7-seg display :
- ◆ Press K1 button twice → Start Defrost test mode → Press K1 button → Stop → Defrost test mode 7-seg display :
- ◆ Press K2 button twice → Start Inverter Checker mode → Press K2 button → Stop → Inverter Checker mode 7-seg display : (For a service only)

Condition 1 : The outdoor temperature is under 10°C

Condition 2 : All the temperature conditions should meet the defrost conditions

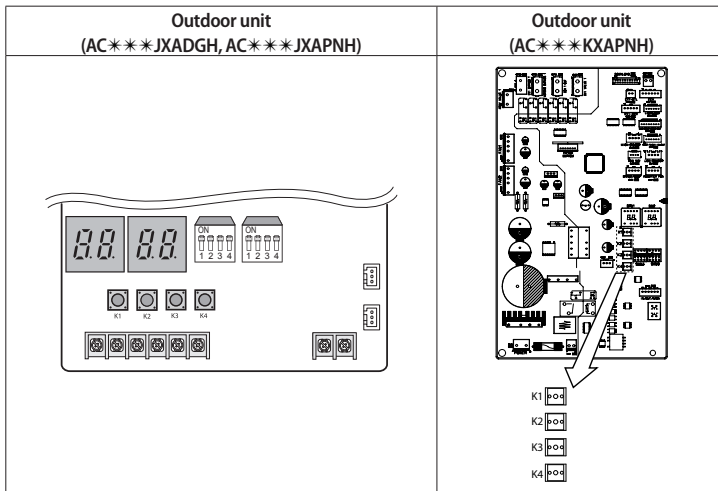

Testing operations

4. After 12 minutes of stationary condition check each indoor unit air treatment :

- ◆ Cooling mode(indoor unit check) → Inlet air temp. - Outlet air temp. : From 10°C to 12°C
- ◆ Heating mode(indoor unit check) → Outlet air temp. - Inlet air temp. : From 11°C to 14°C
- ◆ In heating mode, the indoor fan motor can remain off to avoid cold air blown into conditioned space.

5. How to reset the power supply of the outdoor unit and deactivate the eco mode (standby mode) :

- ◆ Outdoor unit type A :
Press [K3] button over 1 sec to reset the power supply of the outdoor unit and deactivate the eco mode (standby mode)

6. View Mode : When the K4 switch is pressed, you can see information about our system state as below.

Short push	Display contents	SEG1	SEG2		SEG3	SEG4	Unit
1	Order frequency	1	Hundreds' digit		Tens' digit	Unit digit	Hz
2	Current frequency	2	Hundreds' digit		Tens' digit	Unit digit	Hz
3	The number of current indoor units	3	Hundreds' digit		Tens' digit	Unit digit	EA
4	The sensor for outdoor air intake	4	+ / -		Tens' digit	Unit digit	°C
5	Discharge sensor	5	Hundreds' digit		Tens' digit	Unit digit	°C
6	Eva-Mid sensor	6	+ / -		Tens' digit	Unit digit	°C
7	Cond sensor	7	+ / -		Tens' digit	Unit digit	°C
8	Current	8	Tens' digit		Unit digit	The first place of decimals	A
9	Fan RPM	9	Thousands' digit		Hundreds' digit	Tens' digit	rpm
10	Target discharge temperature	A	Hundreds' digit		Tens' digit	Unit digit	°C
11	EEV	B	16kW	Hundreds' digit	Tens' digit	Unit digit	step
			18/20/25kW	Thousands' digit	Hundreds' digit	Tens' digit	
12	The capacity sum of indoor units	C	Tens' digit		Unit digit	The first place of decimals	kW
13	Protective control	D	0: Cooling 1: Heating		Protective control 0: No Protective control 1: Freezing 2: Non-stop defrosting 3: Over-load 4: Discharge 5: Total electric current	Frequency status 0: Normal 1: Hold 2: Down 3: Up_limit 4: Down_limit	-
14	The temperature of heat radiating plate	E	Hundreds' digit		Tens' digit	Unit digit	-
15	S/W check	F	-		-	-	-

Long push 1	Main micom version	Year (Hex)	Month (Hex)	Date (Tens' digit)	Date (Unit digit)	
After short push 1	Inverter micom version	AC***JXAPNH	Year (Hex)	Month (Hex)	Date (Tens' digit)	Date (Unit digit)
		AC***KXAPNH	Year (Dec)			
After short push 1 (Only AC***KXAPNH)	Fan1 version	AC***KXAPNH	Year (Dec)	Month (Hex)	Date (Tens' digit)	Date (Unit digit)
After short push 1 (Only AC***KXAPNH)	Fan2 version	AC***KXAPNH	Year (Dec)	Month (Hex)	Date (Tens' digit)	Date (Unit digit)
After short push 1	E2P version	AC***JXAPNH	Year (Hex)	Month (Hex)	Date (Tens' digit)	Date (Unit digit)
		AC***KXAPNH	Year (Dec)			

※ Long push K4(Main micom ver.) → short push 1 more(Inv. micom ver.) → short push 1 more(E2P. ver.)

Testing operations

7. DIP switch option

(AC***JXADGH, AC***JXAPNH)

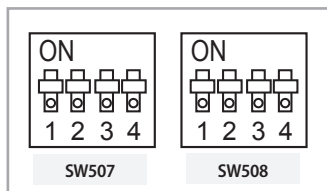

(AC***KXAPNH)

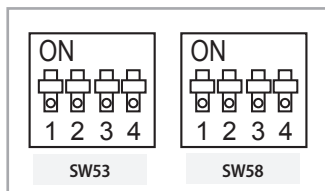

► DIP switch(SW507/SW53) option

	On (default)	Off
Switch 2	Disable snow prevention control	Enable snow prevention control
Switch 3	Silence Mode option	
Switch 4		

※ When snow prevention mode is in use, eco mode(standby mode)will not be functional.

► DIP switch(SW508/SW58) option

	On(default)	Off
Switch 1	Auto Silence Mode	Manual Silence Mode
Switch 2	-	-
Switch 3	-	-
Switch 4	-	-

8. Silence Mode DIP switch option

► DIP switch(SW507/SW53) option

Switch 3	Switch 4	Operation
On	On	Disable Silence mode
On	Off	Silence mode 1st step
Off	On	Silence mode 2nd step
Off	Off	Silence mode 3rd step

Troubleshooting

The table below give indication about self diagnostic routine. Some of error code requires activities exclusively for Authorized Service Center.

Outdoor unit

If an error occurs during the operation, it is displayed on the outdoor unit PCB LED, both MAIN PCB and INVERTER PCB.

No.	Error Code	Meaning	Remarks
1	E108	Error due to repeated address setting(when 2 or more devices has same address within the network)	Check on repeated indoor unit main address
2	E121	Error on indoor temperature sensor of indoor unit(Short or Open)	Indoor unit Room Thermistor Open/Short
3	E122	Error on EVA IN sensor of indoor unit(Short or Open)	Indoor unit EVA_IN Thermistor Open/Short
4	E123	Error on EVA OUT sensor of indoor unit(Short or Open)	Indoor unit EVA_OUT Thermistor Open/Short
5	E153	Error on float switch (2nd detection)	"Indoor unit Float Switch Open/Short Drain Pump operation Check"
6	E154	RPM feedback error of indoor unit	Check on indoor unit indoor Fan operation
7	E162	Outdoor unit EEPROM Read/Write error (H/W)	Check Outdoor EEPROM PBA
8	E163	Outdoor unit EEPROM Read/Write error (Option)	Check Outdoor EEPROM Data
9	E198	Error on thermal fuse of indoor unit (Open)	Thermal Fuse Open Check of indoor unit Terminal Block
10	E201	"Communication error between indoor and outdoor unit(Installation number setting error repeated indoor unit address,indoor unit communication cable error)"	Check indoor quantity setting in outdoor
11	E202	"Communication error between indoor and outdoor unit(Communication error on all indoor unit, outdoor unit communication cable error)"	Check electrical connection and setting between indoor unit and outdoor unit
12	E205	Communication error on all PBA within the outdoor unit C-Box,communication cable error	-
13	E206	E206-C002 : Fan PBA communication error, E206-C003 : INV PBA communication error	-
14	E221	Error on outdoor temperature sensor (Short or Open)	Check Outdoor sensor Open / Short
15	E231	Error on outdoor COND OUT sensor (Short or Open)	Check Cond-Out sensor Open / Short
16	E251	Error on discharge temperature sensor of compressor 1 (Short or Open)	Check Discharge sensor Open / Short
17	E320	Error on OLP sensor (Short or Open)	Check OLP sensor Open / Short
18	E346	Error due to operation failure of Fan2	FAN2 error
19	E347	Motor wire of Fan2 is not connected	FAN2 error
20	E348	Lock error on Fan2 of outdoor unit	FAN2 error
21	E353	Error due to overheated motor of outdoor unit's Fan2	FAN2 error
22	E355	Error due to overheated IPM of Fan2	FAN2 error
23	E378	Error due to overcurrent of Fan2	FAN2 error
24	E386	Over-voltage/low-voltage error of Fan2	FAN2 error
25	E387	Hall IC connection error of Fan2	FAN2 error
26	E389	V-limit error on Fan2 of compressor	FAN2 error
27	E391	Error due to DataFlash of Fan2	FAN2 error
28	E393	Output current sensor error of Fan2	FAN2 error





Troubleshooting

No.	Error Code	Meaning	Remarks
29	E396	DC voltage sensor error of Fan2	FAN2 error
30	E399	Heat sink temperature sensor error of Fan2	FAN2 error
31	E403	Compressor down due to freeze protection control	Check Outdoor Cond.
32	E404	System stop due to overload protection control	Check Comp. when it start
33	E416	System stop due to discharge temperature	-
34	E422	Blockage detected on high pressure pipe	1. Check if the service valve is open
			2. Check for refrigerant leakage(pipe connections, heat exchanger) and charge refrigerant if necessary
			3. Check if there's any blockage on refrigerant cycle(indoor unit/outdoor unit)
			4. Check if additional refrigerant has been added after pipe extension
35	E425	Reverse phase or open phase	Check whether 3 phase is reversed or opened.
36	E440	Heating mode restriction due to high air temperature	HEATING
37	E441	Cooling mode restriction due to low air temperature	COOLING
38	E446	Error due to operation failure of Fan1	FAN1 error
39	E447	Motor wire of Fan1 is not connected	FAN1 error
40	E448	Lock error on Fan1 of outdoor unit	FAN1 error
41	E452	Error due to ZCP detection circuit problem or power failure	-
42	E453	Error due to overheated motor of outdoor unit's Fan1	FAN1 error
43	E455	Error due to overheated IPM of Fan1	FAN1 error
44	E458	Fan speed error	FAN1 ERROR
45	E461	Error due to operation failure of inverter compressor	-
46	E462	System stop due to full current control	-
47	E463	Over current trip / PFC over current error	Check OLP sensor
48	E464	IPM Over Current(O.C)	IPM
49	E465	Comp. Over load error	-
50	E466	DC-Link voltage under/over error	Check AC Power and DC Link Voltage
51	E467	Error due to abnormal rotation of the compressor or unconnected wire of compressor	Check Comp wire
52	E468	Error on current sensor (Short or Open)	Check Outdoor Inverter PBA.
53	E469	Error on DC-Link voltage sensor (Short or Open)	-
54	E471	Outdoor EEPROM checksum error between MAIN and INVERTER (AC***KXAPNH)	Check Outdoor EEPROM PBA
55	E472	AC Line Zero Cross Signal out	-
56	E473	Comp Lock error	-
57	E474	Error on IPM Heat Sink sensor of inverter 1 (Short or Open)	heck Outdoor Inverter PBA
58	E475	Error on inverter fan 2	FAN2 ERROR
59	E478	Error due to overcurrent of Fan1	FAN1 error
60	E484	PFC Overload (Over current) Error	Check Outdoor Inverter PBA.
61	E485	Error on input current sensor of inverter 1 (Short or Open)	Check Outdoor EEPROM PBA
62	E486	Over-voltage/low-voltage error of Fan1	FAN1 error

No.	Error Code	Meaning	Remarks
63	E487	Hall IC connection error of Fan1	FAN1 error
64	E489	V-limit error on Fan1 of compressor	FAN1 error
65	E491	Error due to DataFlash of Fan1	FAN1 error
66	E493	Output current sensor error of Fan1	FAN1 error
67	E496	DC voltage sensor error of Fan1	FAN1 error
68	E499	Heat sink temperature sensor error of Fan1	FAN1 error
69	E500	IPM over heat error on inverter 1	Check Outdoor Inverter PBA.
70	E508	Smart install is not installed	-
71	E554	Gas leak detected	Check the refrigerant
72	E556	Error due to mismatching capacity of indoor and outdoor unit	Check the indoor and Outdoor unit Capacity
73	E557	Option code miss matching among the indoor units (only for DPM)	Check the indoor option code
74	E590	Outdoor EEPROM checksum error between MAIN and INVERTER	-
75	E660	Inverter Boot Code error	-

Extending the power cable

1. Prepare the following tools.

Tools	Crimping pliers	Connection sleeve (mm)	Insulation tape	Contraction tube (mm)
Spec	MH-14	20xØ6.5(HxOD)	Width 19mm	70xØ8.0(LxOD)
Shape				

2. As shown in the figure, peel off the shields from the rubber and wire of the power cable.

- Peel off 20 mm of cable shields from the pre-installed tube.

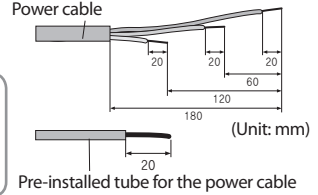

- For information about the power cable specifications for indoor and outdoor units, refer to the installation manual.
- After peeling off cable wires from the pre-installed tube, insert a contraction tube.

3. Insert both sides of core wire of the power cable into the connection sleeve.

► **Method 1**

Push the core wire into the sleeve from both sides.

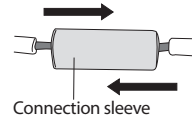

► **Method 2**

Twist the wire cores together and push it into the sleeve.

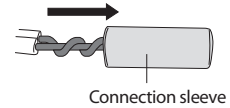

4. Using a crimping tool, compress the two points and flip it over and compress another two points in the same location.

- The compression dimension should be 8.0.

- After compressing it, pull both sides of the wire to make sure it is firmly pressed.

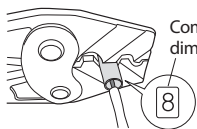

► **Method 1**

Compress it 4 times.

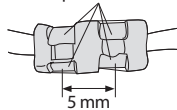

► **Method 2**

Compress it 4 times.

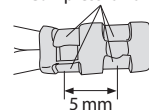

5. Wrap it with the insulation tape twice or more and position your contraction tube in the middle of the insulation tape.

Three or more layers of insulation are required.

► **Method 1**

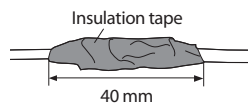

► **Method 2**

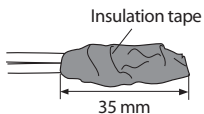

6. Apply heat to the contraction tube to contract it.

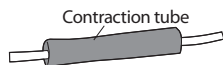

7. After tube contraction work is completed, wrap it with the insulation tape to finish.



- Make sure that the connection parts are not exposed to outside.
- Be sure to use insulation tape and a contraction tube made of approved reinforced insulating materials that have the same level of withstand voltage with the power cable. (Comply with the local regulations on extensions.)

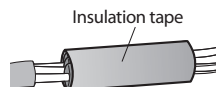

- In case of extending the electric wire, please DO NOT use a round-shaped Pressing socket.
- Incomplete wire connections can cause electric shock or a fire.

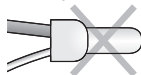

SAMSUNG



AC***JXADGH
AC***JXAPNH
AC***KXAPNH

Air Conditioner installation manual

imagine the possibilities

Thank you for purchasing this Samsung product.



EN ES DB68-06789A-00

SAMSUNG