

INDOOR UNIT

OUTDOOR UNIT

Model:	AC026RN1DKG	AC035RNMDKG	AC026RXADKG
	AC035RN1DKG	AC052RNMDKG	AC035RXADKG
	AC026RNNDKG	AC071RNMDKG	AC052RXADKG
	AC035RNNDKG	AC100RNMDKG	AC071RXADKG
	AC052RNNDKG	AC120RNMDKG	AC100RXADKG
	AC071RNNDKG	AC140RNMDKG	AC100RXADNG
	AC052RN4DKG	AC026RNADKG	AC120RXADKG
	AC071RN4DKG	AC035RNADKG	AC120RXADNG
	AC100RN4DKG	AC052RNADKG	AC140RXADKG
	AC120RN4DKG	AC071RNADKG	AC140RXADNG
	AC140RN4DKG	AC052RNCDKG	
	AC071RN4PKG	AC071RNCDKG	
	AC100RN4PKG	AC100RNCDKG	
	AC120RN4PKG	AC120RNCDKG	
	AC140RN4PKG	AC140RNCDKG	
	AC026RNLDKG	AC100RNTDKG	
	AC035RNLDKG	AC026RNJDKG	
	AC052RNLDKG	AC035RNJDKG	
	AC071RNLDKG	AC052RNJDKG	

SERVICE Manual

AIR CONDITIONER

CONTENTS



1. Precautions
2. Product Specifications
3. Disassembly and Reassembly
4. Troubleshooting
5. PCB Diagram
6. Wiring Diagram
7. Reference Sheet

Contents

1. Precautions.....	1-1
1-1 Precautions for the Service	1-1
1-2 Precautions related to static electricity and PL	1-1
1-3 Precautions related to product safety.....	1-2
1-4 Other precautions.....	1-2
2. Product Specifications	2-1
2-1 CAC Single.....	2-1
2-2 The Feature of Product.....	2-2
2-2-1 Features (Wind-Free 1Way CST).....	2-2
2-3 The Feature of Product.....	2-3
2-3-1 Features (Wind-Free 4Way CST).....	2-3
2-4 Features & Benefits	2-8
2-4-1 4Way Cassette (600 x 600).....	2-8
2-4-2 4Way Cassette (600 x 600) - Tasteful design, Compact, Lightweight build	2-8
2-4-3 360 Cassette	2-10
2-4-4 Slim Duct - Ultra-light, adaptable design	2-12
2-4-5 Duct S	2-14
2-4-6 Ceiling Type - Slim yet functional design	2-15
2-4-7 Ceiling Type (large capacity) - Powerful cooling with a long distance wind.....	2-16
2-4-8 Wall Mount Type	2-18
2-4-9 AR9000, 7000, 5000 Series - Triangular design, powerful cooling	2-19
2-5 Product Specifications	2-20
2-6 Specifications of optional items	2-42
2-6-1 Accessories	2-42
3. Disassembly and Reassembly	3-1
3-1 Indoor unit	3-2
3-2 Outdoor unit	3-86
4. Troubleshooting	4-1
4-1 Setting an indoor unit address and installation option	4-1
4-1-1 The procedure of setting option.....	4-1
4-1-2 The procedure of setting option	4-2
4-1-3 Order for Setting Options (Wired Remote Controller)	4-5
4-1-4. Setting the indoor unit addresses	4-6
4-1-5. Setting an indoor unit installation option (Suitable for the condition of each installation location).....	4-7
4-1-6 Changing a particular option	4-21
4-1-7. Emergency Temperature Output (ETO) function.....	4-22
4-1-8 Option code for each model	4-24
4-2 Items to check before diagnostics.....	4-26
4-2-1 Test run mode and View mode	4-26
4-2-2 Eco Mode [Power Saving Mode].....	4-33
4-2-3. Error code [Indoor Unit].....	4-34
4-2-4 Outdoor Unit	4-45
4-2-5 Wired remote controller.....	4-48

Contents

4-3 Troubleshooting by symptoms	4-51
4-3-1 Indoor temperature sensor (open/short)	4-51
4-3-2 Indoor heat exchanger temperature sensor (open/short).....	4-52
4-3-3 Indoor FAN error	4-53
4-3-4 Communication error after finishing Tracking.....	4-54
4-3-5 Indoor unit float sensor error.....	4-55
4-3-6 EEPROM circuit failure.....	4-56
4-3-7 E407	4-57
4-3-8 When the outdoor unit power is not ON - Initial Diagnosis: 3-phase products	4-58
4-3-9 Indoor/outdoor communication error (1min.) (Error Code: E202).....	4-62
4-3-10 Communication error between outdoor unit INV ↔ MAIN MICOM (1 min.) (Error Code: E203).....	4-64
4-3-11 Outdoor sensor error (Error Code: E221, E231, E251, E320)	4-65
4-3-12 Reverse phase/Loss phase detection (3-phase outdoor unit) (Error Code: E425)	4-66
4-3-13 Compressor down due to freezing control (Error Code: E403).....	4-67
4-3-14 Outdoor unit Fan error (Error Code: E458, E475)	4-68
4-3-15 Compressor starting error/rotation error (Error Code: E461, E467).....	4-69
4-3-16 Full current error/PFC over-current error (Error Code: E462, E484).....	4-71
4-3-17 IPM over current error (Error Code: E464).....	4-72
4-3-18 DC LINK over-current/low-voltage error (Error Code: E466) H/W DC_Link Over Voltage Error (Error Code: E483) AC Input Voltage Sensor Error (Error Code: E488).....	4-75
4-3-19 Gas leakage error (Error Code: E554).....	4-76
4-3-20 Outdoor unit High Pressure Switch Error (E507).....	4-77
4-3-21 Pipe blockage error (Error Code: E422).....	4-79
4-3-22 Smart install mode was not carried out (Error Code: E508).....	4-80
4-3-23 Others	4-82
5. PCB Diagram and Parts List	5-1
5-1 Indoor Unit	5-1
5-1-1 MAIN PCB	5-1
5-1-2 Display PCB.....	5-21
5-1-3 Sub PCB	5-27
5-1-4 BLDC PBA.....	5-29
5-1-5 Receiver PCB	5-31
5-1-6 Switch PCB.....	5-32
5-2 Outdoor Unit	5-33
5-2-1 MAIN PCB	5-33
5-2-2 INVERTER PCB	5-41
5-2-3 EMI PBA.....	5-49
6. Wiring Diagram	6-1
6-1 Indoor Unit.....	6-1
6-2 Outdoor unit.....	6-17
7. Reference Sheet	7-1
7-1 Index for Model Name	7-1
7-1-1 Indoor Unit.....	7-1
7-1-2 Outdoor Unit	7-2
7-1-3 Panel	7-3
7-2 Refrigerating Cycle Diagram.....	7-4

1. Precautions

1-1 Precautions for the Service

- **Use the standard parts when replacing the electric parts.**
 - Confirm the model name, rated voltage, rated current of the electric parts.
- **When repairing the equipment, connection of the harness parts must be firm and solid.**
 - A loose connection may cause noise or other malfunction.
- **When assembling and disassembling the equipment while it is laid down, lay it on soft cloth.**
 - Otherwise it may scratch the back of the exterior of the product.
- **Remove dust or dirt completely from the housing block, wiring block and service parts during repair.**
 - This helps prevent the danger of fire caused by tracking or short circuit.
- **Fasten the valve caps of service valves and charging valves of outdoor unit as much as possible using adjustable wrenches.**
- **Check the status of the components' assembly after repair service.**
 - The status must be the same as before the repair service.

1-2 Precautions related to static electricity and PL

- **The PCB power supply block is susceptible to static electricity.**
Therefore, care must be taken during repair or measuring while the power is on.
 - Wear insulation gloves for PCB repair or measuring.
- **Check whether the installation location is at least two meters away from other electronic products such as TV, video, or audio.**
 - Otherwise, the video quality might be degraded or noise might be generated.
- **Do not let end users repair the products themselves.**
 - Unauthorized disassembly might cause electric shock or fire.

1-3 Precautions related to product safety

- **Do not pull the power cord and do not touch the power plug or aux power switch with wet hands.**
 - It might cause electric shock or fire.
- **A damaged power line or power plug must be replaced to prevent danger.**
- **Do not bend the power cable with excessive force, and do not place a heavy weight on the case as it might damage the cable.**
 - It might cause electric shock or fire.
- **Do not use multiple electric outlets.**
 - This might cause electric shock or fire.
- **Connect the ground terminal when necessary.**
 - You must connect the ground terminal if you determine that there is a danger of electric leakage due to moisture or water.
- **Unplug the power cable or turn off the auxiliary power switch for electric part replacement and repair service.**
 - Otherwise it might cause electric shock.
- **Instruct end users to separate the batteries from the remote controllers and store them separately when the product is not used for long time.**
 - Otherwise leakage from the dry cell may cause problems with the remote controller.

1-4 Other precautions

- **The pipes should have no leaks during installation, and the compressor must be stopped before removing connecting pipes for pump down work. Operating the compressor while the service valve is open and refrigerant pipe is not properly connected may cause explosion or injury due to abnormal high pressure created inside the refrigerant cycle as the air can be absorbed through the pipe.**
- **Pump Down work procedure (When uninstalling the product)**
 - Turn on the air conditioner, select cooling operation, and run the compressor for more than three minutes.
 - Release the high pressure and low pressure valve caps.
 - Close the high pressure valve completely using an L-wrench.
 - After about two minutes, close the low pressure valve completely.
 - Stop running the air conditioner.
 - Separate the connecting pipe.

2. Product Specifications

2-1 CAC Single

■ Stabilize the atmosphere with broad temperature allowance and control

Samsung is dedicated to supporting comfortable living and working environments based on the strength of its technologies. With a single unit, CAC Single delivers reliable comfort and control over multiple areas to ensure a pleasant atmosphere in any climate.

■ Wide temperature performance

No matter how extreme the temperature, the highperforming CAC Single can handle the condition without the need for an additional unit. Featuring a wide temperature allowance, it can cool in heat of up to 50 and provide warmth in the freezing cold of -20°C to ensure a constant and comfortable home environment.

■ Ideal comfort in minutes

The CAC Single digital inverter air conditioner works at maximum capacity at startup. As soon as the temperature reaches the desired or set temperature, CAC Single performs fine adjustments to cope with any changes. This means less temperature fluctuation and ideal comfort in a matter of minutes.

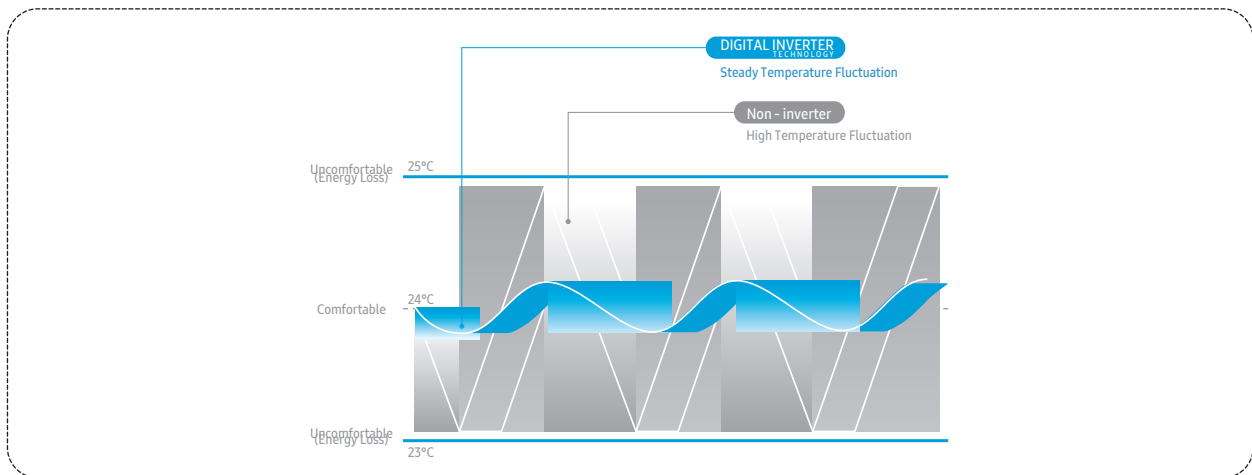

■ Versatile piping installation

CAC Single outdoor units offer a selection of pipe directions. The internal pipe connection ports allow four different pipe directions, supporting a neater, more organized-looking unit upon installation.



2-2 The Feature of Product

2-2-1 Features (Wind-Free 1Way CST)

■ Wind-Free cooling

Comfort wind implementation by Wind-Free cooling.

※ Wind-Free implementation: Still air by the velocity of flow below 0.15m/s.

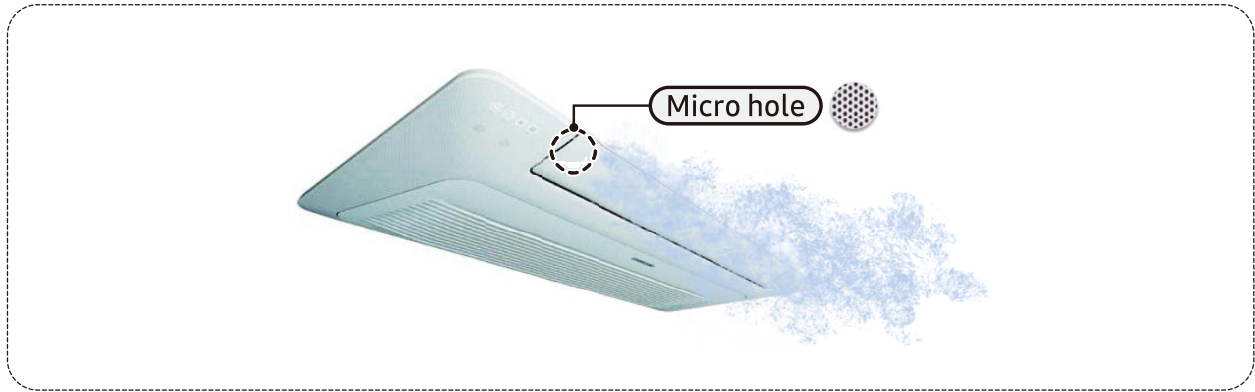

■ Big blade

Max. 8m Horizontal reach

※ Blade enlargement about 47% compare to conventional product

※ Reach: 8m (Height 0.6m, Wind speed 0.3m/s) Conventional product (Samsung): 5m

※ Based on Wind-Free 1Way 7.1kW

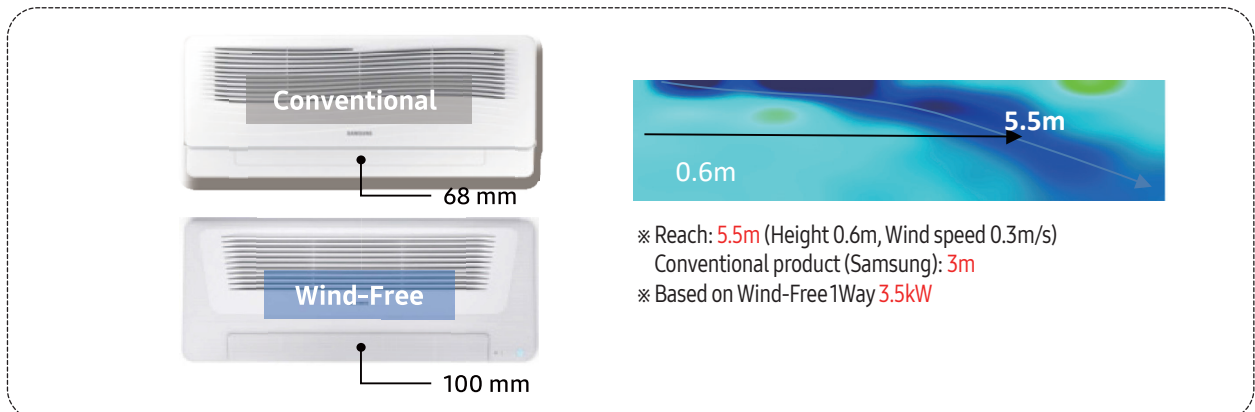

■ Even cooling

Even cooling For spacious space

※ Expand the blade angle from 30° to 80°

Conventional product (Samsung): 40~80°

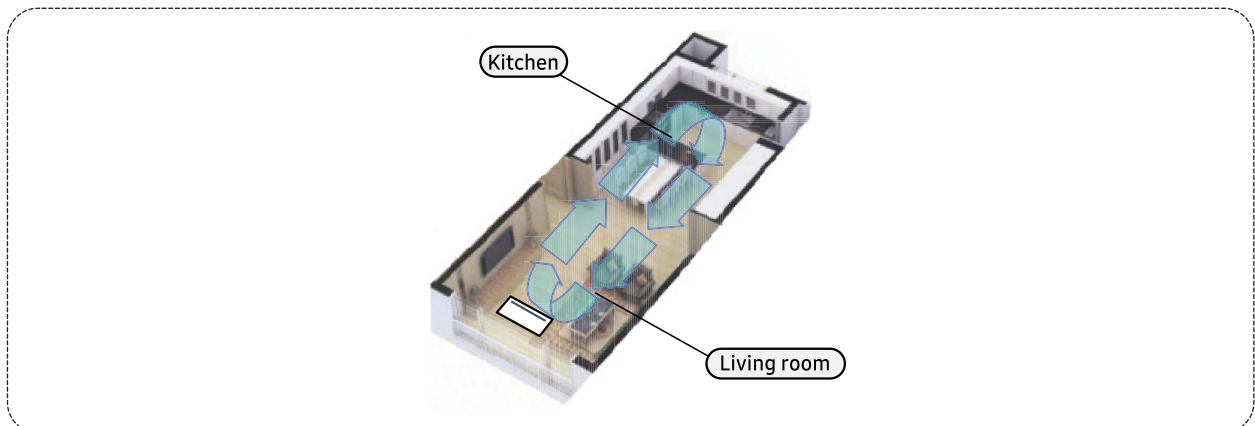

2-3 The Feature of Product

2-3-1 Features (Wind-Free 4Way CST)

■ Wind-Free Cooling with Micro holes

The Wind Free Air conditioner pushes air out through 15,000 micro holes in the panel, producing a dispersed and gentle flow of air actually defined as “still air” and the key here is all of those holes create a still, cooled air flow that infiltrates the room gently and softly.

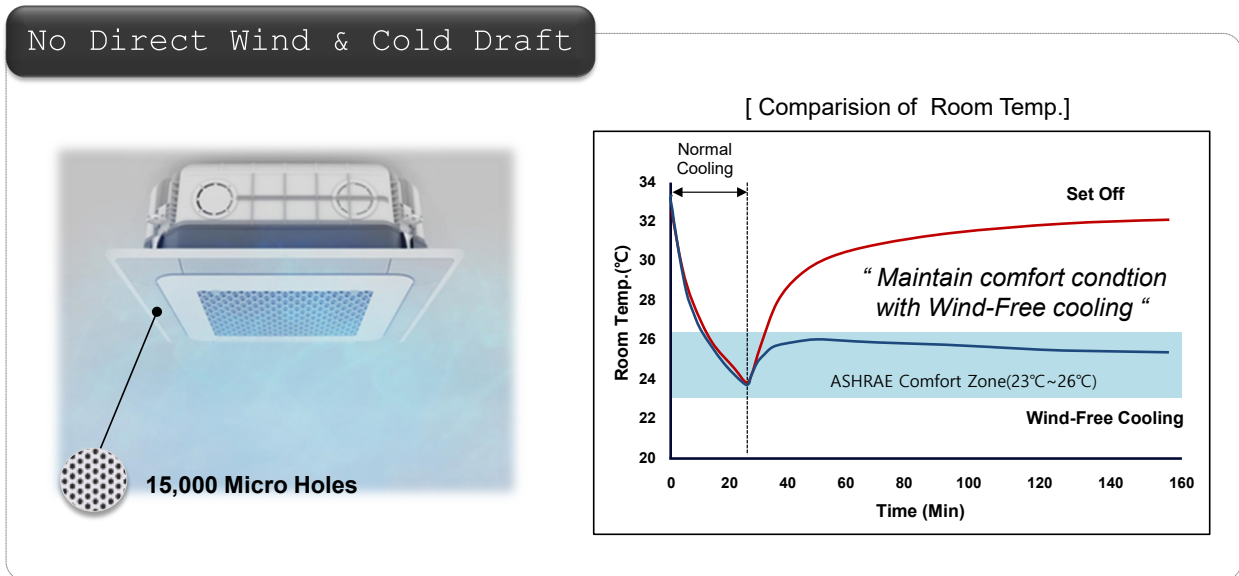

■ Wind-Free Cooling with Micro holes

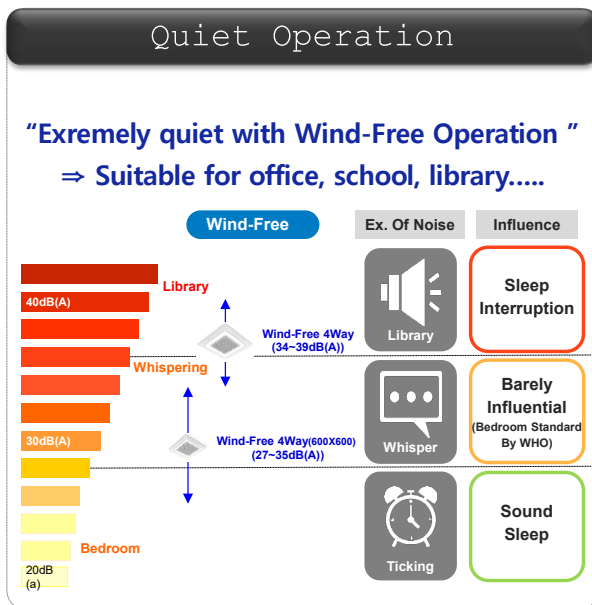

Features (Wind-Free 4Way CST) (cont.)

- **Big Blade, Long Wind**
Big and optimized blades enable wider cooling range.

Wider Cooling Range

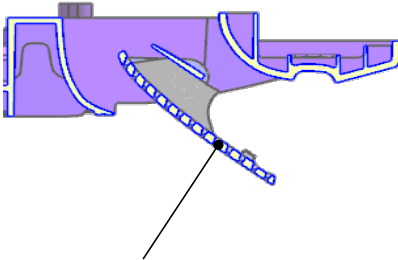

81mm Big Blade (26% ↑)
Optimized Blade Shape

Wind-Free 4Way



5.0m
Wider Cooling area

Conventional 4Way



2.5m

- **Smart Comfort Operation**
Smart comfort operation enable to maintain optimal room condition automatically by detecting not only temperature but also relative humidity.

Automatic Wind-Free Operation

If room reaches comfort zone

If room get out of comfort zone



Normal Cooling **Wind-Free Cooling** **Normal Cooling**

Features (Wind-Free 4Way CST) (cont.)

■ New MDS operation (Option)

New designed Motion Detect enable customized air direction and efficient operation by detecting the location of people.

Automatic MDS Operation (Option)

Motion Detect

※ MDS : Motion Detect Sensor

1. Wind Direction

"Direct wind or Indirect wind"

Choose your comfort

Direct wind

Indirect wind

2. Energy Saving

35%→50% Energy saving

"Wind-Free + OFF Control"

Power Input

Absence

Wind free Saving

Wind free cooling

Conventional Saving 35%

Stop

120mins
30mins
50mins

■ World's Lightest Weight

Advanced Features

Company A

26kg

SAMSUNG

17kg

35% Lighter

Features (Wind-Free 4Way CST) (cont.)

- **Easy Installation in 4 Different Ways**
Freely install anywhere without worrying about direction. (Body and Panel as well)

Advanced Features

No Limitation of direction (Both Body & Panel)

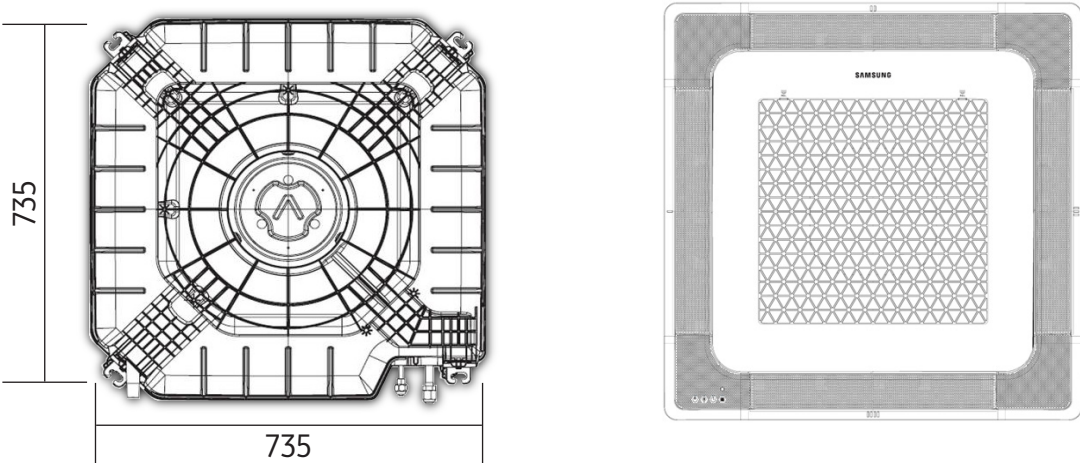

- **New Improved Design**

Advanced Features

New Stylish and Aesthetic Panel



Simple Display

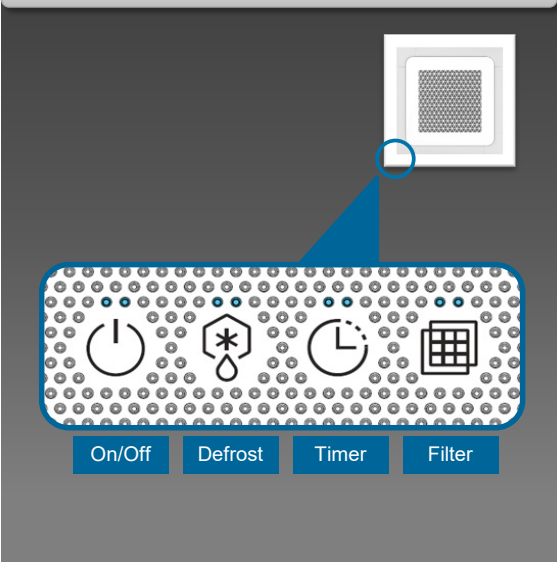

Features (Wind-Free 4Way CST) (cont.)

- ENo Back Flowing Drain Water**
 Check Valve on the drain pump prevents drain water from reversing
 → Minimize water gathering in Drain Board to prevent rusting

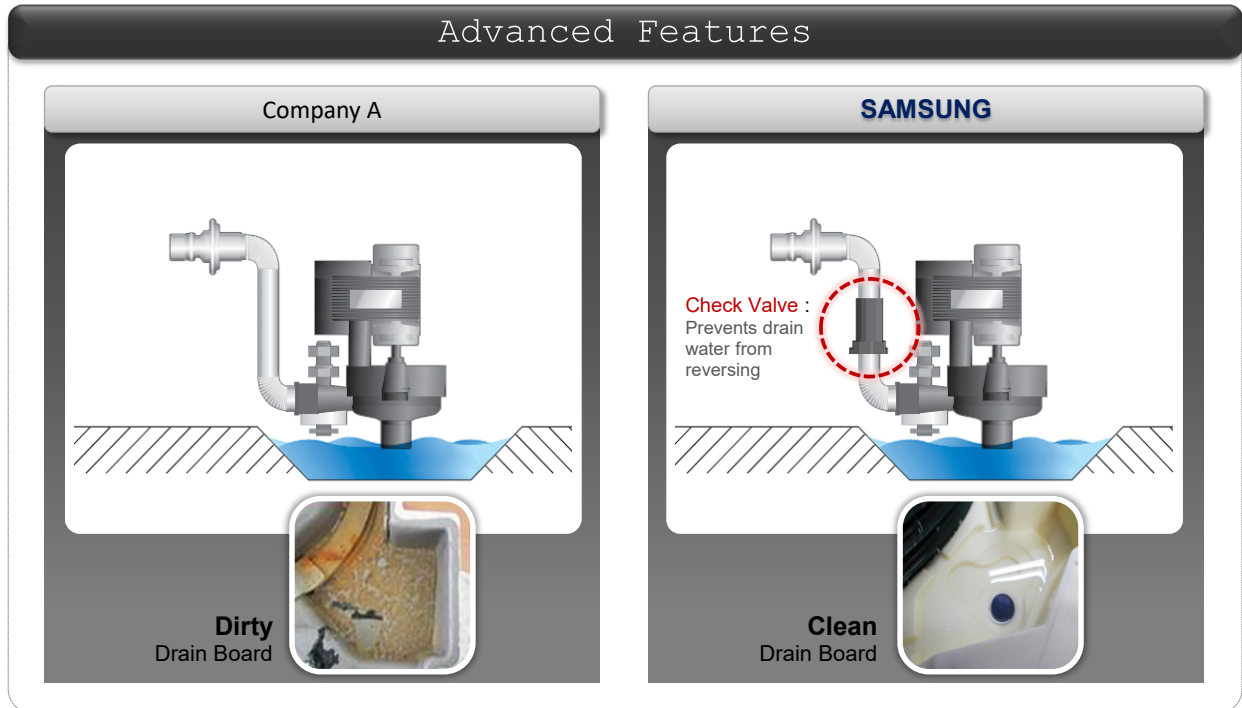

- Easy Maintenance**
 Easy Air Flow Blade Cleaning

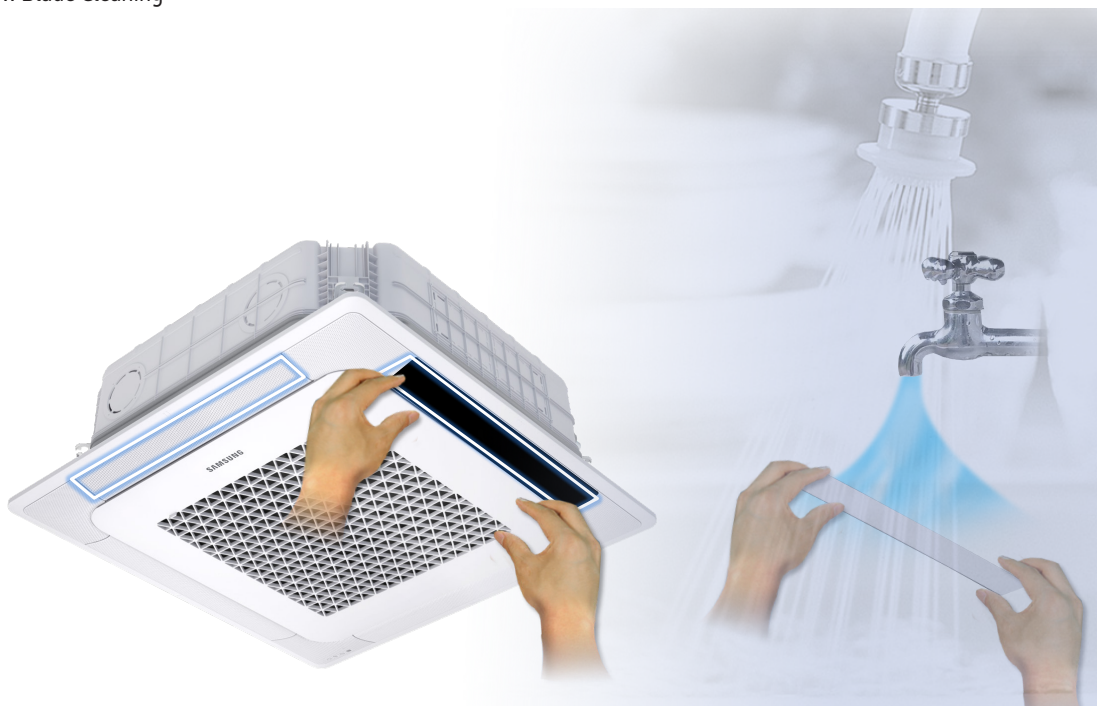

2-4 Features & Benefits

2-4-1 4Way Cassette (600 x 600)

■ **Add chic flair to your interior design with a stylish yet powerful AC system**

Samsung's advanced 4Way Cassette (600 x 600) builds on the aesthetic appeal and performance of the standard 4Way Cassette with an enhanced design. The 4Way Cassette (600 x 600) comes in a variety of patterns to complement any interior. The stylish cassette unit visually harmonizes with the indoor space, while efficient cooling and heating performance make it a dependable and practical air conditioning solution. The 4Way Cassette (600 x 600) indoor air conditioning system provides high-performance heating and cooling in an elegant design with features such as:

- **Tasteful design and compact, lightweight build.**
Create a polished ambiance with a discreetly sized design and a choice of attractive panel patterns.
- **Enhanced comfort control.**
Optimize comfort and save energy with optional motion detection.
- **Low maintenance and powerful airflow.**
Ease installation and maintenance and maximize airflow with an efficient design and robust performance.

2-4-2 4Way Cassette (600 x 600) - Tasteful design, Compact, Lightweight build

■ **Refine the interior with an elegant, compact design**

The enhanced Samsung 4Way Cassette (600 x 600) indoor air conditioner features a selection of simple panel patterns to blend seamlessly into any interior design. Its uniquely lightweight frame blends effortlessly and beautifully into any décor, while clever blade construction keeps the unit clean for a tidy appearance.

■ **Attractive panel and display**

The 4Way Cassette (600 x 600) features a fashionable panel with a simple, beveled corner design. The rounded panel frame promotes a neat, tidy look for an aesthetic flair that blends perfectly with any ambiance.

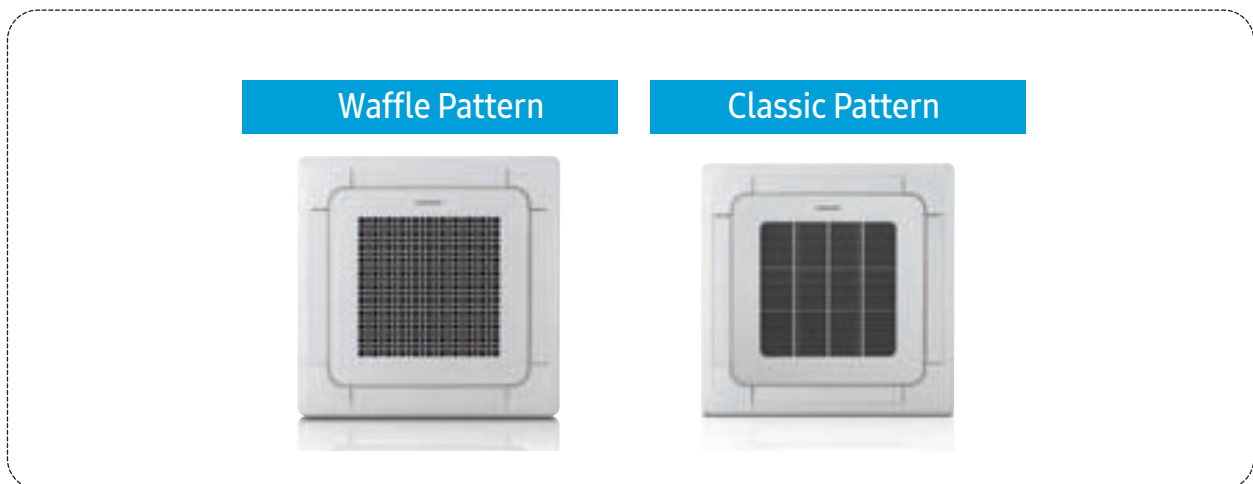

■ **Ultra-compact size**

Samsung's 4Way Cassette (600 x 600) air conditioner can be installed on a single standard ceiling tile (600W x 600D) which helps minimize installation time and effort.



■ **Light, robust design**

The Samsung 4Way Cassette (600 x 600) indoor unit is now lighter in weight at 11kg. It is the lightest indoor unit in the industry, about 35 percent lighter than our conventional products.

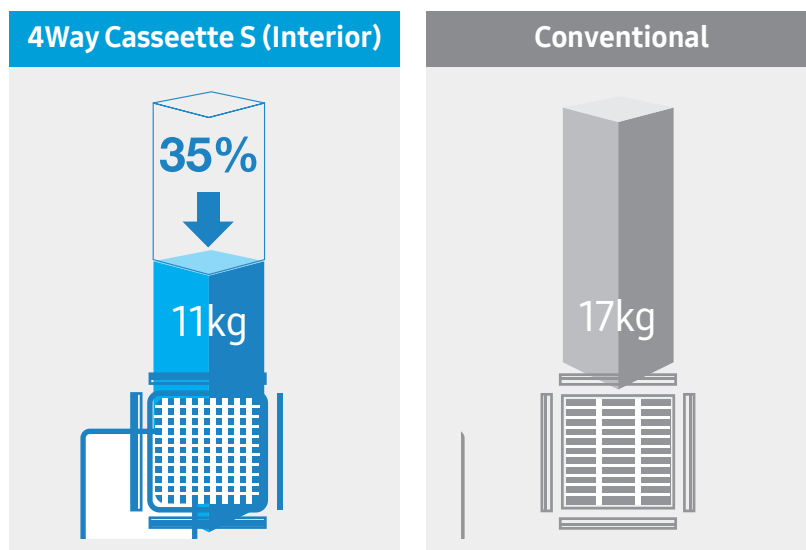

2-4-3 360 Cassette

■ All round cooling and comfort

The Samsung 360 Cassette air conditioner offers a brand new way of staying comfortably cool in every corner of the room. Its innovative circular design not only means it perfectly fits in everywhere, adding a sophisticated look to many different sites, but it also blows cool air in all directions, so that the whole room is the same temperature*. And its bladeless outlet ensures that cool air is gently dispersed, without creating a cold draft**, and doesn't block the air flow, even at low angles, so it expels 25% more air* and spreads it farther.

■ EVENLY CIRCULATES & COOLS EVERY CORNER

Unlike 4-way, cassette type air conditioners that create areas of uneven airflow where cool air can't reach*, a circular outlet blows cool air in all directions, so every corner of a room is the same temperature**.

* Samsung testing compared to a general 4 way cassette type air conditioner.

** Within an 9.3m radius the temperature difference is less than 0.6°C.



* Within an 9.3m radius the temperature difference is less than 0.6°C.

■ Comfortably cool, not cold

A bladeless design softly disperses cool air across the room, making you comfortably cool without feeling a cold draft**. With no blades to block the air flow, it also expels 25% more air* and spreads it farther.



* Within a 5m radius, no cold draft between 0~1.5m in height (with 14.0kw).

■ Circular to perfectly fit in everywhere

Its innovative circular design can match a multitude of interior designs, so it perfectly fits in everywhere. Its minimalist modern styling creates a sophisticated look and its circular shape stands out beautifully.

**■ Spreads more air in more ways**

An innovative Booster Fan enables cool air to be expelled at much lower angles. It creates a low pressure area around the outlet, so that cool air comes out parallel to the ceiling and disperses across a wider area.

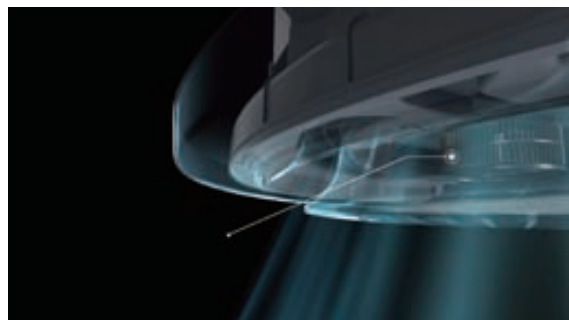
**■ All round simpler & intuitive control**

Intuitively control its performance and see where the air is going. The Wireless Remote Controller's* Jog shuttle and button offer a fun way to adjust the air flow and a Circular LED Display shows its direction.



2-4-4 Slim Duct - Ultra-light, adaptable design



- **Temper any environment with industry-best lightweight design and optimized airflow**
The new Samsung Slim Duct visually blends into the ceiling while providing powerful cool and warm airflow. It's also easy to install and maintain in any interior regardless of the surrounding environment with its compact size and weight—the lightest in the industry.
- **Flexible setup**
The air inlet can be set up either on the bottom or rear of the unit, giving users greater flexibility in installation.

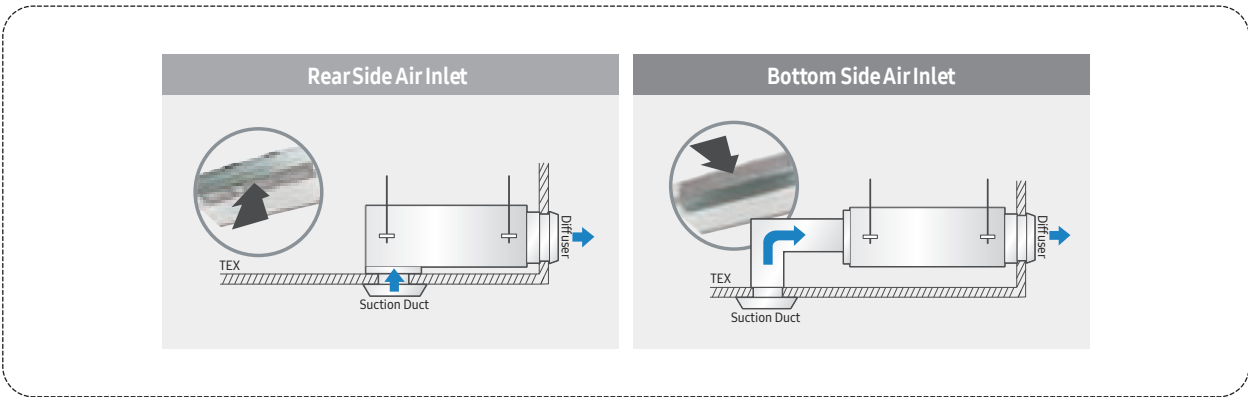

- **Simple drain pump installation**
The new drain pump in the Slim Duct unit can be installed from the side by simply removing the right side panel. Users no longer need to disassemble the top cover to install, check or repair the drain pump for maximum convenience.

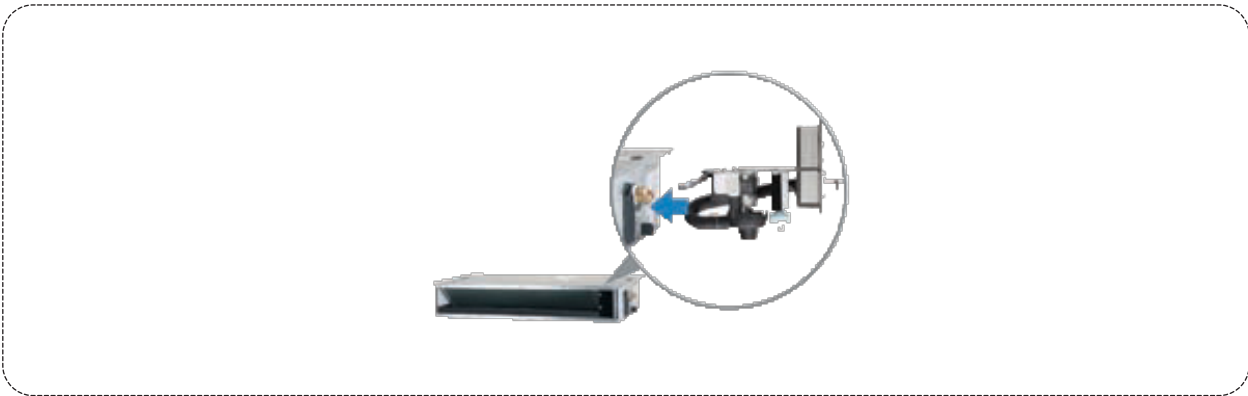

■ Various installation options

Slim Duct S adopts an ultra-compact, slim size with its thin width, which is 200 mm narrower than conventional products. This slender build enables flexible installation and maintenance in various environments..

■ World's lightest weight

The efficient Slim Duct S is the lightest duct air conditioning unit on the market. At a weight that's 15 percent lighter than conventional units, Slim Duct S offers the best in convenient installation and maintenance.

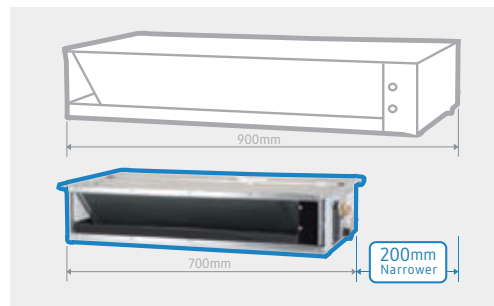
**■ Easy access, easy maintenance**

Slim Duct features a flexible design that enables users to easily access its parts to maintain the unit.

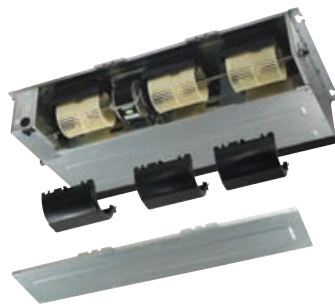

2-4-5 Duct S

■ Overview

Samsung Ducted Type air conditioning units are a smart solution for low-maintenance, consistent cooling and heating performance in any environment. Their compact, slim frame blends seamlessly into ceilings, enhancing the beauty of the interior space and affording users more flexible installation options. Offering a comprehensive lineup, Samsung Ducted Type air conditioning units offer just the right solution for every need--from the office or shop to the restaurant kitchen.

■ Experience performance and convenient comfort for any weather condition

Samsung Duct S delivers unparalleled cooling and heating and flexible management with customizable comfort settings in any climate—all year round. Plus, it boasts a slim, compact size and multiple access points for easy setup exactly where needed.



■ Smart pressure control

Samsung Ducted Type units feature a smart pressure control system. This system adjusts the fan speed based on the external static pressure (ESP), delivering consistent cooling and heating power, regardless of the surrounding environment.

■ Convenient installation

The optional lift-up drain pump lifts condensed water up to 750 mm, compared to a limit of 700 mm on conventional models, for flexible and convenient installation.

The Duct S indoor air conditioning unit delivers smooth, consistent operation and convenience with features such as:

- Efficient operation. Stage the desired atmosphere with energy-efficient performance and customized airflow.
- Smart management. Cool spaces efficiently and manage the air conditioning unit even while away, with features designed for efficiency and control.
- Easy, flexible setup. Install and maintain even multiple units with a compact and easily accessible design.

2-4-6 Ceiling Type - Slim yet functional design

- Distribute refreshing airflow where needed with a compact, flexible design**

Samsung's Ceiling Type indoor unit has 2-way installation options for the ceiling and floor, enabling more efficient use of available space. Users can enjoy crisp, powerful air throughout their entire space from the compact unit in the ceiling or floor.



- Small package, big performance**

The Samsung Ceiling Type air conditioner boasts a slim, compact design—half the size of conventional products—with cooling power comparable to larger units.

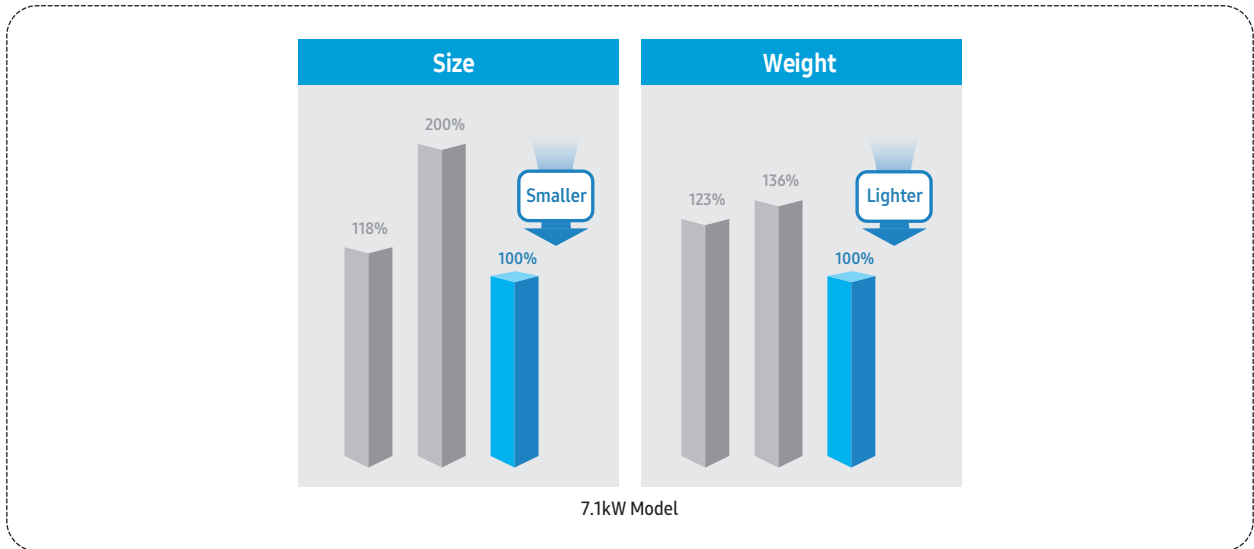

2-4-7 Ceiling Type (large capacity) - Powerful cooling with a long distance wind

- **Combine simple neat and innovated technologies to experience superior performance and easy operation**
Samsung has been rewriting product descriptions beyond the industry standards. As one of such company's product, Samsung Ceiling focused on sending "sufficient" amount of conditioned air to "distant" places to cover huge area. For convenient installations and maintenances, the Ceiling concentrated service direction on one side. Do not get stressed with air conditioning. Just leave it to Samsung Ceiling.



- **Fast cooling, 15m air flow**
When users need air conditioning, they really need it quickly. While the ceiling applied latest flow-efficient blowers to increase amount of air it discharges, it also mounted single BLDC motor to reduce noises and possibilities of abrupt changes of modes. With increased size of inlet area and fluid dynamically designed inner passages, customers can experience incomparable cooling power. Also, with the advanced blade, which can move from 40 to 450, Samsung ceiling type can refreshingly cool air that reaches every corner of the room with no blind spots.

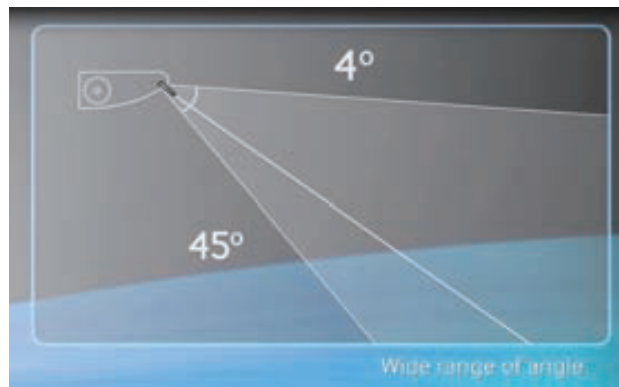

■ Simple display

The simple display design with its rounded corners adds a neat and tidy feeling to your interior.



- Ice Blue: Operating
- Yellow Green: Schedule
- Red: Error
- Orange: Filter Alarm
Time Limit + Operating Pattern

■ Single side installation

Due to difficulties in accessing their installed locations, easiness to maintain ceiling indoor units should be considered seriously. Relatively thin width of the product makes locating all service ports at one side difficult. However, for better customer experience, Samsung challenged to this difficulty.

2-4-8 Wall Mount Type

■ Breathe easily with wall-mounted systems designed for all-day freshness

Samsung Wall Mount Type air conditioners have been designed from the ground up to be exceptionally efficient. With their stylish, innovative designs, these wall-mounted air conditioners optimize comfort with cool, clean, healthy freshness for everyday living.

■ Improved blade operation

Samsung's wide twin blade can open up to 90° for more effective cooling. The longer twin blade ensures that air reaches every corner of the room with greater control.

■ Superior dust filtration

A Full High Density (HD) filter creates cleaner air through enhanced filtration, reducing microscopic dust particles by up to 90 percent.

■ Cleaner, healthier air

Virus Doctor eliminates the harmful substances and viruses breeding in the atmosphere of living spaces, thus providing the highest level of indoor air quality. This smart solution creates a purified zone, eliminating the hazards of air borne allergens and controlling the active oxygen that contributes to disease, cancer and accelerated aging.

■ Good's sleep

Samsung's Wall Mount Type units feature Good's sleep mode for a comfortable bedroom climate perfectly tempered for a restful night. With automatic temperature and moisture adjustment, all three vital stages of sleep are protected from humidity and heat so users wake up fully rested and refreshed.

2-4-9 AR9000, 7000, 5000 Series - Triangular design, powerful cooling

■ Cool every corner of the room with a unique, efficiency-boosting design

Samsung AR9000, 7000, 5000 Series units are designed with efficiency in mind.

Their uniquely triangular design improves performance to circulate cool, clean air throughout every inch of the room. In addition, their smart design includes easy-to-remove filters for easy management and healthier airflow.

■ Faster, farther cooling performance

The units' distinctive triangular design has a wider intake, so more air can be drawn in.

The improved width and angle of the outlet, extra v-blades and bigger fan also ensure that air is cooled and expelled faster and farther. The result is refreshingly cool air that reaches every corner of the room—with no blind spots.

Their Smart Inverter also provides significantly greater energy efficiency.





■ Easy-access maintenance





Unlike conventional filters that are often difficult to access, the Samsung wall-mounted unit filter is on the outside, at the top of the device. Easy access means users can take out the filter, clean it and put it back without having to open a cover or pull hard to get it out. And its antibacterial coating filters dust, dangerous airborne contaminants and allergens for healthier breathing.





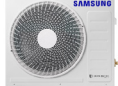

2-5 Product Specifications

Model		Slim 1Way		
		IN	AC026RN1DKG/EU	AC035RN1DKG/EU
		OUT	AC026RXADKG/EU	AC035RXADKG/EU
Image	Indoor Unit			
	Outdoor unit			
	Remote controller			
Performance	cooling [W]		2.60	3.50
	heating [W]		3.30	4.00
Power Consumption	cooling [kW]		0.72	1.09
	heating [kW]		1.01	1.28
Voltage/Frequency [Ø, #, V, Hz]			1, 2, 220-240, 50	1, 2, 220-240, 50
Operating Current	cooling [A]		3.8	5.3
	heating [A]		5.0	6.2
Noise	indoor unit (C/H) [dBA]		40/42	42/44
	outdoor unit (C/H) [dBA]		51/51	53/53
Size	net dimension (W*H*D)	indoor unit [mm]	970 x 135 x 410	970 x 135 x 410
		outdoor unit [mm]	790 x 548 x 285	790 x 548 x 285
	shipping dimension (W*H*D)	indoor unit [mm]	1173 x 231 x 487	1173 x 231 x 487
		outdoor unit [mm]	913 x 622 x 371	913 x 622 x 371
Weight	net weight	indoor unit [kg]	9.2	9.2
		outdoor unit [kg]	32.5	32.5
	shipping weight	indoor unit [kg]	12.0	12.0
		outdoor unit [kg]	35.5	35.5
Harness Specification	indoor fan motor		DB31-00636G	DB31-00636G
	compressor		UB9AK5090FER	UB9AK5090FER
	outdoor fan motor		DB31-00642C	DB31-00642C
Designed Pressure	high pressure [Mpa]		4.1	4.1
	low pressure [Mpa]		1.4	1.4
Refrigerant/Factory charging [g]			R-32	R-32
			900	900
Additional refrigerant			0	0
Basic piping length [m]			5	5
Max.piping length [m]			20	20
max.level difference [m]			15	15
Option Code	Standard		01717C-1930F8-271A21-371120	01717C-19344D-272328-371120
	Installation 1		020000-100041- 200000-300000	020000-100051- 200000-300000
	Cycle		030000-100000-200000-300000	030000-100000-200000-300000
	Installation 2		050000-100000-200000-300000	050000-100000-200000-300000



Product Specifications (cont.)

Model		Mini 4 way				
		IN	AC026RNNDKG/EU	AC035RNNDKG/EU	AC052RNNDKG/EU	AC071RNNDKG/EU
		OUT	AC026RXADKG/EU	AC035RXADKG/EU	AC052RXADKG/EU	AC071RXADKG/EU
Image	Indoor Unit					
	Outdoor unit					
	Remote controller					
Performance	cooling [W]	2.60	3.50	5.00	6.80	
	heating [W]	3.40	4.00	5.50	7.50	
Power Consumption	cooling [kW]	0.67	1.03	1.53	2.75	
	heating [kW]	0.92	1.20	1.52	2.80	
Voltage/Frequency [Ø, #, V, Hz]		1, 2, 220-240, 50	1, 2, 220-240, 50	1, 2, 220-240, 50	1, 2, 220-240, 50	
Operating Current	cooling [A]	3.5	5.0	7.0	12.	
	heating [A]	4.6	5.7	7.0	12.	
Noise	indoor unit (C/H) [dBA]	38/39	41/42	43/44	46/46	
	outdoor unit (C/H) [dBA]	51/51	53/53	58/58	60/60	
Size	net dimension (W*H*D)	indoor unit [mm]	575 x 250 x 575	575 x 250 x 575	575 x 250 x 575	575 x 250 x 575
		outdoor unit [mm]	790 x 548 x 285	790 x 548 x 285	880 x 638 x 310	880 x 798 x 310
	shipping dimension (W*H*D)	indoor unit [mm]	623 x 298 x 653	623 x 298 x 653	623 x 298 x 653	623 x 298 x 653
		outdoor unit [mm]	913 x 622 x 371	913 x 622 x 371	1023 x 742 x 413	1023 x 896 x 413
Weight	net weight	indoor unit [kg]	11.5	11.5	12.0	12.0
		outdoor unit [kg]	32.5	32.5	43.0	51.0
	shipping weight	indoor unit [kg]	14.0	14.0	14.2	14.2
		outdoor unit [kg]	35.5	35.5	46.5	55.0
Harness Specification	indoor fan motor	DB31-00578C	DB31-00578C	DB31-00578C	DB31-00578C	
	compressor	UB9AK5090FER	UB9AK5090FER	UB9TK3150FE4	UB4TN8200FE4	
	outdoor fan motor	DB31-00642C	DB31-00642C	DB31-00658D	DB31-00579A	
Designed Pressure	high pressure [Mpa]	4.1	4.1	4.1	4.1	
	low pressure [Mpa]	1.4	1.4	1.4	1.4	
Refrigerant/Factory charging [g]		R-32	R-32	R-32	R-32	
		900	900	1200	1700	
Additional refrigerant		0	0	15g/m over 10m	25g/m over 15m	
Basic piping length [m]		5	5	5	5	
Max.piping length [m]		20	20	30	50	
max.level difference [m]		15	15	20	30	
Option Code	Standard	01517F-1910C8-271A22-370000	01517F-1930F9-272328-370000	01517F-19345D-27343C-370040	01517F-194581-274750-370040	
	Installation 1	020000-100001-200000-300000	020000-100001-200000-300000	020000-100001-200000-300000	020000-100031-200000-300000	
	Cycle	030000-100000-200000-300000	030000-100000-200000-300000	030000-100000-200000-300000	030000-100000-200000-300000	
	Installation 2	050000-100000-200000-300000	050000-100000-200000-300000	050000-100000-200000-300000	050000-100000-200000-300000	



Product Specifications (cont.)

Model		4Way CST		
		IN	AC052RN4DKG/EU	AC071RN4DKG/EU
		OUT	AC052RXADKG/EU	AC071RXADKG/EU
Image	Indoor Unit			
	Outdoor unit			
	Remote controller			
Performance	cooling [W]		5.00	7.10
	heating [W]		6.00	8.00
Power Consumption	cooling [kW]		1.43	2.38
	heating [kW]		1.49	2.45
Voltage/Frequency [Ø, #, V, Hz]			1, 2, 220-240, 50	1, 2, 220-240, 50
Operating Current	cooling [A]		6.5	10.3
	heating [A]		6.8	10.7
Noise	indoor unit (C/H) [dBA]		42/42	43/43
	outdoor unit (C/H) [dBA]		58/58	60/60
Size	net dimension (W*H*D)	indoor unit [mm]	840 x 204 x 840	840 x 204 x 840
		outdoor unit [mm]	880 x 638 x 310	880 x 798 x 310
	shipping dimension (W*H*D)	indoor unit [mm]	898 x 275 x 898	898 x 275 x 898
		outdoor unit [mm]	1023 x 742 x 413	1023 x 896 x 413
Weight	net weight	indoor unit [kg]	14.5	14.5
		outdoor unit [kg]	43.0	51.0
	shipping weight	indoor unit [kg]	18.0	18.5
		outdoor unit [kg]	46.5	55.0
Harness Specification	indoor fan motor		DB31-00578B	DB31-00578B
	compressor		UB9TK3150FE4	UB4TN8200FE4
	outdoor fan motor		DB31-00658D	DB31-00579A
Designed Pressure	high pressure [Mpa]		4.1	4.1
	low pressure [Mpa]		1.4	1.4
Refrigerant/Factory charging [g]			R-32 1200	R-32 1700
Additional refrigerant			15g/m over 10m	25g/m over 15m
Basic piping length [m]			5	5
Max.piping length [m]			30	50
max.level difference [m]			20	30
Option Code	Standard		01417F-1940A8-27343C-370000	01417F-1940C8-274750-370000
	Installation 1		020000-100001-200000-300000	020000-100001-200000-300000
	Cycle		030000-100000-200000-300000	030000-100000-200000-300000
	Installation 2		050000-100000-200000-300000	050000-100000-200000-300000



Product Specifications (cont.)

Model		4Way CST			
		IN	AC100RN4DKG/EU	AC100RN4DKG/EU	
		OUT	AC100RXADKG/EU	AC100RXADNG/EU	
Image	Indoor Unit				
	Outdoor unit				
	Remote controller				
Performance	cooling [W]		10.00	10.00	
	heating [W]		11.20	11.20	
Power Consumption	cooling [kW]		3.42	3.32	
	heating [kW]		3.10	3.03	
Voltage/Frequency [Ø, #, V, Hz]			1, 2, 220-240, 50	3, 4, 380-415, 50	
Operating Current	cooling [A]		15.2	5.5	
	heating [A]		13.6	5.1	
Noise	indoor unit (C/H) [dBA]		48/48	48/48	
	outdoor unit (C/H) [dBA]		58/60	58/60	
Size	net dimension (W*H*D)	indoor unit [mm]	840 x 288 x 840	840 x 288 x 840	
		outdoor unit [mm]	940 x 998 x 330	940 x 998 x 330	
	shipping dimension (W*H*D)	indoor unit [mm]	898 x 357 x 898	898 x 357 x 898	
		outdoor unit [mm]	995 x 1096 x 426	995 x 1096 x 426	
Weight	net weight	indoor unit [kg]	18.0	18.0	
		outdoor unit [kg]	75.0	74.0	
	shipping weight	indoor unit [kg]	22.0	22.0	
		outdoor unit [kg]	80.0	79.0	
Harness Specification	indoor fan motor		DB31-00577A	DB31-00577A	
	compressor		UB8TN8300FJU	UB8TN8300FJU	
	outdoor fan motor		DB31-00579A	DB31-00579A	
Designed Pressure	high pressure [Mpa]		4.1	4.1	
	low pressure [Mpa]		1.4	1.4	
Refrigerant/Factory charging [g]			R-32	R-32	
			2700	2700	
Additional refrigerant			50g/m over 30m	50g/m over 30m	
Basic piping length [m]			5	5	
Max.piping length [m]			50	50	
max.level difference [m]			30	30	
Option Code	Standard		01417F-195429-276470-370040	01417F-195429-276470-370040	
	Installation 1		020000-100001-200000-300000	020000-100001-200000-300000	
	Cycle		030000-100000-200000-300000	030000-100000-200000-300000	
	Installation 2		050000-100000-200000-300000	050000-100000-200000-300000	



Product Specifications (cont.)

Model		4Way CST			
		IN	AC120RN4DKG/EU	AC120RN4DKG/EU	
		OUT	AC120RXADKG/EU	AC120RXADNG/EU	
Image	Indoor Unit				
	Outdoor unit				
	Remote controller				
Performance	cooling [W]		12.00	12.00	
	heating [W]		13.20	13.20	
Power Consumption	cooling [kW]		4.60	4.45	
	heating [kW]		4.15	4.05	
Voltage/Frequency [Ø, #, V, Hz]			1, 2, 220-240, 50	3, 4, 380-415, 50	
Operating Current	cooling [A]		20.1	6.8	
	heating [A]		18.2	6.3	
Noise	indoor unit (C/H) [dBA]		50/50	50/50	
	outdoor unit (C/H) [dBA]		59/61	59/61	
Size	net dimension (W*H*D)	indoor unit [mm]	840 x 288 x 840	840 x 288 x 840	
		outdoor unit [mm]	940 x 998 x 330	940 x 998 x 330	
	shipping dimension (W*H*D)	indoor unit [mm]	898 x 357 x 898	898 x 357 x 898	
		outdoor unit [mm]	995 x 1096 x 426	995 x 1096 x 426	
Weight	net weight	indoor unit [kg]	18.0	18.0	
		outdoor unit [kg]	81.0	80.0	
	shipping weight	indoor unit [kg]	22.0	22.0	
		outdoor unit [kg]	86.0	85.0	
Harness Specification	indoor fan motor		DB31-00577A	DB31-00577A	
	compressor		UB5TN5450FJX	UB5TN5450FJX	
	outdoor fan motor		DB31-00579A	DB31-00579A	
Designed Pressure	high pressure [Mpa]		4.1	4.1	
	low pressure [Mpa]		1.4	1.4	
Refrigerant/Factory charging [g]			R-32	R-32	
			2700	2700	
Additional refrigerant			50g/m over 30m	50g/m over 30m	
Basic piping length [m]			5	5	
Max.piping length [m]			50	50	
max.level difference [m]			30	30	
Option Code	Standard		01417F-19543A- 277882-370040	01417F-19543A- 277882-370040	
	Installation 1		020000-100001-200000-300000	020000-100001-200000-300000	
	Cycle		030000-100000-200000-300000	030000-100000-200000-300000	
	Installation 2		050000-100000-200000-300000	050000-100000-200000-300000	



Product Specifications (cont.)

Model		4Way CST		
		IN	AC140RN4DKG/EU	AC140RN4DKG/EU
		OUT	AC140RXADKG/EU	AC140RXADNG/EU
Image	Indoor Unit			
	Outdoor unit			
	Remote controller			
Performance	cooling [W]		13.40	13.40
	heating [W]		15.50	15.50
Power Consumption	cooling [kW]		4.62	4.62
	heating [kW]		4.90	4.76
Voltage/Frequency [Ø, #, V, Hz]			1, 2, 220-240, 50	3, 4, 380-415, 50
Operating Current	cooling [A]		20.0	7.1
	heating [A]		21.3	7.3
Noise	indoor unit (C/H) [dBA]		50/50	50/50
	outdoor unit (C/H) [dBA]		60/62	60/62
Size	net dimension (W*H*D)	indoor unit [mm]	840 x 288 x 840	840 x 288 x 840
		outdoor unit [mm]	940 x 1210 x 330	940 x 1210 x 330
	shipping dimension (W*H*D)	indoor unit [mm]	898 x 357 x 898	898 x 357 x 898
		outdoor unit [mm]	995 x 1388 x 426	995 x 1388 x 426
Weight	net weight	indoor unit [kg]	20.0	20.0
		outdoor unit [kg]	91.5	90.5
	shipping weight	indoor unit [kg]	24.0	24.0
		outdoor unit [kg]	100.0	99.0
Harness Specification	indoor fan motor		DB31-00577A	DB31-00577A
	compressor		UB5TN5450FJX	UB5TN5450FJX
	outdoor fan motor		DB31-00579A	DB31-00579A
Designed Pressure	high pressure [Mpa]		4.1	4.1
	low pressure [Mpa]		1.4	1.4
Refrigerant/Factory charging [g]			R-32	R-32
			2900	2900
Additional refrigerant			50g/m over 30m	50g/m over 30m
Basic piping length [m]			5	5
Max.piping length [m]			75	75
max.level difference [m]			30	30
Option Code	Standard		01417F-19543B-278CA0-370040	01417F-19543B-278CA0-370040
	Installation 1		020000-100001-200000-300000	020000-100001-200000-300000
	Cycle		030000-100000-200000-300000	030000-100000-200000-300000
	Installation 2		050000-100000-200000-300000	050000-100000-200000-300000



Product Specifications (cont.)

Model		360 CST	
		IN	AC071RN4PKG/EU
		OUT	AC071RXADKG/EU
Image	Indoor Unit		
	Outdoor unit		
	Remote controller		
Performance	cooling [W]		7.10
	heating [W]		8.00
Power Consumption	cooling [kW]		2.73
	heating [kW]		2.48
Voltage/Frequency [Ø, #, V, Hz]			1, 2, 220-240, 50
Operating Current	cooling [A]		11.8
	heating [A]		10.7
Noise	indoor unit (C/H) [dBA]		43/43
	outdoor unit (C/H) [dBA]		60/60
Size	net dimension (W*H*D)	indoor unit [mm]	947 x 281 x 947
		outdoor unit [mm]	880 x 798 x 310
	shipping dimension (W*H*D)	indoor unit [mm]	990 x 330 x 990
		outdoor unit [mm]	1023 x 896 x 413
Weight	net weight	indoor unit [kg]	20.2
		outdoor unit [kg]	51.0
	shipping weight	indoor unit [kg]	24.5
		outdoor unit [kg]	55.0
Harness Specification	indoor fan motor		DB31-00578E
	compressor		UB4TN8200FE4
	outdoor fan motor		DB31-00579A
Designed Pressure	high pressure [Mpa]		4.1
	low pressure [Mpa]		1.4
Refrigerant/Factory charging [g]			R-32
			1700
Additional refrigerant			25g/m over 15m
Basic piping length [m]			5
Max.piping length [m]			50
max.level difference [m]			30
Option Code	Standard		01017F-1940D8-274750-370000
	Installation 1		020000-100000-200000-300000
	Cycle		030000-100000-200000-300000
	Installation 2		050000-100000-200000-300000



Product Specifications (cont.)

Model		360 CST		
		IN	AC100RN4PKG/EU	AC100RN4PKG/EU
		OUT	AC100RXADKG/EU	AC100RXADKG/EU
Image	Indoor Unit			
	Outdoor unit			
	Remote controller			
Performance	cooling [W]		10.00	10.00
	heating [W]		11.20	11.20
Power Consumption	cooling [kW]		3.24	3.20
	heating [kW]		3.20	3.15
Voltage/Frequency [Ø, #, V, Hz]			1, 2, 220-240, 50	3, 4, 380-415, 50
Operating Current	cooling [A]		14.4	5.1
	heating [A]		14.2	5.0
Noise	indoor unit (C/H) [dBA]		50/50	50/50
	outdoor unit (C/H) [dBA]		58/60	58/60
Size	net dimension (W*H*D)	indoor unit [mm]	947 x 365 x 947	947 x 365 x 947
		outdoor unit [mm]	940 x 998 x 330	940 x 998 x 330
	shipping dimension (W*H*D)	indoor unit [mm]	990 x 414 x 990	990 x 414 x 990
		outdoor unit [mm]	995 x 1096 x 426	995 x 1096 x 426
Weight	net weight	indoor unit [kg]	23.5	23.5
		outdoor unit [kg]	75.0	74.0
	shipping weight	indoor unit [kg]	28.3	28.3
		outdoor unit [kg]	80.0	79.0
Harness Specification	indoor fan motor		DB31-00577D	DB31-00577D
	compressor		UB8TN8300FJU	UB8TN8300FJU
	outdoor fan motor		DB31-00579A	DB31-00579A
Designed Pressure	high pressure [Mpa]		4.1	4.1
	low pressure [Mpa]		1.4	1.4
Refrigerant/Factory charging [g]			R-32	R-32
			2700	2700
Additional refrigerant			50g/m over 30m	50g/m over 30m
Basic piping length [m]			5	5
Max.piping length [m]			50	50
max.level difference [m]			30	30
Option Code	Standard		01017F-19548C-276470-370040	01017F-19548C-276470-370040
	Installation 1		020000-100000-200000-300000	020000-100000-200000-300000
	Cycle		030000-100000-200000-300000	030000-100000-200000-300000
	Installation 2		050000-100000-200000-300000	050000-100000-200000-300000





Product Specifications (cont.)

Model		360 CST		
		IN	AC120RN4PKG/EU	AC120RN4PKG/EU
		OUT	AC120RXADKG/EU	AC120RXADNG/EU
Image	Indoor Unit			
	Outdoor unit			
	Remote controller			
Performance	cooling [W]		12.00	12.00
	heating [W]		13.20	13.20
Power Consumption	cooling [kW]		4.45	4.45
	heating [kW]		4.05	4.05
Voltage/Frequency [Ø, #, V, Hz]			1, 2, 220-240, 50	3, 4, 380-415, 50
Operating Current	cooling [A]		19.5	6.9
	heating [A]		17.7	6.3
Noise	indoor unit (C/H) [dBA]		50/50	50/50
	outdoor unit (C/H) [dBA]		59/61	59/61
Size	net dimension (W*H*D)	indoor unit [mm]	947 x 365 x 947	947 x 365 x 947
		outdoor unit [mm]	940 x 998 x 330	940 x 998 x 330
	shipping dimension (W*H*D)	indoor unit [mm]	990 x 414 x 990	990 x 414 x 990
		outdoor unit [mm]	995 x 1096 x 426	995 x 1096 x 426
Weight	net weight	indoor unit [kg]	23.5	23.5
		outdoor unit [kg]	81.0	80.0
	shipping weight	indoor unit [kg]	28.3	28.3
		outdoor unit [kg]	86.0	85.0
Harness Specification	indoor fan motor		DB31-00577D	DB31-00577D
	compressor		UB5TN5450FJX	UB5TN5450FJX
	outdoor fan motor		DB31-00579A	DB31-00579A
Designed Pressure	high pressure [Mpa]		4.1	4.1
	low pressure [Mpa]		1.4	1.4
Refrigerant/Factory charging [g]			R-32	R-32
			2700	2700
Additional refrigerant			50g/m over 30m	50g/m over 30m
Basic piping length [m]			5	5
Max.piping length [m]			50	50
max.level difference [m]			30	30
Option Code	Standard		01017F-19549D-277882-370040	01017F-19549D-277882-370040
	Installation 1		020000-100000-200000-300000	020000-100000-200000-300000
	Cycle		030000-100000-200000-300000	030000-100000-200000-300000
	Installation 2		050000-100000-200000-300000	050000-100000-200000-300000





Product Specifications (cont.)

Model		360 CST		
		IN	AC140RN4PKG/EU	AC140RN4PKG/EU
		OUT	AC140RXADKG/EU	AC140RXADNG/EU
Image	Indoor Unit			
	Outdoor unit			
	Remote controller			
Performance	cooling [W]		13.40	13.40
	heating [W]		15.50	15.50
Power Consumption	cooling [kW]		4.76	4.68
	heating [kW]		4.62	4.54
Voltage/Frequency [Ø, #, V, Hz]			1, 2, 220-240, 50	3, 4, 380-415, 50
Operating Current	cooling [A]		20.6	7.3
	heating [A]		20.0	7.1
Noise	indoor unit (C/H) [dBA]		51/51	51/51
	outdoor unit (C/H) [dBA]		60/62	60/62
Size	net dimension (W*H*D)	indoor unit [mm]	947 x 365 x 947	947 x 365 x 947
		outdoor unit [mm]	940 x 1210 x 330	940 x 1210 x 330
	shipping dimension (W*H*D)	indoor unit [mm]	990 x 414 x 990	990 x 414 x 990
		outdoor unit [mm]	995 x 1388 x 426	995 x 1388 x 426
Weight	net weight	indoor unit [kg]	25.5	25.5
		outdoor unit [kg]	91.5	90.5
	shipping weight	indoor unit [kg]	30.3	30.3
		outdoor unit [kg]	100.0	99.0
Harness Specification	indoor fan motor		DB31-00577D	DB31-00577D
	compressor		UB5TN5450FJX	UB5TN5450FJX
	outdoor fan motor		DB31-00579A	DB31-00579A
Designed Pressure	high pressure [Mpa]		4.1	4.1
	low pressure [Mpa]		1.4	1.4
Refrigerant/Factory charging [g]			R-32	R-32
			2900	2900
Additional refrigerant			50g/m over 30m	50g/m over 30m
Basic piping length [m]			5	5
Max.piping length [m]			75	75
max.level difference [m]			30	30
Option Code	Standard		01117F-1954AF-278CA0-370040	01117F-1954AF-278CA0-370040
	Installation 1		020000-100000-200000-300000	020000-100000-200000-300000
	Cycle		030000-100000-200000-300000	030000-100000-200000-300000
	Installation 2		050000-100000-200000-300000	050000-100000-200000-300000



Product Specifications (cont.)

Model		LSP Duct				
		IN	AC026RNLDKG/EU	AC035RNLDKG/EU	AC052RNLDKG/EU	AC071RNLDKG/EU
		OUT	AC026RXADKG/EU	AC035RXADKG/EU	AC052RXADKG/EU	AC071RXADKG/EU
Image	Indoor Unit					
	Outdoor unit					
	Remote controller					
Performance	cooling [W]		2.60	3.50	5.00	7.10
	heating [W]		3.30	4.00	6.00	8.00
Power Consumption	cooling [kW]		0.68	1.12	1.69	2.38
	heating [kW]		0.87	1.21	1.74	2.38
Voltage/Frequency [Ø, #, V, Hz]			1, 2, 220-240, 50	1, 2, 220-240, 50	1, 2, 220-240, 50	1, 2, 220-240, 50
Operating Current	cooling [A]		3.6	5.4	7.7	10.5
	heating [A]		4.5	5.8	7.8	10.4
Noise	indoor unit (C/H) [dBA]		40/40	40/40	45/45	47/47
	outdoor unit (C/H) [dBA]		51/51	53/53	58/58	60/60
Size	net dimension (W*H*D)	indoor unit [mm]	700 x 199 x 600	700 x 199 x 600	1100 x 200 x 450	1100 x 200 x 450
		outdoor unit [mm]	790 x 548 x 285	790 x 548 x 285	880 x 638 x 310	880 x 798 x 310
	shipping dimension (W*H*D)	indoor unit [mm]	951 x 280 x 709	951 x 280 x 709	1319 x 270 x 529	1319 x 270 x 529
		outdoor unit [mm]	913 x 622 x 371	913 x 622 x 371	1023 x 742 x 413	1023 x 896 x 413
Weight	net weight	indoor unit [kg]	19.0	19.0	23.5	23.5
		outdoor unit [kg]	32.5	32.5	43.0	51.0
	shipping weight	indoor unit [kg]	23.0	23.0	27.0	27.0
		outdoor unit [kg]	35.5	35.5	46.5	55.0
Harness Specification	indoor fan motor		DB31-00653A	DB31-00653A	DB31-00638A	DB31-00638A
	compressor		UB9AK5090FER	UB9AK5090FER	UB9TK3150FE4	UB4TN8200FE4
	outdoor fan motor		DB31-00642C	DB31-00642C	DB31-00658D	DB31-00579A
Designed Pressure	high pressure [Mpa]		4.1	4.1	4.1	4.1
	low pressure [Mpa]		1.4	1.4	1.4	1.4
Refrigerant/Factory charging [g]			R-32 900	R-32 900	R-32 1200	R-32 1700
Additional refrigerant			0	0	15g/m over 10m	25g/m over 15m
Basic piping length [m]			5	5	5	5
Max.piping length [m]			20	20	30	50
max.level difference [m]			15	15	20	30
Option Code	Standard		01C17C-1C1914-271A21-370000	01C17C-1C3936-272328-370000	01C17C-1C1924-27343C-370000	01C17C-1C59D0-274750-370005
	Installation 1		020000-100000-200000-300000	020000-100000-200000-300000	020000-100000-200000-300000	020000-100000-200000-300000
	Cycle		030000-100000-200000-300000	030000-100000-200000-300000	030000-100000-200000-300000	030000-100000-200000-300000
	Installation 2		050000-100000-200000-300000	050000-100000-200000-300000	050000-100000-200000-300000	050000-100000-200000-300000



Product Specifications (cont.)

Model		MSP Duct			
		IN	AC035RNMDKG/EU	AC052RNMDKG/EU	AC071RNMDKG/EU
		OUT	AC035RXADKG/EU	AC052RXADKG/EU	AC071RXADKG/EU
Image	Indoor Unit				
	Outdoor unit				
	Remote controller				
Performance	cooling [W]		3.50	5.00	6.80
	heating [W]		4.00	6.00	8.00
Power Consumption	cooling [kW]		1.02	1.60	2.32
	heating [kW]		1.15	1.64	2.50
Voltage/Frequency [Ø, #, V, Hz]			1, 2, 220-240, 50	1, 2, 220-240, 50	1, 2, 220-240, 50
Operating Current	cooling [A]		5.0	7.2	10.4
	heating [A]		5.4	7.4	10.8
Noise	indoor unit (C/H) [dBA]		40/40	45/45	47/47
	outdoor unit (C/H) [dBA]		53/53	58/58	60/60
Size	net dimension (W*H*D)	indoor unit [mm]	850 x 250 x 700	850 x 250 x 700	850 x 250 x 700
		outdoor unit [mm]	790 x 548 x 285	880 x 638 x 310	880 x 798 x 310
	shipping dimension (W*H*D)	indoor unit [mm]	1064 x 320 x 784	1064 x 320 x 784	1064 x 320 x 784
		outdoor unit [mm]	913 x 622 x 371	1023 x 742 x 413	1023 x 896 x 413
Weight	net weight	indoor unit [kg]	26.5	26.5	26.5
		outdoor unit [kg]	32.5	43.0	51.0
	shipping weight	indoor unit [kg]	30.5	30.5	30.5
		outdoor unit [kg]	35.5	46.5	55.0
Harness Specification	indoor fan motor		DB31-00639B	DB31-00639B	DB31-00639B
	compressor		UB9AK5090FER	UB9TK3150FE4	UB4TN8200FE4
	outdoor fan motor		DB31-00642C	DB31-00658D	DB31-00579A
Designed Pressure	high pressure [Mpa]		4.1	4.1	4.1
	low pressure [Mpa]		1.4	1.4	1.4
Refrigerant/Factory charging [g]			R-32 900	R-32 1200	R-32 1700
Additional refrigerant			0	15g/m over 10m	25g/m over 15m
Basic piping length [m]			5	5	5
Max.piping length [m]			20	30	50
max.level difference [m]			15	20	30
Option Code	Standard		01B17C-1C5080-272328-372008	01B17C-1C50F1-27343C-374000	01B17C-1C5436-274750-376000
	Installation 1		020000-100000-200000-300000	020000-100000-200000-300000	020000-100000-200000-300000
	Cycle		030000-100000-200000-300000	030000-100000-200000-300000	030000-100000-200000-300000
	Installation 2		050000-100000-200000-300000	050000-100000-200000-300000	050000-100000-200000-300000



Product Specifications (cont.)

Model		MSP Duct		
		IN	AC100RNMDKG/EU	AC100RNMDKG/EU
		OUT	AC100RXADKG/EU	AC100RXADNG/EU
Image	Indoor Unit			
	Outdoor unit			
	Remote controller			
Performance	cooling [W]		10.00	10.00
	heating [W]		11.20	11.20
Power Consumption	cooling [kW]		3.44	3.42
	heating [kW]		3.50	3.42
Voltage/Frequency [Ø, #, V, Hz]			1, 2, 220-240, 50	3, 4, 380-415, 50
Operating Current	cooling [A]		15.2	5.3
	heating [A]		15.4	5.3
Noise	indoor unit (C/H) [dBA]		45/46	45/46
	outdoor unit (C/H) [dBA]		58/60	58/60
Size	net dimension (W*H*D)	indoor unit [mm]	1200 x 250 x 700	1200 x 250 x 700
		outdoor unit [mm]	940 x 998 x 330	940 x 998 x 330
	shipping dimension (W*H*D)	indoor unit [mm]	1429 x 320 x 779	1429 x 320 x 779
		outdoor unit [mm]	995 x 1096 x 426	995 x 1096 x 426
Weight	net weight	indoor unit [kg]	34.0	34.0
		outdoor unit [kg]	75.0	74.0
	shipping weight	indoor unit [kg]	39.0	39.0
		outdoor unit [kg]	80.0	79.0
Harness Specification	indoor fan motor		DB31-00640B	DB31-00640B
	compressor		UB8TN8300FJU	UB8TN8300FJU
	outdoor fan motor		DB31-00579A	DB31-00579A
Designed Pressure	high pressure [Mpa]		4.1	4.1
	low pressure [Mpa]		1.4	1.4
Refrigerant/Factory charging [g]			R-32 2700	R-32 2700
Additional refrigerant			50g/m over 30m	50g/m over 30m
Basic piping length [m]			5	5
Max.piping length [m]			50	50
max.level difference [m]			30	30
Option Code	Standard		01B17C-1C549F-276470-375020	01B17C-1C549F-276470-375020
	Installation 1		020000-100000-200000-300000	020000-100000-200000-300000
	Cycle		030000-100000-200000-300000	030000-100000-200000-300000
	Installation 2		050000-100000-200000-300000	050000-100000-200000-300000





Product Specifications (cont.)

Model		MSP Duct		
		IN	AC120RNMDKG/EU	AC120RNMDKG/EU
		OUT	AC120RXADKG/EU	AC120RXADNG/EU
Image	Indoor Unit			
	Outdoor unit			
	Remote controller			
Performance	cooling [W]		12.00	12.00
	heating [W]		13.20	13.20
Power Consumption	cooling [kW]		4.50	4.48
	heating [kW]		3.86	3.79
Voltage/Frequency [Ø, #, V, Hz]			1, 2, 220-240, 50	3, 4, 380-415, 50
Operating Current	cooling [A]		19.7	6.9
	heating [A]		17.1	5.9
Noise	indoor unit (C/H) [dBA]		46/47	46/47
	outdoor unit (C/H) [dBA]		59/61	59/61
Size	net dimension (W*H*D)	indoor unit [mm]	1300 x 300 x 700	1300 x 300 x 700
		outdoor unit [mm]	940 x 998 x 330	940 x 998 x 330
	shipping dimension (W*H*D)	indoor unit [mm]	1529 x 370 x 779	1529 x 370 x 779
		outdoor unit [mm]	995 x 1096 x 426	995 x 1096 x 426
Weight	net weight	indoor unit [kg]	38.5	38.5
		outdoor unit [kg]	81.0	80.0
	shipping weight	indoor unit [kg]	45.0	45.0
		outdoor unit [kg]	86.0	85.0
Harness Specification	indoor fan motor		DB31-00641B	DB31-00641B
	compressor		UB5TN5450FJX	UB5TN5450FJX
	outdoor fan motor		DB31-00579A	DB31-00579A
Designed Pressure	high pressure [Mpa]		4.1	4.1
	low pressure [Mpa]		1.4	1.4
Refrigerant/Factory charging [g]			R-32 2700	R-32 2700
Additional refrigerant			50g/m over 30m	50g/m over 30m
Basic piping length [m]			5	5
Max.piping length [m]			50	50
max.level difference [m]			30	30
Option Code	Standard		01B17C-1C5424-277882-374040	01B17C-1C5424-277882-374040
	Installation 1		020000-100000-200000-300000	020000-100000-200000-300000
	Cycle		030000-100000-200000-300000	030000-100000-200000-300000
	Installation 2		050000-100000-200000-300000	050000-100000-200000-300000



Product Specifications (cont.)

Model		MSP Duct		
		IN	AC140RNMDKG/EU	AC140RNMDKG/EU
		OUT	AC140RXADKG/EU	AC140RXADNG/EU
Image	Indoor Unit			
	Outdoor unit			
	Remote controller			
Performance	cooling [W]		13.40	13.40
	heating [W]		15.50	15.50
Power Consumption	cooling [kW]		4.62	4.62
	heating [kW]		4.64	4.51
Voltage/Frequency [Ø, #, V, Hz]		1, 2, 220-240, 50		3, 4, 380-415, 50
Operating Current	cooling [A]		20.0	7.1
	heating [A]		20.0	7.0
Noise	indoor unit (C/H) [dBA]		47/48	47/48
	outdoor unit (C/H) [dBA]		60/62	60/62
Size	net dimension (W*H*D)	indoor unit [mm]	1300 x 300 x 700	1300 x 300 x 700
		outdoor unit [mm]	940 x 1210 x 330	940 x 1210 x 330
	shipping dimension (W*H*D)	indoor unit [mm]	1529 x 370 x 779	1529 x 370 x 779
		outdoor unit [mm]	995 x 1388 x 426	995 x 1388 x 426
Weight	net weight	indoor unit [kg]	38.5	38.5
		outdoor unit [kg]	91.5	90.5
	shipping weight	indoor unit [kg]	45.0	45.0
		outdoor unit [kg]	100.0	99.0
Harness Specification	indoor fan motor		DB31-00641B	DB31-00641B
	compressor		UB5TN5450FJX	UB5TN5450FJX
	outdoor fan motor		DB31-00579A	DB31-00579A
Designed Pressure	high pressure [Mpa]		4.1	4.1
	low pressure [Mpa]		1.4	1.4
Refrigerant/Factory charging [g]		R-32		R-32
		2900		2900
Additional refrigerant		50g/m over 30m		50g/m over 30m
Basic piping length [m]		5		5
Max.piping length [m]		75		75
max.level difference [m]		30		30
Option Code	Standard		01B17C-1C5424-278CA0-374045	01B17C-1C5424-278CA0-374045
	Installation 1		020000-100000-200000-300000	020000-100000-200000-300000
	Cycle		030000-100000-200000-300000	030000-100000-200000-300000
	Installation 2		050000-100000-200000-300000	050000-100000-200000-300000





Product Specifications (cont.)

Model		C-RAC				
		IN	AC026RNADKG/EU	AC035RNADKG/EU	AC052RNADKG/EU	AC071RNADKG/EU
		OUT	AC026RXADKG/EU	AC035RXADKG/EU	AC052RXADKG/EU	AC071RXADKG/EU
Image	Indoor Unit					
	Outdoor unit					
	Remote controller					
Performance	cooling [W]	2.60	3.50	5.00	7.10	
	heating [W]	3.30	4.00	6.00	8.00	
Power Consumption	cooling [kW]	0.74	1.10	2.20	2.35	
	heating [kW]	1.10	1.55	2.15	2.45	
Voltage/Frequency [Ø, #, V, Hz]		1, 2, 220-240, 50	1, 2, 220-240, 50	1, 2, 220-240, 50	1, 2, 220-240, 50	
Operating Current	cooling [A]	3.7	5.3	9.6	10.3	
	heating [A]	5.1	6.9	9.4	10.7	
Noise	indoor unit (C/H) [dBA]	43/43	43/43	48/48	51/51	
	outdoor unit (C/H) [dBA]	51/51	53/53	58/58	60/60	
Size	net dimension (W*H*D)	indoor unit [mm]	750 x 249 x 246	750 x 249 x 246	896 x 261 x 261	1065 x 294 x 301
		outdoor unit [mm]	790 x 548 x 285	790 x 548 x 285	880 x 638 x 310	880 x 798 x 310
	shipping dimension (W*H*D)	indoor unit [mm]	800 x 298 x 302	800 x 298 x 302	956 x 317 x 335	1123 x 354 x 384
		outdoor unit [mm]	913 x 622 x 371	913 x 622 x 371	1023 x 742 x 413	1023 x 896 x 413
Weight	net weight	indoor unit [kg]	7.6	7.6	10.8	14.4
		outdoor unit [kg]	32.5	32.5	43.0	51.0
	shipping weight	indoor unit [kg]	9	9	12.6	16.8
		outdoor unit [kg]	35.5	35.5	46.5	55.0
Harness Specification	indoor fan motor	DB31-00636A	DB31-00636A	DB31-00636A	DB31-00637A	
	compressor	UB9AK5090FER	UB9AK5090FER	UB9TK3150FE4	UB4TN8200FE4	
	outdoor fan motor	DB31-00642C	DB31-00642C	DB31-00658D	DB31-00579A	
Designed Pressure	high pressure [Mpa]	4.1	4.1	4.1	4.1	
	low pressure [Mpa]	1.4	1.4	1.4	1.4	
Refrigerant/Factory charging [g]		R-32	R-32	R-32	R-32	
		900	900	1200	1700	
Additional refrigerant		0	0	15g/m over 10m	25g/m over 15m	
Basic piping length [m]		5	5	5	5	
Max.piping length [m]		20	20	30	50	
max.level difference [m]		15	15	20	30	
Option Code	Standard	01017F-191448-271A21-371700	01017F-19548C-272328-371700	01017F-19548E-27343C-371700	01017F-19547F-274750-371700	
	Installation 1	020000-100000-200100-300000	020000-100000-200100-300000	020000-100000-200100-300000	020000-100000-200100-300000	
	Cycle	030000-100000-200000-300000	030000-100000-200000-300000	030000-100000-200000-300000	030000-100000-200000-300000	
	Installation 2	050000-100000-200000-300000	050000-100000-200000-300000	050000-100000-200000-300000	050000-100000-200000-300000	

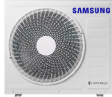

Product Specifications (cont.)

Model		C-RAC		
		IN	AC100RNTDKG/EU	AC100RNTDKG/EU
		OUT	AC100RXADKG/EU	AC100RXADNG/EU
Image	Indoor Unit			
	Outdoor unit			
	Remote controller			
Performance	cooling [W]		9.50	9.50
	heating [W]		10.80	10.80
Power Consumption	cooling [kW]		3.75	3.62
	heating [kW]		3.82	3.62
Voltage/Frequency [Ø, #, V, Hz]			1, 2, 220-240, 50	3, 4, 380-415, 50
Operating Current	cooling [A]		16.3	5.7
	heating [A]		16.7	5.7
Noise	indoor unit (C/H) [dBA]		55/55	55/55
	outdoor unit (C/H) [dBA]		60/62	60/62
Size	net dimension (W*H*D)	indoor unit [mm]	1280 x 253 x 345	1280 x 253 x 345
		outdoor unit [mm]	940 x 998 x 330	940 x 998 x 330
	shipping dimension (W*H*D)	indoor unit [mm]	1352 x 326 x 420	1352 x 326 x 420
		outdoor unit [mm]	995 x 1096 x 426	995 x 1096 x 426
Weight	net weight	indoor unit [kg]	18.5	18.5
		outdoor unit [kg]	75.0	74.0
	shipping weight	indoor unit [kg]	22.0	22.0
		outdoor unit [kg]	80.0	79.0
Harness Specification	indoor fan motor		DB31-00332C	DB31-00332C
	compressor		UB8TN8300FJU	UB8TN8300FJU
	outdoor fan motor		DB31-00579A	DB31-00579A
Designed Pressure	high pressure [Mpa]		4.1	4.1
	low pressure [Mpa]		1.4	1.4
Refrigerant/Factory charging [g]			R-32	R-32
			2700	2700
Additional refrigerant			50g/m over 30m	50g/m over 30m
Basic piping length [m]			5	5
Max.piping length [m]			50	50
max.level difference [m]			30	30
Option Code	Standard		01117F-193570-27646C-371700	01117F-193570-27646C-371700
	Installation 1		020000-100000-200000-300000	020000-100000-200000-300000
	Cycle		030000-100000-200000-300000	030000-100000-200000-300000
	Installation 2		050000-100000-200000-300000	050000-100000-200000-300000



Product Specifications (cont.)

Model		Ceiling		
		IN	AC052RNCDKG/EU	AC071RNCDKG/EU
		OUT	AC052RXADKG/EU	AC071RXADKG/EU
Image	Indoor Unit			
	Outdoor unit			
	Remote controller			
Performance	cooling [W]	5.00	7.10	
	heating [W]	6.00	8.00	
Power Consumption	cooling [kW]	1.58	2.87	
	heating [kW]	1.92	3.05	
Voltage/Frequency [Ø, #, V, Hz]		1, 2, 220-240, 50	1, 2, 220-240, 50	
Operating Current	cooling [A]	7.2	12.4	
	heating [A]	8.5	13.2	
Noise	indoor unit (C/H) [dBA]	49/49	51/51	
	outdoor unit (C/H) [dBA]	58/58	60/60	
Size	net dimension (W*H*D)	indoor unit [mm]	1000 x 200 x 650	1000 x 200 x 650
		outdoor unit [mm]	880 x 638 x 310	880 x 798 x 310
	shipping dimension (W*H*D)	indoor unit [mm]	1074 x 294 x 726	1074 x 294 x 726
		outdoor unit [mm]	1023 x 742 x 413	1023 x 896 x 413
Weight	net weight	indoor unit [kg]	20	20
		outdoor unit [kg]	43.0	51.0
	shipping weight	indoor unit [kg]	25.0	25.0
		outdoor unit [kg]	46.5	55.0
Harness Specification	indoor fan motor	DB31-00646B	DB31-00646B	
	compressor	UB9TK3150FE4	UB4TN8200FE4	
	outdoor fan motor	DB31-00658D	DB31-00579A	
Designed Pressure	high pressure [Mpa]	4.1	4.1	
	low pressure [Mpa]	1.4	1.4	
Refrigerant/Factory charging [g]		R-32	R-32	
		1200	1700	
Additional refrigerant		15g/m over 10m	25g/m over 15m	
Basic piping length [m]		5	5	
Max.piping length [m]		30	50	
max.level difference [m]		20	30	
Option Code	Standard	01317F-1950F5-27343C-370000	01317F-195591-274750-370020	
	Installation 1	020000-100000-200000-300000	020000-100000-200000-300000	
	Cycle	030000-100000-200000-300000	030000-100000-200000-300000	
	Installation 2	050000-100000-200000-300000	050000-100000-200000-300000	



Product Specifications (cont.)

Model		Big Ceiling		
		IN	AC100RNCDKG/EU	AC100RNCDKG/EU
		OUT	AC100RXADKG/EU	AC100RXADNG/EU
Image	Indoor Unit			
	Outdoor unit			
	Remote controller			
Performance	cooling [W]		10.00	10.00
	heating [W]		11.20	11.20
Power Consumption	cooling [kW]		3.28	3.15
	heating [kW]		3.25	3.20
Voltage/Frequency [Ø, #, V, Hz]			1, 2, 220-240, 50	3, 4, 380-415, 50
Operating Current	cooling [A]		14.6	5.0
	heating [A]		14.2	5.1
Noise	indoor unit (C/H) [dBA]		47/47	47/47
	outdoor unit (C/H) [dBA]		58/60	58/60
Size	net dimension (W*H*D)	indoor unit [mm]	1650 x 235 x 675	1650 x 235 x 675
		outdoor unit [mm]	940 x 998 x 330	940 x 998 x 330
	shipping dimension (W*H*D)	indoor unit [mm]	1739 x 321 x 758	1739 x 321 x 758
		outdoor unit [mm]	995 x 1096 x 426	995 x 1096 x 426
Weight	net weight	indoor unit [kg]	42.0	42.0
		outdoor unit [kg]	75.0	74.0
	shipping weight	indoor unit [kg]	48.0	48.0
		outdoor unit [kg]	80.0	79.0
Harness Specification	indoor fan motor		DB31-00661B	DB31-00661B
	compressor		UB8TN8300FJU	UB8TN8300FJU
	outdoor fan motor		DB31-00579A	DB31-00579A
Designed Pressure	high pressure [Mpa]		4.1	4.1
	low pressure [Mpa]		1.4	1.4
Refrigerant/Factory charging [g]			R-32 2700	R-32 2700
Additional refrigerant			50g/m over 30m	50g/m over 30m
Basic piping length [m]			5	5
Max.piping length [m]			50	50
max.level difference [m]			30	30
Option Code	Standard		01D17C-1C5439-276470-370042	01D17C-1C5439-276470-370042
	Installation 1		020000-100000-200000-300000	020000-100000-200000-300000
	Cycle		030000-100000-200000-300000	030000-100000-200000-300000
	Installation 2		050000-100000-200000-300000	050000-100000-200000-300000





Product Specifications (cont.)

Model		Big Ceiling		
		IN	AC120RNCDKG/EU	AC120RNCDKG/EU
		OUT	AC120RXADKG/EU	AC120RXADNG/EU
Image	Indoor Unit			
	Outdoor unit			
	Remote controller			
Performance	cooling [W]		12.00	12.00
	heating [W]		13.20	13.20
Power Consumption	cooling [kW]		4.35	4.15
	heating [kW]		3.83	3.80
Voltage/Frequency [Ø, #, V, Hz]			1, 2, 220-240, 50	3, 4, 380-415, 50
Operating Current	cooling [A]		19.1	6.6
	heating [A]		17.0	6.2
Noise	indoor unit (C/H) [dBA]		50/50	50/50
	outdoor unit (C/H) [dBA]		59/61	59/61
Size	net dimension (W*H*D)	indoor unit [mm]	1650 x 235 x 675	1650 x 235 x 675
		outdoor unit [mm]	940 x 998 x 330	940 x 998 x 330
	shipping dimension (W*H*D)	indoor unit [mm]	1739 x 321 x 758	1739 x 321 x 758
		outdoor unit [mm]	995 x 1096 x 426	995 x 1096 x 426
Weight	net weight	indoor unit [kg]	42.0	42.0
		outdoor unit [kg]	81.0	80.0
	shipping weight	indoor unit [kg]	48.0	48.0
		outdoor unit [kg]	86.0	85.0
Harness Specification	indoor fan motor		DB31-00661B	DB31-00661B
	compressor		UB5TN5450FJX	UB5TN5450FJX
	outdoor fan motor		DB31-00579A	DB31-00579A
Designed Pressure	high pressure [Mpa]		4.1	4.1
	low pressure [Mpa]		1.4	1.4
Refrigerant/Factory charging [g]			R-32 2700	R-32 2700
Additional refrigerant			50g/m over 30m	50g/m over 30m
Basic piping length [m]			5	5
Max.piping length [m]			50	50
max.level difference [m]			30	30
Option Code	Standard		01D17C-1C247A-277882-370040	01D17C-1C247A-277882-370040
	Installation 1		020000-100000-200000-300000	020000-100000-200000-300000
	Cycle		030000-100000-200000-300000	030000-100000-200000-300000
	Installation 2		050000-100000-200000-300000	050000-100000-200000-300000

Product Specifications (cont.)

Model		Big Ceiling		
		IN	AC140RNCDKG/EU	AC140RNCDKG/EU
		OUT	AC140RXADKG/EU	AC140RXADNG/EU
Image	Indoor Unit			
	Outdoor unit			
	Remote controller			
Performance	cooling [W]		13.40	13.40
	heating [W]		15.50	15.50
Power Consumption	cooling [kW]		4.50	4.50
	heating [kW]		4.54	4.54
Voltage/Frequency [Ø, #, V, Hz]			1, 2, 220-240, 50	3, 4, 380-415, 50
Operating Current	cooling [A]		19.7	7.0
	heating [A]		19.8	7.0
Noise	indoor unit (C/H) [dBA]		51/51	51/51
	outdoor unit (C/H) [dBA]		60/62	60/62
Size	net dimension (W*H*D)	indoor unit [mm]	1650 x 235 x 675	1650 x 235 x 675
		outdoor unit [mm]	940 x 1210 x 330	940 x 1210 x 330
	shipping dimension (W*H*D)	indoor unit [mm]	1739 x 321 x 758	1739 x 321 x 758
		outdoor unit [mm]	995 x 1388 x 426	995 x 1388 x 426
Weight	net weight	indoor unit [kg]	42.0	42.0
		outdoor unit [kg]	91.5	90.5
	shipping weight	indoor unit [kg]	48.0	48.0
		outdoor unit [kg]	100.0	99.0
Harness Specification	indoor fan motor		DB31-00661B	DB31-00661B
	compressor		UB5TN5450FJX	UB5TN5450FJX
	outdoor fan motor		DB31-00579A	DB31-00579A
Designed Pressure	high pressure [Mpa]		4.1	4.1
	low pressure [Mpa]		1.4	1.4
Refrigerant/Factory charging [g]			R-32 2900	R-32 2900
Additional refrigerant			50g/m over 30m	50g/m over 30m
Basic piping length [m]			5	5
Max.piping length [m]			75	75
max.level difference [m]			30	30
Option Code	Standard		01D17C-1C54BE-278CA0-370045	01D17C-1C54BE-278CA0-370045
	Installation 1		020000-100000-200000-300000	020000-100000-200000-300000
	Cycle		030000-100000-200000-300000	030000-100000-200000-300000
	Installation 2		050000-100000-200000-300000	050000-100000-200000-300000











Product Specifications (cont.)

Model		Console			
		IN	AC026RNJDKG/EU	AC035RNJDKG/EU	AC052RNJDKG/EU
		OUT	AC026RXADKG/EU	AC035RXADKG/EU	AC052RXADKG/EU
Image	Indoor Unit				
	Outdoor unit				
	Remote controller				
Performance	cooling [W]	2.60	3.50	5.00	
	heating [W]	3.50	4.00	5.60	
Power Consumption	cooling [kW]	0.72	1.12	1.79	
	heating [kW]	1.06	1.30	1.86	
Voltage/Frequency [Ø, #, V, Hz]		1, 2, 220-240, 50	1, 2, 220-240, 50	1, 2, 220-240, 50	
Operating Current	cooling [A]	3.6	5.5	8.0	
	heating [A]	5.0	5.9	8.3	
Noise	indoor unit (C/H) [dBA]	41/43	42/44	47/49	
	outdoor unit (C/H) [dBA]	51/51	53/53	58/58	
Size	net dimension (W*H*D)	indoor unit [mm]	720 x 199 x 620	720 x 199 x 620	720 x 199 x 620
		outdoor unit [mm]	790 x 548 x 285	790 x 548 x 285	880 x 638 x 310
	shipping dimension (W*H*D)	indoor unit [mm]	805 x 297 x 705	805 x 297 x 705	805 x 297 x 705
		outdoor unit [mm]	913 x 622 x 371	913 x 622 x 371	1023 x 742 x 413
Weight	net weight	indoor unit [kg]	16.0	16.0	16.0
		outdoor unit [kg]	32.5	32.5	43.0
	shipping weight	indoor unit [kg]	20.5	20.5	21.0
		outdoor unit [kg]	35.5	35.5	46.5
Harness Specification	indoor fan motor	DB31-00517A	DB31-00517A	DB31-00517A	
	compressor	UB9AK5090FER	UB9AK5090FER	UB9TK3150FE4	
	outdoor fan motor	DB31-00642C	DB31-00642C	DB31-00658D	
Designed Pressure	high pressure [Mpa]	4.1	4.1	4.1	
	low pressure [Mpa]	1.4	1.4	1.4	
Refrigerant/Factory charging [g]		R-32	R-32	R-32	
		900	900	1200	
Additional refrigerant		0	0	15g/m over 10m	
Basic piping length [m]		5	5	5	
Max.piping length [m]		20	20	30	
max.level difference [m]		15	15	20	
Option Code	Standard	01917F-1930B6-271A23-370560	01917F-1930D8-272328-370660	01917F-1910F9-27343C-370610	
	Installation 1	020000-100000-200000-300000	020000-100000-200000-300000	020000-100000-200000-300000	
	Cycle	030000-100000-200000-300008	030000-100000-200000-300008	030000-100000-200000-300008	
	Installation 2	050000-100000-200000-300000	050000-100000-200000-300000	050000-100000-200000-300000	

2-6 Specifications of optional items







2-6-1 Accessories

■ AC***RN4DKG

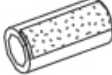
Item	Description	Code No.	Q'ty	Remark
	Ass'y drain hose	DB94-02719B	1	Indoor Unit
	Cable-tie	DB65-00191A	6	
	Seal-drain ass'y	DB62-05810A	1	
	Seal-drain ass'y	DB62-05810F	1	
	Seal-drain ass'y	DB62-05810G	1	
	CARD WARRANTY	DB68-02596B	1	
	User Manual	DB68-08166A	1	
	Installation Manual	DB68-08158A	1	
	BOLT-FLANGE	6011-003975	4	
	Installation Manual	DB68-07705A	1	
	CARD WARRANTY	DB68-02596B	1	

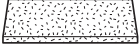

Accessories (cont.)

■ AC***RN1DKG

Item	Description	Code No.	Q'ty	Remark
	PAD INSTALL	DB69-01947A, B	1	Indoor Unit
	SEAL-DRAIN ASSY	DB62-05810A	1	
	HOSE DRAIN-JOINT	DB94-01258C	1	
	GROMMET-HANGER	DB63-00237A	8	
	MANUAL INSTALL	DB68-08158A	1	
	MANUAL USERS	DB68-08166A	1	
	INSULATION-BASE	DB72-00401C	2	
	CABLE TIE	DB65-10088C	3	
	CARD WARRANTY	DB68-02596B	1	





Accessories (cont.)

■ AC***RNNDKG

Item	Description	Code No.	Q'ty	Remark
	Ass'y drain hose	DB94-03287A	1	Essential Offer (Indoor Unit)
	Cable-tie	DB65-10088C	6	
	Seal-drain ass'y	DB62-11028A	1	
	Seal-drain ass'y	DB62-11028H	1	
	Seal-drain ass'y	DB62-11028J	1	
	USER MANUAL INSTALLATION MANUAL	DB68-08128A DB68-08129A	1	
	CARD WARRANTY	DB68-02596B	1	
	BOLT	6011-003975	4	Essential Offer (Panel)
	INSTALLATION MANUAL	DB68-03837A	1	

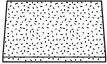
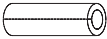
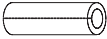
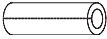





Accessories (cont.)

■ AC***RNLDKG, AC***RNMDKG

Item	Description	Code No.	Q'ty	Remark
	USER MANUAL INSTALLATION MANUAL	DB68-08130A DB68-08131A	1	Indoor Unit
	Insulation	DB62-04318S	1	
	Insu DRAIN HOSE	DB62-11028A	1	
	INSU HOSE D	DB62-11028E	1	
	INSU TUBE OUT	DB62-11028F	1	
	ASSY DRAIN HOSE JOINT	DB67-01191A	1	
	Ass'y Drain Hose Joint	DB90-06701A	1	
	GROMMET-HANGER	DB63-00237A	8	
	CARD WARRANTY	DB68-02596B	1	







Accessories (cont.)

■ AC***RNADKG/AC***RNTDKG

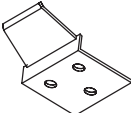
Item	Description	Code No.	Q'ty	Remark
	Remote Control	DB93-15882F	1	Essential Offer (Indoor Unit)
	Batteries for Remote Control	4301-000121	2	
	USER MANUAL INSTALLATION MANUAL	DB68-08134A DB68-08135A	1/1	
	Remote Control Holder	DB61-06087A	1	
	M4 x 16 Tapped Screws	6002-000234	2	
	CARD WARRANTY	DB68-02596B	1	
	Cap Screws	DB67-01404B	3	









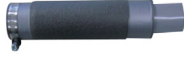

Accessories (cont.)

■ AC***RNCDKG

Item	Description	Code No.	Q'ty	Remark
	USER MANUAL INSTALLATION MANUAL	DB68-08132A DB68-08133A	1/1	Indoor Unit
	PLATE WALL	DB61-01351A	2	
	Remote Control	DB93-16761Z	1	
	Remote Control Holder	DB61-06087A	1	
	Batteries for Remote Control	4301-000121	2	
	M4 x 16 Tapped Screws	6002-000234	2	
	CARD WARRANTY	DB68-02596B	1	

Accessories (cont.)

■ AC***RN4PKG

Item	Description	Code No.	Q'ty	Remark
	ASSY DRAIN- HOSE	DB94-02719B	1	Standard/ Indoor unit
	Cable tie	DB65-00191A	6	
	Seal-drain ass'y	DB62-05810A	1	
	Seal-drain ass'y	DB94-05810F	1	
	Seal-drain ass'y	DB94-05810G	1	
	Indoor unit installation manual	DB68-08157A	1	
	USER MANUAL	DB68-08165A	1	
	CARD WARRANTY	DB68-02596B	1	
	Bolt-flange	6009-001435	4	Standard/Panel
	INSTALL MANUAL	DB68-05903A	1	

Accessories (cont.)

■ AC***RNJDKG

Item	Description	Code No.	Q'ty	Remark
	Remote Control	DB93-16761Z	1	Indoor Unit
	Batteries for Remote Control	4301-000121	2	
	USER MANUAL INSTALLATION MANUAL	DB68-08270A DB68-08271A	1/1	
	Remote Control Holder	DB61-06087A	1	
	M4 x 16 Tapped Screws	6002-000234	2	
	CARD WARRNATY	DB68-02596B	1	
	Insulation install out	B62-05580V	1	
	Insulation install SVC	DB62-05691C	1	
	Cable-tie	6501-001110	8	

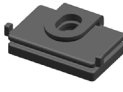
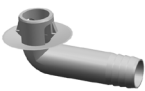
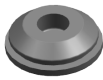

Accessories (cont.)

■ Outdoor Unit: AC***RXAD*G

Item	Description	Code No.	Q'ty			Remark
			AC026RXADKG AC035RXADKG	AC052RXADKG AC071RXADKG	AC100RXAD*G AC120RXAD*G AC140RXAD*G	
	MANUAL INSTALL	DB68-08136A DB68-12187A	1/1	1/1	-	Outdoor Unit
		DB68-08277A DB68-12191C	-	-	1/1	
	RUBBER-LEG	DB67-01533A	4	4	-	
		DB73-20134A	-	-	4	
	DRAIN-PLUG OUT	DB67-20011A	1	1	-	
		DB67-00806A	-	-	1	
	SEAL DRAIN	DB63-10355C	-	5	3	

3. Disassembly and Reassembly

■ Necessary Tools





Item	Remarks
+ SCREW DRIVER	
Adjustable Wrench (8mm, 10mm, 13mm)	
M6, M8 Hex Wrench	

3-1 Indoor unit

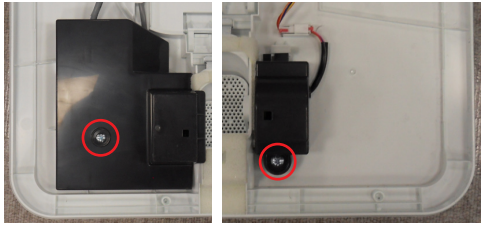
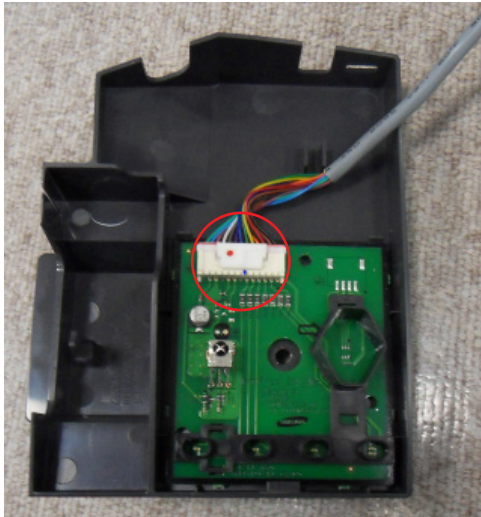
■ AC026RN1DKG/ AC035RN1DKG

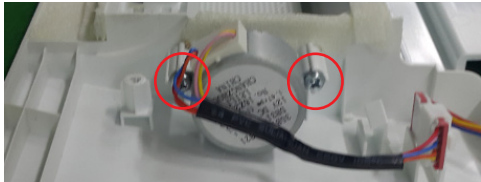

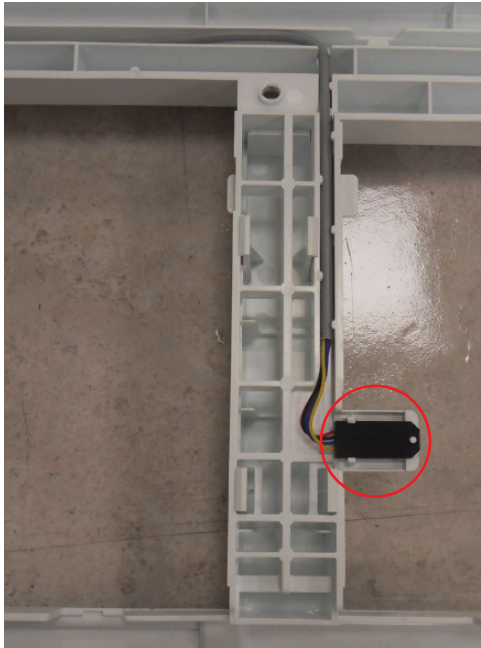
No	Parts	Procedure	Remark
1	PANEL And FILTER WIND FREE TYPE (PC1NWFMAN)	1) Open the GRILLE as shown in the figure. - 3point 2) Remove the FILTER from the PANEL. 3) Remove the 3 COVER SCREW as shown in the figure. 4) Remove the 6 screws fixed in PANEL and then remove the PANEL. (Use +Screw Driver) 5) Press the left and right PANEL HOOK and then separate the PANEL from the indoor unit.	

No	Parts	Procedure	Remark
1	PANEL And FILTER (Continues)	<p>6) Open the GRILLE and then separate the CLIP WIRE.</p> <p>7) Remove the screws fixed in COVER DISPLAY, COVER MOTOR RIGHT and then remove the COVER DISPLAY, COVER MOTOR RIGHT. (Use +Screw Driver)</p> <p>8) Disconnect the connector. (Remote control receiver PBA and Display PBA)</p>	   

No	Parts	Procedure	Remark
1	PANEL And FILTER (Continues)	<p>9) Remove the 4 screws fixed in STEP MOTOR and then remove the MOTOR. (Use +Screw Driver)</p> <p>10) Remove the 4 HINGE and then separate the BLADE H.</p> <p>11) Separate the SENSOR HUMIDITY.</p> <p>12) Remove the 4 screws fixed in GUIDE AIR and then remove the GUIDE AIR. (Use +Screw Driver)</p> <p>13) Separate the PLATE.</p>	     

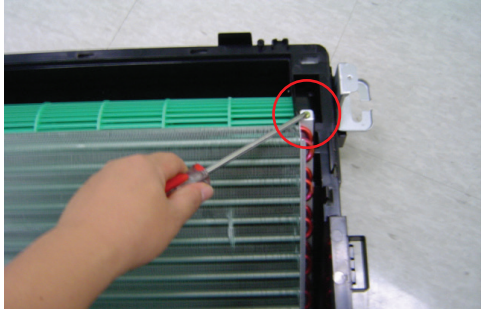
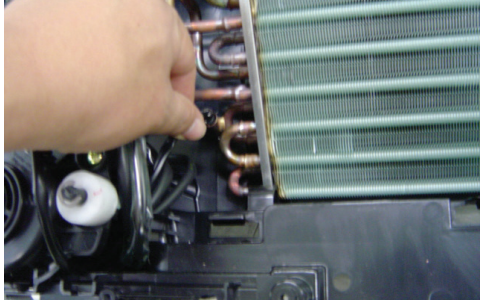
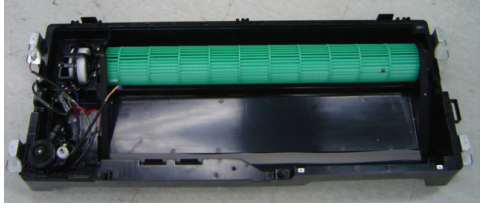
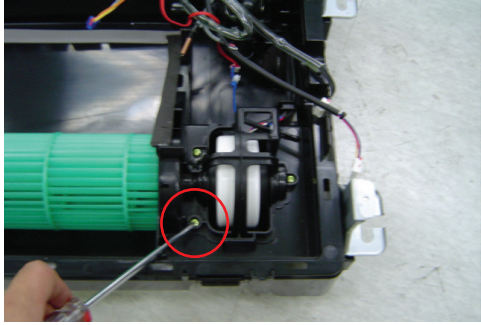
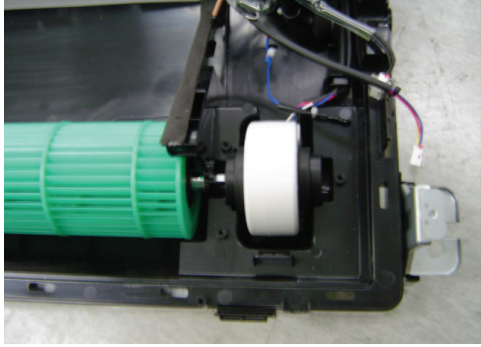
No	Parts	Procedure	Remark
		<p>2) Separate 8 connectors on the PCB of the Indoor Unit.</p> <p>3) Separate the Control In from the Indoor Unit.</p>	
2	Drain Sub	1) Push the hook on the Drain Sub to separate it.	

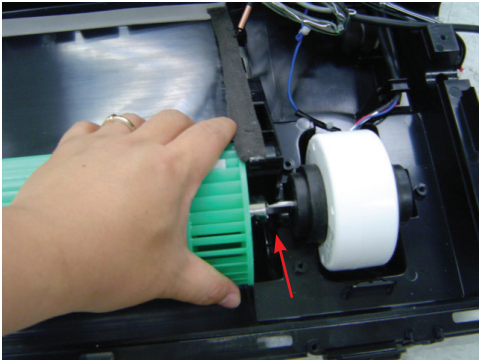
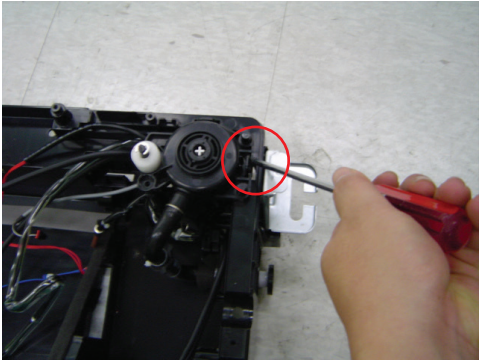
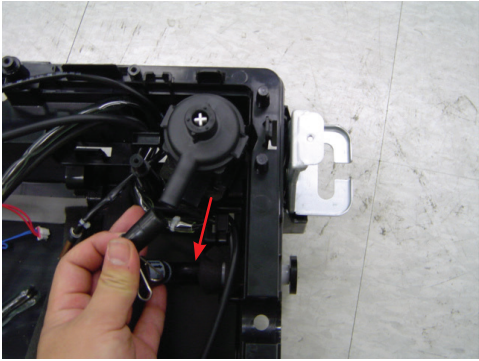
No	Parts	Procedure	Remark
3	Heat Exchanger	1) Undo fixing screw in the Heat Exchanger. (Use +Screw Driver) 2) Separate an Indoor Sensor from the Heat Exchanger. 3) Separate the Heat Exchanger from the Indoor Unit.	  
4	Cross Fan	1) Undo 3 fixing screws on the Cover Fan Motor. (Use +Screw Driver) 2) Separate the Cover Fan Motor from the Indoor Unit.	 



No	Parts	Procedure	Remark
4		3) Separate the Cross Fan from the Indoor Unit.	
5	Drain Pump	<p>1) Separate fixing screw in the Cover Drain Pump. (Use +Screw Driver)</p> <p>2) Separate the Drain Hose from the Drain Pump.</p> <p>3) Separate the Drain Pump from the Indoor Unit.</p>	  



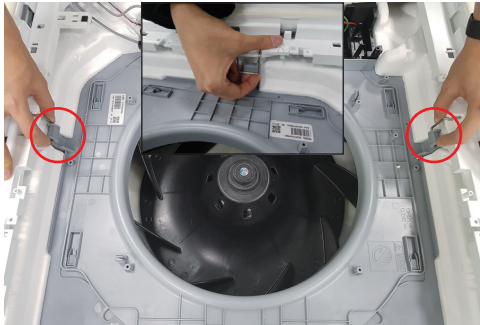
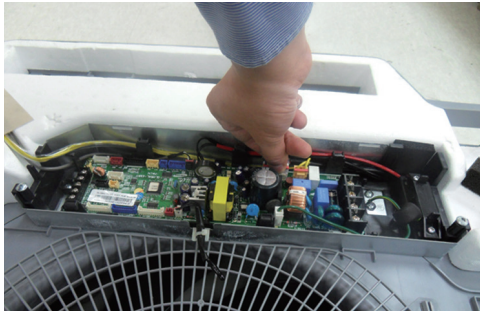
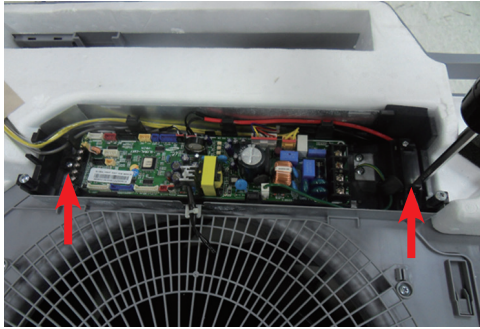
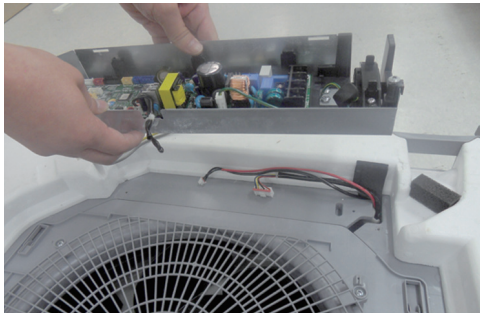

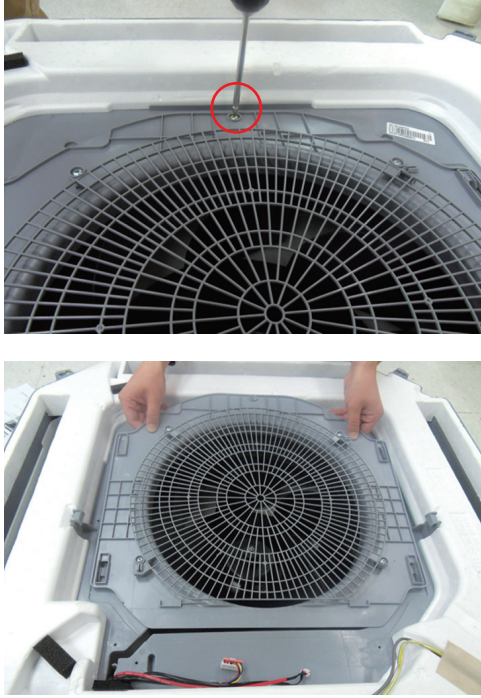
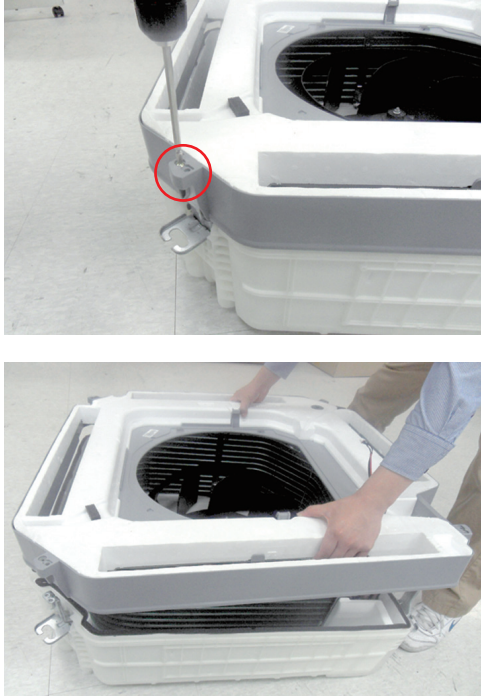
■ AC052RN4DKG/ AC071RN4DKG/ AC100RN4DKG/ AC120RN4DKG/ AC140RN4DKG

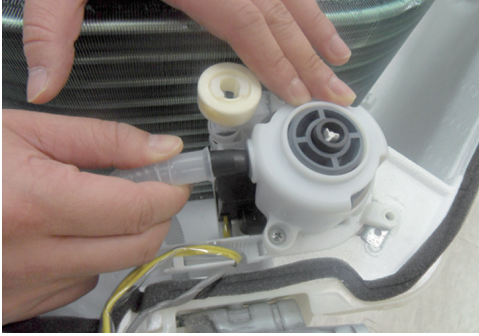
No	Parts	Procedure	Remark
1	Panel	<p>1) Pull two levers below Samsung logo to open the grille.</p> <p>2) Detach the safety clip and white link from the panel.</p> <p>3) Remove the 2 fixed screws to remove the Control-Box Cover. (Use +Screw Driver)</p> <p>4) Remove the 4 connector wires from the PBA. (Remocon-Receiver, Blade motor and Humidity sensor)</p> <p>5) Detach the 4 corners of the panel using both hands..</p>	

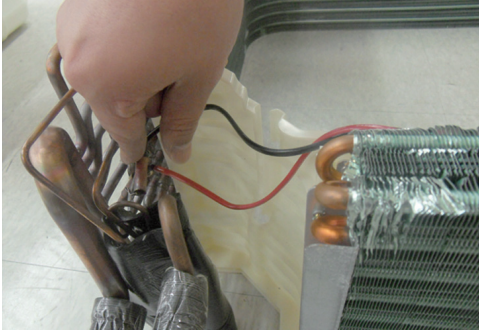
No	Parts	Procedure	Remark
1	Panel	6) Disassemble the bolts that are assembled with the indoor unit at the 4 panel corners.	
		7) Press the Steel Hangers at both sides of the panel inwards, and rotate them 90 degrees to remove it from the indoor unit's Hock. Remove the panel from the indoor unit.	
2	Control-Box	<p>1) Disconnect the Connector Wire that is connected to the indoor unit's PBA from the PBA.</p> <p>2) Unscrew the 2 fixed screws on both sides of the Control Box, and disassemble the Control Box from the indoor unit. (Use +Screw Driver)</p>	  

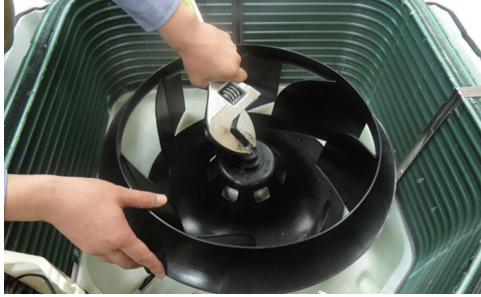
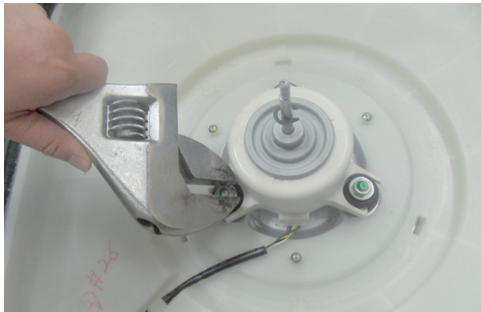
No	Parts	Procedure	Remark
3	Bell-Mouth	<p>1) Unscrew the screw fixed on the Bell-Mouth. (Use +Screw Driver)</p> <p>2) Push the Bell-Mouth in the direction opposite to where it's installed on the Control-Box to remove it.</p>	
4	Drain Pan	<p>1) Unscrew the screws on the 4 corners of the indoor unit. (Use +Screw Driver)</p> <p>2) Remove the Drain Pan from the indoor unit.</p>	

No	Parts	Procedure	Remark
5	Drain Pump & Hose	<p>1) Remove the 2 fixed screws and disconnect the white drainage hose from the Drain Pump. (Use +Screw Driver)</p> <p>2) Remove the 2 screws and take the Drain-Hose out from the indoor unit to disassemble the transparent Drain-Hose fixed on the side of the indoor unit. (Use +Screw Driver)</p>	  
6	Evap. Temperature Sensor	<p>1) Use your hand to remove the temperature sensor attached to the Evap Pipe along with the fixing clip.</p>	



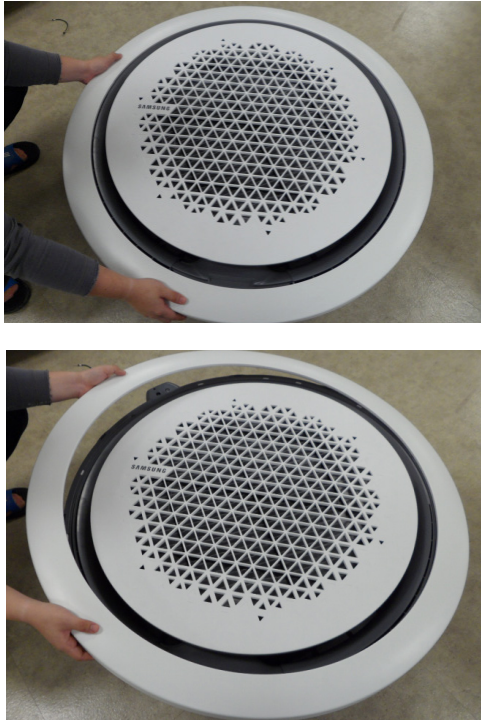

No	Parts	Procedure	Remark
7	Fan & Motor	<p>1) Turn the hexangular nut attached to the top of the Fan counterclockwise to remove it. Take the Fan out of the Motor.</p> <p>2) Turn the three hexangular nuts on the Motor counterclockwise to remove the nuts. Take the Motor Wires attached to these three locations out with your hands prior to removing the Motor.</p>	  
8	Evaporator	<p>1) Remove the screws of the 2 Steel Holder Evaps that are used to fix the Heat Exchanger, and then remove it. (Use +Screw Driver)</p> <p>2) Remove the 2 fixing screws of the Partition Evap at the Heat Exchanger's In/ Out Pipe. (Use +Screw Driver)</p>	 

No	Parts	Procedure	Remark
		<p>3) Remove the screw of the Cover Pipe that is used to fix the In/ Out Pipe. Remove the In/ Out Pipe. (Use +Screw Driver)</p> <p>4) Remove the Heat Exchanger from the indoor unit's cabinet.</p>	  

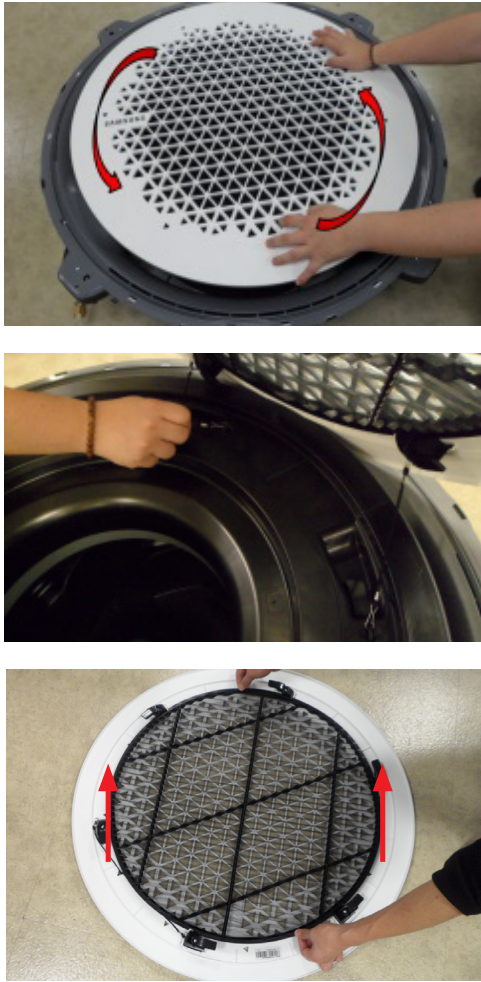
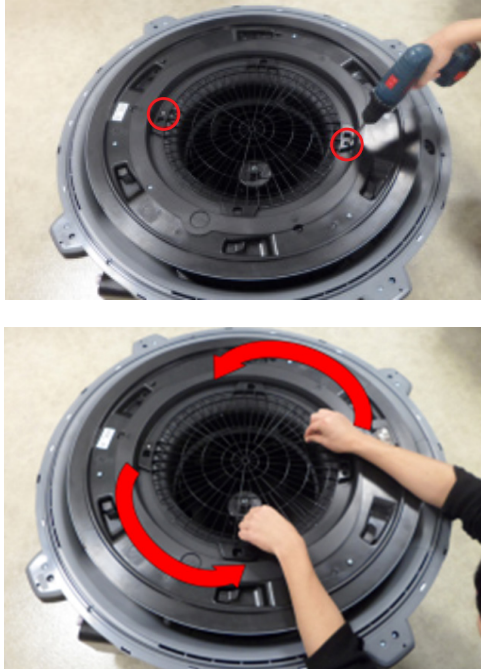

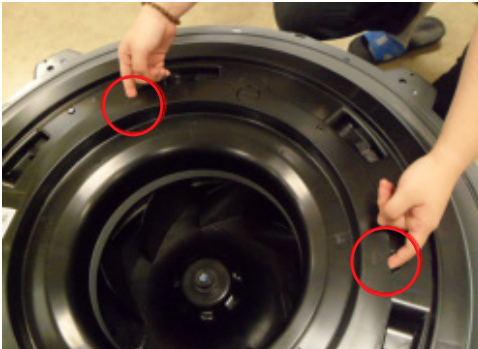
■ AC071RN4PKG/ AC100RN4PKG/ AC120RN4PKG/ AC140RN4PKG

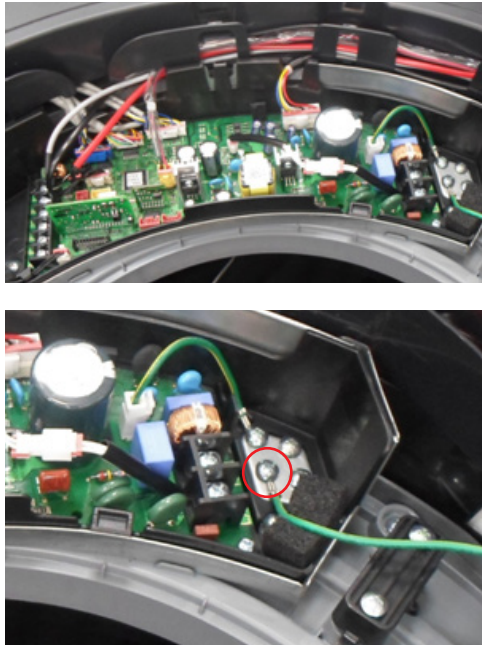
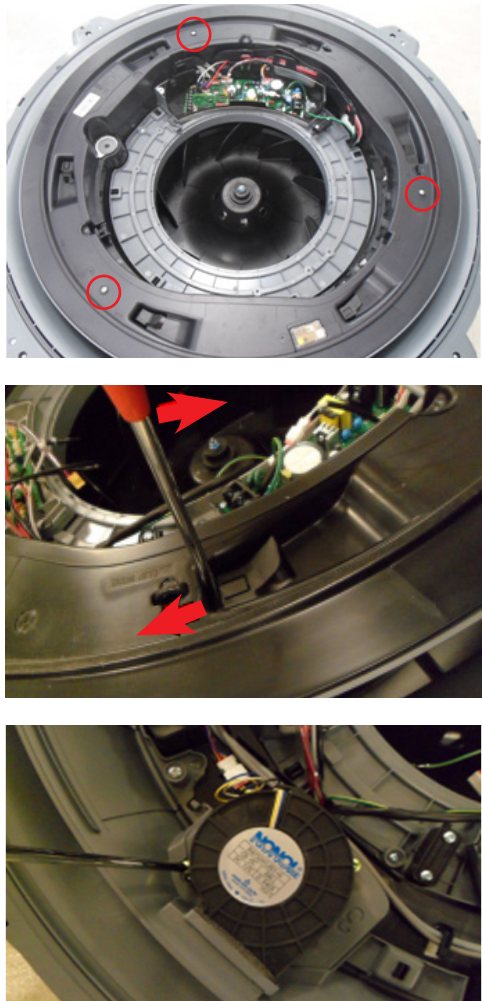

No.	Parts	Procedure	Remark
1	Panel	<p>▶ Ceiling type Panel</p> <p>1) Pull up the corner 4 places of Panel and separate it.</p> <p>2) Remove 4ea of screws from the corner of Panel. (Use +Screw Driver)</p> <p>3) Pull the hook of Panel and then separate the Panel from the Indoor Unit.</p>	
1	Panel	<p>▶ Open type Panel</p> <p>1) Rotate the outside Panel to counterclockwise direction and then separate it.</p>	

No.	Parts	Procedure	Remark
1	Panel	<p>2) Rotate the Grille to counterclockwise direction.</p> <p>3) Remove the safety clip of Grill inside and then separate the Panel from the Indoor Unit.</p> <p>4) Pull up the Filter from the Grill and separate it.</p>	
2	Control Box	<p>1) Remove 2ea of screws which is fixed to the Indoor Unit upper part. (Use +Screw Driver)</p> <p>2) Rotate the Guard Fan to counterclockwise direction and separate it</p>	

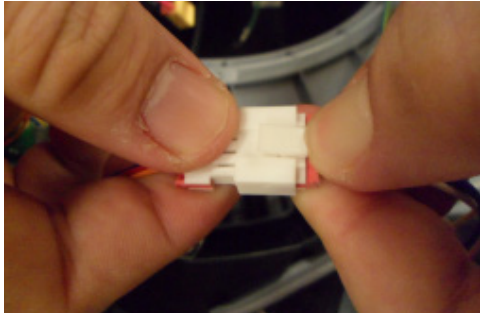
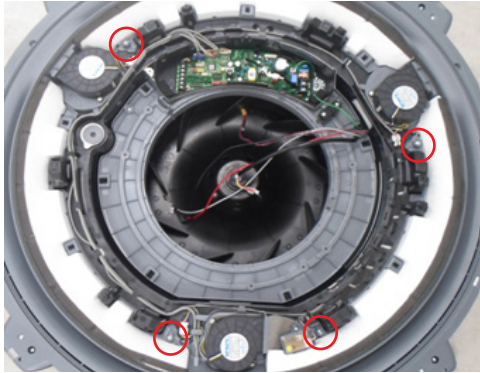
No.	Parts	Procedure	Remark
2	Control Box	<p>3) Remove a screw which is fixed to the Indoor Unit upper part. (Use +Screw Driver)</p> <p>4) Put finger in the "PULL" marked groove and then pull up the Cover</p> <p>5) Put finger in the "PULL" marked groove and then avoids the hook and it opens the Control Box Cover</p>	    



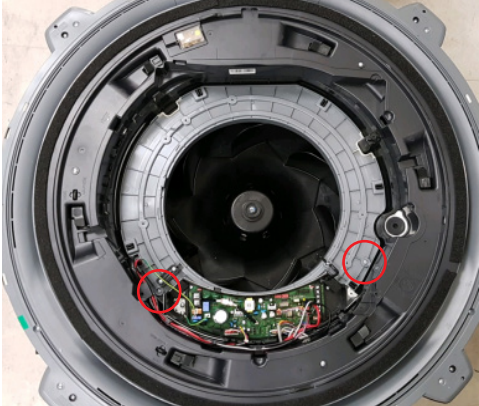

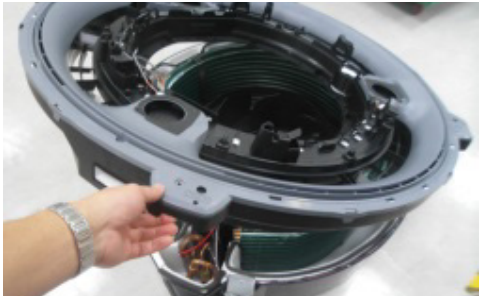
No.	Parts	Procedure	Remark
2	Control Box	6) Separate the connectors from the Control Box. 7) Remove the ground screw. (Use +Screw Driver)	
3	Top Cover & Drain Pan	1) Remove the 3ea of screws. (Use +Screw Driver) 2) Push the hook and separate the Cover. ⚠ Damage can occur to product in case of use a sharp tool. 3) Remove the screw which is fixed to Booster Fan. (Use +Screw Driver)	

No.	Parts	Procedure	Remark
3	Top Cover & Drain Pan	<p>4) Pull the Booster Fan connector and separate the connector.</p> <p>5) Remove the 4ea of screws (Use +Screw Driver)</p> <p>6) Push the hook and separate the Cover.</p>	    

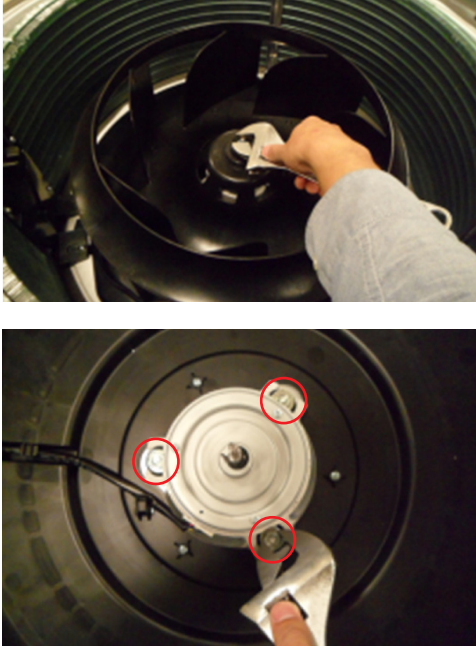
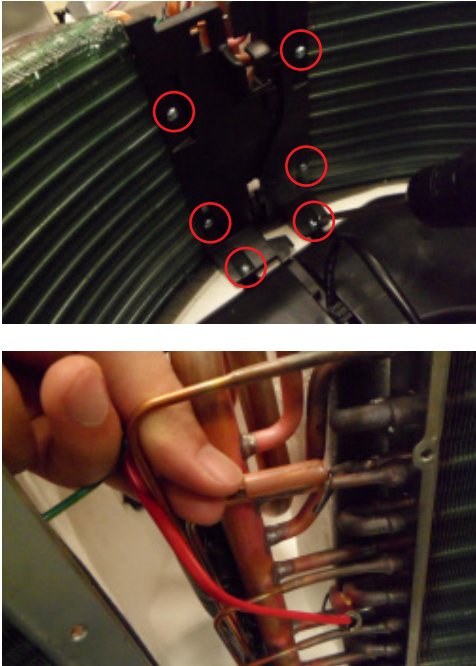
No.	Parts	Procedure	Remark
3	Top Cover & Drain Pan	<p>7) Remove the screw and separate the Display Cover. (Use +Screw Driver)</p> <p>8) Remove the 2ea of screws. (Use +Screw Driver)</p> <p>9) Push the hook and separate the Cover.</p> <p>10) Remove 8ea of screws. (Use +Screw Driver)</p> <p>11) Separate the Indoor Unit upper part from the Body.</p>	    

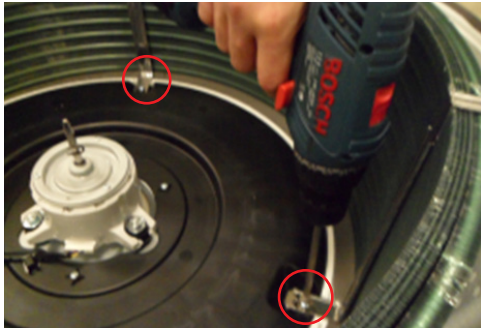
No.	Parts	Procedure	Remark
3	Top Cover & Drain Pan	<p>12) Remove the 3ea of screws. (Use +Screw Driver)</p> <p>13) Pull the hook that is on the side and separate the Cover.</p>	   
4	Drain Pump & Hose	1) Separate the Drain Hose from the Drain Pump.	

No.	Parts	Procedure	Remark
4	Drain Pump & Hose	2) Remove 2ea of screws and separate the Drain Hose that is on the side lower part of Indoor Unit. (Use +Screw Driver)	
5	Fan & Motor	1) Remove the hex nut which is fixed to top of Fan and separate the Fan from the Motor. (Use Monkey Spanner) 2) Remove the 3 hex nuts which is fixed to Motor and separate the Motor from the Indoor Unit. (Use Monkey Spanner)	
6	Temperature Sensor	1) Remove 6ea of screws which are fixed to Evaporator and separate the Partition. 2) Separates the Temperature Sensor which is fixed to Evaporator Pipe with the fixing clip together by the hand.	

No.	Parts	Procedure	Remark
7	Evaporator	<p>1) Remove 2ea of screws which are fixed to Indoor Unit and separate the Evaporator fixing bracket. (Use +Screw Driver)</p> <p>2) Remove a screw which is fixed to Indoor Unit and pull the hook and then separate the Drain Cover. (Use +Screw Driver)</p> <p>⚠ When assemble, be careful with the interference structure of piping projecting p</p> <p>3) Separate the Evaporator from the Indoor Unit.</p> <p>⚠ If you remove the Evaporator with bare hands, it may injure your hands, gloves must be worn.</p>	    

■ AC100RNCDKG/ AC120RNCDKG/ AC140RNCDKG

No	Parts	Procedure	Remark
1	Electrial Part	<p>⚠ You must turn off the Power before disassembly.</p> <p>1) Open the Grille by sliding 4 position and removing 4 screws.</p> <p>2) Detach the Air Inlet Grille.</p> <p>3) Detach the Cover side by removing 1 screw and sliding Cover.</p> <p>4) Open the cover of Component Electrical Box by removing 2 screws.</p> <p>5) Open the cover of Terminal block Box by removing 2 screws</p>	

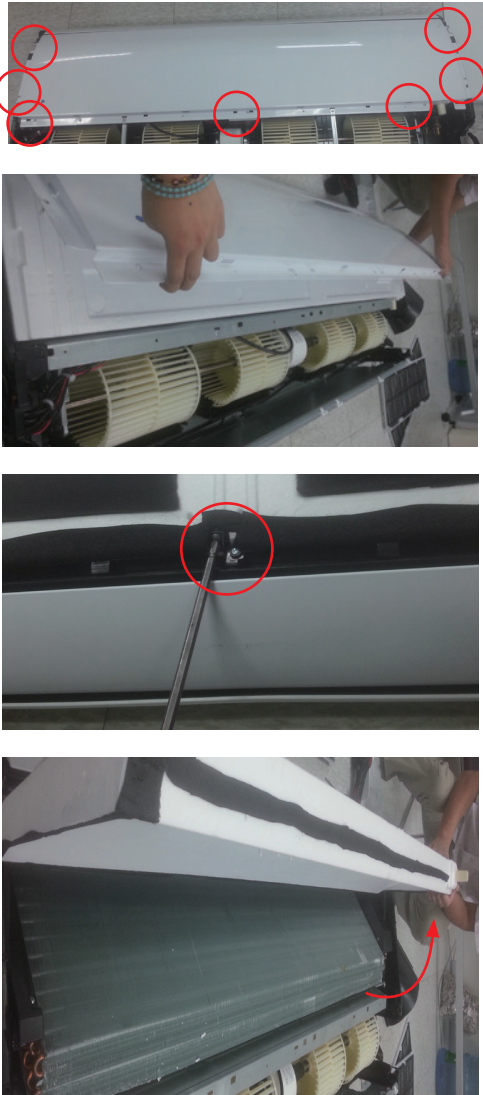

No	Parts	Procedure	Remark
2	Fan & Motor	<p>1) Disconnect 2 wires of Motor.</p> <p>2) Detach Holder Motor by removing 2 screws.</p> <p>3) Detach the Upper case of Fan. (4EA)</p> <p>4) Detach Bracket Grille by removing 2 Screws.</p>	

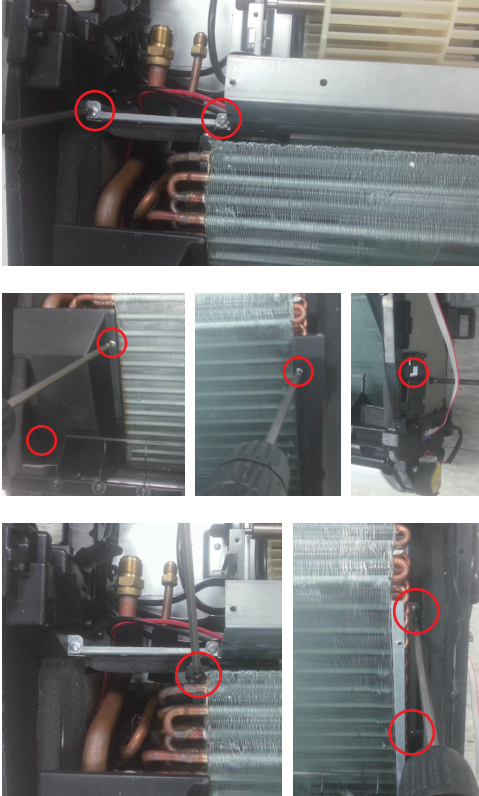
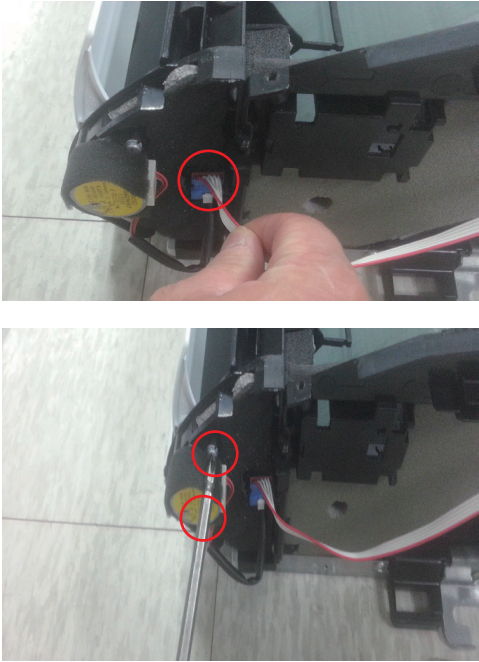
No	Parts	Procedure	Remark
3	Drain Pan	<p>1) Detach the Cabinet Front by removing 7 screws.</p> <p>2) Remove 1 screw in the middle of drain pan.</p> <p>3) Detach the Drian pan. Be careful that there might be some water left in the drain pan when you remove the drain pan.</p>	

No	Parts	Procedure	Remark
4	Evaporator	<p>1) Detache the Cover Pipe by removing 2 screws.</p> <p>2) Detache the Cover Evap LF/ RH by removing 4 screws.</p> <p>3) Detach the Evaporator assembly by removing 3 screws.</p>	
5	Stepping Motor	<p>1) Detach the Connector.</p> <p>2) Detache the Stepping Motor by emoving 2 screws.</p>	

No	Parts	Procedure	Remark
6	Holder Blade	1) Remove 4 screws at both side of the Holder blade.	



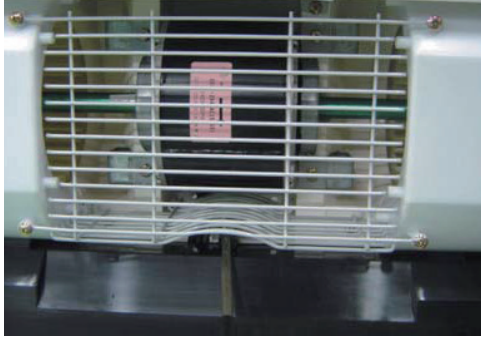

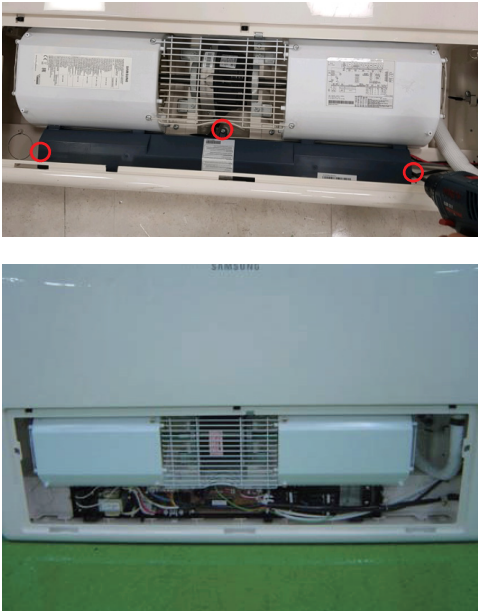
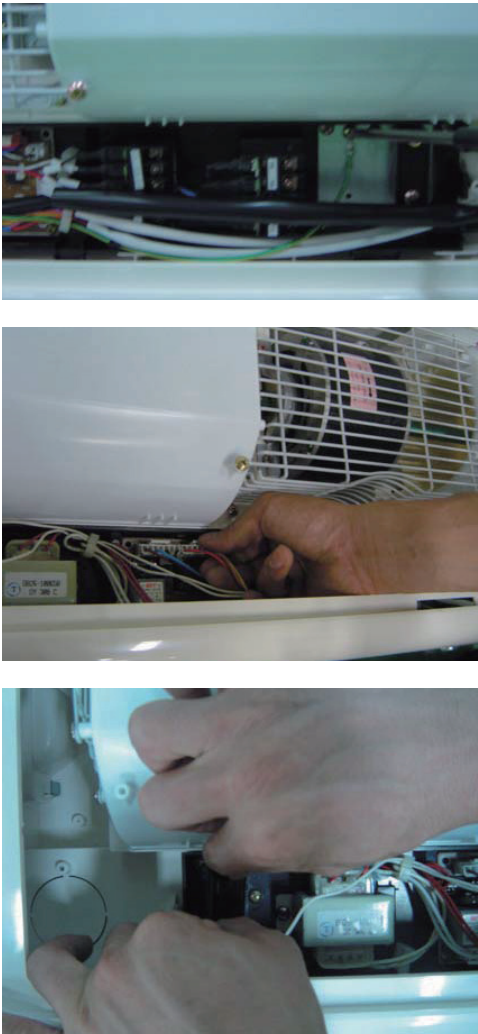
■ AC052RNCDKG/ AC071RNCDKG

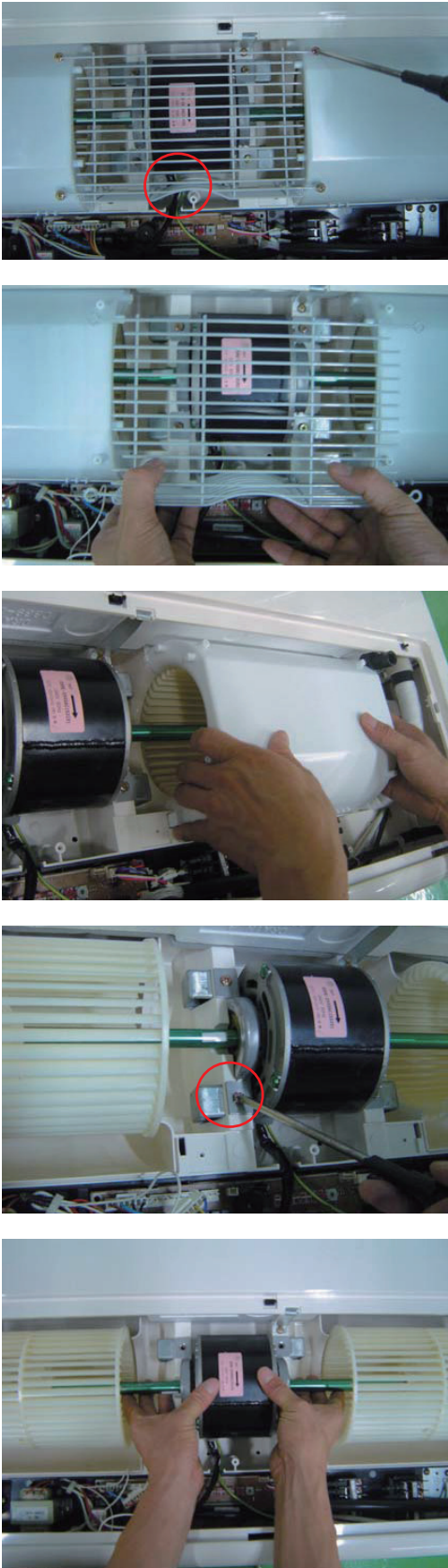

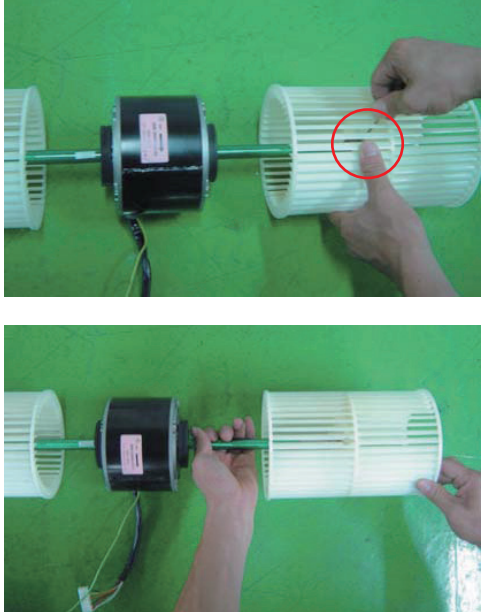
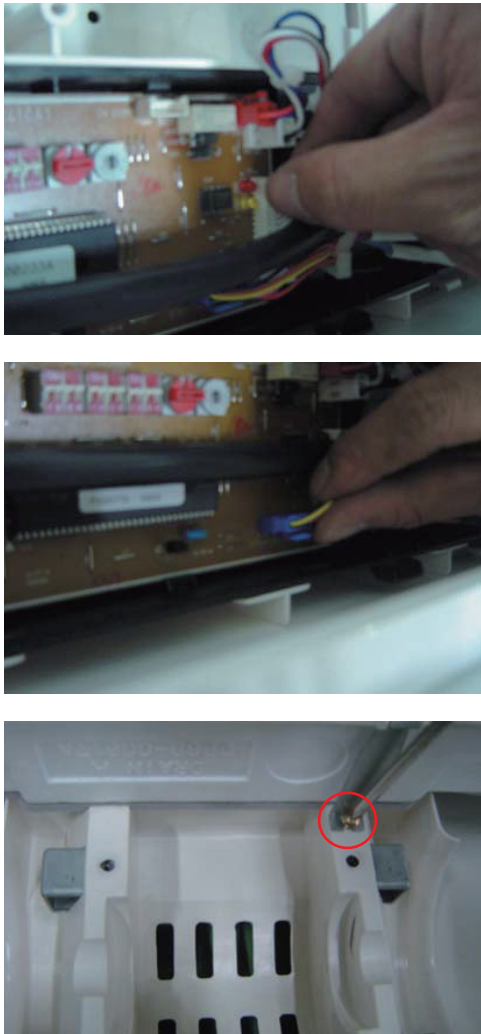
No	Parts	Procedure	Remark
1	PANEL And FILTER WIND FREE TYPE (PC1NWFMAN)	1) Open the Grille by pressing 3 position. (center and both side) 2) Detach the Air Inlet Grille. 3) Open the Cover of component Electrical Box removing 3 screws. (center and both side)	   



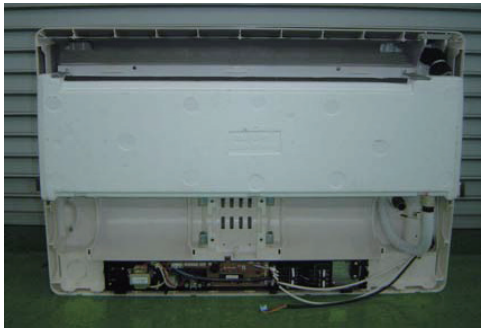

No.	Parts	Procedure	Remark
			
2	Fan & Motor	<p>1) Detach the screw and untie earth wire of Motor.</p> <p>2) Disconnect of housing of Motor Wire.</p> <p>3) Disconnect the Capacity Wire.</p>	

No.	Parts	Procedure	Remark
		<p>4) Loosen the Guard Safety by removing 6 screws.</p> <p>5) Detach the Upper Case of Fan. (2EA)</p> <p>6) Loosen the 4 screws what is fix the Motor.</p> <p>7) Detach the Fan and Motor assembly.</p>	



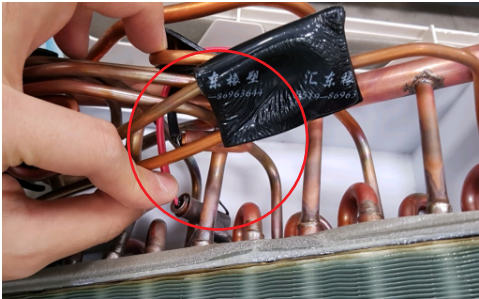

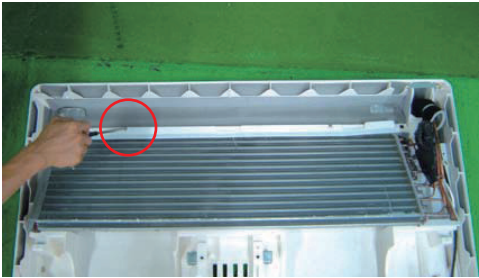
No.	Parts	Procedure	Remark
		<p>8) Loosen the set fixing bolts. (with a M3 wrench)</p> <p>9) Detach the Fan.</p>	
3	Drain Pan	<p>1) Disconnect the Display PCB Wire as shown in picture. (White housing)</p> <p>2) Disconnect the Step Motor Wire as shown in picture. (blue housing)</p> <p>3) Dosassemble the Hanger Bracket by removing the 1 screw.</p>	









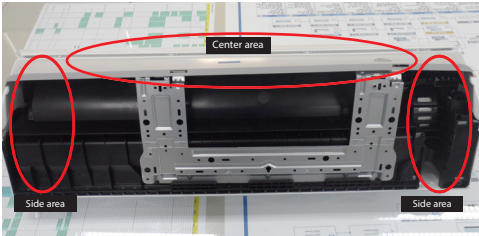

No.	Parts	Procedure	Remark
		<p>4) Loosen the 3 screws of Front Side.</p> <p>5) Disassemble the assembly Front Cover Part.</p> <p>6) Disconnect the Step Motor Wire as shown in picture.</p> <p>7) Detach Wire Clamp fixed in Base Part.</p> <p>8) Detach the Front Cover assembly completely.</p>	    

No.	Parts	Procedure	Remark
		<p>9) Loosen the screw what is fix with Base Part and Drain Pan. (Upper Sied:2EA)</p> <p>10) Loosen the screw what is fix with Base Part and Drain Pan. (Lower Side:2EA)</p> <p>11) Detach the Drain Pan completely.</p>	  

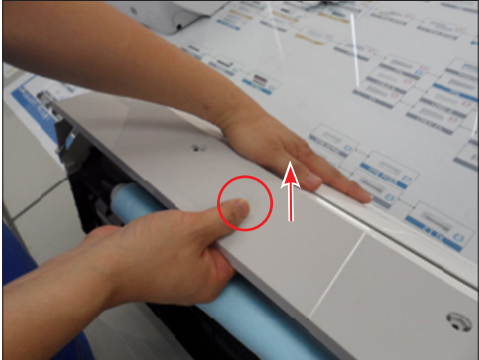
No.	Parts	Procedure	Remark
4	Evaporator	<p>1) Disconnect the Thermistor Wire as shown in picture. (white housing)</p> <p>2) Loosen the 2 screws shown in picture.</p> <p>3) Loosen the 2 screw shown in picture and and remove Plastic Part. (white)</p> <p>4) Loosen the 2 screw shown in picture and remove Steel Bracket.</p> <p>5) Disassemble the 4 screws Steel Plate in rear side of the unit.</p>	    

■ AC026RNADKG/ AC035RNADKG/ AC052RNADKG/ AC071RNADKG

No	Parts	Procedure	Remark
1	Panel-Front	<p>1) Stop the driving of air conditioner and shut off main power supply.</p> <p>2) Detach FILTER PRE from the PANEL FRONT.</p> <p>3) Cover Panel is assembled on bottom of indoor unit as shown in the figure. Remove the Cap Screw as shown on the right side and then remove the screw and separate the Cover Panel.</p>	   

No	Parts	Procedure	Remark						
		<p>4) Cover Panel is fixed to body by Hook in center area and side area.</p> <p>5) Separate the hook after pushing both end of Cover Panel as shown in the figure. (Watch out for the damage of the hook)</p> <p>6) Raise front part upward obliquely as shown in the figure and then remove the hooks.</p>	 <table border="1" data-bbox="930 622 1410 779"> <thead> <tr> <th colspan="2">HOOK</th> </tr> </thead> <tbody> <tr> <td>026/ 035</td> <td></td> </tr> <tr> <td>052/ 071</td> <td></td> </tr> </tbody> </table>   	HOOK		026/ 035		052/ 071	
HOOK									
026/ 035									
052/ 071									

No	Parts	Procedure	Remark
		<p>⚠ Assembly of Cover Panel after service end.</p> <ul style="list-style-type: none"> - Reassembly is in the reverse order of the removal. - Piping and drain hose must be careful not to damage and Progress must be done with both hands. 	

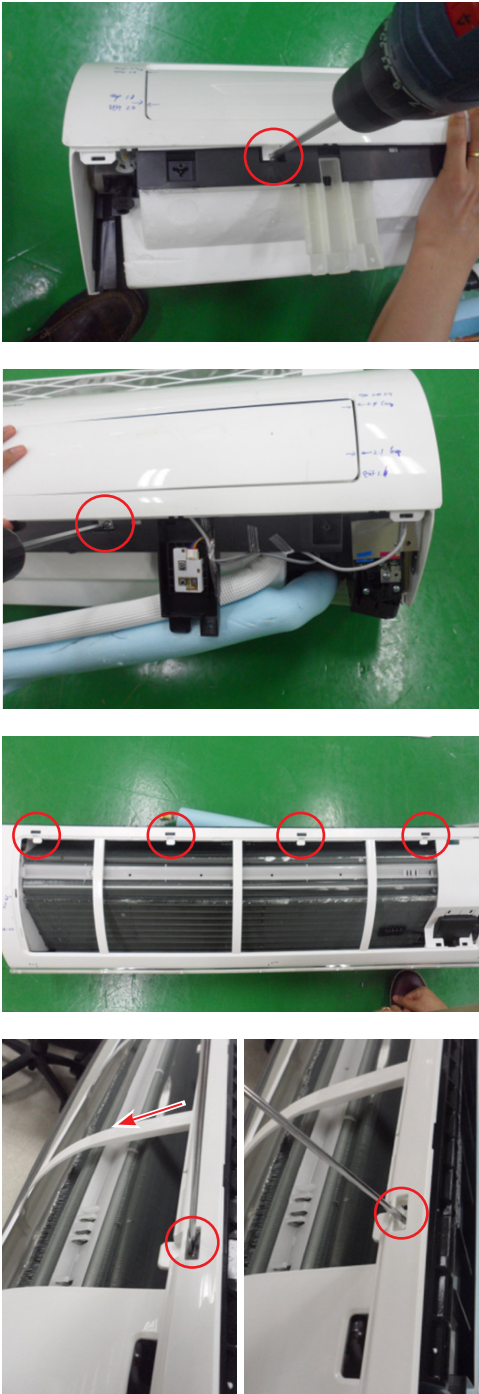
No	Parts	Procedure	Remark
		<p>7) To detach the PANEL-FRONT from the main frame, unfasten 2 screws at the bottom. (use + Screw Driver)</p> <p>8) To detach the COVER-PANEL from the main frame, loosen 4 HOOK Structures. When separate the hook: Use the (-) screw Driver. (-)Screw Driver Insert the hook and then pull the hook as shown on the right side. (Watch out for the damage of the hook)</p>	

No	Parts	Procedure	Remark
		<p>9) Remove the Panel Frame from the Main Frame as shown on the right side.</p>	

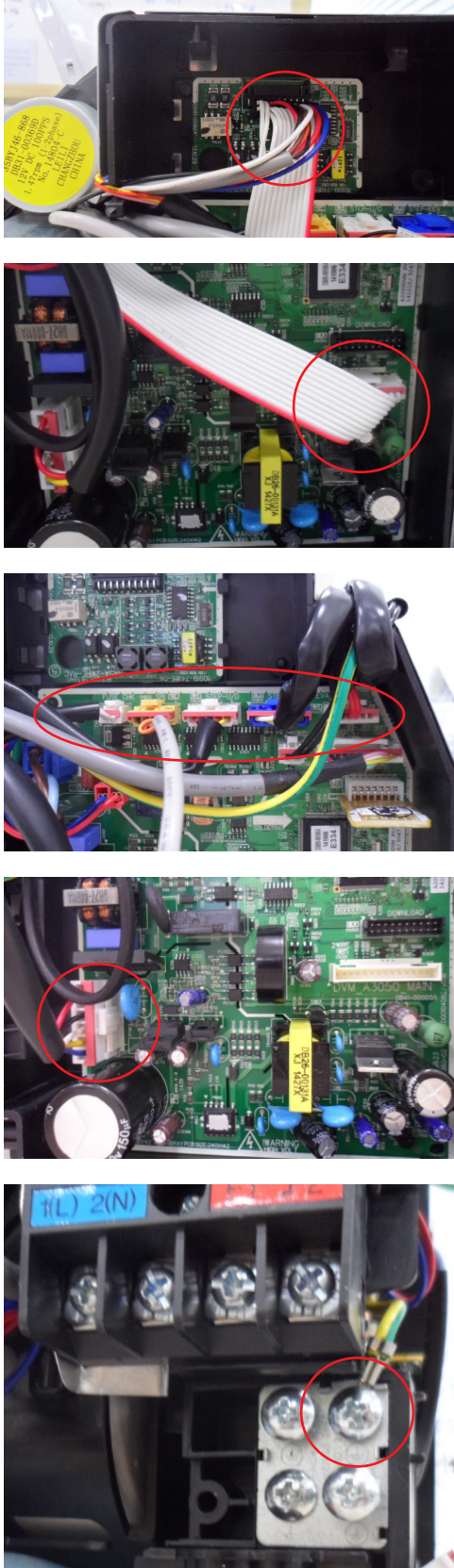
No	Parts	Procedure	Remark
2	Control In	<p>1) Disconnect Sub PBA Wire.</p> <p>⚠ When you separate the connector, pull pressing the locking button.</p> <p>2) Disconnect Stepping Motor, EEV, Display, Sensor, SPI, Fuse Wire.</p> <p>⚠ When you separate the connector, pull pressing the locking button.</p> <p>3) Disconnect Motor, Terminal Wire.</p> <p>⚠ When you separate the connector, pull pressing the locking button.</p> <p>4) Loosen Earth Wire.</p>	

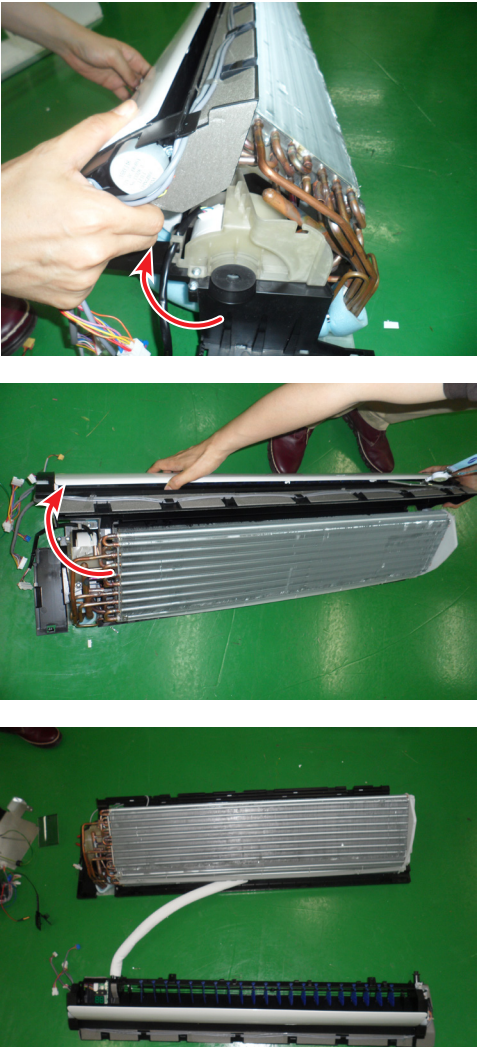
No	Parts	Procedure	Remark
3	Tray Drain	1) To detach TRAY-DRAIN from the main frame, pull the bottom of the TRAY-DRAIN towards you.	

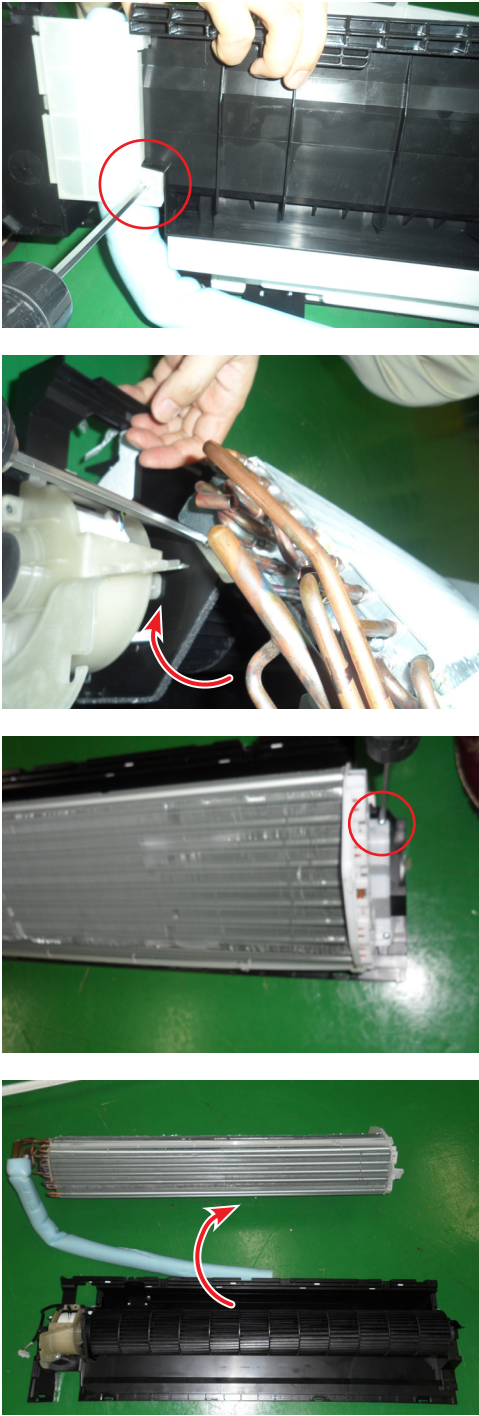
No	Parts	Procedure	Remark
4	Evaporator	<p>1) Detach the HOLDER PIPE.</p> <p>2) Unfasten the screw at the left side. (use + Screw Driver)</p> <p>3) Unfasten the screw at the right side. (use + Screw Driver)</p> <p>4) To detach Evaporator from the main frame, pull the bottom of the Evaporator towards you.</p>	

No	Parts	Procedure	Remark
5	Fan motor & Cross fan	<p>1) Unfasten the screw. (use + Screw Driver)</p> <p>2) Detach the FAN Motor case.</p> <p>3) Unfasten the screw a little. (use + Screw Driver)</p> <p>4) Pull the CROSS-FAN to the left side.</p>	   

■ AC100RNTDKG/ EU

No	Parts	Procedure	Remark
1	Panel-Front	<p>1) Stop the driving of air conditioner and shut off main power supply.</p> <p>2) Open the FRONT-GRILLE and pull out from the PANEL-FRONT.</p> <p>3) Detach COVER-TERMINAL from the PANEL FRONT. (use + Screw Driver)</p> <p>4) Loosen connector wire(white) and detach the temperature sensor wire.</p> <p>5) To detach the FRONT-PANELthe main frame, unfasten 2 screw at the bottom. (use + Screw Driver)</p> <p>6) Take off the FRONT-PANEL, lifting up the bottom</p>	

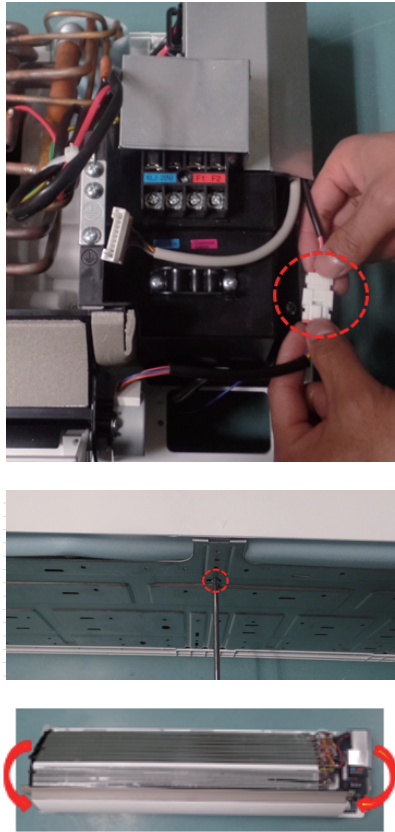
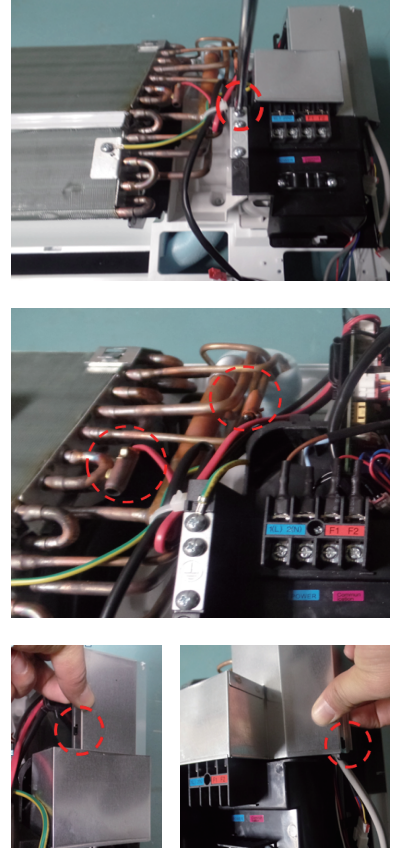
No	Parts	Procedure	Remark
2	TRAY DRAIN	<p>1) Loosen stepping motor wire and detach the hook of main frame.</p> <p>2) To detach TRAY-DRAIN from the main frame, pull the bottom of the TRAY-DRAIN towards you.</p> <p>3) To detach TRAY-DRAIN from the main frame, pull the bottom of the TRAY-DRAIN towards you.</p>	
3	CONTROL IN	<p>1) Unfasten the earth screw. (use + ScrewDriver)</p> <p>2) Detach the temperature sensor and Humidity sensor.</p> <p>3) Detach the temperature sensor.</p>	

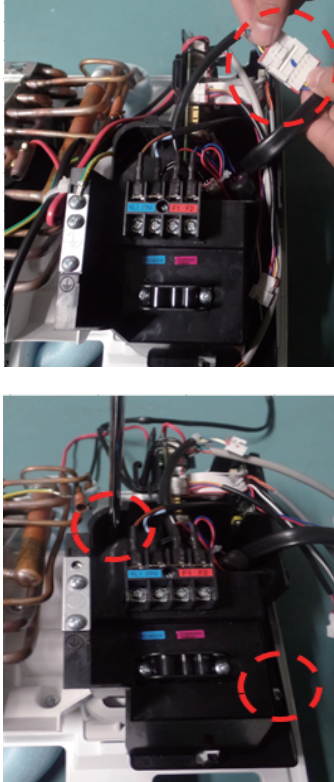
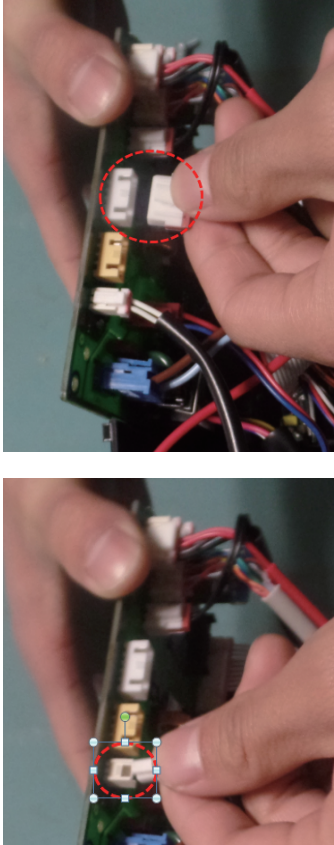
No	Parts	Procedure	Remark
		<p>4) Loosen MOTOR wires (white).</p> <p>5) Take off the CASE-CONTROL from the main frame. (use + Screw Driver)</p>	
4	PBA	<p>1) Loosen the STEP UP/ DOWN connector (CN802).</p> <p>⚠ Caution When you separate the connector, pull pressing the locking button.</p> <p>2) Loosen the FUSE CHK connector (CN140).</p> <p>⚠ Caution When you separate the connector, pull pressing the locking button.</p>	

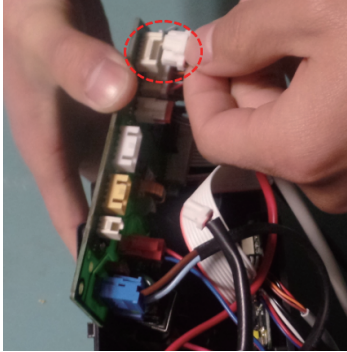
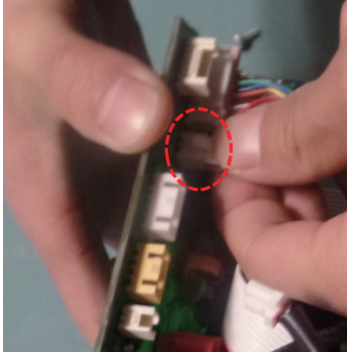
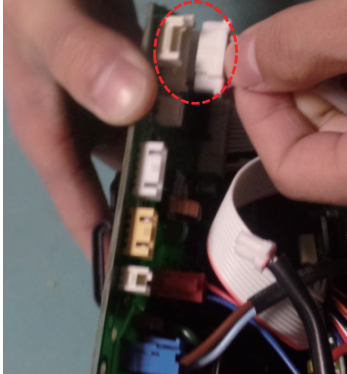
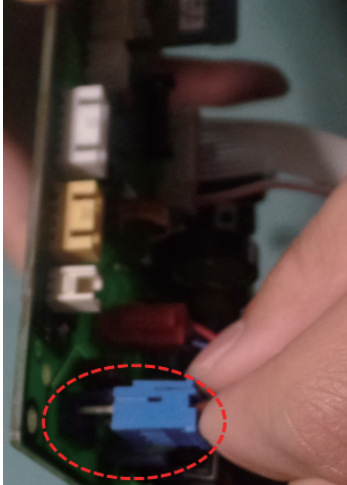
No	Parts	Procedure	Remark
		<p>3) Loosen the EVA IN/ OUT connector. (CN403)</p> <p>⚠ Caution When you separate the connector, pull pressing the locking button.</p>	
		<p>4) Loosen the Humidity sensor connector (CN401). → Option connector.</p> <p>⚠ Caution The terminal is locking type. So, when you separate terminals, pull pressing the button.</p>	
		<p>5) Loosen the DISPLAY connector. (CN501).</p> <p>⚠ Caution The terminal is locking type. So, when you separate terminals, pull pressing the button.</p>	
		<p>6) Loosen the POWER connector.</p> <p>⚠ Caution When you separate the connector, pull pressing the locking button.</p>	

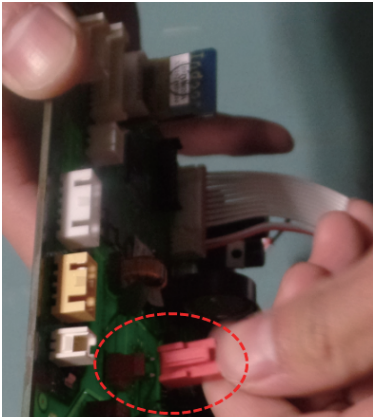
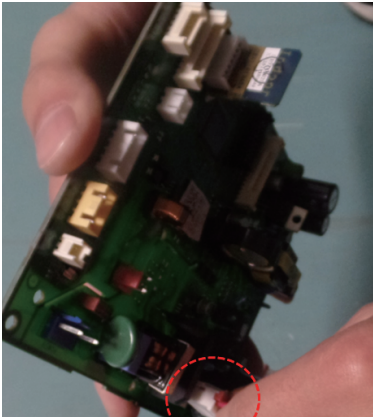
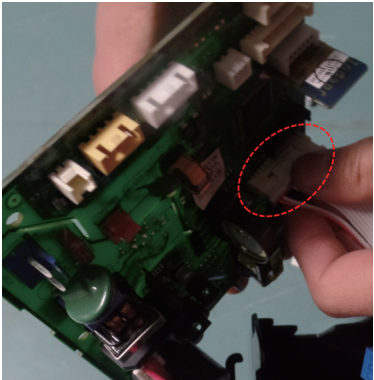
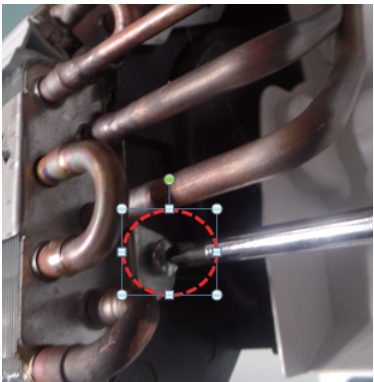

No	Parts	Procedure	Remark
		<p>7) Loosen the COMM wire connector (CN303).</p> <p>⚠ Caution When you take off the PBA, don't touch the components. Please hold the PBA both side.</p> <p>8) Loosen the Motor connector (CN701).</p> <p>⚠ Caution When you separate the connector, pull pressing the locking button.</p> <p>9) Take off the main PBA from the ASS'Y Control in.</p> <p>⚠ Caution When you take off the PBA, don't touch the components. Please hold the PBA both side.</p>	  
5	EVAPORATOR	<p>1) Unfasten the screw at the right side. (use + ScrewDriver)</p>	

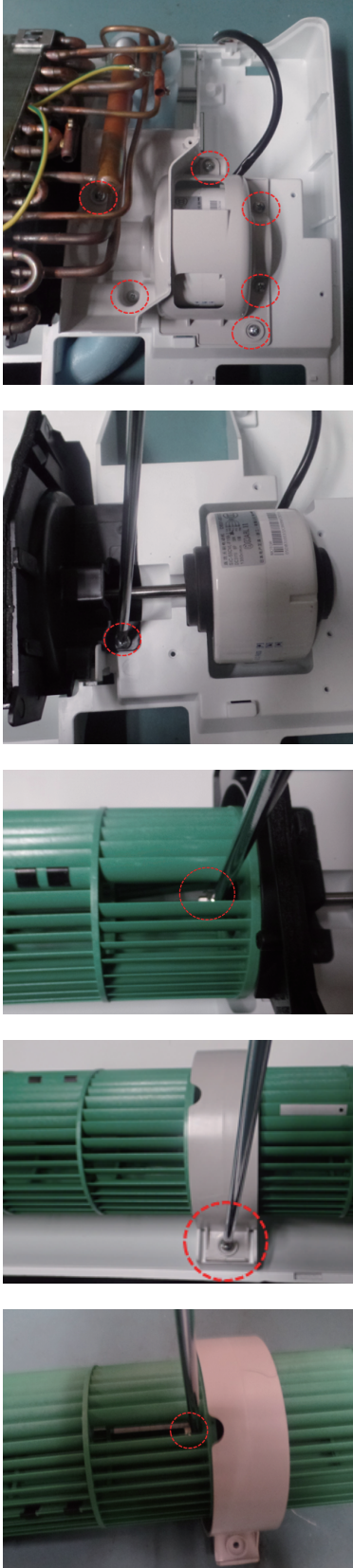
No	Parts	Procedure	Remark
		<p>2) Unfasten the screw at the left side. (use + ScrewDriver)</p> <p>3) Detach the HOLDER PIPE. (use + Screw Driver)</p> <p>4) Detach the BRACKET-EVAP. (use + Screw Driver)</p> <p>5) Detach the HOLDER EVAP. (use + Screw Driver)</p> <p>6) Loosen 1 fixing earth screw right side. (use + Screw Driver)</p>	    

No	Parts	Procedure	Remark
6	FAN MOTOR & CROSS FAN	<p>1) Loosen 6 fixing screws of HOLDER-MOTOR</p> <p>2) unfasten the screw a little. (use + Screw Driver)</p> <p>3) unfasten the screw a little and pull the MOTOR FAN to the right side. (use + Screw Driver)</p> <p>4) Loosen 1 fixing screws of HOLDER-FAN. (use + Screw Driver)</p> <p>5) unfasten the screw a little. (use + Screw Driver)</p>	

■ AC026RNLDKG/ AC035RNLDKG

No	Parts	Procedure	Remark
1	Motor & Blower	<p>1) Disassemble the Cabinet Top Motor. - Unscrew 8 screws</p> <p>2) Disassemble the Cover Blower Upper with pushing its hook.</p> <p>3) Disassemble the Cover Control. - Unscrew 2 screws</p>	 <p>The 'Remark' column contains three photographs illustrating the disassembly steps. The first photo shows the top of the cabinet with 8 screws circled in red. The second photo shows the blower upper cover being pushed down by a hand. The third photo shows the cover control panel with 2 screws circled in red.</p>

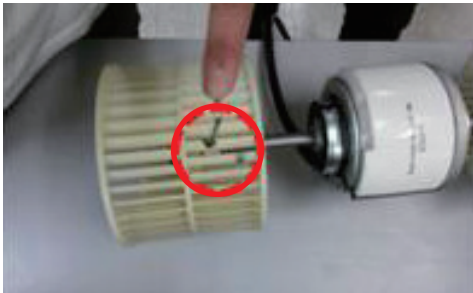
No	Parts	Procedure	Remark
		<p>4) Disassemble Motor Wires connected to the inside of PCB and connected to the Capacitor.</p> <p>5) Disassemble the Motor wire with pushing the clip.</p> <p>6) Disassemble the band Motor for fixing the Motor. - Unscrew 2 screws</p> <p>7) After disassembling the Motor and Blower for the set, disassemble the Blower by use of 3mm wrench.</p>	   

No	Parts	Procedure	Remark
2	Drain Pan	<p>1) Disassemble the Cabinet Top Evap. - Unscrew 11 screws</p> <p>2) Disassemble the Bracket Outlet Sub that fixes the Drain Pan equipped on the front of the set. - Unscrew 6 screws</p> <p>3) Disassemble the Drain Cushion from the set.</p>	  

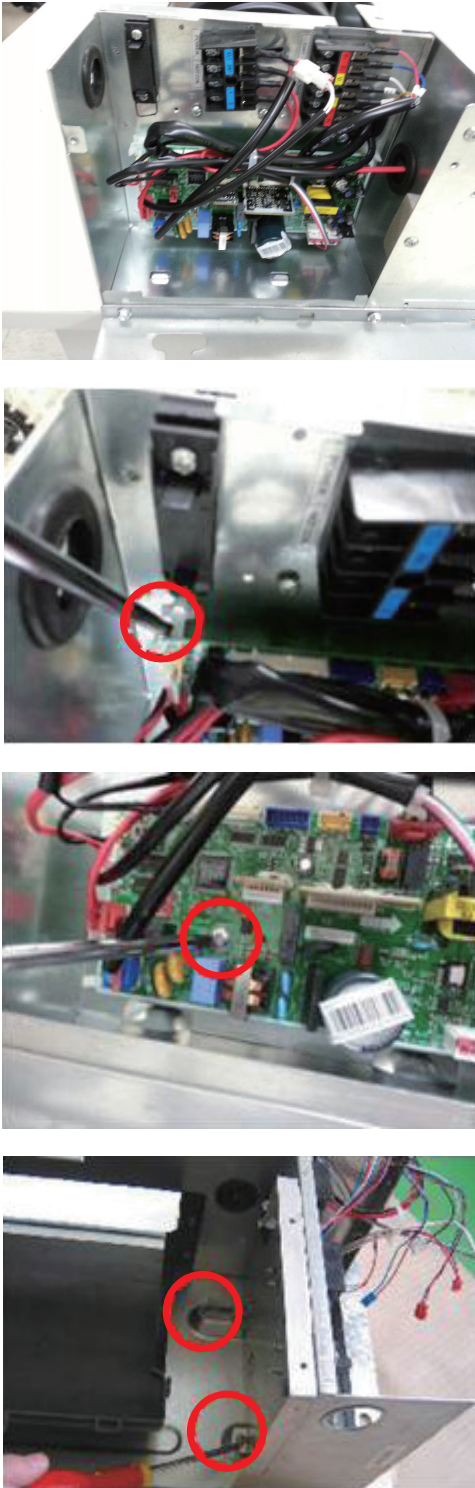

No	Parts	Procedure	Remark
3	Evaporator	<p>► The Evaporator should be disassembled after disassembling the Cover Control 1-3) and the Drain Pan 2-1), 2-2), 2-3).</p> <p>1) Disassemble the Cover Pipe that fixes the high/ low pressure Pipe. - Unscrew 2 screws</p> <p>2) Disassemble the refrigerant temperature sensor, Inlet air temperature sensor, and EEV wire that connected to the inside of PCB.</p> <p>3) Disassemble the Support Evap. LF that fixes the Evaporator. - Unscrew 2 screws</p> <p>4) Disassemble the Support Evap RH. - Unscrew 2 screws</p>	

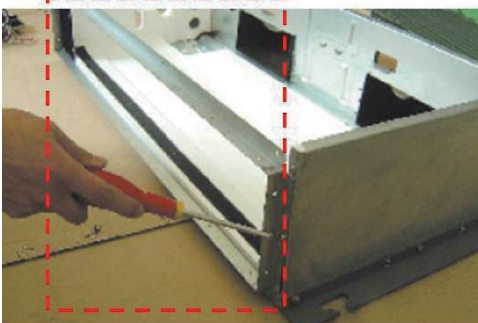

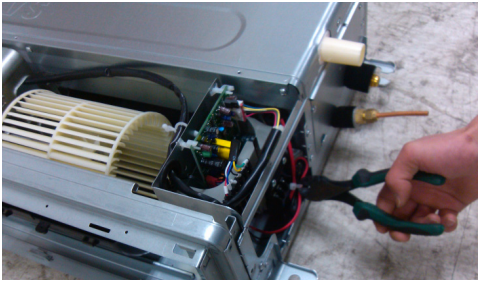
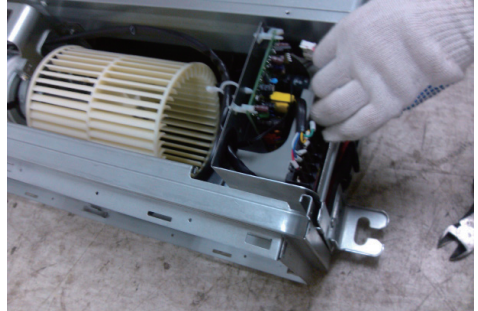
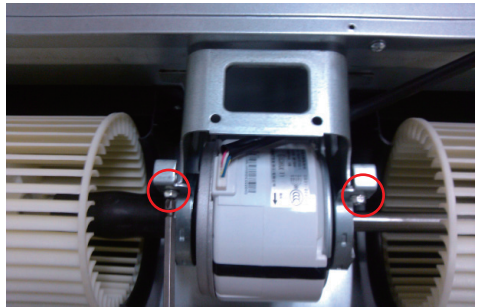

No	Parts	Procedure	Remark
4	Control In	<p>► The Control In should be disassembled after disassembling the Cover Control 1-3).</p> <p>1) Disassemble all Control Wires connected to the inside of PCB.</p> <p>2) In case of disassembling the PCB separately, disassemble the PCB from the case with pushing the hook after unscrewing the screw. - Unscrew 1 screw</p> <p>3) In case of disassembling the Case Control, disassemble the Case Control from the set after unscrewing the screw connected to the direction of Blower. - Disassemble if after disassembling the Cabinet Top Motor 1-1.</p>	

No	Parts	Procedure	Remark
5	Bracket Outlet	1) Disassemble the Bracket Outlet assembled on the Cabinet. - Unscrew 10 screws	

■ AC052RNLDKG/ AC071RNLDKG

No	Parts	Procedure	Remark
1	Motor & Blower	<p>1) Disassemble the Cabinet Bottom Fan. - Unscrew 10 screws</p> <p>2) Disassemble the Case Filter Pre.</p> <p>3) Disassemble frame-up. - Unscrew 2 screws</p> <p>4) Disassemble the case blower. - Unscrew 3 screws</p> <p>5) Disassemble cover control. - Unscrew 2 screws</p>	

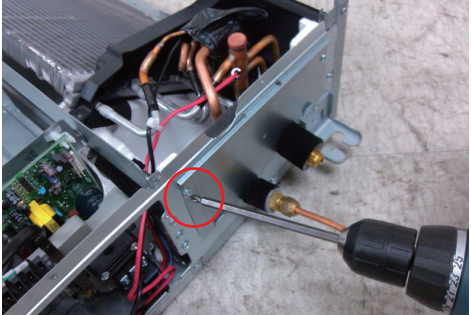
No	Parts	Procedure	Remark
		<p>5) Cut the cable-tie.</p> <p>6) Disconnect the wire between assy control out and motor.</p> <p>7) Disassemble the 2 Holder Motor. - Unscrew 2 screws</p> <p>8) After disassembling the Motor and Blower for the set, disassemble the Blower by use of 3mm wrench.</p> <p>9) Disassemble the both of Case Blower Out. - Unscrew 6 screws</p>	    

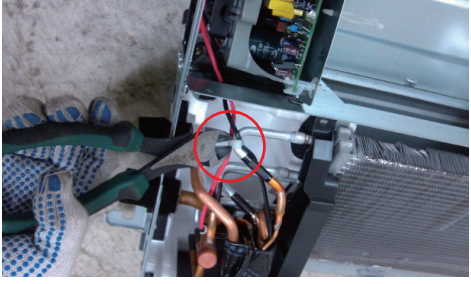
No	Parts	Procedure	Remark
2	Drain Pan	1) Disassemble the Cabinet Bottom Evap. - Unscrew 7 screws 2) Pull the Drain Pan Out.	 
3	EVAP	1) Disassemble the Cover Pipe. - Unscrew 2 screws 2) 1) Disassemble the Support Evap and hold evap. - Unscrew 3 screws 3) Disconnect the wire between assy control out and Evap.	  

No	Parts	Procedure	Remark
		4) Then pull the Evap out.	
4	Cushion	<p>1) Pull out the seal Cushion front.</p> <p>2) Disassemble the Seal Cushion Right. - Unscrew 1 screws.</p> <p>3) Disassemble the Assy Cushion LF. - Unscrew 1 screws.</p>	  

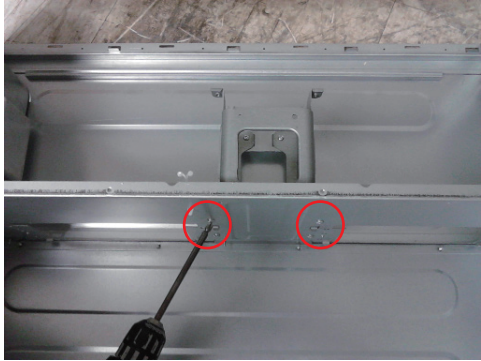
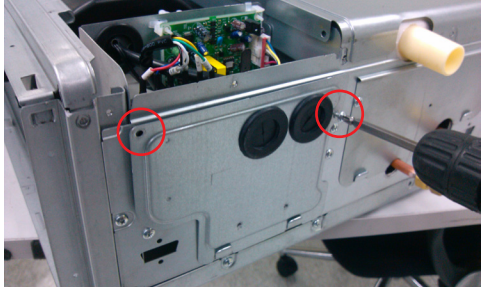
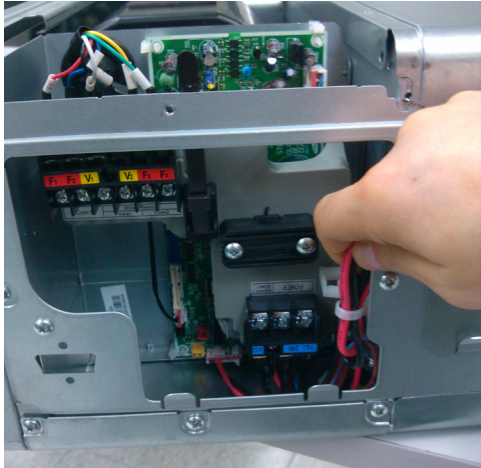
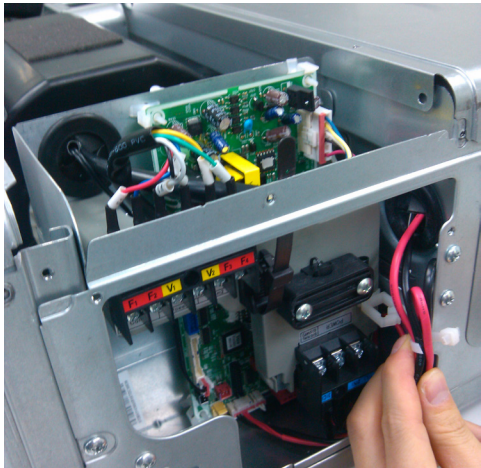
No	Parts	Procedure	Remark
5	Bracket Motor	1) Disassemble the Bracket Motor. - Unscrew 6 screws	
6	Control	1) Loosen 2 screws of Assy control in and Remove the assy control in. 2) Remove wires from wire saddle. 3) clip cable tie. (It is necessary to re-tie "cable tie" on re-assembly, then place in wire saddle .)	  



No	Parts	Procedure	Remark
7	Frame	1) Disassemble the Frame. - Unscrew 4 screws	 A close-up photograph of a silver metal frame being disassembled. A screwdriver is shown in the process of removing a screw from a bracket on the side of the frame. The background is a light-colored, textured surface, possibly a workbench or floor.

■ AC035RNMDKG/ AC052RNMDKG/ AC071RNMDKG

No	Parts	Procedure	Remark
1	Motor & Blower	<p>1) Disassemble the Cabinet Bottom Fan. - Unscrew 10 screws</p> <p>2) Disassemble the Case Filter Pre.</p> <p>3) Disassemble the 2 Case Blower Bottom. - Unscrew 4 screws</p> <p>4) Disassemble the Cover Control. - Unscrew 2 screws</p> <p>5) Cut the cable-tie</p>	

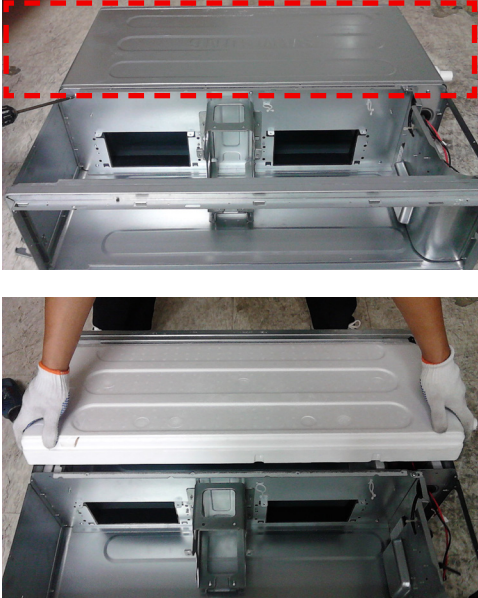
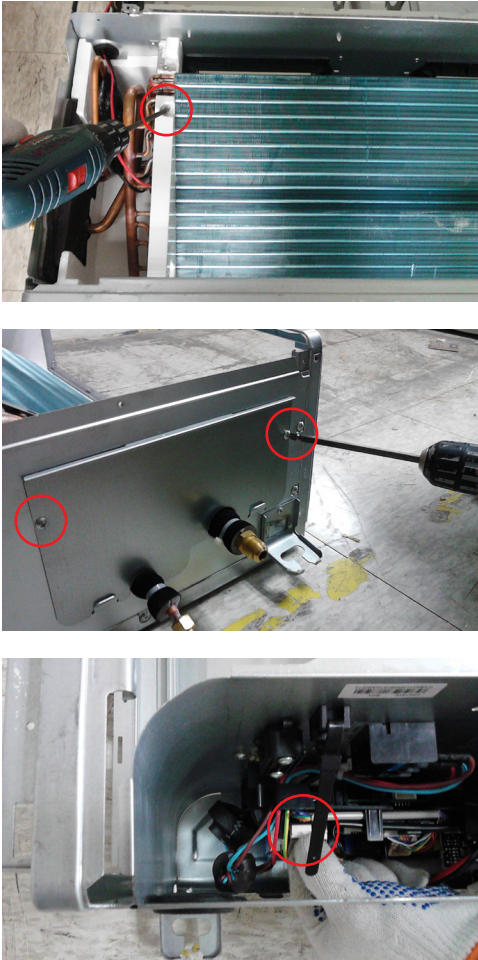
No	Parts	Procedure	Remark
		<p>6) Disconnect the wire between assy control out and motor.</p> <p>7) Disassemble the 2 Holder Motor. - Unscrew 2 screws.</p> <p>8) After disassembling the Motor and Blower for the set, disassemble the Blower by use of 3mm wrench.</p> <p>9) Disassemble the both of Case Blower Out - Unscrew 4 screws</p>	   

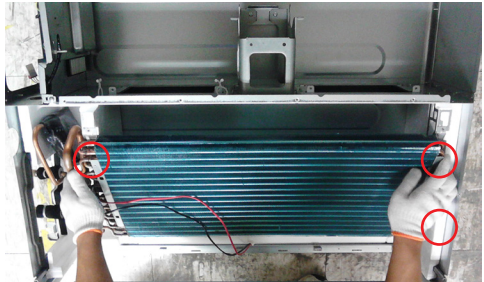

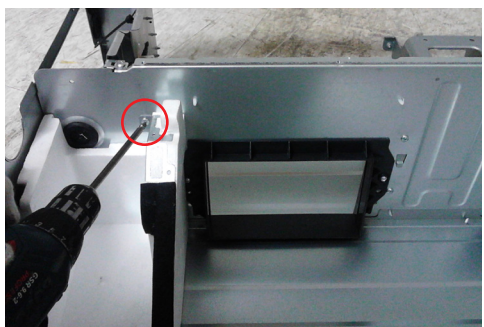
No	Parts	Procedure	Remark
2	Drain Pan	1) Disassemble the Cabinet Bottom Evap. - Unscrew 7 screws 2) Pull the Drain Pan Out.	
3	EVAP	1) Disassemble the Support Evap. - Unscrew 1 screws 2) Disassemble the Cover Pipe. - Unscrew 2 screws 3) Disconnect the wire between assy control out and Evap.	

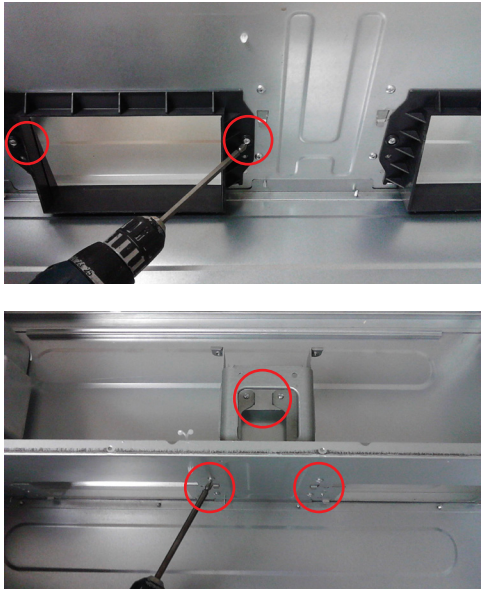
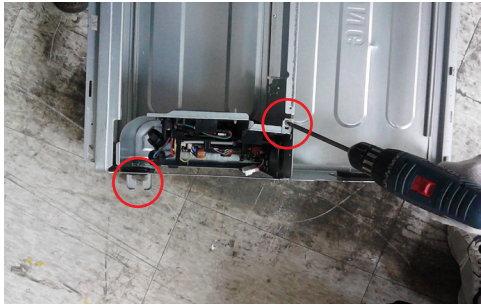
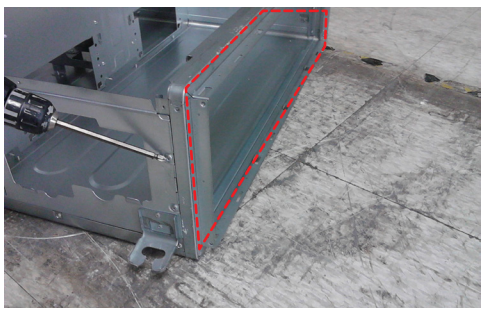



No	Parts	Procedure	Remark
		4) Disassemble the Evap. - Unscrew 3 screws. Then pull the Evap out	
4	Cushion	1) Pull out the Cushion. 2) Disassemble the Seal Cushion LF. - Unscrew 1 screws 3) Disassemble the Assy Cushion Right. - Unscrew 1 screws	  

No	Parts	Procedure	Remark
5	Case Blower & Bracket Motor	1) Disassemble the both of Case Blower Out. - Unscrew 4 screws 2) Disassemble the Bracket Motor. - Unscrew 6 screws	
6	Control	1) Disassemble the Case Control. - Unscrew 2 screws	
7	Frame	1) Disassemble the Frame. - Unscrew 6 screws	

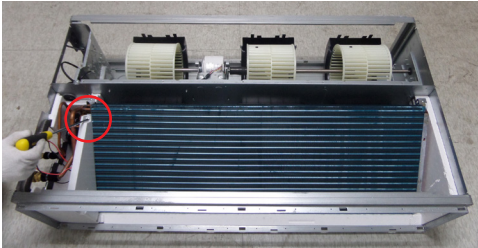
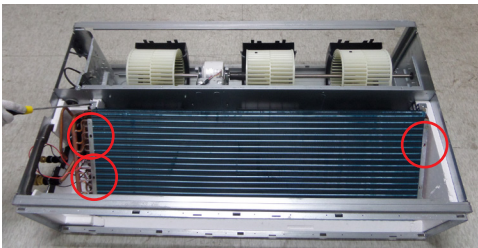
■ AC100RNMDKG/ AC120RNMDKG/ AC140RNMDKG

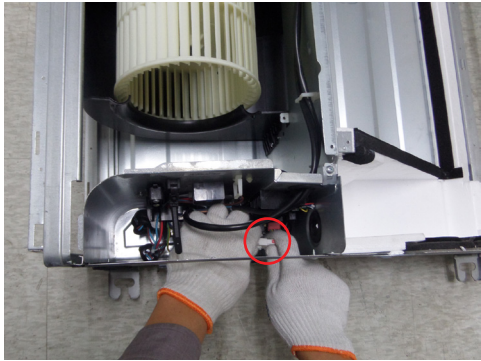
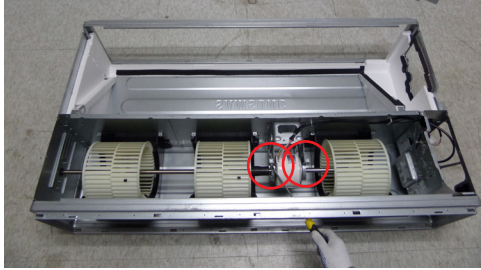
No	Parts	Procedure	Remark
1	Common	<p>1) Disassemble the Cabinet Bottom Fan. - Unscrew 11 screws</p> <p>2) Disassemble the Case Filter Pre.</p> <p>3) Disassemble the Cover Control. - Unscrew 2 screws</p> <p>4) Disassemble the Cabinet Bottom Evap. - Unscrew 8 screws</p>	   

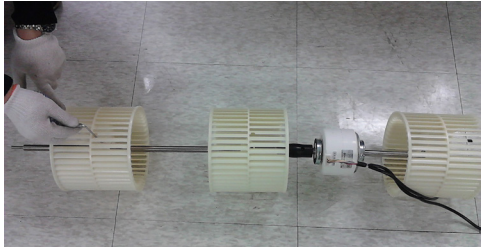
No	Parts	Procedure	Remark
2	Drain Pan & Evap	<p>1) Disassemble the Drain Pan from the set.</p> <p>2) Disassemble the 3 Case Blower Bottom. - Unscrew 6 screws</p> <p>3) Disassemble the Cover Pipe. - Unscrew 2 screws</p> <p>4) Disassemble the Support Evap. - Unscrew 1 screws</p> <p>5) Disassemble the Evap. - Unscrew 3 screws</p>	    

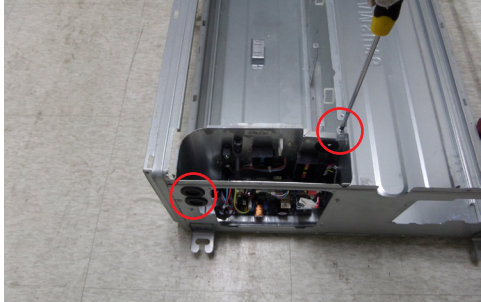
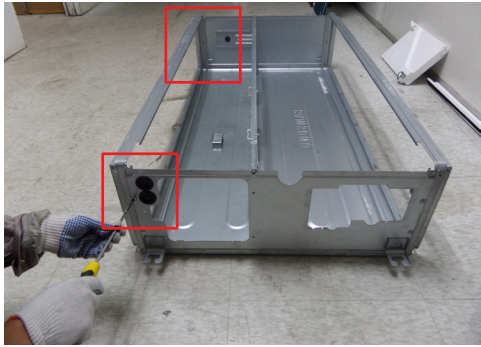

No	Parts	Procedure	Remark
3	Motor & Fan	<p>1) Disassembl the connection wire, the take the Motor Fan out</p> <p>2) Disassemble the 2 Holder Motor. - Unscrew 2 screws</p> <p>3) After disassembling the Motor and Blower for the set, disassemble the Blower by use of 3mm wrench.</p> <p>4) Disassemble the 3 Case Blower Top. - Unscrew 6 screws</p>	    

No	Parts	Procedure	Remark
		<p>5) Disassemble the Bracket Motor. - Unscrew 6 screws</p> <p>6) Disassemble the 3 Case Blower Out. - Unscrew 6 screws</p>	 <p>The Remark column contains three photographs illustrating the disassembly process. The first photo shows a person using a screwdriver to remove screws from a motor bracket located on the back panel of the refrigerator. A red box highlights the bracket. The second photo shows a person using a screwdriver to remove screws from a blower out component on the back panel. A red circle highlights the blower out. The third photo shows a person using a screwdriver to remove screws from three blower out components on the back panel. Red circles highlight each of the three blower outs.</p>

No	Parts	Procedure	Remark
4	Cushion	1) Disassemble the Assy Cushion Right. - Unscrew 1 screws 2) Disassemble the Seal Cushion LF. - Unscrew 1 screws	
5	Control	1) Disassemble the Case Control. - Unscrew 2 screws	
6	Frame	1) Disassemble the Frame. - Unscrew 6 screws	

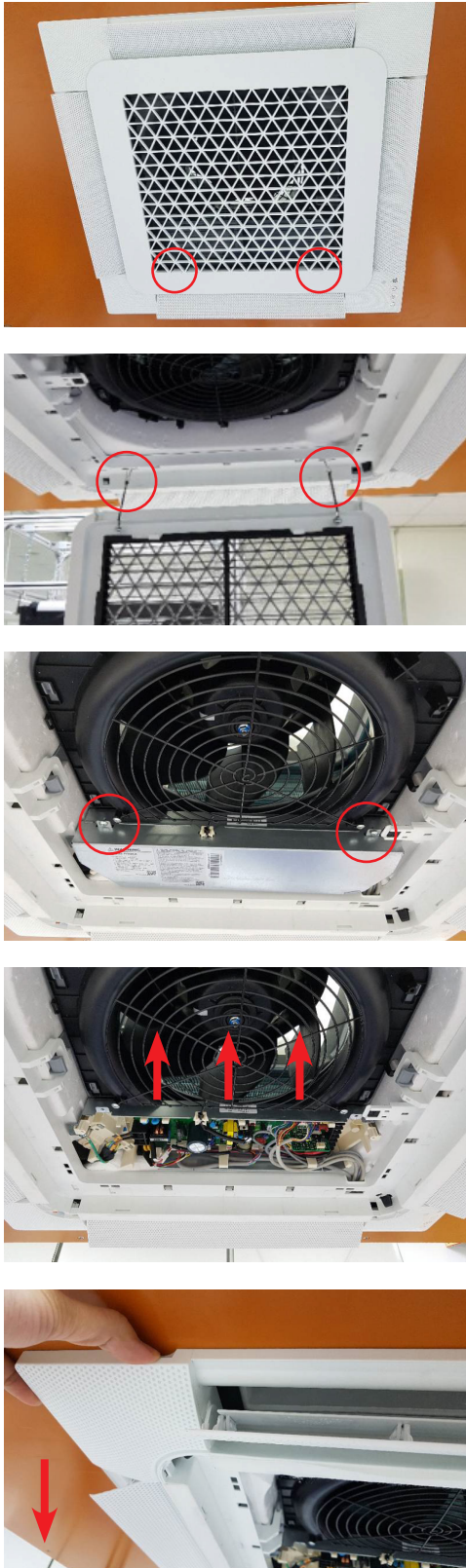
■ AC026RNNDKG, AC035RNNDKG, AC052RNNDKG, AC071RNNDKG

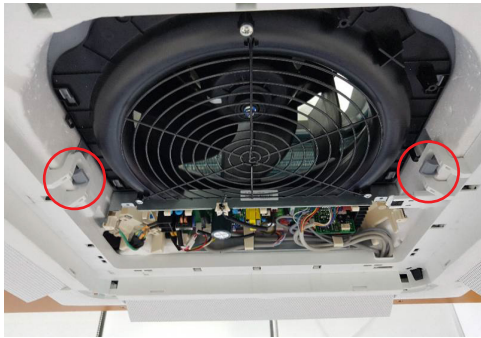
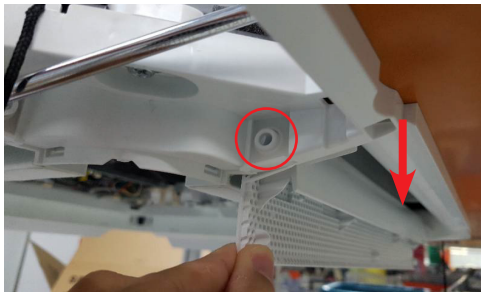
No	Parts	Procedure	Remark
1	Panel	<p>1) Pull both hooks and take the grille downward. Two safety clips are mounted to the front grille to prevent it from dropping.</p> <p>2) Detach the safety clip and take up the grille.</p> <p>3) Remove the 2 fixed screws to remove the Control-Box Cover. (Use +Screw Driver)</p> <p>4) Remove the remote control-receiver, blade connector and humidity sensor wires from the PBA. (4EA)</p> <p>5) Push the 4 panel corners and cover downwards to remove it.</p>	

No	Parts	Procedure	Remark
		<p>6) Disassemble the bolts that are assembled with the indoor unit at the 4 panel corners.</p> <p>7) Press the Hangers at both sides of the panel inwards, to remove it from the indoor unit's hook. Remove the panel from the indoor unit.</p>	 
2	Blade	1) Remove the hinge-blade and blade.	
3	Display PBA	<p>1) Remove the cover display.</p> <p>2) Remove the cover PBA from the cover display.</p>	 

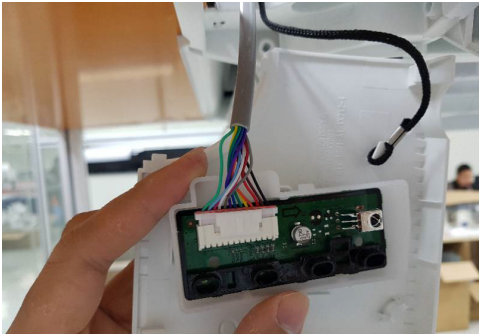
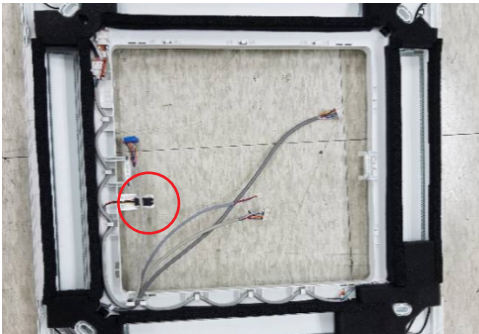
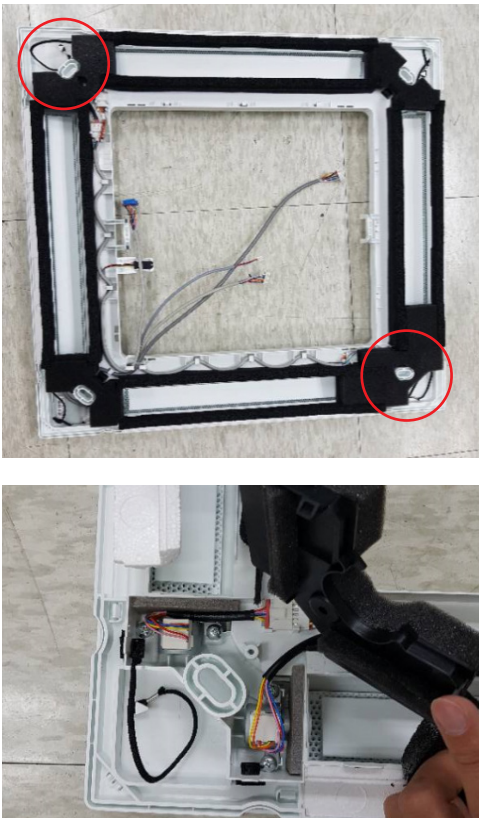
No	Parts	Procedure	Remark
		3) Disconnect the connector wire from the PBA.	
4	Humidity Sensor	1) Remove the humidity sensor from the panel.	
5	Step motor	<p>1) Unscrew 2 screws on cover motor. (Use +Screw Driver)</p> <p>2) Remove 2 cover motor.</p> <p>3) Remove the 2 fixed screws and disassemble the step motor. (Use +Screw Driver)</p>	

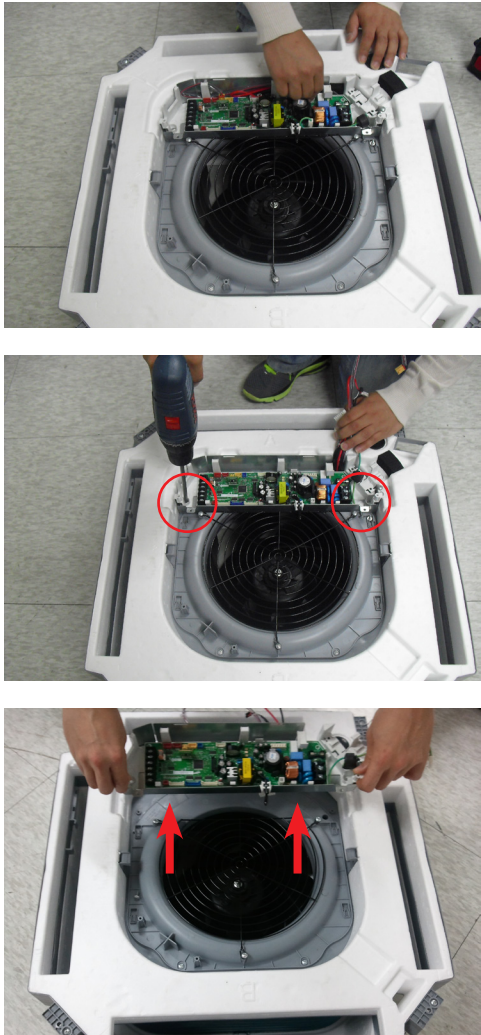
No	Parts	Procedure	Remark
6	Control-Box	<p>1) Disconnect the Connector Wire that is connected to the indoor unit's PBA.</p> <p>2) Unscrew the 2 fixed screws on both sides of the Control Box, and disassemble the Control Box from the indoor unit. (Use +Screw Driver)</p>	

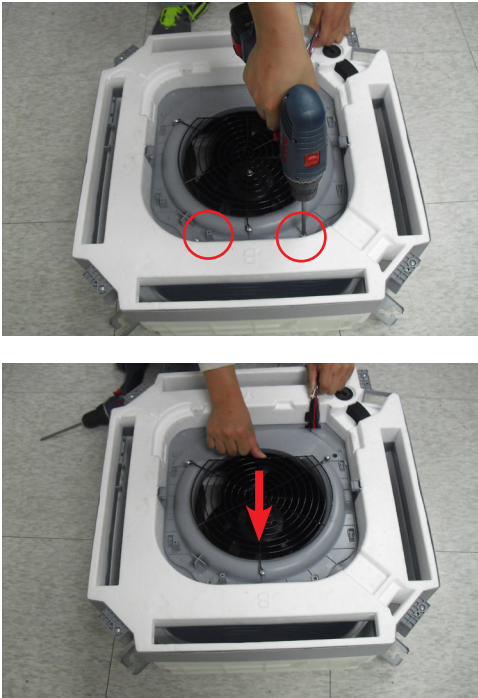
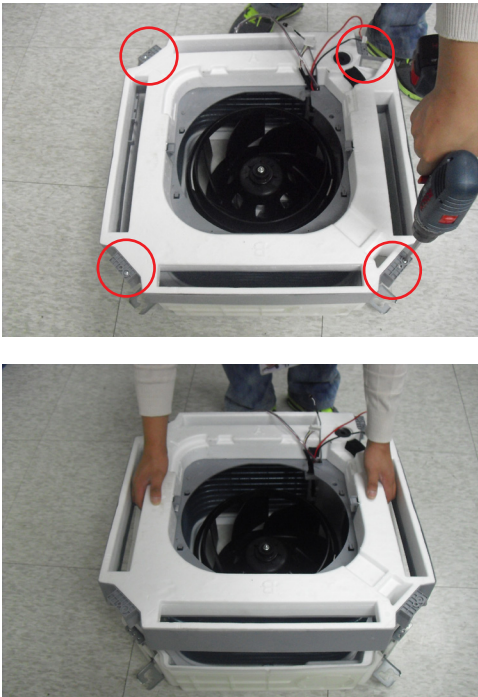
No	Parts	Procedure	Remark
7	Bell-Mouth	<p>1) Unscrew the screw fixed on the Bell-Mouth. (Use +Screw Driver)</p> <p>2) Push the Bell-Mouth in the direction opposite to where it's installed on the Control-Box to remove it.</p>	
8	Drain Pan	<p>1) Unscrew the screws on the 4 corners of the indoor unit. (Use +Screw Driver)</p> <p>2) Remove the Drain Pan from the indoor unit.</p>	

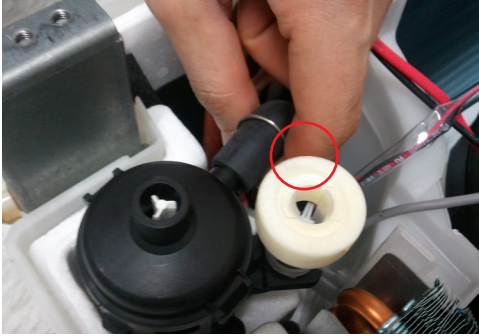
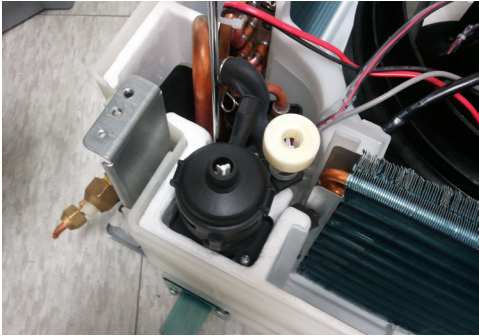
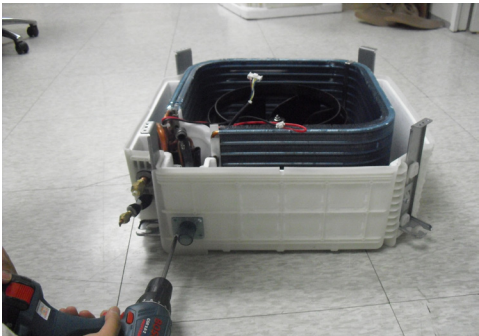
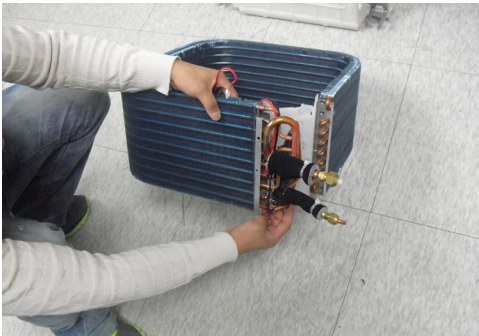
No	Parts	Procedure	Remark
9	Drain Pump & Hose	<p>1) Remove the 2 fixed screws and disconnect the white drainage hose from the Drain Pump. (Use +Screw Driver)</p> <p>2) Remove the 2 screws and take the Drain-Hose out from the indoor unit to disassemble the transparent Drain-Hose fixed on the side of the indoor unit. (Use +Screw Driver)</p>	  
10	Evap. Temperature Sensor	<p>1) Use your hand to remove the temperature sensor attached to the Evap Pipe along with the fixing clip.</p>	

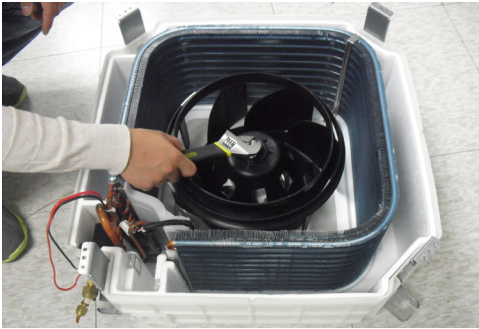
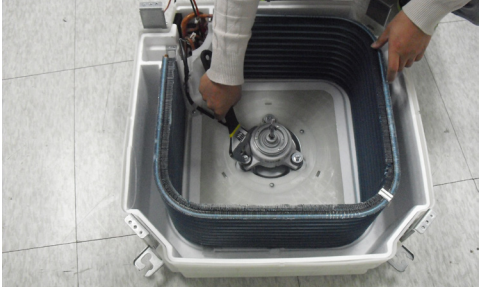
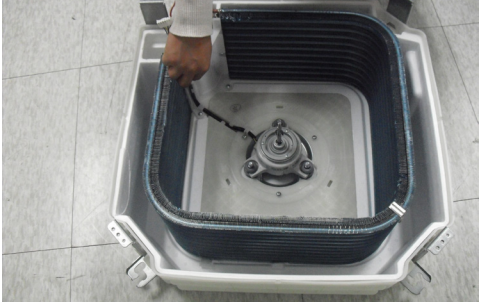
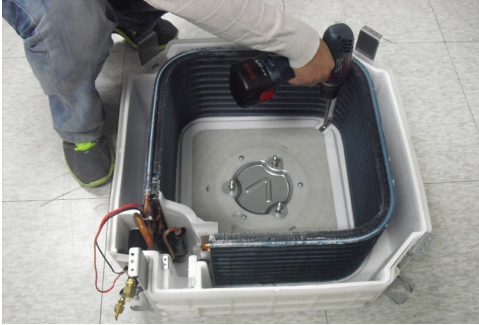
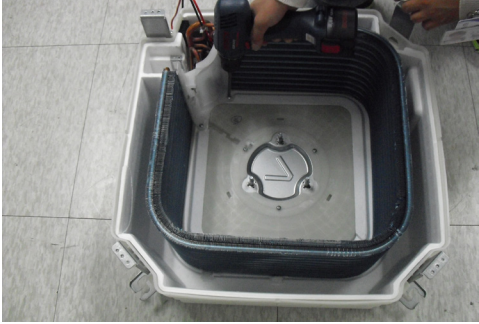
No	Parts	Procedure	Remark
11	Fan & Motor	<p>1) Turn the hexangular nut attached to the top of the Fan counterclockwise to remove it. Take the Fan out of the Motor.</p> <p>2) Turn the three hexangular nuts on the Motor counterclockwise to remove the nuts. Take the Motor Wires attached to these three locations out with your hands prior to removing the Motor.</p>	  
12	Evaporator	<p>1) Remove the screws of the Steel Holder Evaps that are used to fix the Heat Exchanger, and then remove it. (Use +Screw Driver)</p> <p>2) Remove the 2 fixing screws of the Partition Evap at the Heat Exchanger's In/ Out Pipe. (Use +Screw Driver)</p>	 



No	Parts	Procedure	Remark
		<p>3) Remove the screw of the Cover Pipe that is used to fix the In/ Out Pipe. Remove the In/ Out Pipe. (Use +Screw Driver)</p> <p>4) Remove the Heat Exchanger from the indoor unit's cabinet.</p>	  

■ AC026RNJDKG/ AC035RNJDKG/ AC052RNJDKG

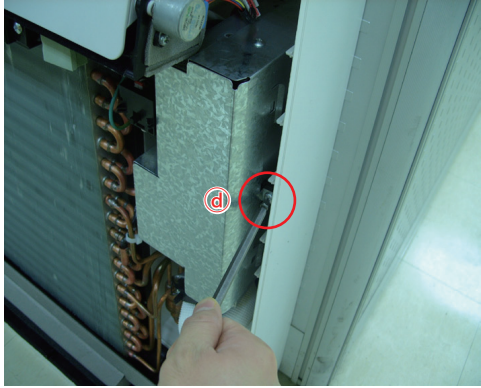
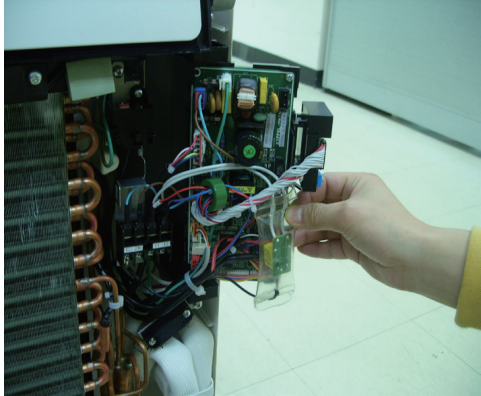
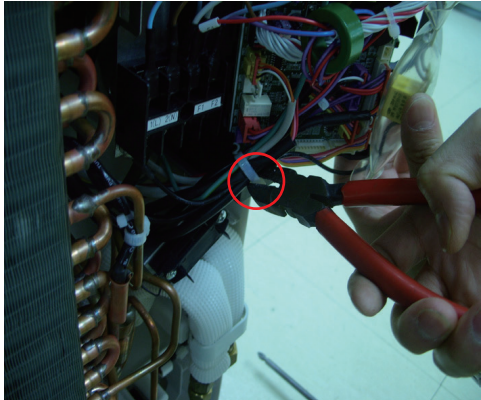
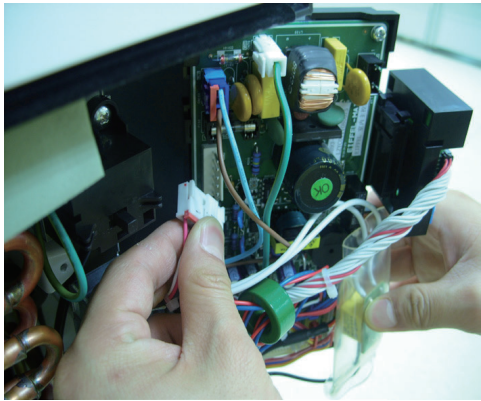
No	Parts	Procedure	Remark
1	Cabi Parts	<p>1) Open the Panel Front (a). Remove the Clip Wire (b).</p> <p>2) Release 4 screws on the Body Front (c).</p> <p>3) Open the Body Front (c) by pulling from bottom of the part.</p>	

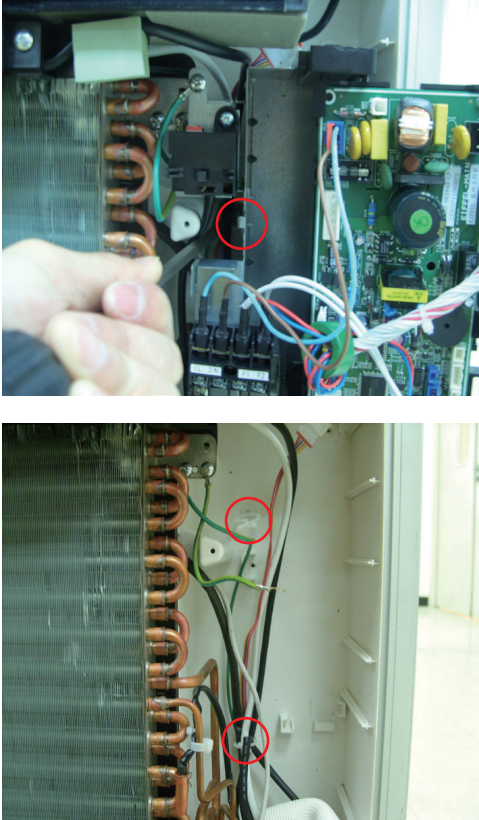
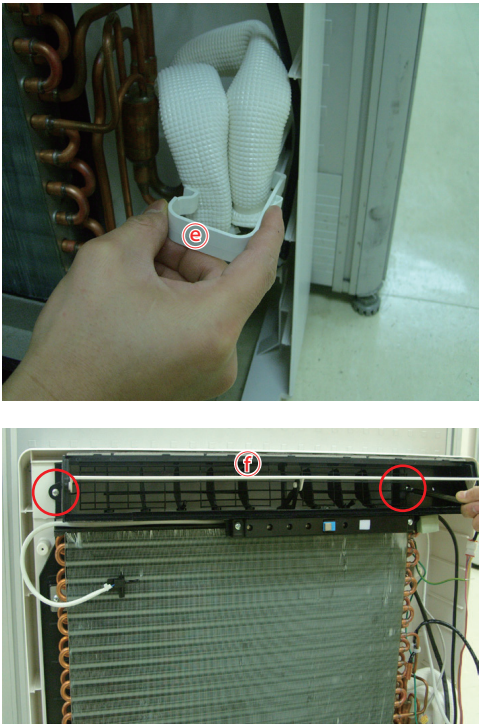
No	Parts	Procedure	Remark
2	Electrical Parts	<p>1) Open the cover of Control Box (d).</p> <p>2) Pull the PBA out along the slide guide.</p> <p>3) Cut the Cable tie.</p> <p>4) Pull all wires out from the PBA.</p>	   

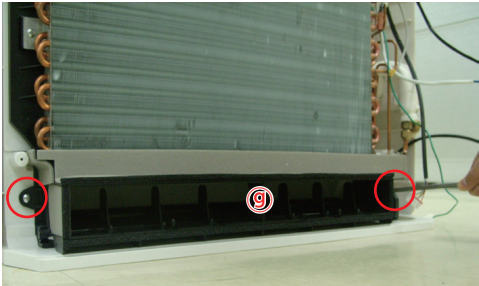

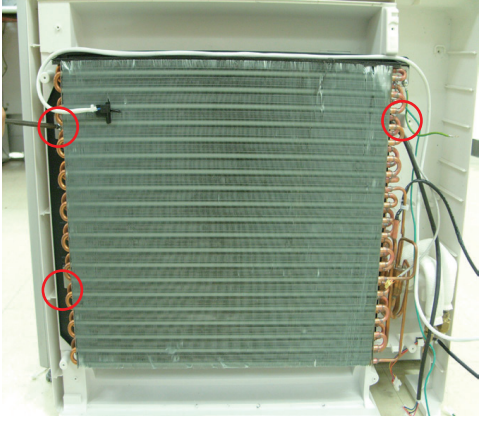

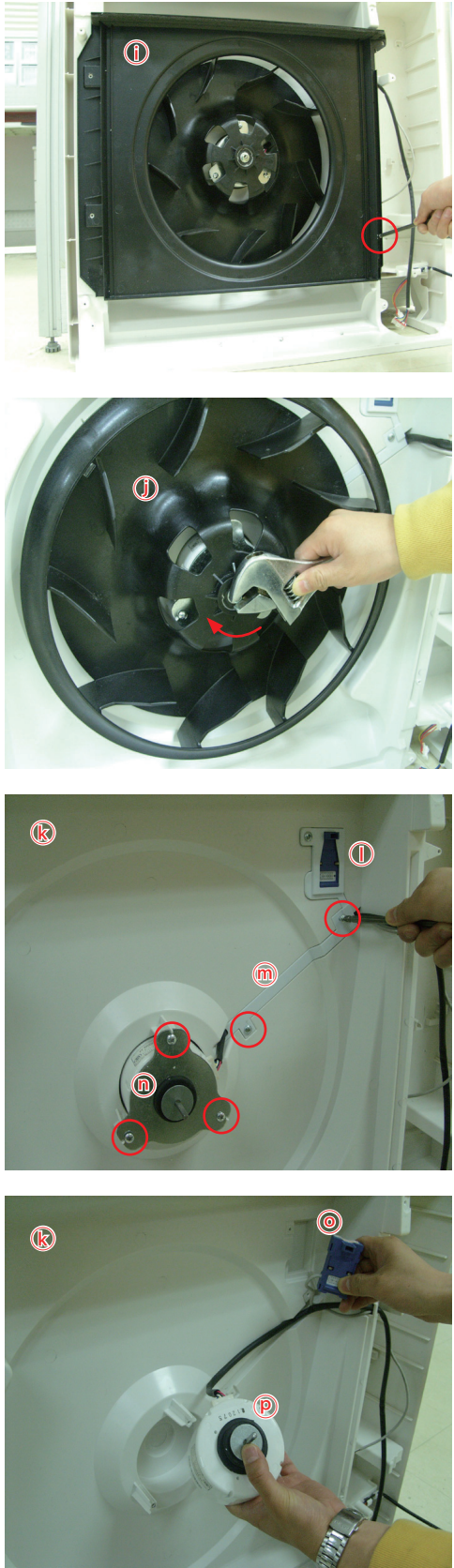
No	Parts	Procedure	Remark
		<p>5) Release the 2 screws. (one is top of the C-Box, the other is left of it)</p> <p>6) Release 2 Hold Wires and pull all wires out from it.</p>	
3	Blowing & Evap Part	<p>1) Pull the Bracket Pipe (e) out.</p> <p>2) Release 2 screws and pull Top Discharge Kit (f) out.</p>	

No	Parts	Procedure	Remark
		<p>3) Release 2 screws and pull Bottom Discharge Kit (9) out.</p> <p>4) Disconnect the Step Motor wire (h) from the connect wire . This part is right side of the Bottom Discharge Kit (9).</p> <p>5) Pull Bottom Discharge Kit (9) Out from the bottom of it.</p> <p>6) Release 3 screws and pull the Evap out from top to bottom direction.</p>	   

No	Parts	Procedure	Remark
4	Fan Part	<p>1) Release 1 screw and pull the Bell Mouth (i) out.</p> <p>2) Release the Nut and pull Fan Turbo (j) out.</p> <p>3) Release 6 screw on the Body Back (k). Pull the Cap VIRUS DOCTOR (l), Bracket Wire (m) and Bracket Motor (n) out.</p> <p>4) Pull the VIRUS DOCTOR Kit (o) and Motor (p) out from the Body Back (k).</p>	

3-2 Outdoor unit

■ AC026RXADKG/ AC035RXADKG

No	Parts	Procedure	Remark
1	common work	<p>⚠ You must turn off the Power before disassembly.</p> <p>1) loosen 1 pcs screw of cover control, and detach it.</p> <p>2) loosen 5 pcs screws on both right and left cabinet side edges and to detach the cover-top.</p> <p>3) Loosen 7 screws fixed to disassemble cabinet-front, and detach it.</p>	   

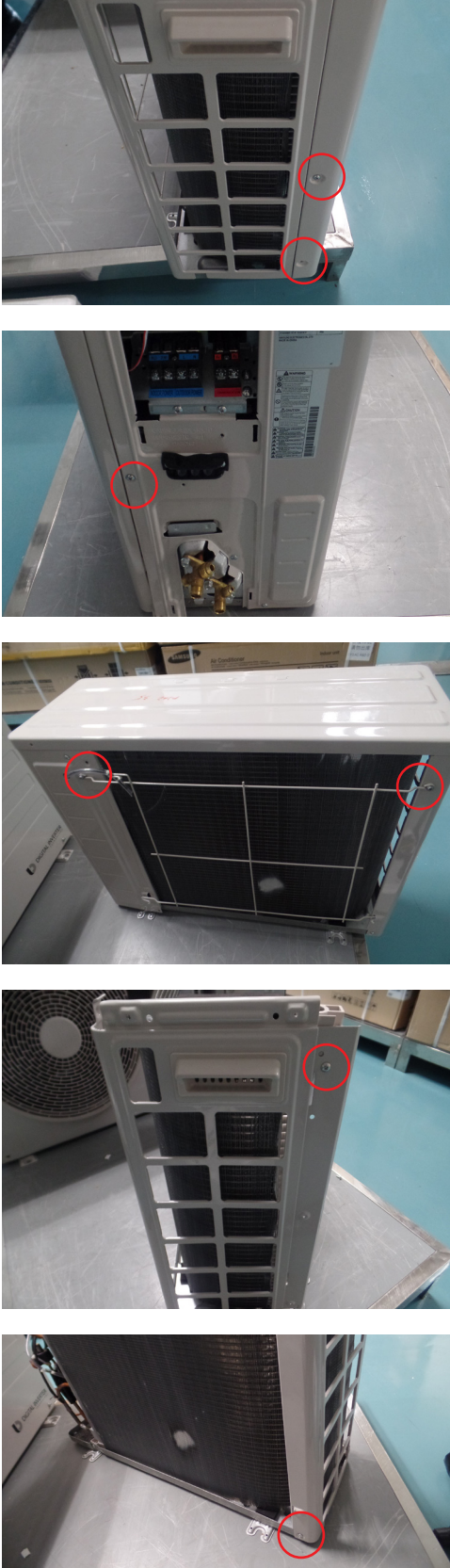

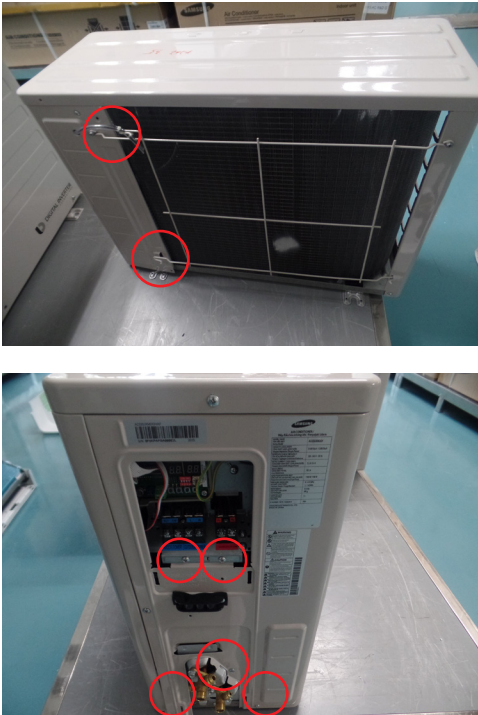
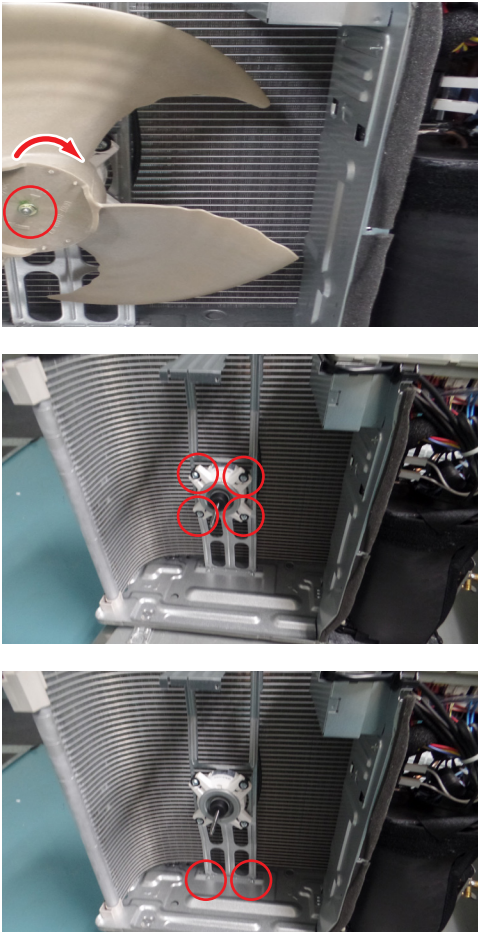
No	Parts	Procedure	Remark
	common work	<p>4) loosen 2 screws to disassemble steel-bar.</p> <p>5) Loosen 2 screws to disassemble the cabi left and detach it.</p>	

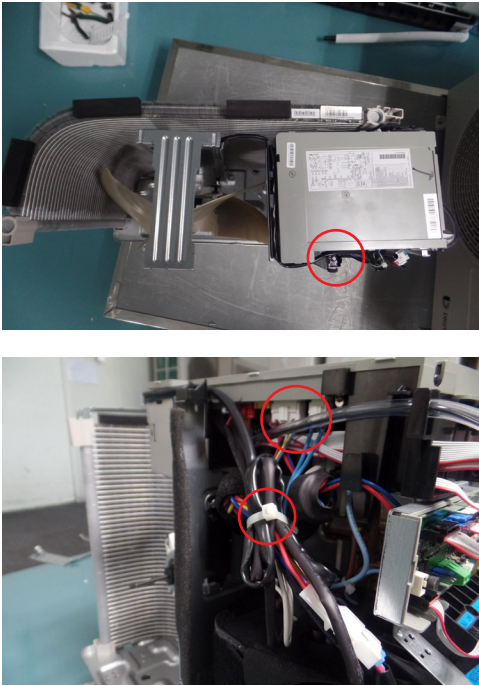
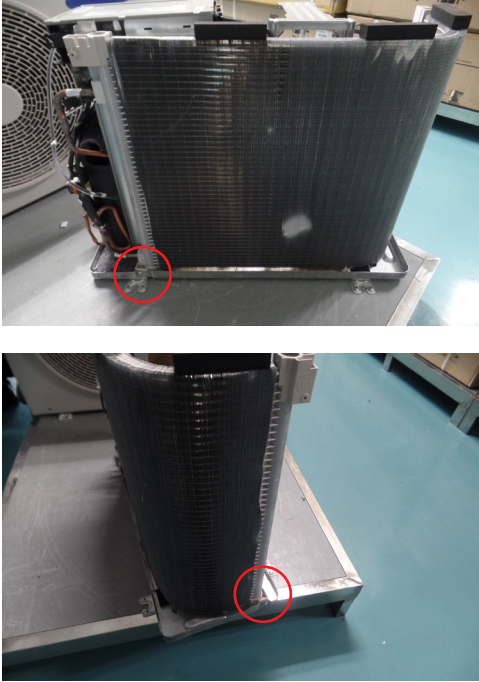
No	Parts	Procedure	Remark
	common work	6) Loosen 7 screws to disassemble the cabi right and detach it.	
2	fan & motor	<p>1) loosen 1 screw as indication and detached the fan.</p> <p>2) loosen 4 pcs motor screws and disconnect the wire between assy control out and motor.</p> <p>3) loosen 2 pcs bracket-motor screw and detach it.</p>	

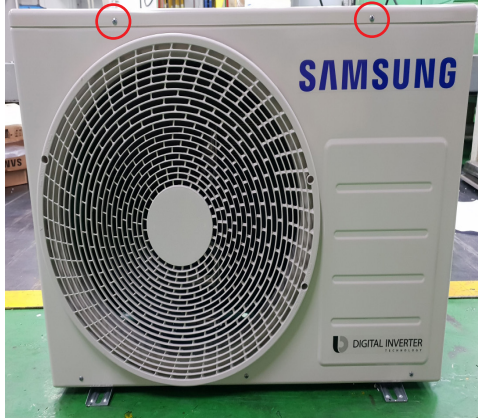

No	Parts	Procedure	Remark
3	assy control out	<p>1) Disconnect fixing 1 screw from cover. - control</p> <p>2) detach several connections from assy control out, take out assy control out.</p>	
4	Heat exchanger	<p>1) Release the refrigerant at first</p> <p>2) Loosen fixing screw on both side.</p> <p>3) disassembly the pipes in both inlet and outlet with welding torch.</p> <p>4) detach the heat exchanger.</p>	

No	Parts	Procedure	Remark
5	compressor	<p>1) disconnect the compressor lead wire.</p> <p>2) disassembly the felt comp sound. loosen the 3 bolts at the bottom.</p> <p>⚠ When removing the compressor, Heat Exchanger, and Pipe, purge the refrigerant inside the Compressor completely and remove the pipe with a welding flame.</p>	

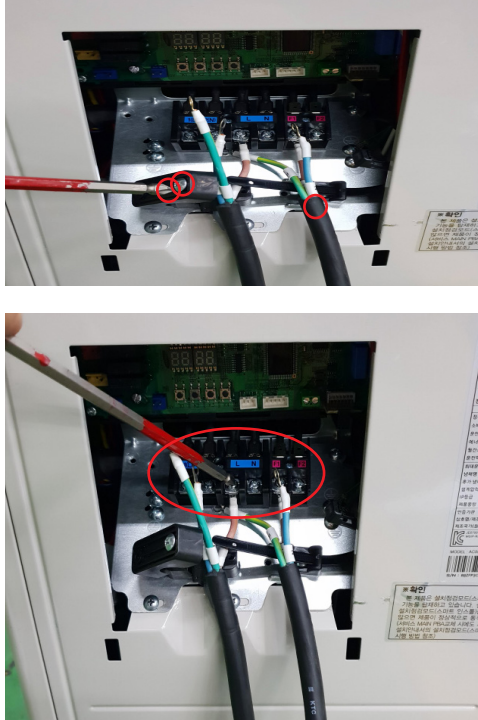
■ AC052RXADKG



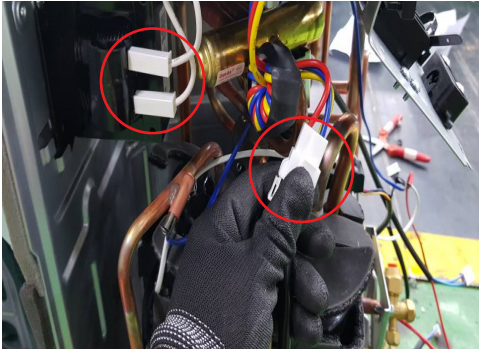
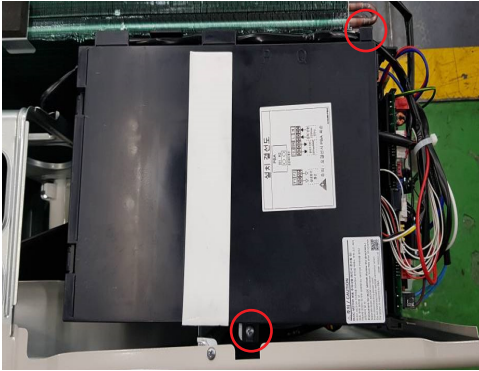

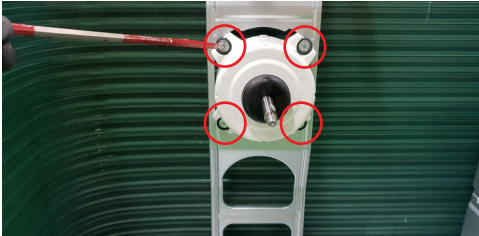
No	Parts	Procedure	Remark
1	Cabi Top	1) Unscrew and remove 8 screws on each side of the Cabinet-Top. (Use + Screw Driver)	
2	ASS'Y COVER CONTROL	1) Unscrew and remove a screw of Cover-Control. (Use + Screw Driver)	
3	Outdoor and indoor unit's power cable and communication cable	<p>⚠ Make sure shutting the power off supply before disassembling</p> <p>1) Unscrew 2 fix screws under cable holders and remove.</p> <p>2) Get rid of cable tie of communication cable.</p> <p>3) Unscrew the numbers of screws on terminal block and separate power and communication 'Ring' cables from terminal block.</p>	

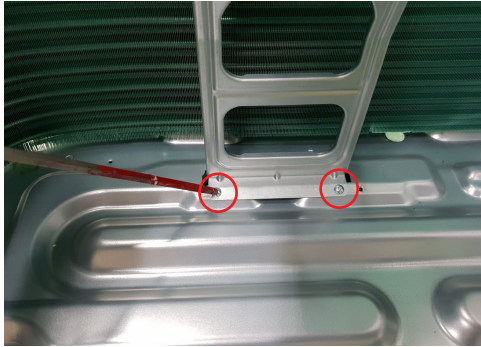
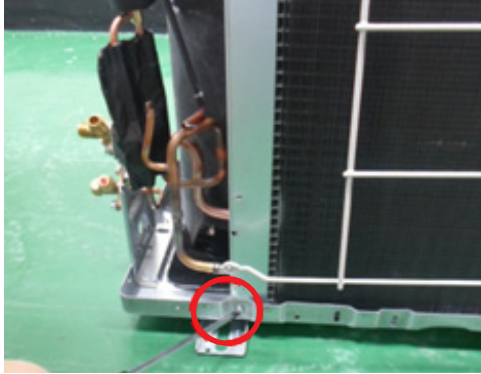
No	Parts	Procedure	Remark
4	ASS'Y CABINET SIDE RH	1) Unscrew and remove 9 screws on Cabinet-side rh. (Use + Screw Driver)	 <p>The top photograph shows the right side of the cabinet with a terminal block. Nine screws are circled in red: two on the top edge, two on the bottom edge, and five on the side edge. The bottom photograph shows the side of the cabinet with a white metal ladder. Three screws are circled in red: one at the top, one in the middle, and one at the bottom.</p>
5	ASS'Y CABINET FRONT	1) Unscrew and remove 8 screws on Assy Cabinet Front. (Use + Screw Driver)	 <p>The top photograph shows the front of the cabinet with a large circular fan grille. The 'SAMSUNG' logo is visible on the right side, and 'DIGITAL INVERTER' is printed at the bottom right. Eight screws are circled in red: one on the top edge, one on the bottom edge, and six on the side edge. The bottom photograph shows the front of the cabinet with the fan grille removed, revealing the internal components. Eight screws are circled in red: one on the top edge, one on the bottom edge, and six on the side edge.</p>

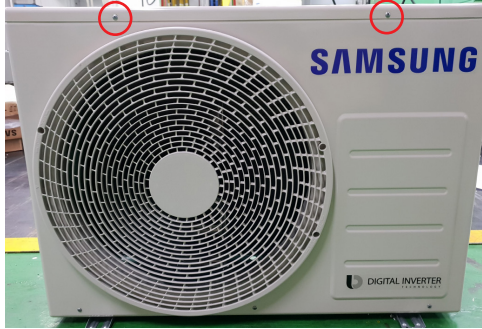

No	Parts	Procedure	Remark
6	ASS'Y CONTROL OUT	<p>1) Disconnect and Separate 5 Connectors of wire from Assy Control Out.</p> <p>2) Separate Comp wire and Reactor wire from each object.</p> <p>⚠ (When you disconnect BLDC motor connector you have to cut the power off first and disconnect 30 seconds later And Make sure that is impossible to connect and disconnect BLDC motor connector when the power is on)</p> <p>3) Unscrew and remove 2 screws on of Assy Control out.</p>	  
7	FAN PROPELLER + MOTOR	<p>1) Take Fan Propeller apart.</p> <p>2) Unscrew and remove 4 screws on Motor to take apart Motor. (Use + Screw Driver)</p>	 

No	Parts	Procedure	Remark
8	ASS'Y BRACKET MOTOR	1) Unscrew and remove 2 screws on to take apart Bracket Motor. (Use + Screw Driver)	
9	Heat Exchanger	1) Purge the Refrigerant first. 2) Unscrew the fix screw. 3) Separate the pipe from the Entrance and Exist by using a welder. 4) Separate Heat Exchanger from Unit. ⚠ When removing the Compressor, Heat Exchanger, and Pipe, Purge the Refrigerant inside the Compressor completely and remove the pipe with a weld-ing flame.	

■ AC071RXADKG

No	Parts	Procedure	Remark
1	Cabi Top	1) Unscrew and remove 8 screws on each side of the Cabinet-Top. (Use + Screw Driver)	
2	Ass'y cover control	1) Unscrew and remove a screw of Cover-Control. (Use + Screw Driver)	
3	Outdoor and indoor unit's power cable and communication cable	<p>⚠ Make sure shutting the power off supply before disassembling.</p> <p>1) Unscrew 2 fix screws under cable holders and remove.</p> <p>2) Get rid of cable tie of communication cable.</p> <p>3) Unscrew the numbers of screws on terminal block and separate power and communication 'Ring'cables from terminal block.</p>	 

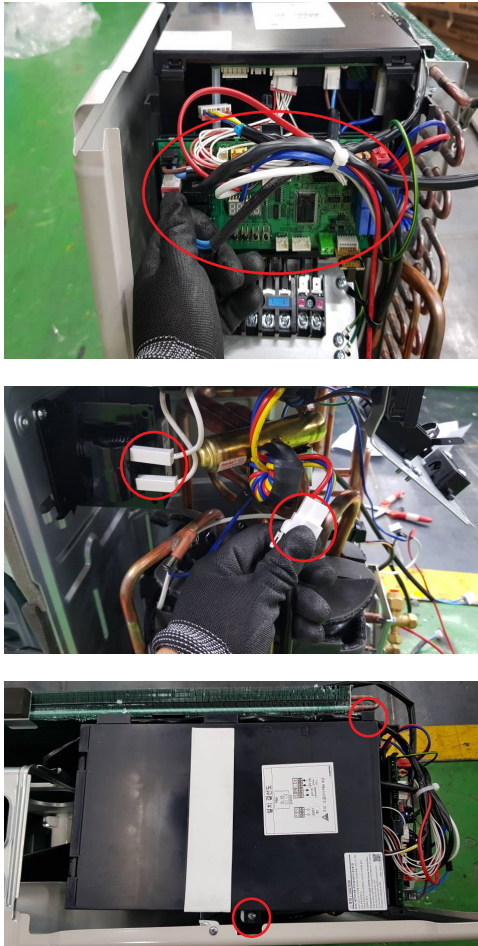

No	Parts	Procedure	Remark
4	Ass'y cabinet side rh	1) Unscrew and remove 10 screws on Cabinet-side rh. (Use + Screw Driver)	
5	Ass'y cabinet front	1) Unscrew and remove 7 screws on Assy Cabinet Front. (Use + Screw Driver)	

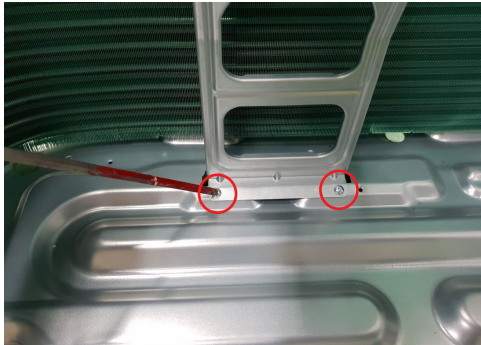
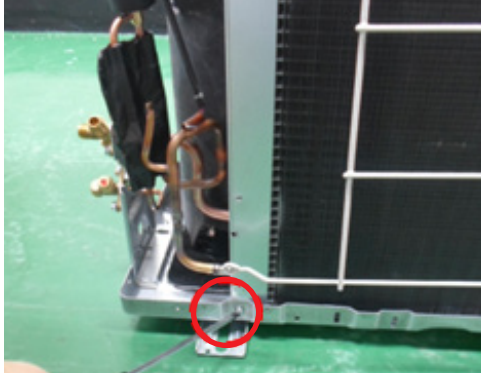

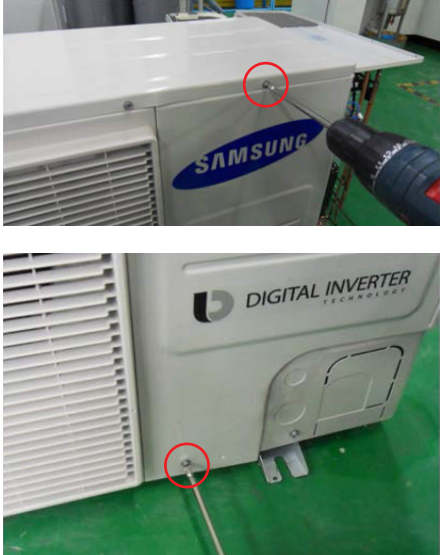
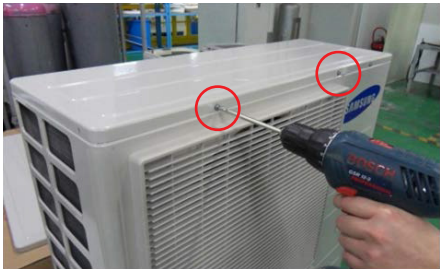

No	Parts	Procedure	Remark
6	Ass'y control out	<p>1) Disconnect and Separate 5 Connectors of wire from Assy Control Out.</p> <p>2) Separate Comp wire and Reactor wire from each object.</p> <p>⚠ (When you disconnect BLDC motor connector you have to cut the power off first and disconnect 30 seconds later And Make sure that is impossible to connect and disconnect BLDC motor connector when the power is on)</p> <p>3) Unscrew and remove 2 screws on of Assy Control out.</p>	
7	Fan propeller + Motor	<p>1) Take Fan Propeller apart.</p> <p>2) Unscrew and remove 4 screws on Motor to take apart Motor. (Use + Screw Driver)</p>	

No	Parts	Procedure	Remark
8	Ass'y bracket Motor	1) Unscrew and remove 2 screws on to take apart Bracket Motor. (Use + Screw Driver)	
9	Heat Exchanger	1) Purge the Refrigerant first. 2) Unscrew the fix screw. 3) Separate the pipe from the Entrance and Exist by using a welder. 4) Separate Heat Exchanger from Unit. ⚠ When removing the Compressor, Heat Exchanger, and Pipe, Purge the Refrigerant inside the Compressor completely and remove the pipe with a weld-ing flame.	

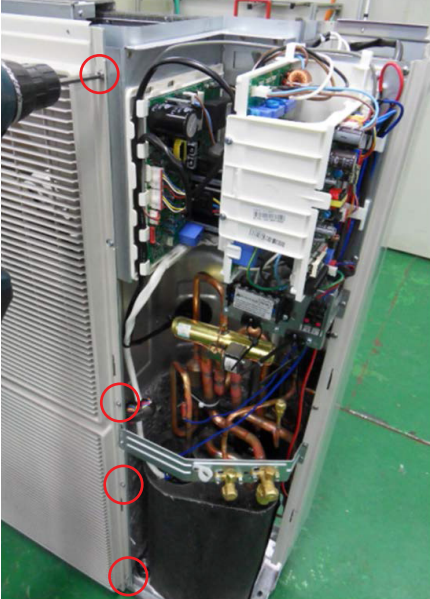

🔗 Reassembly procedures are in the reverse order of dissassembly procedures.

■ AC140RXAD*G

No	Parts	Procedure	Remark
1	Cabi Front RH	<p>⚠ You must turn off the Power before disassembly.</p> <p>1) Unscrew and remove two mounting screw in the Cabinet Front RH. (Use +Screw Driver)</p>	
2	Cabi Top	<p>1) Unscrew and remove 9 screws on each side of the Cabinet-Top. (Use +Screw Driver)</p>	
3	Cabi Install Front	<p>1) Unscrew and remove 1 screw in the Cabinet-Install Front. (Use +Screw Driver)</p>	
4	Guard Cond	<p>1) Pull the sensor from Guard Cond.</p> <p>2) Unscrew and remove 4 screws in the Guard Cond. (Use +Screw Driver)</p>	

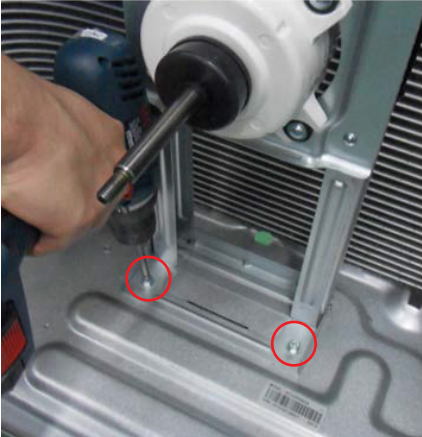
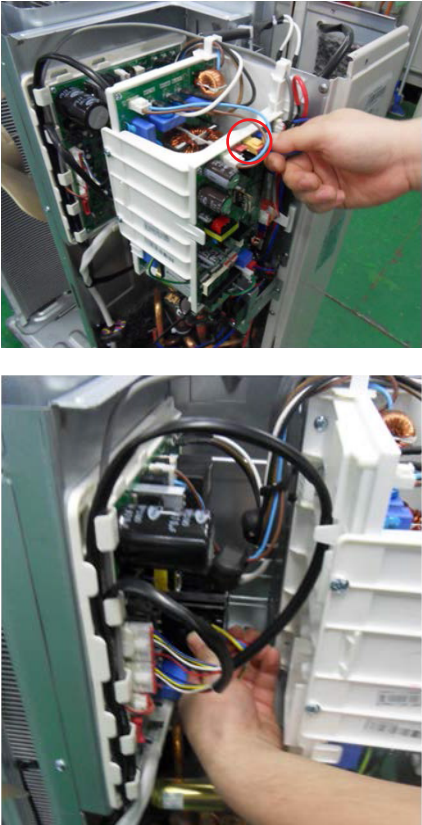
No	Parts	Procedure	Remark
5	Cabi Back RH	1) Pull the sensor from Cabi Back RH. 2) Unscrew and remove 4 screws on each side of the Cabinet Back RH. (Use +Screw Driver)	
6	Cabi Install Back	1) Unscrew and remove 1 screw in the Cabinet-Install Back. (Use +Screw Driver)	
7	Cabi Front LF	1) Unscrew and remove 10 screws in the Cabinet-Front LF. (Use +Screw Driver)	
8	Fan	1) Turn 2 mounting nuts as shown in the picture and remove it. (Use Adjustable Wrench)	

No	Parts	Procedure	Remark
9	Motor	1) Separate the Fan Propeller. 2) Unscrew and remove the 8 Motor mounting screws. (AC100~/ EU = 4 Moter mounting screws) (AC120~/ EU = 4 Moter mounting screws) (Use +Screw Driver) 3) Disconnect the Motor wire From Ass'y Control Out.	
10	Bracket Motor	1) Unscrew and remove 2 mounting screws in Bracket Motor. (Use +Screw Driver)	
11	Control Out	1) Disconnect 4 Connecters From Ass'y Control Out. 2) Unscrew and remove 1 mounting screw in Control Out. (Use +Screw Driver) 3) Separate Ass'y Control Out.	

No	Parts	Procedure	Remark
12	Cabi Front RH	1) Purge the Coolant first. 2) Unscrew and remove 2 mounting screws in Service Valve. (Use +Screw Driver) 3) Separate the pipe from the Entrance/ Exit using a welder. ⚠ When removing the compressor, Heat Exchanger, and Pipe, purge the Coolant inside the Compressor completely and remove the pipe with a welding flame.	
13	Cabi Top	1) Unscrew and remove 2 mounting screws in Service Valve. (Use +Screw Driver) 2) Separate the pipe from the Entrance/ Exit using a welder.	

4. Troubleshooting

4-1 Setting an indoor unit address and installation option

► Set the indoor unit address and installation option with remote controller option.

Set the each option separately since you cannot set the ADDRESS setting and indoor unit installation setting option at the same time. You need to set twice when setting indoor unit address and installation option.

4-1-1 The procedure of setting option

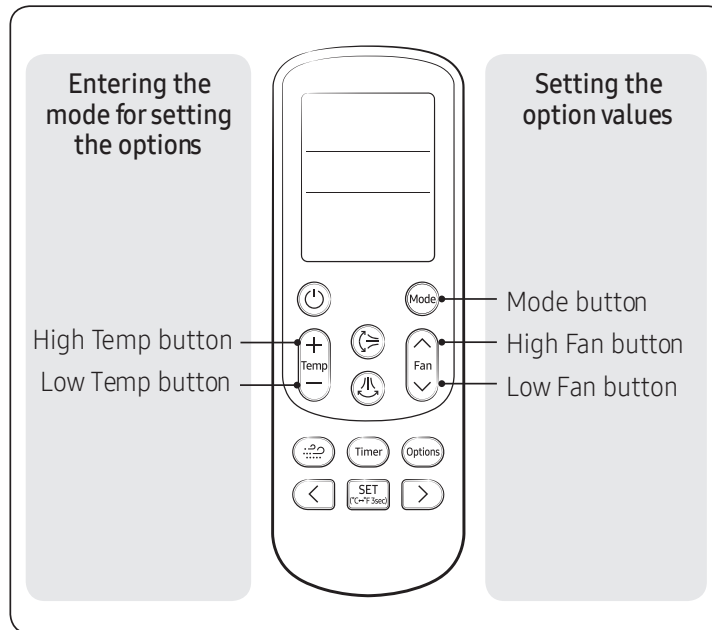

Step 1 Entering mode for option setting.

1. Remove batteries from the remote controller.
2. Insert the batteries while you press [+ Temperature] and [- Temperature] button at the same time.
3. Check if you have entered the option setting status. 



Step 2 Option setting procedure. (The option setting procedure is the same for other models.)

After entering the option setting status, select the option as listed below.



- Option setting is available from SEG1 to SEG24.
- SEG1, SEG7, SEG13, SEG19 are not set as page option.
- Set the SEG2~SEG6, SEG8~SEG12 in the ON status and SEG14~18, SEG20~24 in the OFF status.







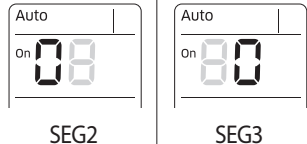
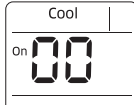
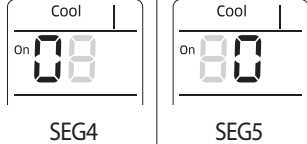
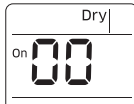
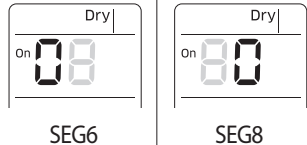
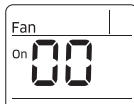
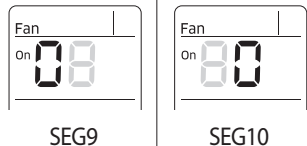
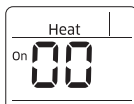
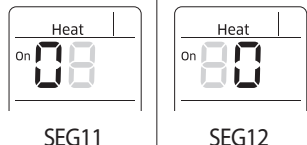
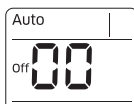
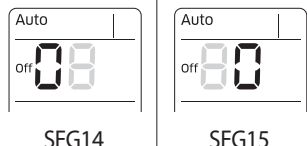



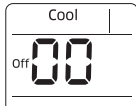



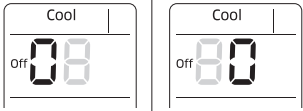

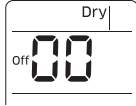



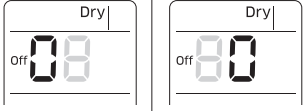

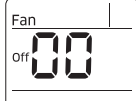
SEG1	SEG2	SEG3	SEG4	SEG5	SEG6	SEG7	SEG8	SEG9	SEG10	SEG11	SEG12
0	X	X	X	X	X	1	X	X	X	X	X
SEG13	SEG14	SEG15	SEG16	SEG17	SEG18	SEG19	SEG20	SEG21	SEG22	SEG23	SEG24
2	X	X	X	X	X	3	X	X	X	X	X

On(SEG1~12)	Off(SEG13~24)
	

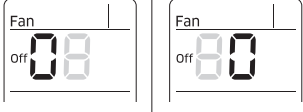
4-1-2 The procedure of setting option

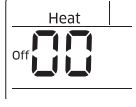
Option setting	Status
<p>1. Setting SEG2, SEG3 option Press Low Fan button(∨) to enter SEG2 value . Press High Fan button(∧) to enter SEG3 value . Each time you press the button, → → ... → will be selected in rotation .</p>	
<p>2. Setting Cool mode Press Mode button to be changed to Cool mode in the ON status .</p>	
<p>3. Setting SEG4, SEG5 option Press Low Fan button(∨) to enter SEG4 value . Press High Fan button(∧) to enter SEG5 value . Each time you press the button, → → ... → will be selected in rotation .</p>	
<p>4. Setting Dry mode Press Mode button to be changed to DRY mode in the ON status .</p>	
<p>5. Setting SEG6, SEG8 option Press Low Fan button(∨) to enter SEG6 value . Press High Fan button(∧) to enter SEG8 value . Each time you press the button, → → ... → will be selected in rotation .</p>	
<p>6. Setting Fan mode Press Mode button to be changed to FAN mode in the ON status .</p>	
<p>7. Setting SEG9, SEG10 option Press Low Fan button(∨) to enter SEG9 value . Press High Fan button(∧) to enter SEG10 value . Each time you press the button, → → ... → will be selected in rotation .</p>	
<p>8. Setting Heat mode Press Mode button to be changed to HEAT mode in the ON status .</p>	
<p>9. Setting SEG11, SEG12 option Press Low Fan button(∨) to enter SEG11 value . Press High Fan button(∧) to enter SEG12 value . Each time you press the button, → → ... → will be selected in rotation .</p>	
<p>10. Setting Auto mode Press Mode button to be changed to AUTO mode in the OFF status.</p>	
<p>11. Setting SEG14, SEG15 option Press Low Fan button(∨) to enter SEG14 value . Press High Fan button(∧) to enter SEG15 value . Each time you press the button, → → ... → will be selected in rotation.</p>	

The procedure of setting option (cont.)

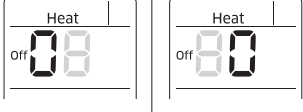
Option setting	Status
<p>12. Setting Cool mode</p> <p> Press Mode button to be change to Cool mode in the OFF status.</p>	
<p>13. Setting SEG16, SEG17 option</p> <p>Press Low Fan button(∨) to enter SEG16 value.</p> <p>Press High Fan button(∧) to enter SEG17 value.</p> <p>Each time you press the button,  →  → ...  →  will be selected in rotation.</p>	
<p>14. Setting Dry mode</p> <p> Press Mode button to be change to Dry mode in the OFF status.</p>	
<p>15. Setting SEG18, SEG20 option</p> <p>Press Low Fan button(∨) to enter SEG18 value.</p> <p>Press High Fan button(∧) to enter SEG20 value.</p> <p>Each time you press the button,  →  → ...  →  will be selected in rotation.</p>	
<p>16. Setting Fan mode</p> <p> Press Mode button to be change to Fan mode in the OFF status.</p>	
<p>17. Setting SEG21, SEG22 option</p> <p>Press Low Fan button(∨) to enter SEG21 value.</p> <p>Press High Fan button(∧) to enter SEG22 value.</p> <p>Each time you press the button,  →  → ...  →  will be selected in rotation.</p>	
<p>18. Setting Heat mode</p> <p> Press Mode button to be change to HEAT mode in the OFF status.</p>	
<p>19. Setting SEG23, SEG24 mode</p> <p>Press Low Fan button(∨) to enter SEG23 value.</p> <p>Press High Fan button(∧) to enter SEG24 value.</p> <p>Each time you press the button,  →  → ...  →  will be selected in rotation.</p>	

Step 3 Check the option you have set

After setting option, press  button to check whether the option code you input is correct or not.

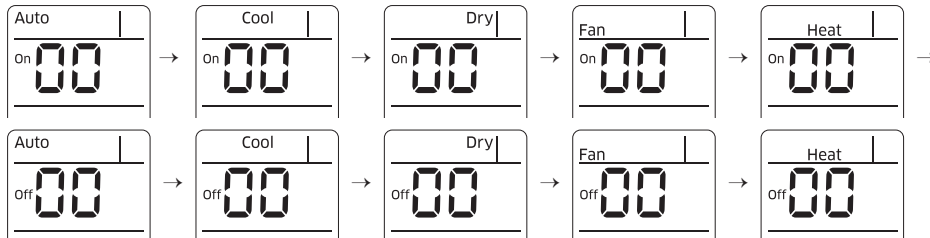

Step 4 Input option

Press the operation button  with the direction of remote control for set.

For the correct option setting, you must input the option twice.

Step 5 Check operation

- 1) Reset the indoor unit by pressing the RESET button of indoor unit or outdoor unit.
- 2) Take the batteries out of the remote controller and insert them again and then press the operation button.

4-1-3 Order for Setting Options (Wired Remote Controller)

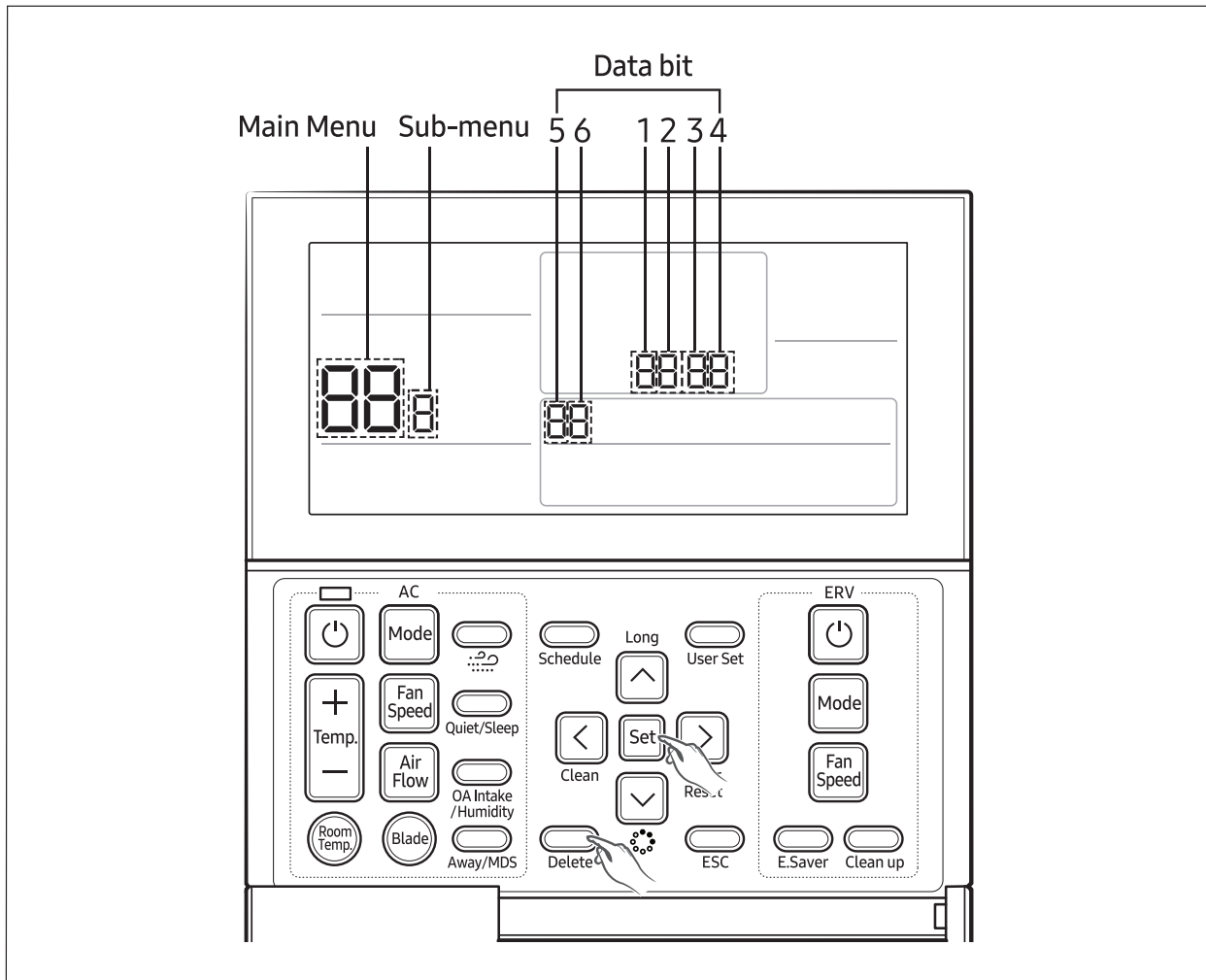

1. If you want to use the various additional functions for your Wired Remote Controller, press the set and delete buttons at the same time for more than three seconds.
 - ▶ You will enter the additional function settings, and the [main menu] will be displayed.
2. Refer to the list of additional functions for your Wired Remote Controller on the next page, and select the desired menu.
 - ▶ Using the [^]/[v] buttons, select a main menu number and press the [>] button to enter the sub-menu setting screen.
 - ▶ Using the [^]/[v] buttons, select a sub-menu number and press the [>] button to enter data setting screen.
 - ▶ When you enter the setting stage, the current setting will be displayed.
 - ▶ Refer to the chart for data settings.
 - ▶ Using the [^]/[v] buttons, select the settings. Press the [>] button to move to the next setting.
 - ▶ Press the **Set** button to save the settings and exit to the sub-menu setting screen.
 - ▶ Press the **Esc** button to exit to normal mode.



- While setting the data, you can use the [<]/[>] buttons to set the range of Data bit.
- While configuring the setting, press the **Esc** button to exit to the setting sub-menu without saving your changes.

4-1-4. Setting the indoor unit addresses

Before installing an indoor unit, be sure to set an address for the indoor unit by taking the following steps:

1. Make sure that the power is supplied to the indoor unit. If the indoor unit is not plugged in, it must include a power supply.
2. Set an address for each indoor unit using the remote control, according to your air conditioning system plan, by referring to the following table and by following the steps in Common steps for setting the addresses and options on page 4-1.
 - The indoor unit addresses (main and RMC addresses) are set to 0A0000-100000-200000-300000 by default.
 - If indoor units and outdoor units match 1:1, you don't need to set the main address because it is automatically set by the outdoor unit.
 - If you are using on or off controller, set RMC address.

Option No. for an indoor unit: 0AXXXX-1XXXXX-2XXXXX-3XXXXX

Option	SEG1		SEG2		SEG3		SEG4		SEG5		SEG6	
Explanation	Page		Mode		Setting main address		100-digit of indoor unit address		10-digit of indoor unit		A single digit of indoor unit	
Indication and details	Indication	Details	Indication	Details	Indication	Details	Indication	Details	Indication	Details	Indication	Details
		0		A		0	No main address	0~9	100-digit	0~9	10-digit	0~9
					1	Main address setting mode						
Option	SEG7		SEG8		SEG9		SEG10		SEG11		SEG12	
Explanation	Page		Reserved		Setting RMC address		Reserved		Group channel (*16)		Group address	
Indication and details	Indication	Details			Indication	Details			Indication	Details	Indication	Details
		1				0	No RMC address			RMC1	1~F	RMC2
					1	RMC address setting mode						



- The main address must be set to a value in the range 0 to 15. If you set other values, communication error will occur.
- If any of SEG5 and SEG6 is set to a value in the range A to F, the main address of the indoor unit does not change.
- If SEG3 is set to 0, the indoor unit maintains the existing main address even if SEG6 is set to a new value.
- If SEG9 is set 0, the indoor unit maintains the existing RMC address even if SEG11 and SET12 are set to new values.

4-1-5. Setting an indoor unit installation option (Suitable for the condition of each installation location)

1. Make sure that the power is supplied to the indoor unit.
If the indoor unit is not plugged in, it must include a power supply.
2. The panel(display) should be connected to an indoor unit to receive option.
※ In the case of Duct indoor unit, Receiver & Display Unit (MRK-A10N) or wired remote control must be connected.
3. Set the functional options of indoor units, by referring to the following table and by following the steps in Common steps for setting the addresses and options on page 4-1.
 - The SEG20 option, Individual control with remotecontrol, allows you to control multiple indoor units individually by using the remote control.

■ 1Way CST, 4Way CST: AC***RN1DKG, AC***RN4DKG

- The installation options of indoor units are set to like a below table by default.

Model	AC026RN1DKG	AC035RN1DKG	AC***RN4DKG
Installation option	020000-100041-200000-300000	020000-100051-200000-300000	020000-100001-200000-300000

Option No. for an indoor unit: 02XXXX-1XXXXX-2XXXXX-3XXXXX

Option	SEG1		SEG2		SEG3	SEG4		SEG5		SEG6	
Function	Page		Mode		Reserved	Use of external temperature sensor		Use of central control		Compensation of the fan RPM	
Indication and details	Indication	Details	Indication	Details		Indication	Details	Indication	Details	Indication	Details
	0		2			0	Disuse	0	Disuse	0	Disuse (recessed installation)
					1	Use	1	Use	1	RPM compensation	
Option	SEG7		SEG8		SEG9	SEG10		SEG11		SEG12	
Function	Page		Use of drain pump		Reserved	Reserved		Reserved		Dew removal operation in WindFree mode	
Indication and details	Indication	Details	Indication	Details						Indication	Details
	1		0	Disuse						0	Maintain blade status in WindFree mode
			1	Use	1	(Default) Cooling operation by opening the blade					
			2	Use with 3 minute delay							

Option	SEG13		SEG14		SEG15		SEG16		SEG17		SEG18			
Function	Page		Use of external control		Setting the output of external control		S-Plasma ion		Buzzer control		Maximum filter usage time			
Indication and details	Indication	Details	Indication	Details	Indication	Details	Indication	Details	Indication	Details	Indication	Details		
	2			0	Disuse	0	Thermo On	0	Disuse	0	Use of buzzer	2	1000 hours	
				1	On/Off									Sub, Existing Control
				2	Off									
				3	Window									
				4	Disuse									Main, Existing Control
				5	On/Off									
				6	Off									
				7	Window									
				8	Disuse	Sub, Reverse Control	1	Operation On	1	Use	1	Disuse of buzzer	6	2000 hours
				9	On/Off									
				A	Off									
				B	Window									
				C	Disuse	Main, Reverse Control								
				D	On/Off									
				E	Off									
F				Window										

Option	SEG19		SEG20		SEG21		SEG22		SEG23		SEG24	
Function	Page		Individual control with remote control		Heating setting compensation		Reserved		Reserved		Cycle time of Swing	
Indication and details	Indication	Details	Indication	Details	Indication	Details					Indication	Details
	3			0 or 1	Indoor 1	0					Default	0
				2	Indoor 2	1	2°C	1	30 seconds			
				3	Indoor 3	2	5°C					
4				Indoor 4								

• **SEG8)**
Even if you set the Use of drain pump option to 0, it is automatically set to 2 (the drain pump is used with 3 minute delay).

• **SEG14)**
Example: When installing DPM (1 Outdoor unit with 4 indoor units)

Condition		SEG14 Setting				Result
External control	Level control *	Indoor1	Indoor2	Indoor 3	Indoor 4	
Default		Not set (0)				Sub (All)
Disuse	Use	4	Not set (0)	Not set (0)	Not set (0)	Main (Indoor1), Sub (Indoor 2,3,4)
Use (Indoor 3)	Disuse	Not set (0)	Not set (0)	1~3	Not set (0)	Sub (All)
Use (Indoor 4)	Use	Not set (0)	Not set (0)	Not set (0)	5~7	Main (Indoor 4), Sub (Indoor1,2,3)

* Level control: The centralized controller can limit the functions and inputs of connected products with this function enabled. (Example: Operation mode limit (Cooling only/Heating only/No limitation), Heating temperature upper limit, Cooling temperature lower limit) To enable 'Level control' when applying the DPM with the centralized controller, appoint the 'Main'. (Set 'Use of external control [SEG14] option to a value of 4 to 7 or C to F.)

• **SEG18)**
If you set the Maximum filter usage time option to a value other than 2 and 6, it is automatically set to 2 (1000 hours).

• **SEG20)**
If you set the Individual control with remote control (SEG20) option to a value other than 0 to 4, it is automatically set to 0 (Indoor1).

• **SEG21)**
The default value of the heating setting compensation (SEG21) is as follows.

AC***RN1DKG	AC***RN4DKG
2°C	5°C

■ Mini4way CST: AC***RNNDKG

- The installation options of indoor units are set to like a below table by default.

Model	AC026RNNDKG AC035RNNDKG AC052RNNDKG	AC071RNNDKG
Installation option	020000-100001-200000-300000	020000-100031-200000-300000

Option No. for an indoor unit: 02XXXX-1XXXXX-2XXXXX-3XXXXX

Option	SEG1		SEG2		SEG3	SEG4		SEG5			SEG6		
Function	Page		Mode		Reserved	Use of external temperature sensor		Use of central control			Compensation of the fan RPM		
Indication and details	Indication	Details	Indication	Details		Indication	Details	Indication	Details		Indication	Details	
	0		2			0	Disuse	0	Disuse		0	Disuse	
					1	Use	1	Use		1	High ceiling mode		
Option	SEG7		SEG8		SEG9	SEG10		SEG11			SEG12		
Function	Page		Use of drain pump		Reserved	Reserved		Compensation of the wind-free fan RPM			Dew removal operation in Wind-Free mode		
Indication and details	Indication	Details	Indication	Details				Indication	Details		Indication	Details	
	1		0	Disuse				Model	AC026RNNDKG AC035RNNDKG AC052RNNDKG	AC071RNNDKG	0	Maintain blade status in Wind-Free mode	
			1	Use							1	(Default) Cooling operation by opening the blade	
			2	Use with 3 minute delay									0
3	3 step ↓	Default											
Option	SEG13		SEG14		SEG15		SEG16		SEG17		SEG18		
Function	Page		Use of external control		Setting the output of external control		S-Plasma ion		Buzzer control		Maximum filter usage time		
Indication and details	Indication	Details	Indication	Details	Indication	Details	Indication	Details	Indication	Details	Indication	Details	
	2		0	Disuse	0	Thermo On	0	Disuse	0	Use of buzzer	2	1000 hours	
			1	On/Off									Sub, Existing Control
			2	Off									
			3	Window									Main, Existing Control
			4	Disuse									
			5	On/Off									
			6	Off									
	7	Window											
	8	Disuse	1	Operation On	1	Use	1	Disuse of buzzer	6	2000 hours			
	9	On/Off									Sub, Reverse Control		
	A	Off											
	B	Window	Main, Reverse Control										
	C	Disuse											
D	On/Off												
E	Off												
F	Window												

Troubleshooting

Option	SEG19		SEG20		SEG21		SEG22	SEG23	SEG24	
Function	Page		Individual control with remote control		Heating setting compensation		Reserved	Reserved	Reserved	
Indication and details	Indication	Details	Indication	Details	Indication	Details				
	3			1	Indoor1	0				0°C (default)
				2	Indoor2	1				2°C
				3	Indoor3	2	5°C			
			4	Indoor4						

- **SEG8)**
Even if you set the Use of drain pump option to 0, it is automatically set to 2 (the drain pump is used with 3 minute delay).
- **SEG11)**
Each model's compensation of the wind-free fan RPM (SEG11) option has to be set by default.
Compensation of the wind-free fan RPM (SEG11) option adjusts 20 rpm per 1 step.
- **SEG14)**
Example: When installing DPM (1 Outdoor unit with 4 indoor units)

Condition		SEG14 Setting				Result
External control	Level control *	Indoor1	Indoor2	Indoor3	Indoor4	
Default		Not set (0)				Sub (All)
Disuse	Use	4	Not set (0)	Not set (0)	Not set (0)	Main (Indoor1), Sub (Indoor 2,3,4)
Use (Indoor 3)	Disuse	Not set (0)	Not set (0)	1-3	Not set (0)	Sub (All)
Use (Indoor 4)	Use	Not set (0)	Not set (0)	Not set (0)	5-7	Main (Indoor 4), Sub (Indoor 1,2,3)

* Level control: The centralized controller can limit the functions and inputs of connected products with this function enabled. (Example: Operation mode limit (Cooling only/Heating only/No limitation), Heating temperature upper limit, Cooling temperature lower limit) To enable 'Level control' when applying the DPM with the centralized controller, appoint the 'Main'. (Set 'Use of external control [SEG14] option to a value of 4 to 7 or C to F.)

- **SEG18)**
If you set the Maximum filter usage time option to a value other than 2 and 6, it is automatically set to 2 (1000 hours).
- **SEG20)**
If you set the Individual control with remote control (SEG20) option to a value other than 0 to 4, it is automatically set to 0 (Indoor1).
- **SEG21)**
Default value of Heating setting compensation (SEG21) is 5°C.

■ 360 CST: AC***RN4PKG

- The default setting of an indoor unit installation option is 020000-100000-200000-300000.

Option No. for an indoor unit: 02XXXX-1XXXXX-2XXXXX-3XXXXX

Option	SEG1		SEG2		SEG3		SEG4		SEG5		SEG6		
Function	Page		Mode		Reserved		Use of external temperature sensor		Use of central control		Compensation of the fan RPM		
Indication and details	Indication	Details	Indication	Details			Indication	Details	Indication	Details	Indication	Details	
	0			2		0	Disuse	0	Disuse	0	Disuse	0	Disuse (recessed installation)
												1	High-ceiling mode (recessed installation)
												4	Disuse (exposed installation)
5												High-ceiling mode (exposed installation)	
Option	SEG7		SEG8		SEG9		SEG10		SEG11		SEG12		
Function	Page		Use of drain pump		Reserved		Reserved		Reserved		Reserved		
Indication and details	Indication	Details	Indication	Details									
	1		0	Disuse									
			1	Use									
			2	Use with 3 minute delay									
Option	SEG13		SEG14		SEG15		SEG16		SEG17		SEG18		
Function	Page		Use of external control		Setting the output of external control		S-Plasma ion		Buzzer control		Maximum filter usage time		
Indication and details	Indication	Details	Indication	Details	Indication	Details	Indication	Details	Indication	Details	Indication	Details	
	2		0	Disuse	0	Thermo On	0	Disuse	0	Use of buzzer	2	1000 hours	
			1	On/Off									Sub, Existing Control
			2	Off									
			3	Window									
			4	Disuse	Main, Existing Control								
			5	On/Off									
			6	Off									
			7	Window									
	8	Disuse	1	Operation On	1	Use	1	Disuse of buzzer	6	2000 hours			
	9	On/Off									Sub, Reverse Control		
	A	Off											
	B	Window											
	C	Disuse	Main, Reverse Control										
	D	On/Off											
	E	Off											
F	Window												

Option	SEG19		SEG20		SEG21		SEG22
Function	Page		Individual control with remote control		Heating setting compensation		Reserved
Indication and details	Indication	Details	Indication	Details	Indication	Details	
	3		0 or 1	Indoor 1	0	Default	
			2	Indoor 2	1	2°C	
			3	Indoor 3	2	5°C	
		4	Indoor 4				
Option	SEG23				SEG24		
Function	Setting the MDS Kit installation option				Cycle time of Swing		
Indication and details	Indication		Details		Indication	Details	
	0		Disuse (Soft Off+Hard off)		0	34 seconds (default)	
	Standard	1	Off after 20 min. (Soft Off+Hard off)				
		2	Off after 40 min. (Soft Off+Hard off)				
		3	Off after 80 min. (Soft Off+Hard off)				
	Premium	4	Off after 20 min. (Soft Off+Hard off)		1	30 seconds	
		5	Off after 40 min. (Soft Off+Hard off)				
		6	Off after 80 min. (Soft Off+Hard off)				
	Standard	7	Off after 20 min. (Soft Off only)				
		8	Off after 40 min. (Soft Off only)				
		9	Off after 80 min. (Soft Off only)				
	Premium	A	Off after 20 min. (Soft Off only)		2	38 seconds	
		B	Off after 40 min. (Soft Off only)				
		C	Off after 80 min. (Soft Off only)				

- **SEG8)**
Even if you set the Use of drain pump option to 0, it is automatically set to 2 (the drain pump is used with 3 minute delay).
- **SEG14)**
Example: When installing DPM (1 Outdoor unit with 4 indoor units)

Condition		SEG14 Setting				Result
External control	Level control *	Indoor1	Indoor 2	Indoor 3	Indoor 4	
Default		Not set (0)				Sub (All)
Disuse	Use	4	Not set (0)	Not set (0)	Not set (0)	Main (Indoor1), Sub (Indoor 2,3,4)
Use (Indoor 3)	Disuse	Not set (0)	Not set (0)	1~3	Not set (0)	Sub (All)
Use (Indoor 4)	Use	Not set (0)	Not set (0)	Not set (0)	5~7	Main (Indoor 4), Sub (Indoor 1,2,3)

* Level control: The centralized controller can limit the functions and inputs of connected products with this function enabled. (Example: Operation mode limit (Cooling only/Heating only/No limitation), Heating temperature upper limit, Cooling temperature lower limit) To enable 'Level control' when applying the DPM with the centralized controller, appoint the 'Main'. (Set 'Use of external control [SEG14] option to a value of 4 to 7 or C to F.)

- **SEG18)**
If you set the Maximum filter usage time option to a value other than 2 and 6, it is automatically set to 2 (1000 hours).
- **SEG20)**
If you set the Individual control with remote control (SEG20) option to a value other than 0 to 4, it is automatically set to 0 (Indoor1).
- **SEG21)**
Default value of Heating setting compensation (SEG21) is 5°C.
- **SEG23)**
SOFT OFF: The indoor unit turns off its operation at the indicated time in the table for Installation Option after its final motion detection. But, it turns on again if the MDS detects motion.
HARD OFF: Designated time after SOFT OFF, it cannot turn on automatically when it detects motion. Users should control to turn on the indoor unit with remote control, etc.

■ Duct: AC***RNLDKG, AC***RNMDKG

- The default setting of an indoor unit installation option is 020000-100000-200000-300000.

Option No. for an indoor unit: 02XXXX-1XXXXX-2XXXXX-3XXXXX

Option	SEG1		SEG2		SEG3			SEG4		
Explanation	PAGE		MODE		RESERVED			Use of external temperature sensor		
Indication and Details	Indication	Details	Indication	Details				Indication	Details	
	0		2					0	Disuse	1
Option	SEG5		SEG6		SEG7			SEG8		
Explanation	Use of central control		RESERVED		PAGE			Use of drain pump		
Indication and Details	Indication	Details			Indication		Details		Indication	Details
	0	Disuse			1		1		0	Disuse
	1	Use	1	Use					2	Use + 3minute delay
Option	SEG9		SEG10		SEG11			SEG12		
Explanation	Use of Hot Coil		Use of heater		Controller variables for auxiliary heater			RESERVED		
Indication and Details	0	Disuse	0	Disuse	Indication	Details				
						Set temperature for auxiliary heat on	Time delay for auxiliary heat on			
						0	No temperature offset			No delay
	1	Use	1	Use	1	No temperature offset	10 minutes			
					2	No temperature offset	20 minutes			
					3	1.5°C	No delay			
					4	1.5°C	10 minutes			
					5	1.5°C	20 minutes			
					6	3°C	No delay			
					7	3°C	10 minutes			
	-	-	2	Use (Heater time delay)	8	3°C	20 minutes			
					9	4.5°C	No delay			
					A	4.5°C	10 minutes			
B					4.5°C	20 minutes				
-	-	2	Use (Heater time delay)	C	6°C	No delay				
				D	6°C	10 minutes				
				E	6°C	20 minutes				

Option	SEG13		SEG14			SEG15		SEG16					
Explanation	Page		Use of external control			Setting the output of external control		S-Plasma ion					
Indication and details	Indication	Details	Indication	Details		0	Thermo On	0	Disuse				
		2	0	Disuse	Sub, Existing Control					1	Operation On	1	Use
			1	On/Off									
			2	Off									
			3	Window	Main, Existing Control								
			4	Disuse									
			5	On/Off									
			6	Off	Sub, Reverse Control								
			7	Window									
			8	Disuse									
			9	On/Off	Main, Reverse Control								
			A	Off									
			B	Window									
			C	Disuse									
			D	On/Off	Main, Reverse Control								
	E		Off										
	F	Window											

Option	SEG17		SEG18		SEG19		SEG20		
Explanation	Buzzer control		Number of hours using filter		Page		Individual control with remote control		
Indication and details	Indication	Details	Indication	Details	3	0 or 1	Indoor 1		
	0	Use of buzzer	2	1000 hours				2	Indoor 2
	1	Non use of buzzer	6	2000 hours					
								4	Indoor 4

Option	SEG21		SEG22		SEG23		-
Explanation	Heating setting compensation		Reserved		Away Set OFF Timer		-
Indication and details	Indication	Details			Indication	Details	-
	0	Default			0 or 1	Auto Set OFF 30Min.	-
	1	2°C			2	Auto Set OFF 60Min.	
	2	5°C			3	Auto Set OFF 120Min.	
4			Auto Set OFF 180Min.				

• **SEG14)**
 Example: When installing DPM (1 Outdoor unit with 4 indoor units)

Condition		SEG14 Setting				Result
External control	Level control *	Indoor 1	Indoor 2	Indoor 3	Indoor 4	
Default		Not set (0)				Sub (All)
Disuse	Use	4	Not set (0)	Not set (0)	Not set (0)	Main (Indoor 1), Sub (Indoor 2,3,4)
Use (Indoor 3)	Disuse	Not set (0)	Not set (0)	1~3	Not set (0)	Sub (All)
Use (Indoor 4)	Use	Not set (0)	Not set (0)	Not set (0)	5~7	Main (Indoor 4), Sub (Indoor 1,2,3)

* Level control: The centralized controller can limit the functions and inputs of connected products with this function enabled. (Example: Operation mode limit (Cooling only/Heating only/No limitation), Heating temperature upper limit, Cooling temperature lower limit) To enable 'Level control' when applying the DPM with the centralized controller, appoint the 'Main'. (Set 'Use of external control [SEG14] option to a value of 4 to 7 or C to F)

• **SEG21)**
 Default value of Heating setting compensation (SEG21) is 2°C.

■ C-RAC: AC***RNADKG, AC***RNTDKG

- The installation options of indoor units are set to like a below table by default.

Model	AC026RNADKG AC035RNADKG AC052RNADKG AC071RNADKG	AC100RNTDKG
Installation option	020000-100000-200100-300000	020000-100000-200000-300000

Option No. for an indoor unit: 02XXXX-1XXXXX-2XXXXX-3XXXXX

Option	SEG1		SEG2		SEG3	SEG4		SEG5		SEG6			
Explanation	PAGE		MODE		RESERVED	Use of external temperature sensor		Use of central control		RESERVED			
Indication and details	Indication	Details	Indication	Details		Indication	Details	Indication	Details				
	0		2			0	Disuse	0	Disuse				
					1	Use	1	Use					
Option	SEG7		SEG8		SEG9	SEG10		SEG11		SEG12			
Explanation	PAGE		Use of drain pump		RESERVED	RESERVED		RESERVED		RESERVED			
Indication and details	Indication	Details	Indication	Details									
	1		0	Disuse									
			1	Use									
			2	Use + 3 minute delay									
Option	SEG13		SEG14		SEG15		SEG16		SEG17		SEG18		
Explanation	PAGE		Use of external control		Setting the output of external control		S-Plasma ion		Buzzer control		Maximum filter usage time		
Indication and details	Indication	Details	Indication	Details	0	Thermo on	0	Disuse	0	Use	2	1000 hours	
	2		0	Disuse									Sub, Existing Control
			1	On/Off									
			2	Off									
			3	Window									
			4	Disuse	Main, Existing Control								
			5	On/Off									
			6	Off									
			7	Window									
			8	Disuse	Sub, Reverse Control								
			9	On/Off									
			A	Off									
			B	Window	Main, Reverse Control								
			C	Disuse									
			D	On/Off									
E			Off										
		F	Window	1	Operation on	1	Use	1	Disuse	6	2000 hours		

Option	SEG19		SEG20		SEG21		SEG22	SEG23	SEG24
Function	Page		Individual control with remote control		Heating setting compensation		Reserved	Reserved	Reserved
Indication and details	Indication	Details	Indication	Details	Indication	Details			
	3		1	Indoor1	0	Default			
			2	Indoor2	1	2°C			
			3	Indoor3	2	5°C			
4			Indoor4						

• **SEG14)**

Example: When installing DPM (1 Outdoor unit with 4 indoor units)

Condition		SEG14 Setting				Result
External control	Level control *	Indoor1	Indoor2	Indoor3	Indoor4	
Default		Not set (0)				Sub (All)
Disuse	Use	4	Not set (0)	Not set (0)	Not set (0)	Main (Indoor1), Sub (Indoor 2,3,4)
Use (Indoor 3)	Disuse	Not set (0)	Not set (0)	1~3	Not set (0)	Sub (All)
Use (Indoor 4)	Use	Not set (0)	Not set (0)	Not set (0)	5~7	Main (Indoor 4), Sub (Indoor1,2,3)

* Level control: The centralized controller can limit the functions and inputs of connected products with this function enabled. (Example: Operation mode limit (Cooling only/Heating only/No limitation), Heating temperature upper limit, Cooling temperature lower limit) To enable 'Level control' when applying the DPM with the centralized controller, appoint the 'Main'. (Set 'Use of external control [SEG14] option to a value of 4 to 7 or C to F.)

• **SEG18)**

If you set the Maximum filter usage time option to a value other than 2 and 6, it is automatically set to 2 (1000 hours).

• **SEG20)**

If you set the Individual control with remote control (SEG20) option to a value other than 0 to 4, it is automatically set to 0 (Indoor1).

• **SEG21)**

Default value of Heating setting compensation (SEG21) is 5°C.

■ Ceiling: AC***RNCDKG

- The default setting of an indoor unit installation option is 020000-100000-200000-300000.

Option No. for an indoor unit: 02XXXX-1XXXXX-2XXXXX-3XXXXX

Option	SEG1		SEG2		SEG3		SEG4		SEG5		SEG6		
Explanation	PAGE		MODE		RESERVED		Use of external temperature sensor		Use of central control		RESERVED		
Indication and Details	Indication	Details	Indication	Details			Indication	Details	Indication	Details			
	0		2				0	Disuse	0	Disuse			
					1	Use	1	Use					
Option	SEG7		SEG8		SEG9		SEG10		SEG11		SEG12		
Explanation	PAGE		RESERVED		RESERVED		RESERVED		RESERVED		RESERVED		
Indication and Details	Indication	Details											
	1												
Option	SEG13		SEG14		SEG15		SEG16		SEG17		SEG18		
Explanation	PAGE		Use of external control		Setting the output of external control		S-Plasma ion		Buzzer control		Number of hours using filter		
Indication and Details	Indication	Details	Indication	Details	0	Thermo on	0	Disuse	0	Use of buzzer	2	1000 Hour	
	2		0	Disuse									Sub, Existing Control
			1	On/Off									
			2	Off									
			3	Window									
			4	Disuse									Main, Existing Control
			5	On/Off									
			6	Off									
		7	Window										
		8	Disuse	Sub, Reverse Control									
		9	On/Off										
		A	Off										
		B	Window										
		C	Disuse	Main, Reverse Control									
		D	On/Off										
		E	Off										
		F	Window										
				1	Operation on	1	Use	1	Non use of buzzer	6	2000 Hour		

Option	SEG19		SEG20		SEG21		SEG22	SEG23	SEG24
Explanation	PAGE		Individual control of a remote controller		Heating setting compensation				
Indication and Details	Indication	Details	Indication	Details	Indication	Details	RESERVED	RESERVED	RESERVED
	3		0 or 1	Indoor 1	0	Default			
			1		1	2 °C			
			2	Indoor 2	2	5 °C			
			3	Indoor 3					
4	Indoor 4								

• **SEG14)**

Example: When installing DPM (1 Outdoor unit with 4 indoor units)

Condition		SEG14 Setting				Result
External control	Level control *	Indoor 1	Indoor 2	Indoor 3	Indoor 4	
Default		Not set (0)				Sub (All)
Disuse	Use	4	Not set (0)	Not set (0)	Not set (0)	Main (Indoor 1), Sub (Indoor 2,3,4)
Use (Indoor 3)	Disuse	Not set (0)	Not set (0)	1~3	Not set (0)	Sub (All)
Use (Indoor 4)	Use	Not set (0)	Not set (0)	Not set (0)	5~7	Main (Indoor 4), Sub (Indoor 1,2,3)

* Level control: The centralized controller can limit the functions and inputs of connected products with this function enabled. (Example: Operation mode limit (Cooling only/Heating only/No limitation), Heating temperature upper limit, Cooling temperature lower limit) To enable 'Level control' when applying the DPM with the centralized controller, appoint the 'Main'. (Set 'Use of external control [SEG14] option to a value of 4 to 7 or C to F.)

• **SEG20)**

If you set the Individual control with remote control (SEG20) option to a value other than 0 to 4, it is automatically set to 0 (Indoor 1).

• **SEG21)**

The default value of the heating setting compensation (SEG21) is as follows.

AC052/071RNCCKG	AC100/120/140RN4DKG
5°C	2°C

■ Console: AC***RNJDKG

- The default setting of an indoor unit installation option is 020000-100000-200100-300000.

Option No. for an indoor unit: 02XXXX-1XXXX-2XXXX-3XXXX

Option	SEG1		SEG2		SEG3	SEG4		SEG5		SEG6			
Explanation	PAGE		MODE		RESERVED	Use of external temperature sensor		Use of central control		RESERVED			
Indication and details	Indication	Details	Indication	Details		Indication	Details	Indication	Details				
	0		2			0	Disuse	0	Disuse				
					1	Use	1	Use					
Option	SEG7		SEG8		SEG9	SEG10		SEG11		SEG12			
Explanation	PAGE		RESERVED		RESERVED	RESERVED		RESERVED		RESERVED			
Indication and details	Indication	Details											
	1												
Option	SEG13		SEG14		SEG15		SEG16		SEG17		SEG18		
Explanation	PAGE		Use of external control		Setting the output of external control		S-Plasma ion		Buzzer control		Maximum filter usage time		
Indication and details	Indication	Details	Indication	Details	0	Thermo on	0	Disuse	0	Use of buzzer	2	1000 Hour	
	2		0	Disuse									Sub, Existing Control
			1	On/Off									
			2	Off									
			3	Window									
	2		4	Disuse	Main, Existing Control								
			5	On/Off									
			6	Off									
			7	Window									
	2		8	Disuse	Sub, Reverse Control								
			9	On/Off									
			A	Off									
	2		B	Window	Main, Reverse Control								
			C	Disuse									
			D	On/Off									
2		E	Off										
		F	Window										
				1	Operation on	1	Use	1	Disuse of buzzer	6	2000 Hour		

Troubleshooting

Option	SEG19		SEG20		SEG21		SEG22	SEG23	SEG24
Explanation	PAGE		Individual control of a remote controller		Heating setting compensation		RESERVED	RESERVED	RESERVED
Indication and details	Indication	Details	Indication	Details	Indication	Details			
	3		0 or 1	Indoor 1	0	Default			
			2	Indoor 2					
			3	Indoor 3					
			4	Indoor 4	1	2°C			
				2	5°C				

• **SEG14)**

Example: When installing DPM (1 Outdoor unit with 4 indoor units)

Condition		SEG14 Setting				Result
External control	Level control *	Indoor 1	Indoor 2	Indoor 3	Indoor 4	
Default		Not set (0)				Sub (All)
Disuse	Use	4	Not set (0)	Not set (0)	Not set (0)	Main (Indoor 1), Sub (Indoor 2,3,4)
Use (Indoor 3)	Disuse	Not set (0)	Not set (0)	1~3	Not set (0)	Sub (All)
Use (Indoor 4)	Use	Not set (0)	Not set (0)	Not set (0)	5~7	Main (Indoor 4), Sub (Indoor 1,2,3)

* Level control: The centralized controller can limit the functions and inputs of connected products with this function enabled. (Example: Operation mode limit (Cooling only/Heating only/No limitation), Heating temperature upper limit, Cooling temperature lower limit) To enable 'Level control' when applying the DPM with the centralized controller, appoint the 'Main'. (Set 'Use of external control [SEG14] option to a value of 4 to 7 or C to F.)

• **SEG20)**

If you set the Individual control with remote control (SEG20) option to a value other than 0 to 4, it is automatically set to 0 (Indoor 1).

• **SEG21)**

Default value of Heating setting compensation (SEG21) is 5°C.

4-1-6 Changing a particular option

You can change each digit of set option.

Option	SEG1		SEG2		SEG3		SEG4		SEG5		SEG6	
Explanation	PAGE		MODE		The option mode you want to change		The tens' digit of an option SEG you will change		The unit digit of an option SEG you will change		The changed value	
Indication and Details	Indication	Details	Indication	Details	Indication	Details	Indication	Details	Indication	Details	Indication	Details
	0		D		Option mode	0~F	Tens' digit of SEG	0~9	Unit digit of SEG	0~9	The changed value	0~F



- When changing a digit of an indoor unit address setting option, set the SEG3 as 'A'.
- When changing a digit of indoor unit installation option, set the SEG3 as '2'.

Option	SEG1	SEG2	SEG3	SEG4	SEG5	SEG6
Explanation	PAGE	MODE	The option mode you want to change	The tens' digit of an option SEG you will change	The unit digit of an option SEG you will change	The changed value
Indication	0	D	2	1	7	1

Ex) When setting the 'buzzer control' into disuse status.

4-1-7. Emergency Temperature Output (ETO) function



- In order to deploy the ETO function, the MIM-B14, an external contact interface module, must be installed in each indoor unit.
- The ETO is a concept of emergency operation of indoor units. If the indoor unit 1 (main indoor unit) stops because of an error, the indoor unit 2 (sub indoor unit) starts to operate.
- Basically, the indoor unit 2 operates in the previous mode. [For the first time operation, it starts in 24 °C Auto mode.]
- To set more detailed operation conditions for the indoor unit 2, use the S-net Pro.

■ Setting up the ETO

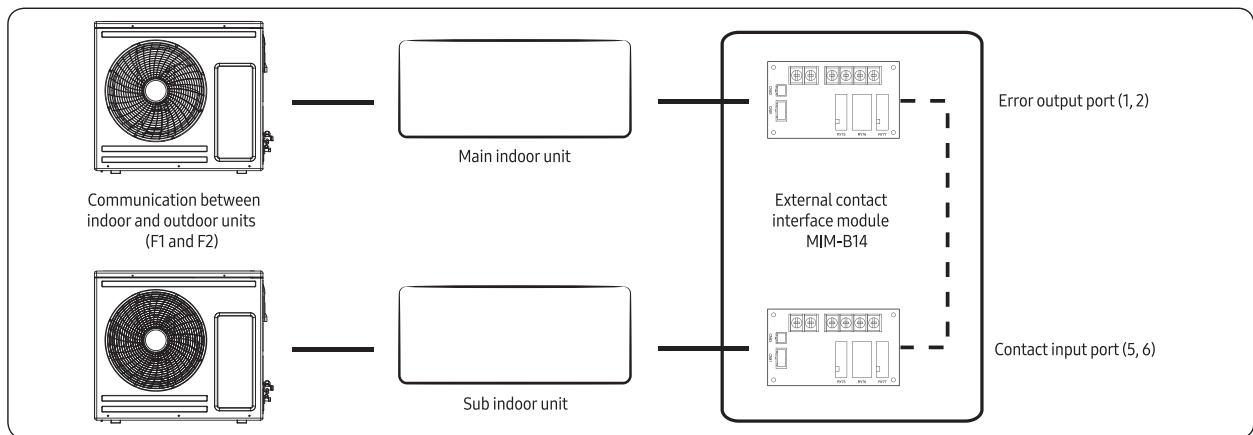

1 Main indoor unit

- Disable the external contact control (Default).
- Connect the S-net pro2 to F1 and F2.
- Enable the ETO function and set the temperature and time.

2 Sub indoor unit

- (Required) Enable the external contact control (with the installation option SEG14 - Reverse Control).
- Connect the S-net pro2 to F1 and F2.
- Enable the entrance control and set the mode, set temperature, and fan speed.

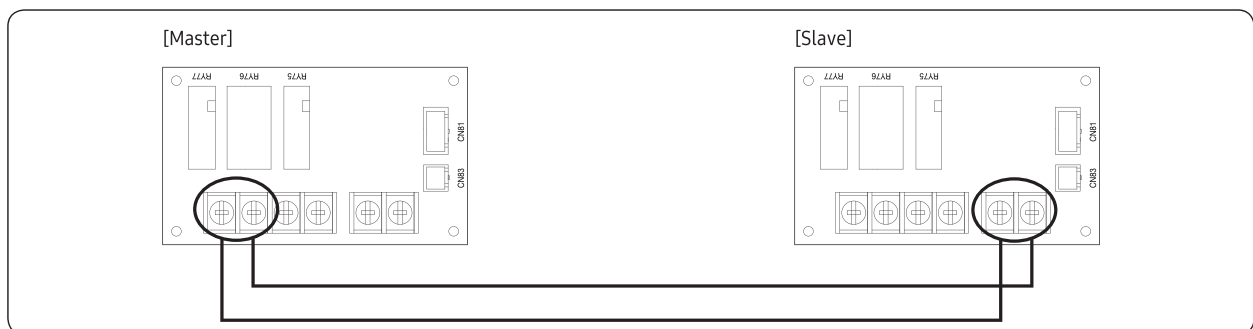

Emergency Temperature Output (ETO) function (Cont.)

■ ETO operation specifications

1 Main indoor unit

- Based on the external contact control settings, the main indoor unit decides whether to generate output when an error (indoor unit stop) occurs.
- Based on the ETO settings, the main indoor unit decides whether to generate output according to the temperature and time conditions.

2 Sub indoor unit

- Based on the entrance control settings, the sub indoor unit decides the mode, set temperature, and fan speed when contact inputs are given.

	Enable of ETO	Enable of external contact	Error port output
Main indoor unit	X	X	N/A
	X	O	Output due to an error
	O	X	Output by ETO entrance conditions (temperature / time / error occurrence)
	O	O	Output by ETO entrance conditions (temperature / time / error occurrence) * Ready to control the main contact input

	Enable of entrance control	Enable of external contact	Operation when outputting Main
Sub indoor unit	X	X	N/A
	X	O	On with the previous operation conditions
	O	O	On with the entrance control enabled

4-1-8 Option code for each model

Item	Model	SEG																								Static Pressure (Only Duct)
		1	2	3	4	5	6	7	8	9	10	11	12	13	14	15	16	17	18	19	20	21	22	23	24	
1Way CST	AC026RN1DKG/EU	0	1	7	1	7	C	1	9	3	0	F	8	2	7	1	A	2	1	3	7	1	1	2	0	
	AC035RN1DKG/EU	0	1	7	1	7	C	1	9	3	4	4	D	2	7	2	3	2	8	3	7	1	1	2	0	
Mini 4way CST	AC026RNNDKG/EU	0	1	5	1	7	F	1	9	1	0	C	8	2	7	1	A	2	2	3	7	0	0	0	0	
	AC035RNNDKG/EU	0	1	5	1	7	F	1	9	3	0	F	9	2	7	2	3	2	8	3	7	0	0	0	0	
	AC052RNNDKG/EU	0	1	5	1	7	F	1	9	3	4	5	D	2	7	3	4	3	C	3	7	0	0	4	0	
	AC071RNNDKG/EU	0	1	5	1	7	F	1	9	4	5	8	1	2	7	4	7	5	0	3	7	0	0	4	0	
4Way CST	AC052RN4DKG/EU	0	1	4	1	7	F	1	9	4	0	A	8	2	7	3	4	3	C	3	7	0	0	0	0	
	AC071RN4DKG/EU	0	1	4	1	7	F	1	9	4	0	C	8	2	7	4	7	5	0	3	7	0	0	0	0	
	AC100RN4DKG/EU	0	1	4	1	7	F	1	9	5	4	2	9	2	7	6	4	7	0	3	7	0	0	4	0	
	AC120RN4DKG/EU	0	1	4	1	7	F	1	9	5	4	3	A	2	7	7	8	8	2	3	7	0	0	4	0	
360 CST	AC140RN4DKG/EU	0	1	4	1	7	F	1	9	5	4	3	B	2	7	8	C	A	0	3	3	0	0	4	0	
	AC071RN4PKG/EU	0	1	0	1	7	F	1	9	4	0	D	8	2	7	4	7	5	0	3	7	0	0	0	0	
	AC100RN4PKG/EU	0	1	0	1	7	F	1	9	5	4	8	C	2	7	6	4	7	0	3	7	0	0	4	0	
	AC120RN4PKG/EU	0	1	0	1	7	F	1	9	5	4	9	D	2	7	7	8	8	2	3	7	0	0	4	0	
Duct	AC026RNLDKG/EU	0	1	C	1	7	C	1	C	1	9	1	4	2	7	1	A	2	1	3	7	0	0	0	0	0≤SP≤2.5
		0	1	C	1	7	C	1	C	1	9	6	9	2	7	1	A	2	1	3	7	0	0	0	0	2.5<SP≤4
	AC035RNLDKG/EU	0	1	C	1	7	C	1	C	3	9	3	6	2	7	2	3	2	8	3	7	0	0	0	0	0≤SP≤2.5
		0	1	C	1	7	C	1	C	3	9	A	D	2	7	2	3	2	8	3	7	0	0	0	0	2.5<SP≤4
AC052RNLDKG/EU	0	1	C	1	7	C	1	C	1	9	2	4	2	7	3	4	3	C	3	7	0	0	0	0	0≤SP≤3	
	0	1	C	1	7	C	1	C	1	9	6	8	2	7	3	4	3	C	3	7	0	0	0	0	3<SP≤4	
AC071RNLDKG/EU	0	1	C	1	7	C	1	C	5	9	D	0	2	7	4	7	5	0	3	7	0	0	0	5	0≤SP≤3	
	0	1	C	1	7	C	1	C	5	D	2	1	2	7	4	7	5	0	3	7	0	0	0	5	3<SP≤4	
AC035RNMDKG/EU	0	1	B	1	7	C	1	C	5	0	8	0	2	7	2	3	2	8	3	7	2	0	0	8	0≤SP≤2.5	
	0	1	B	1	7	C	1	C	5	4	0	7	2	7	2	3	2	8	3	7	2	0	0	8	2.5<SP≤5	
	0	1	B	1	7	C	1	C	5	4	8	C	2	7	2	3	2	8	3	7	2	0	0	8	5<SP≤7.5	
	0	1	B	1	7	C	1	C	5	5	D	3	2	7	2	3	2	8	3	7	2	0	0	8	7.5<SP≤10	
	0	1	B	1	7	C	1	C	5	9	2	6	2	7	2	3	2	8	3	7	2	0	0	8	10<SP≤12.5	
AC052RNMDKG/EU	0	1	B	0	7	C	1	C	5	9	9	8	2	7	2	3	2	8	3	7	2	0	0	8	12.5<SP≤15	
	0	1	B	1	7	C	1	C	5	0	F	1	2	7	3	4	3	C	3	7	4	0	0	0	0≤SP≤3	
	0	1	B	1	7	C	1	C	5	4	8	8	2	7	3	4	3	C	3	7	4	0	0	0	3<SP≤6	
	0	1	B	1	7	C	1	C	5	4	E	D	2	7	3	4	3	C	3	7	4	0	0	0	6<SP≤9	
	0	1	B	1	7	C	1	C	5	9	4	1	2	7	3	4	3	C	3	7	4	0	0	0	9<SP≤12	
AC071RNMDKG/EU	0	1	B	1	7	C	1	C	5	9	B	3	2	7	3	4	3	C	3	7	4	0	0	0	12<SP≤15	
	0	1	B	1	7	C	1	C	5	4	3	6	2	7	4	7	5	0	3	7	6	0	0	0	0≤SP≤3	
	0	1	B	1	7	C	1	C	5	4	A	B	2	7	4	7	5	0	3	7	6	0	0	0	3<SP≤6	
	0	1	B	1	7	C	1	C	5	8	1	E	2	7	4	7	5	0	3	7	6	0	0	0	6<SP≤9	
	0	1	B	1	7	C	1	C	5	9	7	2	2	7	4	7	5	0	3	7	6	0	0	0	9<SP≤12	
AC100RNMDKG/EU	0	1	B	1	7	C	1	C	5	9	C	8	2	7	4	7	5	0	3	7	6	0	0	0	12<SP≤15	
	0	1	B	1	7	C	1	C	5	4	9	F	2	7	6	4	7	0	3	7	5	0	2	0	0≤SP≤4	
	0	1	B	1	7	C	1	C	5	9	1	7	2	7	6	4	7	0	3	7	5	0	2	0	4<SP≤8	
	0	1	B	1	7	C	1	C	5	9	9	C	2	7	6	4	7	0	3	7	5	0	2	0	8<SP≤12	
AC120RNMDKG/EU	0	1	B	1	7	C	1	C	5	A	E	1	2	7	6	4	7	0	3	7	5	0	2	0	12<SP≤15	
	0	1	B	1	7	C	1	C	5	4	2	4	2	7	7	8	8	2	3	7	4	0	4	0	0≤SP≤5.2	
	0	1	B	1	7	C	1	C	5	4	8	9	2	7	7	8	8	2	3	7	4	0	4	0	5.2<SP≤8.0	
	0	1	B	1	7	C	1	C	5	4	F	E	2	7	7	8	8	2	3	7	4	0	4	0	8.0<SP≤12.0	
AC140RNMDKG/EU	0	1	B	1	7	C	1	C	5	9	4	0	2	7	7	8	8	2	3	7	4	0	4	0	12.0<SP≤15.0	
	0	1	B	1	7	C	1	C	5	4	2	4	2	7	8	C	A	0	3	7	4	0	4	5	0≤SP≤5.2	
	0	1	B	1	7	C	1	C	5	4	8	9	2	7	8	C	A	0	3	7	4	0	4	5	5.2<SP≤8.0	
	0	1	B	1	7	C	1	C	5	4	F	E	2	7	8	C	A	0	3	7	4	0	4	5	8.0<SP≤12.0	
		0	1	B	1	7	C	1	C	5	9	4	0	2	7	8	C	A	0	3	7	4	0	4	5	12.0<SP≤15.0

Item	Model	SEG																								Static Pressure (Only Duct)
		1	2	3	4	5	6	7	8	9	10	11	12	13	14	15	16	17	18	19	20	21	22	23	24	
C-RAC	AC026RNADKG/EU	0	1	0	1	7	F	1	9	1	4	4	8	2	7	1	A	2	1	3	7	1	2	0	0	
	AC035RNADKG/EU	0	1	0	1	7	F	1	9	5	4	8	C	2	7	2	3	2	8	3	7	1	7	0	0	
	AC052RNADKG/EU	0	1	0	1	7	F	1	9	5	4	8	E	2	7	3	4	3	C	3	7	1	7	0	0	
	AC071RNADKG/EU	0	1	0	1	7	F	1	9	5	4	7	F	2	7	4	7	5	0	3	7	1	7	0	0	
	AC100RNTDKG/EU	0	1	1	1	7	F	1	9	3	5	7	0	2	7	6	4	6	C	3	7	1	7	0	0	
Ceiling	AC052RNCDKG/EU	0	1	3	1	7	F	1	9	5	0	F	5	2	7	3	4	3	C	3	7	0	0	0	0	
	AC071RNCDKG/EU	0	1	3	1	7	F	1	9	5	5	9	1	2	7	4	7	5	0	3	7	0	0	2	0	
	AC100RNCDKG/EU	0	1	D	1	7	C	1	C	5	4	3	9	2	7	6	4	7	0	3	7	0	0	4	2	
	AC120RNCDKG/EU	0	1	D	1	7	C	1	C	2	4	7	A	2	7	7	8	8	2	3	7	0	0	4	0	
	AC140RNCDKG/EU	0	1	D	1	7	C	1	C	5	4	B	E	2	7	8	C	A	0	3	7	0	0	4	5	
Console	AC026RNJDKG/EU	0	1	9	1	7	F	1	9	3	0	B	6	2	7	1	A	2	3	3	7	0	5	6	0	
	AC035RNJDKG/EU	0	1	9	1	7	F	1	9	3	0	D	8	2	7	2	3	2	8	3	7	0	6	6	0	
	AC052RNJDKG/EU	0	1	9	1	7	F	1	9	2	4	0	A	2	7	3	4	3	C	3	3	0	4	0	0	

4-2 Items to check before diagnostics

4-2-1 Test run mode and View mode

■ Main PCB image of outdoor unit

▶ Type A

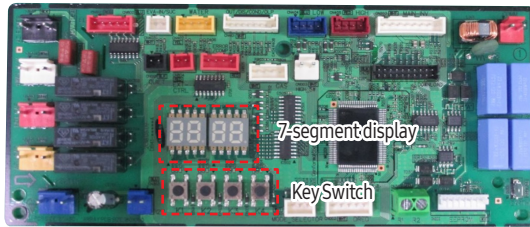

▶ Type B

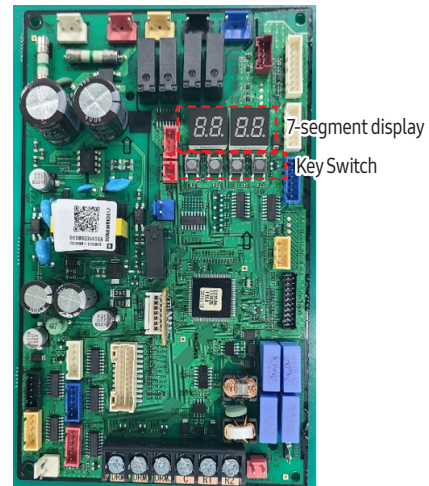
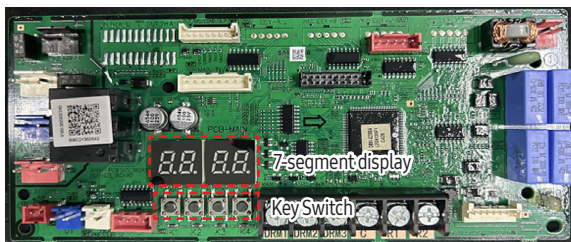

■ Display Option Key

▶ Type A

Key	Push type		Mode	Display			
				SEG1	SEG2	SEG3	SEG4
K1	Short	1st	Heating test mode	H	H	B	B
		2nd	Defrost test mode ¹⁾	H	3	B	B
		3rd	End Key operation	B	B	B	B
K2	Short	1st	Cooling test mode	H	2	B	B
		2nd	Inverter check	H	4	B	B
		3rd	Pump down	H	6	B	B
		4th	Unusual	H	B	B	B
		5th	End Key operation	B	B	B	B
K3	Short	1st	Reset Release Eco mode	B	B	B	B

¹⁾ Defrost test mode

Condition 1: The outdoor temperature is below 10°C.

Condition 2: All the temperature conditions should meet the defrost conditions.

▶ Type B

Key	Push type		Mode	Display			
				SEG1	SEG2	SEG3	SEG4
K1	Short	1st	Heating test mode	H	H	B	B
		2nd	Defrost test mode ¹⁾	H	3	B	B
		3rd	End Key operation	B	B	B	B
K2	Short	1st	Cooling test mode	H	2	B	B
		2nd	Inverter check	H	4	B	B
		3rd	Pump down	H	6	B	B
		4th	Unusual	H	B	B	B
		5th	Inverter Fault Detection (Comp#1) ²⁾	H	A	B	B
		6th	Auto trial operation	H	C	B	B
		7th	Unusual	H	E	B	B
		8th	End Key operation	B	B	B	B
K3	Short	1st	Reset Release Eco mode	B	B	B	B

¹⁾ Defrost test mode

Condition 1: The outdoor temperature is below 10°C.

Condition 2: All the temperature conditions should meet the defrost conditions.

²⁾ Indication on the display and action to take when an inverter fault is detected.

	SEG1	SEG2	SEG3	SEG4	Action to take
Fault detection is in progress	A	H	B	B	-
OK	A	H	0	H	-
NG	A	H	A	0	PBA defect: Replace the PBA
Check	A	H	C	H	Manual inspection is required
Going into fault detection mode failed	A	H	F	L	Try fault detection again

■ View Mode

※ For a function that is not supported, "-" is shown for SEG2, SEG3 or SEG4.

▶ Type A

K4 short push	Display contents	SEG1	SEG2	SEG3	SEG4	Unit
1	Order frequency	1	Hundreds digit	Tens digit	Units digit	Hz
2	Current frequency	2	Hundreds digit	Tens digit	Units digit	Hz
3	The number of preset indoor units	3	Hundreds digit	Tens digit	Units digit	EA
4	Ambient temperature sensor	4	Hundreds digit or "-" ¹⁾	Tens digit	Units digit	°C
5	Compressor discharge sensor	5	Hundreds digit	Tens digit	Units digit	°C
6	Eva Sensor	6	Hundreds digit or "-" ¹⁾	Tens digit	Units digit	°C
7	Condensor sensor	7	Hundreds digit or "-" ¹⁾	Tens digit	Units digit	°C
8	Current	8	Tens digit	Units digit	The first place of decimals	A
9	Outdoor fan RPM	9	Thousands digit	Hundreds digit	Tens digit	rpm
10	Target discharge temperature	A	Hundreds digit	Tens digit	Units digit	°C
11	EEV	B	Hundreds digit	Tens digit	Units digit	step
12	The capacity sum of indoor units	C	Tens digit	Unit digit	The first place of decimals	kW
13	Protective control	D	0: Cooling 1: Heating	Protective control 0: No Protective control 1: Freezing 2: Non-stop defrosting 3: Over-load 4: Discharge 5: Total electric current	Frequency status 0: Normal 1: Hold 2: Down 3: Up_limit 4: Down_limit	-
14	IPM temperature	E	Hundreds digit	Tens digit	Units digit	°C
15	The number of connected indoor units	F	0	Tens digit	Units digit	EA

¹⁾ Sub-zero temperatures are expressed as a minus, instead of hundreds digit.

► Type B

K4 short push	Display contents	SEG1	SEG2	SEG3	SEG4	Unit
1	Order frequency	1	Hundreds digit	Tens digit	Units digit	Hz
2	Current frequency	2	Hundreds digit	Tens digit	Units digit	Hz
3	The number of preset indoor units	3	Hundreds digit	Tens digit	Units digit	EA
4	Ambient temperature sensor	4	Hundreds digit or "-" ¹⁾	Tens digit	Units digit	°C or °F ²⁾
5	Compressor discharge sensor	5	Hundreds digit	Tens digit	Units digit	°C or °F ²⁾
6	Eva-Mid sensor	6	Hundreds digit or "-" ¹⁾	Tens digit	Units digit	°C or °F ²⁾
7	Condensor sensor	7	Hundreds digit or "-" ¹⁾	Tens digit	Units digit	°C or °F ²⁾
8	Current	8	Tens digit	Units digit	The first place of decimals	A
9	Outdoor fan RPM	9	Thousands digit	Hundreds digit	Tens digit	rpm
10	Target discharge temperature	A	Hundreds digit or "-" ¹⁾	Tens digit	Units digit	°C or °F ²⁾
11	EEV	B	Hundreds digit	Tens digit	Units digit	step
12	The capacity sum of indoor units	C	Tens digit	Unit digit	The first place of decimals	kW or kBtu/h ³⁾
13	Protective control	D	0: Cooling 1: Heating	Protective control 0: No Protective control 1: Freezing 2: Non-stop defrosting 3: Over-load 4: Discharge 5: Total electric current	Frequency status 0: Normal 1: Hold 2: Down 3: Up_limit 4: Down_limit	-
14	IPM temperature	E	Hundreds digit or "-" ¹⁾	Tens digit	Units digit	°C or °F ²⁾
15	The number of connected indoor units	F	Hundreds digit	Tens digit	Units digit	EA
16	ESC EEV (CAM)	G	Hundreds digit	Tens digit	Units digit	step
17	ESC IN sensor	H	Hundreds digit or "-" ¹⁾	Tens digit	Units digit	°C or °F ²⁾
18	ESC OUT sensor	I	Hundreds digit or "-" ¹⁾	Tens digit	Units digit	°C or °F ²⁾
19	View mode end	BLANK	BLANK	BLANK	BLANK	

¹⁾ Sub-zero temperatures are expressed as a minus, instead of hundreds digit.

²⁾ The temperature unit can be switched between Celsius and Fahrenheit through Setting outdoor unit option switches. (Default value is Celsius.)

³⁾ If the temperature unit is set to Fahrenheit through Setting outdoor unit option switches, the value is expressed in the unit of kBtu/h.

■ Version Check & Address Check

	Display contents	SEG1	SEG2	SEG3	SEG4	
K4 long push	-	Main micom version	Year (Dec)	Month (Hex)	Date (Tens digit)	Date (Units digit)
	After short push 1	Inverter micom version	Year (Dec)	Month (Hex)	Date (Tens digit)	Date (Units digit)
	After short push 2	E2P version	Year (Dec)	Month (Hex)	Date (Tens digit)	Date (Units digit)
	After short push 3	Page1-AUTO Page2 - (SEG1,2 - Indoor unit: "A","0") (SEG3,4 - Address: ex) 00)				
	After short push 4	Page1-MANU Page2 - (SEG1,2 - Indoor unit: "A","0") (SEG3,4 - Address: ex) 00)				

- Long push K4 (Main micom ver.) → short push 1 more (Inv. micom ver.) → short push 1 more (E2P. ver.) → short push 1 more (Automatic address) → short push 1 more (Manual address) → short push 1 more (Main micom ver.) → → Long push K4 (View mode end)

Test operation mode and check mode (Cont.)

■ Setting outdoor unit option switch and address manually

▶ Setting the option

- Press and hold K2 to enter the option setting. (Only available when the operation is stopped)
- If you enter the option setting, display will show the following.

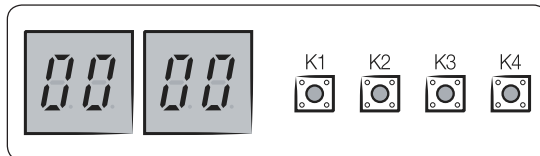

- Seg 1 and Seg 2 will display the number for selected option.
- Seg 3 and Seg 4 will display the number for set value of the selected option.

- If you have selected desired option, you can shortly press the K1 switch to adjust the value of the Seg 1, Seg 2 and change the function for the selected option

Example)

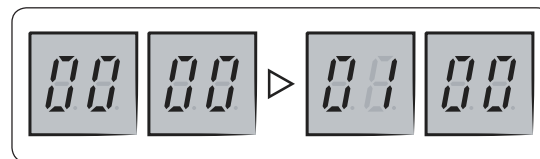

- If you have selected desired option, you can shortly press the K2 switch to adjust the value of the Seg 3, Seg 4 and change the function for the selected option.

Example)

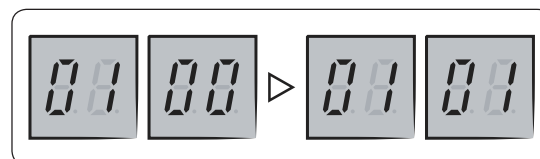

- After selecting the function for options, press and hold the K2 switch for 2 seconds. Edited value of the option will be saved when entire segments blinks and tracking mode begins.

⚠ Edited option will not be saved if you do not end the option setting as explained in above instruction.

- While you are setting the option, you may press and hold the K1 button to reset the value to previous setting.
- If you want to restore the setting to factory default, press and hold the K4 button while you are in the option setting mode.
 - If you press and hold the K4 button, setting will be restored to factory default but it doesn't mean that restored setting is saved. Press and hold the K2 button. When the segments shows that tracking mode is in progress, setting will be saved.

► Type A

※ Some functions may not be supported depending on the S/W version of the Main PCB.

Option item	Input unit	SEG1	SEG2	SEG3	SEG4	Function
Channel address	Main	0	0	A	U	Automatic setting (Factory default)
				00~15		Manual setting
Snow accumulation prevention control	Main	0	1	0	0	Disabled (Factory default)
				0	1	Enabled
Step for Silence mode	Main	0	2	0	0	Disabled (Factory default)
				0	1	Step1
				0	2	Step2
				0	3	Step3
Type of Silence mode	Main	0	3	0	0	Automatic Silence mode (Factory default)
				0	1	Manual Silence mode
Not applicable	Main	0	4	0	0	Not applicable
				0	1	Not applicable
Not applicable	Main	0	5	0	0	Not applicable
				0	1	Not applicable
Current restriction rate ¹⁾	Main	0	6	0	0	100% (Factory default)
				0	1	95%
				0	2	90%
				0	3	85%
				0	4	80%
				0	5	75%
				0	6	70%
				0	7	65%
				0	8	60%
				0	9	55%
				1	0	50%
				1	1	100%

► Type B

※ Some functions may not be supported depending on the S/W version of the Main PCB.

Option item	Input unit	SEG1	SEG2	SEG3	SEG4	Function
Channel address	Main	0	0	A	U	Automatic setting (Factory default)
				00~15		Manual setting
Snow accumulation prevention control	Main	0	1	0	0	Disabled (Factory default)
				0	1	Enabled
Step for Silence mode	Main	0	2	0	0	Disabled (Factory default)
				0	1	Step1
				0	2	Step2
				0	3	Step3
Type of Silence mode	Main	0	3	0	0	Automatic Silence mode (Factory default)
				0	1	Manual Silence mode
Temperature unit	Main	0	4	0	0	Celsius (default)
				0	1	Fahrenheit
Not applicable	Main	0	5	0	0	Not applicable
				0	1	Not applicable
Current restriction rate ¹⁾	Main	0	6	0	0	100% (Factory default)
				0	1	95%
				0	2	90%
				0	3	85%
				0	4	80%
				0	5	75%
				0	6	70%
				0	7	65%
				0	8	60%
				0	9	55%
				1	0	50%
				1	1	100%
Dedicated mode for cooling/ heating	Main	0	7	0	0	Cooling / Heating operation (default)
				0	1	Cooling operation only
				0	2	Heating operation only

•1) Current restriction rate: When restriction option is set, cooling and heating performance may decrease.

4-2-2 Eco Mode [Power Saving Mode]



Mode	Display				Eco Mode Lamp
	Segment 1	Segment 2	Segment 3	Segment 4	
Eco Mode	BLANK	BLANK	BLANK	BLANK	RED On
Eco Mode Exit	Press K3 to go out from the eco mode. At the driving signal or test run (cooling/heating) of the user, the mode is released.				Off

4-2-3. Error code [Indoor Unit]





■ 1Way CST: AC***RN1DKG

Abnormal conditions	LED lamp display					Remarks
	Operation	Defrost	Timer	Fan	Filter reset	
	Blue	Yellow				
⏻		⌚	🌀	🧺		
Power reset	●	X	X	X	X	
Error of temperature sensor in the indoor unit (Open/Short)	X	X	●	X	X	
Error of heat exchanger sensor in the indoor unit	●	X	●	X	X	
Error of the outdoor temperature sensor Error of the condensor temperature sensor Error of the discharge temperature sensor	●	X	X	●	X	
1. No communication for 2 minutes between indoor units (Communication error for more than 2 minutes) 2. Indoor unit receiving the communication error from outdoor unit 3. Outdoor unit tracking 3 minutes error 4. When sending the communication error from the outdoor unit, the mismatching of the communication numbers and installed numbers after completion of tracking. (Communication error for more than 2 minute	X	X	●	●	X	1. Indoor unit error (Display is unrelated with operation) 2. Outdoor unit error (Display is unrelated with operation)
1. Error of electronic expansion valve open 2. 2'nd detection of high temperature cond 3. 2'nd detection of high temperature discharge 4. Error of reverse phase 5. Compressor down due to 6th detection of freezing	X	X	●	●	●	
1. Detection of the float switch 2. Emergency alarm system on (Emergency Stop)	X	X	X	●	●	
EEPROM error EEPROM option error	●	●	●	●	●	
Error on indoor fan motor (E154)	X	X	X	●	X	
Outdoor valve clogging error	●	X	●	●	X	
Error due to connecting outdoor units that do not support the WindFree function	●	X	●	●	X	

●: On, ●: Flickering, X: Off

• If you turn off the air conditioner when the LED is flickering, the LED is also turned off.

■ 4Way CST (600x600): AC***RNNDKG

Abnormal conditions	LED lamp display				Remarks
	Operation	Defrost	Timer	Filter reset	
					
Power reset	●	X	X	X	
Error of temperature sensor in the indoor unit (Open/ Short)	X	●	X	X	
Error of heat exchanger sensor in the indoor unit (Open/Short)	●	●	X	X	
Error of fan motor in the indoor unit	X	X	●	X	
Error of the outdoor temperature sensor Error of the condensor temperature sensor Error of the discharge temperature sensor	●	X	●	X	
No communication for 2 minutes between indoor and outdoor unit (communication error for more than 2 minutes)	X	●	●	X	
Error of outdoor unit Error of the terminal block thermal fuse (Open)	X	●	●	●	
Detection of the float switch	X	X	●	●	
EEPROM ERROR EEPROM option error	●	●	●	●	
Outdoor valve clogging error	●	X	●	●	
Miss matching error between indoor unit and outdoor unit	●	●	X	●	

●: On, ●: Flickering, X: Off

- If you turn off the air conditioner when the LED is flickering, the LED is also turned off.

■ 4Way CST: AC***RN4DKG

Error Mode				Cause	Measures	Product operation with error			Diagnosis method
Operation	Defrost	Timer	Filter			Outdoor heat exchanger compressor	Outdoor heat exchanger fan	Indoor heat exchanger fan	
●	X	X	X	Power reset	-	Operation-off	Operation-off	Operation-off	-
X	●	X	X	Error of room temperature sensor in the indoor unit (Open/Short)	<ul style="list-style-type: none"> Check indoor temperature sensor connection. Check indoor temperature sensor's resistance value to see if it's short/open. 	Operation-off	Operation-off	Operation-off	-
●	●	X	X	Error of heat exchanger IN/OUT sensor in the indoor unit (Open/Short)	<ul style="list-style-type: none"> Check EVA IN/OUT sensor connection. Check EVA IN/OUT sensor's resistance value to see if it's short/open. 	Operation-off	Operation-off	Operation-off	-
X	X	●	X	Error of fan motor in the indoor unit	<ul style="list-style-type: none"> Check the connection of motor connector Check the speed of the motor fan 	Operation-off	Operation-off	Operation-off	-
●	X	●	X	Error of the outdoor temperature sensor Error of the condenser temperature sensor Error of the discharge temperature sensor	<ul style="list-style-type: none"> Check indoor temperature sensor connection. Check indoor temperature sensor's resistance value to see if it's short/open. 	Operation-off	Operation-off	Operation-off	-
X	●	●	X	No communication for 2 minutes between indoor and outdoor unit (communication error for more than 2 minutes)	<ul style="list-style-type: none"> Check connection between indoor and outdoor heat exchangers' communication cables 	Operation-off	Operation-off	Operation-off	-
X	●	●	●	Error of outdoor unit	<ul style="list-style-type: none"> Check error occurred with outdoor heat exchanger. TERMINAL Block thermal FUSE error.(OPEN) 	Operation-off	Operation-off	Operation-off	-
X	X	●	●	Detection of the float switch	<ul style="list-style-type: none"> Check float switch connection. Check whether the drain has been filled with water. 	Operation-off	Operation-off	Operation-off	-
●	●	●	●	EEPROM error EEPROM option error	<ul style="list-style-type: none"> Check if there is damage with EEPROM component. Check the indoor model to set the options. Inspection for match between indoor and outdoor machine models 	Operation-off	Operation-off	Operation-off	-
●	X	●	●	Outdoor valve clogging error.	<ul style="list-style-type: none"> High pressure check valve clogging. 	Operation-off	Operation-off	Operation-off	-
●	X	X	●	MDS (Motion Detecting Sensor) Error	<ul style="list-style-type: none"> Check MDS 	-	-	-	-
●	●	X	●	Error due to connecting outdoor units that do not support the Wind-Free function	<ul style="list-style-type: none"> Check outdoor main PBA S/W Check outdoor EEPROM 	-	-	-	-

○: On ●: Blink X: Off

■ 360 CST: AC***RN4PKG



























Ice blue	Yellow green
Blue	Red

Condition	Indoor unit display indications			
	Ice blue	Yellow green	Blue	Red
Power reset. (blinking once every 2 seconds)	●	X	X	X
In the defrost operation. (blinking once every 10 seconds)	●	X	X	X
Open or short circuit error of the indoor-temperature sensor.	X	X	X	●
Error of the outdoor unit.	X	X	●	X
Communication error between the indoor and outdoor units	X	●	X	X
Open or short circuit error of a sensor (evaporator-in, evaporator-out, or discharge sensor) in the indoor unit.	X	●	X	●
Error of the fan in the indoor unit.	X	X	●	●
1. Detection of the float switch 2. Emergency alarm system on (Emergency Stop)	X	●	●	X
Open circuit error of the thermal fuse.	●	X	●	X
EEPROM error	●	●	X	●
MDS (Motion Detecting Sensor) Error	●	●	●	X

●: On ●: Blink X: Off

Troubleshooting





































■ Duct: AC***RNLDKG, AC***RNMDKG
 ※ The receiver & display unit (DRK-A10N) needs to be connected to the indoor unit.





Abnormal conditions	Indicators					Remarks
						
	Blue	Red				
Power reset		X	X	X	X	
Error of Room sensor in the indoor unit (Open/Short)	X	X		X	X	
Error of EVA-IN,EVA-OUT sensor in the indoor unit (Open/Short)		X		X	X	
Error of Fan motor in the indoor unit	X	X	X		X	
Error of Outdoor or Terminal Block Thermal Fuse (Open)	X	X				
Clogging of outdoor's service valve		X	X			
Detection of the float switch	X	X	X			
Error of EEPROM or OPTION SETTING						
1. No communication for 2 minutes between indoor units (Communication error for more than 2 minutes) 2. Indoor unit receiving the communication error from outdoor unit 3. Outdoor unit tracking 3 minutes error 4. When sending the communication error from the outdoor unit, the mismatching of the communication numbers and installed numbers after completion of tracking. (Communication error for more than 2 minutes)	X	X			X	1. Indoor unit error (Display is unrelated with operation) 2. Outdoor unit error (Display is unrelated with operation)

 On,  Flickering, X: Off

• If you turn off the air conditioner when the LED is flickering, the LED is also turned off.

■ C-RAC AC**R1NADKG, AC**R1NTDKG





Abnormal conditions	Error code	LED Display		
			 OR 	 OR 
Error on indoor temperature sensor (Short or Open)	E121	X		X
1. Error on Eva-in sensor (Short or Open)	E122			X
2. Error on Eva-out sensor (Short or Open)	E123			X
3. Discharge sensor error (Short or Open)	E126			X
Indoor fan error	E154	X	X	
1. Error on outdoor temperature sensor (Short or Open)	E221			
2. Error on cond sensor	E237		X	
3. Error on discharge sensor	E251		X	
Other outdoor unit sensor error that is not on the above list				
1. When there is no communication between the indoor · outdoor units for 2 minutes	E101			
2. Communication error received from the outdoor unit	E102			
3. 3 minute tracking error on outdoor unit	E202			
4. Communication error after tracking due to unmatching number of installed units	E201	X		
5. Error due to repeated communication address	E108			
6. Communication address not confirmed	E109			
Other outdoor unit communication error that is not on the above list				
Self diagnosis error display				
1. Error due to opened EEV (2nd detection)	E151			
2. Error due to closed EEV (2nd detection)	E152			
3. Eva in sensor is detached	E128			
4. Eva out sensor is detached	E129			
5. Thermal fuse error (Open)	E198			

Abnormal conditions	Error code	LED Display		
			 OR 	 OR 
1. COND mid sensor is detached	E241			
2. Refrigerant leakage (2nd detection)	E554			
3. Abnormally high temperature on Cond (2nd detection)	E450			
4. Low pressure s/w (2nd detection)	E451			
5. Abnormally high temperature on discharged air on outdoor unit (2nd detection)	E416			
6. Indoor operation stop due to unconfirmed error on outdoor unit	E559			
7. Error due to reverse phase detection	E425			
8. Comp stop due to freeze detection (6th detection)	E403			
9. High pressure sensor is detached	E301	●	●	●
10. Low pressure sensor is detached	E306			
11. Outdoor unit compression ratio error	E428			
12. Outdoor sump down_1 prevention control	E413			
13. Compressor down due to low pressure sensor prevention control_1	E410			
14. Simultaneous opening of cooling/heating MCU SOL valve (1st detection)	E180			
15. Simultaneous opening of cooling/heating MCU SOL valve (2nd detection)	E181			
Other outdoor unit self-diagnosis error that is not on the above list				
EEPROM error	E162	●	●	●

●: On, ●: Flickering, X: Off

- If you turn off the air conditioner when the LED is flickering, the LED is also turned off.
- If you re-operate the air conditioner, it operates normally at first, then detect an error again.
- When E108 error occurs, change the address and reset the system.
Ex.) When address of the indoor unit #1 and #2 are set as 5, address of the indoor unit #1 will become 5 and indoor unit #2 will display E108, A002.

■ Ceiling: AC052/071RNCDKG

Abnormal conditions	LED lamp display					Remarks
						
Power reset	●	X	X	X	X	
Error of temperature sensor in indoor unit (OPEN/SHORT)	X	●	X	X	X	Displayed on appropriate indoor unit which is operating
Error of the indoor unit pipe sensor	●	●	X	X	X	Displayed on appropriate indoor unit which is operating
Error of the outdoor unit pipe sensor	●	X	●	X	X	Displayed on appropriate indoor unit which is operating Displayed on outdoor unit
Communication error (Transmitter, wired remote control)	X	●	●	X	X	Error of indoor unit: Displayed on the indoor unit regardless of operation
Communication error between indoor units	●	X	X	●	X	Error of outdoor unit: Displayed on the indoor unit which is operating
Error of peripherals option set-up	X	●	X	●	X	
EEPROM error	●	●	●	●	●	
EEPROM option error	●	●	●	●	●	
High pressure blockage error (Refrigerant completely Leakage error)	●	X	●	●	X	
Error of outdoor Unit/Self- Diagnosis (Check error code in outdoor unit or solution display or thermal fuse on Indoor's POWER T/B (open))	X	●	●	●	X	

●: On, ●: Flickering, X: Off

- If you turn off the air conditioner when the LED is flickering, the LED is also turned off.
- If you re-operate the air conditioner, it operates normally at first, then detects an error again.

















■ Ceiling: AC100/120/140RNCCKG





Abnormal conditions	LED lamp display				Remarks
	Blue	Green	Orange	Red	
Power reset	●	X	X	X	0.5[S]=On, 0.5[S]=Off
Operation on	●	X	X	X	
Operation off	X	X	X	X	
Reservation	X	●	X	X	
Filter sign	X	X	●	X	
Defrosting	●	X	X	X	1[S]=On, 9[S]=Off
Smart install Error	X	X	X	●	
Communication error between indoor units and outdoor unit	X	●	X	X	
EEPROM error /EEPROM option error	●	X	X	●	
Error of temperature sensor in indoor unit (open/short)	X	X	X	●	
Error of outdoor Unit/Self-Diagnosis	X	X	●	X	
Error of the indoor unit pipe sensor	X	●	X	●	
Indoor fan error	●	●	X	X	
Thermal fuse open error	●	X	●	X	
Indoor unit float S/W 2nd detection	X	●	●	X	

●: On, ●: Flickering, X: Off

- If you turn off the air conditioner when the LED is flickering, the LED is also turned off.
- If you re-operate the air conditioner, it operates normally at first, then detects an error again.
- If the LED displays only one color, it is turned on for a second and turned off for a second.
- If the LED displays more than two colors, each color is shown for a second alternately.

■ Console: AC***RNJDKG

Abnormal conditions	Error code	LED Display				
						
Error on indoor temperature sensor (Short or Open)	E121	X	X		X	X
1. Error on Eva-in sensor (Short or Open)	E122		X		X	X
2. Error on Eva-out sensor (Short or Open)	E123					
3. Discharge sensor error (Short or Open)	E126					
Indoor fan error	E154	X	X	X		X
1. Error on outdoor temperature sensor (Short or Open)	E221					
2. Error on cond sensor	E237					
3. Error on discharge sensor	E251		X	X		X
Other outdoor unit sensor error that is not on the above list						
1. When there is no communication between the indoor · outdoor units for 2 minutes	E101					
2. Communication error received from the outdoor unit	E102					
3. 3 minute tracking error on outdoor unit	E202					
4. Communication error after tracking due to unmatching number of installed units	E201	X	X			X
5. Error due to repeated communication address	E108					
6. Communication address not confirmed	E109					
Other outdoor unit communication error that is not on the above list						
Self diagnosis error display						
1. Error due to opened EEV (2nd detection)	E151					
2. Error due to closed EEV (2nd detection)	E152					
3. Eva in sensor is detached	E128	X	X			
4. Eva out sensor is detached	E129					
5. Thermal fuse error (Open)	E198					

Abnormal conditions	Error code	LED Display				
						
1. COND mid sensor is detached	E241					
2. Refrigerant leakage (2nd detection)	E554					
3. Abnormally high temperature on Cond (2nd detection)	E450					
4. Low pressure s/w (2nd detection)	E451					
5. Abnormally high temperature on discharged air on outdoor unit (2nd detection)	E416					
6. Indoor operation stop due to unconfirmed error on outdoor unit	E559					
7. Error due to reverse phase detection	E425					
8. Comp stop due to freeze detection (6th detection)	E403					
9. High pressure sensor is detached	E301	X	X	●	●	●
10. Low pressure sensor is detached	E306					
11. Outdoor unit copression ration error	E428					
12. Outdoor sump down_1 prevetion control	E413					
13. Compressor down due to low pressure sensor prevention control_1	E410					
14. Simultaneous opening of cooling/heating MCU SOL valve (1st detection)	E180					
15. Simultaneous opening of cooling/heating MCU SOL valve (2nd detection)	E181					
Other outdoor unit self-diagnosis error that is not on the above list						
Flowating s/w (2nd detection)	E153	X	X	X	●	●
EEPROM error	E162	●	●	●	●	●
EEPROM option error	E163	●	●	●	●	●
Error due to incompatible indoor unit	E164	X	X	X	X	●

●: On, ◐: Flickering, X: Off

• If you turn off the air conditioner when the LED is flickering, the LED is also turned off.

4-2-4 Outdoor Unit

No.	Error Code	Meaning	Remarks
1	E108	Error due to duplicated communication address	Check on repeated indoor unit main address
2	E116	R-32 detection sensor 'Short' or 'Open' or 'Abnormal signal' error.	1. Check R-32 sensor connector. 2. Check R-32 sensor wire. 3. Check R-32 sensor. 4. Change R-32 sensor.
3	E118	Indoor fan controller PCB overheat error	Check Indoor fan controller PCB
4	E121	Error on room temperature sensor of indoor unit (Short or Open)	Indoor unit Room Thermistor Open/Short
5	E122	Error on EVA IN sensor of indoor unit (Short or Open)	Indoor unit EVA_IN Thermistor Open/Short
6	E123	Error on EVA OUT sensor of indoor unit (Short or Open)	Indoor unit EVA_OUT Thermistor Open/Short
7	E153	Error on float switch (2nd detection)	Indoor unit Float Switch Open/Short Drain Pump operation Check
8	E154	Indoor fan error	Check on indoor unit indoor Fan operation
9	E164	Error due to connecting outdoor units that do not support the Wind-Free function	Check outdoor main PBA S/W, Check outdoor EEPROM data
10	E198	Error on thermal fuse of indoor unit (Open)	Thermal Fuse Open Check of indoor unit Terminal Block
11	E201	Communication error between the indoor unit and outdoor unit (Pre-tracking failure or when the actual number of indoor units are different from the indoor unit quantity setting on the outdoor unit) Error due to communication tracking failure after initial power is supplied (The error occurs regardless of the number of units.)	Check indoor quantity setting in outdoor
12	E202	Communication error between indoor unit and outdoor unit (When there is no response from indoor units after tracking is completed)	Check electrical connection and setting between indoor unit and outdoor unit
13	E203	Communication error between the outdoor unit and main micom (For PF #4 to #6 controllers, error will be determined from the time when the compressor is turned on.)	Check electrical connection and setting between outdoor unit MAIN PBA - INVERTER PBA
14	E205	Main PBA - other PBA Communication error (All other PBA communication error)	1. Check Main PBA connectors 2. Check other PBA connectors 3. Change Main PBA
15	E206	Main PBA - other PBA communication error (Some of PBA communication) C002: Fan PCB communication error C003: INV1 communication error	1. Check Main PBA connectors 2. Check other PBA connectors 3. Change other PBA
16	E221	Error on outdoor temperature sensor (Short or Open)	Check Outdoor sensor Open / Short
17	E231	Error on outdoor COND OUT sensor (Short or Open)	Check Cond-Out sensor Open / Short
18	E251	Error on discharge temperature sensor of compressor 1 (Short or Open)	Check Discharge sensor Open / Short
19	E320	Error on OLP sensor (Short or Open)	Check OLP sensor Open / Short
20	E321	Error on ESC IN temperature sensor (Short or Open)	Check ESC IN sensor Open / Short
21	E322	Error on ESC OUT temperature sensor (Short or Open)	Check ESC OUT sensor Open / Short
22	E381	INVERTER PCB overheat error	Check Outdoor Inverter PBA
23	E383	Outdoor Fan#1 PCB overheat error	1. Change motor 2. Change INV PCB
24	E403	Compressor down due to freeze protection control	Check Outdoor Cond.

No.	Error Code	Meaning	Remarks
25	E404	System stops due to overload protection control	Check Comp. when it starts
26	E407	High Pressure Switch Error or High Pressure Switch Connector Open	Check Comp Pressure or Check the Connection of the CN003 on the MAIN-OUT PBA (Error that only covers an outdoor unit capacity of 7.1 KW or less)
27	E416	System stops due to discharge temperature	-
28	E422	Blockage detected on high pressure pipe during cooling operation	1. Check if the service valve is open 2. Check for refrigerant leakage (pipe connections, heat exchanger) and charge refrigerant if necessary 3. Check if there's any blockage on the refrigerant cycle (indoor unit/outdoor unit) 4. Check if additional refrigerant has been added after pipe extension
29	E425	Reverse phase or open phase	Check whether 3 phase is reversed or opened.
30	E440	Heating operation restricted at outdoor temperature over Theat_ high value (default:30°C)	1. Check the range of temperature limited for heating operation 2. Check the outdoor temperature sensor
31	E441	Cooling operation restricted at outdoor temperature below Tcool_ low value (default:0°C)	1. Check the range of temperature limited for cooling operation 2. Check the outdoor temperature sensor
32	E446	Outdoor Fan#1 motor Operation error	1. Change motor 2. Change INV PCB
33	E447	Outdoor Fan#1 motor wire disconnection error	1. Check motor connector 2. Change motor 3. Change INV PCB
34	E455	Outdoor Fan#1 IPM overheat error	1. Change motor 2. Change INV PCB
35	E458	Fan speed error	FAN1 ERROR
36	E461	Error due to operation failure of inverter compressor	-
37	E462	System stops due to full current control	-
38	E463	Over current trip / PFC over current error	Check OLP sensor
39	E464	IPM Over Current (O.C)	1. Check if the service valve is open 2. Check the state of refrigerant 3. Check if connecting wire and the pipe are OK 4. Check the compressor
40	E465	Comp. Overload error	-
41	E466	DC-Link voltage under/over error	Check AC Power and DC Link Voltage
42	E467	Error due to abnormal rotation of the compressor or unconnected wire of compressor	Check Comp wire
43	E468	Error on current sensor (Short or Open)	Check Outdoor Inverter PBA.
44	E469	Error on DC-Link voltage sensor (Short or Open)	-
45	E470	Outdoor unit EEPROM Read/Write error (Option)	Check Outdoor EEPROM Data
46	E471	Outdoor unit EEPROM Read/Write error (H/W)	Check Outdoor EEPROM PBA
47	E474	Error on IPM Heat Sink sensor of inverter 1 (Short or Open)	Check Outdoor Inverter PBA.
48	E475	Error on inverter fan 2	FAN2 ERROR
49	E478	Outdoor Fan#1 motor overcurrent error	1. Change motor 2. Change INV PCB

No.	Error Code	Meaning	Remarks
50	E483	Overvoltage of H/W detect DC link	Check AC Power
51	E484	PFC Overload (Over current) Error	Check Outdoor Inverter PBA.
52	E485	Error on input current sensor of inverter 1 (Short or Open)	Check Outdoor EEPROM PBA
53	E486	Outdoor Fan#1 high voltage or low voltage error	1. Change motor 2. Change INV PCB
54	E488	Inverter input voltage sensor error	Check Outdoor Inverter PBA
55	E489	FAN #1 motor current limiting error	1. Change motor 2. Change INV PCB
56	E493	FAN #1 motor output current error	1. Change motor 2. Change INV PCB
57	E496	FAN #1 motor voltage sensor error	1. Change motor 2. Change INV PCB
58	E499	FAN #1 IPM temperature sensor error	1. Change motor 2. Change INV PCB
59	E500	IPM overheat error on inverter 1	Check Outdoor Inverter PBA.
60	E507	Error due to high pressure switch open or compressor down by high pressure	-
61	E508	Smart install is not installed	-
62	E534	Blockage detected on high pressure pipe during heating operation.	1. Check if the service valve is open 2. Check if there's any blockage on the refrigerant cycle (indoor unit/outdoor unit) 3. Check the EEV connection and operation 4. Check if the connecting wire and the pipe are OK 5. Check the compressor
63	E554	Gas leak detected	Check the refrigerant
64	E556	Error due to mismatching capacity of indoor and outdoor unit	Check the indoor and outdoor unit capacity
65	E557	DPM remote controller option error	Check the indoor option code
66	E563	Error due to mismatching indoor and outdoor unit	Check the outdoor EEPROM data and indoor option code
67	E590	Inverter EEPROM Checksum error	-
68	E594	Fan EEPROM CheckSum error	1. Check Fan EEPROM
69	E601	Communication error between wired remote control and indoor unit	1. Check remote control wire connectors. 2. Change wired remote control.
70	E665	External Contact Input ERROR	1. Check the External float switch connection. 2. Check whether the drain has been filled with water. 3. Check the emergency alarm system (Emergency Stop)
71	E695	R-32 detection sensor life unpredictable error	1. Check R-32 sensor. 2. Change R-32 sensor.
72	E697	R-32 detection sensor 2nd detecting error	1. Open the window to ventilate. 2. Contact service center.
73	E698	R-32 detection sensor failure error	1. Check R-32 sensor connector. 2. Check R-32 sensor. 3. Change R-32 sensor.
74	E699	R-32 detection sensor replacement notification error	Change R-32 sensor.
75	E700	R-32 detection sensor Life-expiration error	Change R-32 sensor.

4-2-5 Wired remote controller

- If an error occurs, () icon will be displayed on the wired remote controller.
- Press the Test button to see the error code.

Error mode	Contents	Measure	Product operation in error condition	Error type
			Outdoor unit/Compressor/Indoor unit	
101	Indoor unit communication error	Check the communication cable of indoor unit. Check the DC output voltage at the communication terminal.	Operation Off	Communication error
108	Duplicated address setting error	Check address setting of Indoor units.	Operation Off	Communication error
109	No response error address from indoor unit	Check indoor unit's quantity setting in outdoor unit. Check electrical connection and setting.	Operation Off	Communication error
121	Indoor temperature sensor (open/short error)	Check indoor unit room temperature sensor. Check indoor unit PCB connector CN41. (White)	Operation Off	Indoor sensor error
122	Indoor unit Eva In sensor (Open/Short)	Check indoor unit pipe sensor. Check indoor PCB connector CN41.(White)	Operation Off	Indoor sensor error
153	Indoor floating switch secondary detection	Check indoor unit float sensor. Check indoor PCB connector CN5. (Black)	Operation Off	Self diagnostic error
202	Indoor/outdoor communication error (1 min)	Check the communication connection between indoor and outdoor units. Check the power line and communication cable connection status	Operation Off	Communication error
203	Communication error between indoor/outdoor INV↔MAIN MICOM (1 min)	Check MAIN MICOM. Check INVERTER MICOM.	-	Communication error
221	Outdoor temperature sensor error	Check sensor connection status. Check sensor location. Check sensor resistance.	Operation Off	Outdoor sensor error
231	COND temperature sensor error	Check sensor connection status. Check sensor location. Check sensor resistance.	Operation Off	Outdoor sensor error
251	[Inverter] Emission temperature sensor error	Check sensor connection status. Check sensor location. Check sensor resistance.	Operation Off	Outdoor sensor error
403	Detection of Indoor Freezing (when Comp. Stops)	Check whether the indoor unit air intake is blocked. Check the operation of the indoor fan.	Operation Off	Outdoor unit protection control error
404	Protection of Outdoor Overload (when Comp. Stops)	Check sensor connection status. Check sensor location. Check sensor resistance.	Operation Off	Outdoor unit protection control error
407	High Pressure Switch Error or High Pressure Switch Connector Open	Check Comp Pressure Check the Connection of the CN003 on the MAIN-OUT PBA (Error that only covers an outdoor unit capacity of 7.1 KW or less)	Outdoor Operation Off	Outdoor Unit Protection Control Error
416	Emission temperature excessively high	No error. (DISCHARGE temperature control)	-	Outdoor unit protection control error
422	High pressure blockage error (Refrigerant completely Leakage error)	Check whether the outdoor unit service valve is open. Check the connection of the pipes. Check the operation of the EEV. Check for refrigerant leakage. (Completely leakage).	Operation Off	Self diagnostic error

Wired remote controller (cont.)

Error mode	Contents	Measure	Product operation in error condition	Errortype
			Outdoor unit/Compressor/Indoor unit	
440	Heating operation blocked	Check the operation setting state. Check temperature sensor.	Operation Off	Self diagnostic error
441	Cooling operation blocked	Check the operation setting state. Check temperature sensor.	Operation Off	Self diagnostic error
458	Outdoor fan 1 error	Check input power connection status. Check the connection status between the motor and outdoor unit PCB. Check indoor/outdoor fuse.	Operation Off	Self diagnostic error
461	[Inverter] Compressor startup error	Check the compressor connection status. Check the resistance between difference phases of the compressor.	Operation Off	Outdoor unit protection control error
462	[Inverter] Total current error/ PFC over current error	Check the input power Check the refrigerant charging status Check the normal operation of outdoor fan	Operation Off	Outdoor unit protection control error
463	OLP Overheat and Comp. Stop	Reconfirm the opening of the service valve. Check for leaks from the connection part of the pipe and product or from the pipe joint. Change the outdoor unit location and direction. Refill the refrigerant after checking the leaking part. Reinstall the outdoor unit set.	Operation Off	Outdoor unit protection control error
464	[Inverter] IPM over current error	Check refrigerant charging Check the compressor connection status and normal operation Check the obstacles around the indoor and outdoor units Check whether the outdoor unit service valve is open Check whether the indoor/outdoor installation pipe/wiring are correct	Operation Off	Outdoor unit protection control error
465	Compressor/limit error	Check the compressor connection status Check the resistance between difference phases of the compressor	Operation Off	Outdoor unit protection control error
466	DC LINK over/low voltage error	Check input power Check AC power connection	Restart in 3 minutes	Outdoor unit protection control error
467	[Inverter] Compressor rotation error	Check the compressor connection status Check the resistance between difference phases of the compressor	Operation Off	Outdoor unit protection control error
468	[Inverter] Current sensor error	Check EEPROM DATA Check the normal operation of PCB	Operation Off	Outdoor unit protection control error
469	[Inverter] DC LINK voltage sensor error	Check the input power connection Check the status of RY21 and R200 in the INVERTER PCB	Operation Off	Outdoor unit protection control error
400	EEPROM Read/Write error	-	Operation Off	Outdoor unit protection control error

Wired remote controller (cont.)

Error mode	Contents	Measure	Product operation in error condition	Error type
			Outdoor unit/Compressor/Indoor unit	
401	[Inverter] OTP error	Check EEPROM DATA Check the normal operation of PCB	Operation Off	Outdoor unit protection control error
402	AC ZERO CROSSING SIGNAL OUT error	Check the input power status	Operation Off	Outdoor unit protection control error
403	Compressor LOCK error	Check the compressor connection status Check the resistance between difference phases of the compressor	Operation Off	Outdoor unit protection control error
405	Outdoor fan 2 error	Check the input power connection status Check the connection status of the motor and the outdoor unit PCB Check the indoor/outdoor unit fuse	Operation Off	Self diagnostic error
500	IPM Overheat Error for Outdoor Unit Inverter Comp.	Change the location of the outdoor unit if the temperature is abnormally high when the heatproof plate is checked. Reconnect the screws. Replace the outdoor unit fan. Replace the PBA of the outdoor unit.	Operation Off	Outdoor unit protection control error
554	Gas leak error	Check the refrigerant charging status Check the indoor EVA sensor Check if the outdoor unit service valve is open Check that the indoor/outdoor installation pipe/wiring are correct	Operation Off	Self diagnostic error
556	Capacities not matched	Check the option code of the indoor unit	Operation Off	Outdoor unit protection control error
601	Communication error between the indoor unit and wired remote controller	Check the connection wire between the indoor unit and the wired remote controller	Normal operation	Wired remote controller error
602	Communication error between the Master and Slave wired remote controllers	Check the option switch for defining the Master and Slave (only one Master and one Slave can exist)	Normal operation	Wired remote controller error
606	COM1/COM2 cross installation error	Check that wired remote controller is connected to the COM2 terminal of the indoor unit	Normal operation	Wired remote controller error
8E8	Wired remote controller COM2 option setting error	Check that Com1, Com2 setting DIP switch is set to Com2	Normal operation	Wired remote controller error

4-3 Troubleshooting by symptoms

4-3-1 Indoor temperature sensor (open/short)

Indoor unit display	X (Operation) ● (Defrost) X (Timer) X (Filter)
Symptom	In case of open or short circuit of indoor temperature sensor
Failure	Short or leakage of the corresponding sensor

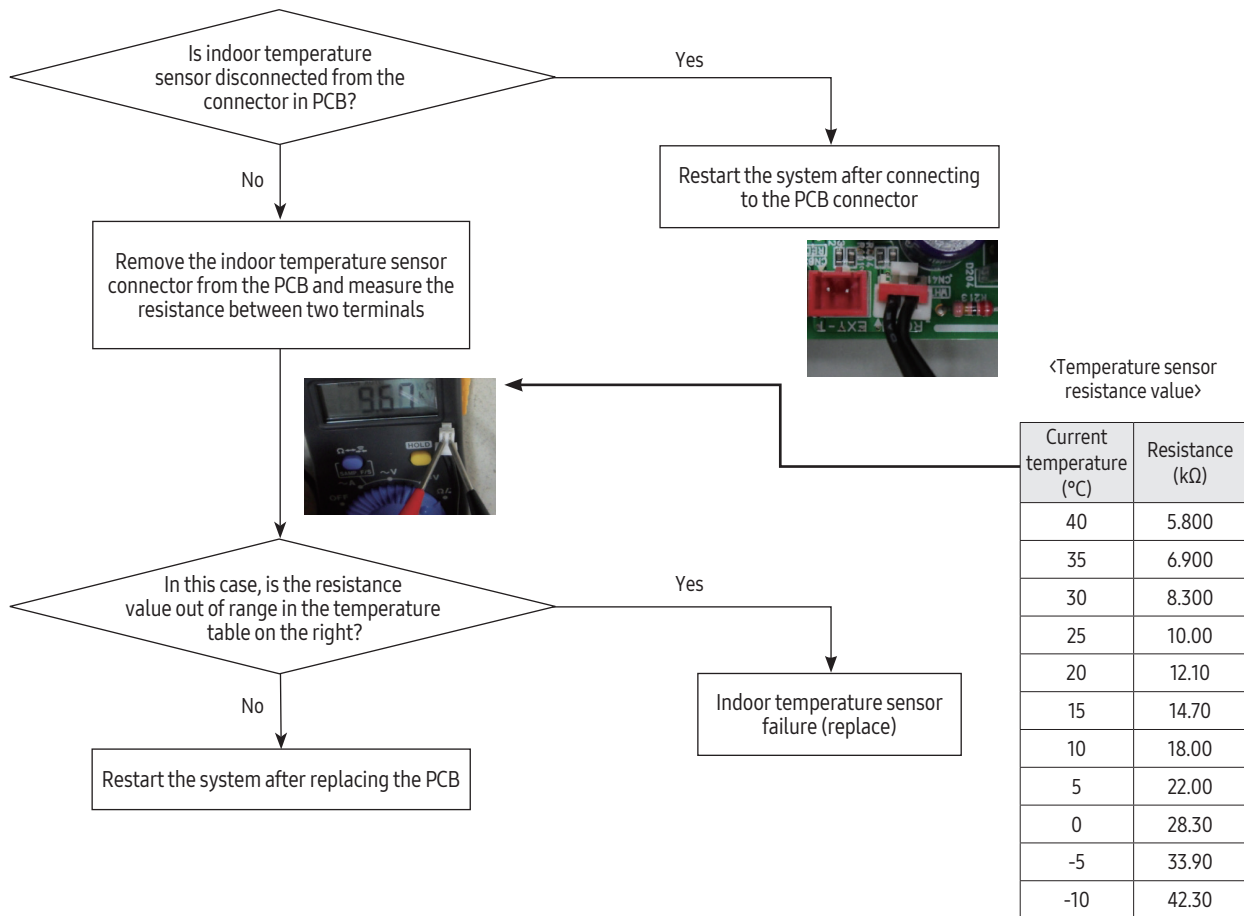

4-3-2 Indoor heat exchanger temperature sensor (open/short)

Indoor unit display	● (Operation) ● (Defrost) X (Timer) X (Filter)
Symptom	Short or open circuit of indoor heat exchanger temperature sensor
Failure	Short or open circuit in the corresponding sensor

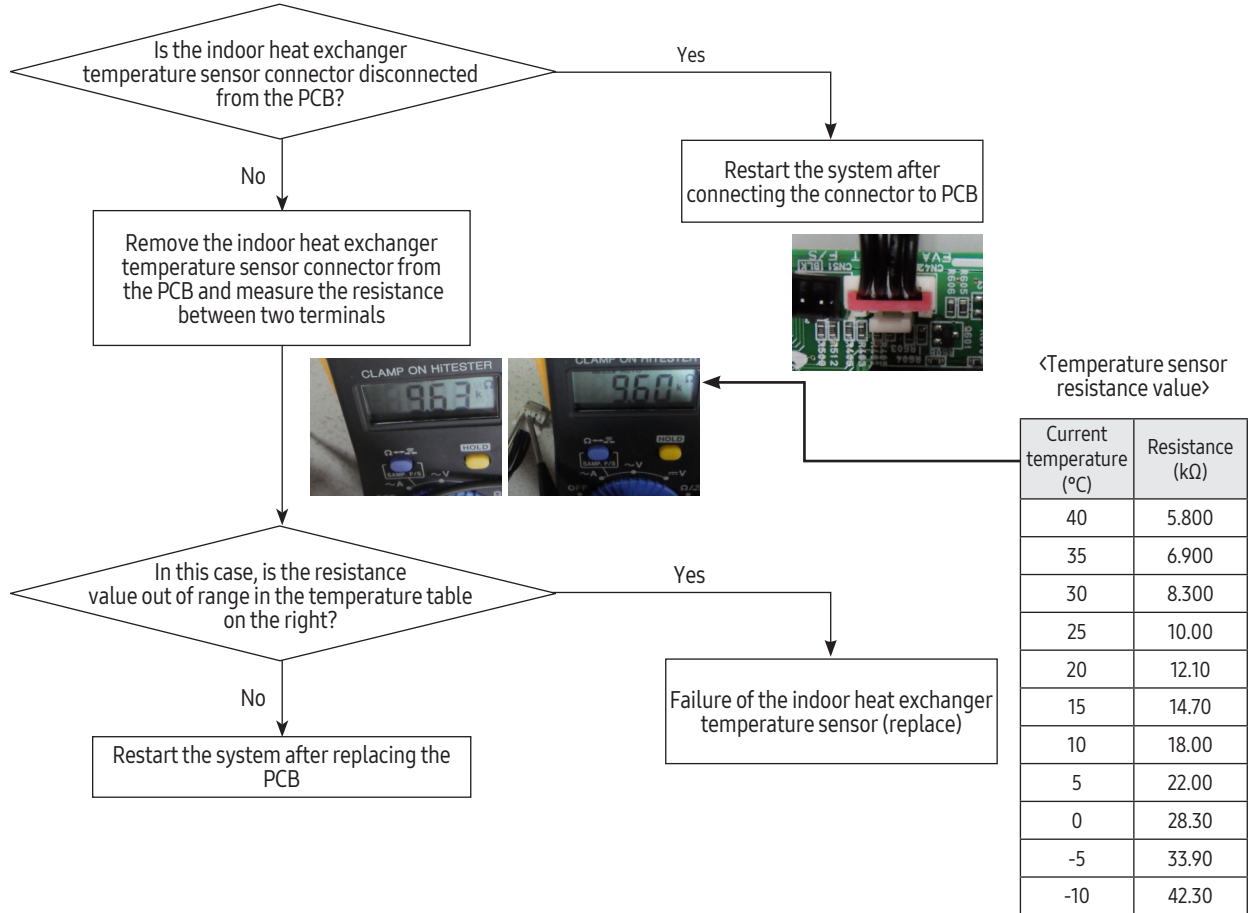

4-3-3 Indoor FAN error

Indoor unit display	X (Operation) X (Defrost) ● (Timer) X (Filter)
Symptom	Indoor unit fan does not run/Runs at excessive high speed and stops.
Failure	. Motor connector break away . Indoor unit FAN does not run: Defective motor or PBA

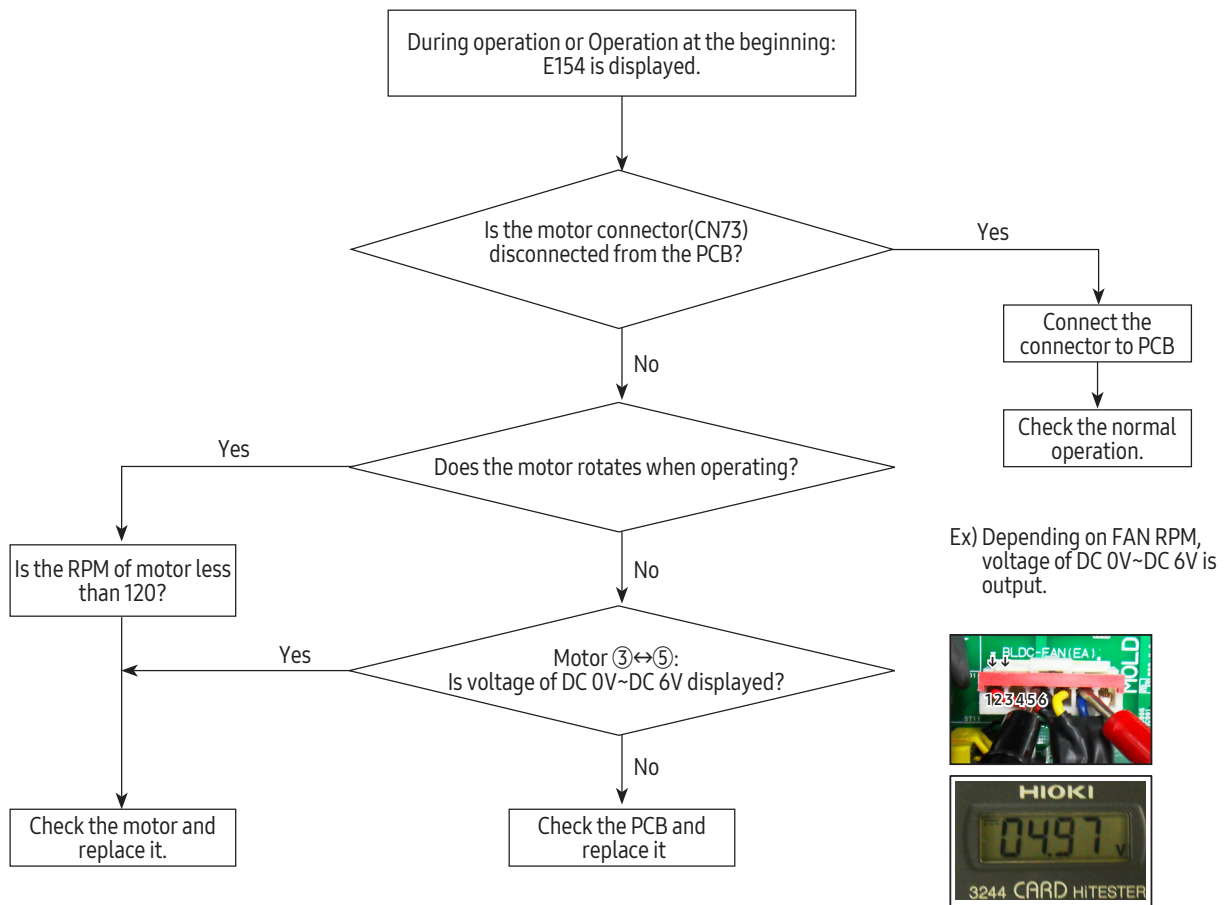

4-3-4 Communication error after finishing Tracking

Indoor unit display	X (Operation) ● (Defrost) ● (Timer) X (Filter)
Symptom	Communication error between the indoor and outdoor unit for two minutes
Failure	Communication error between the indoor unit and outdoor unit

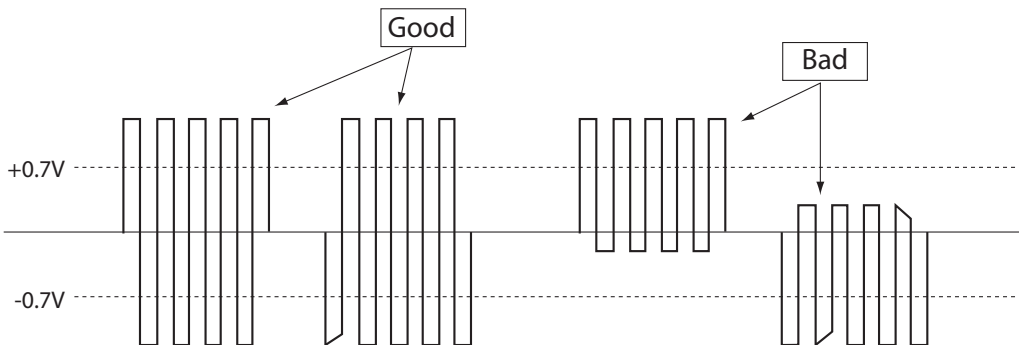
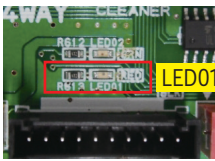
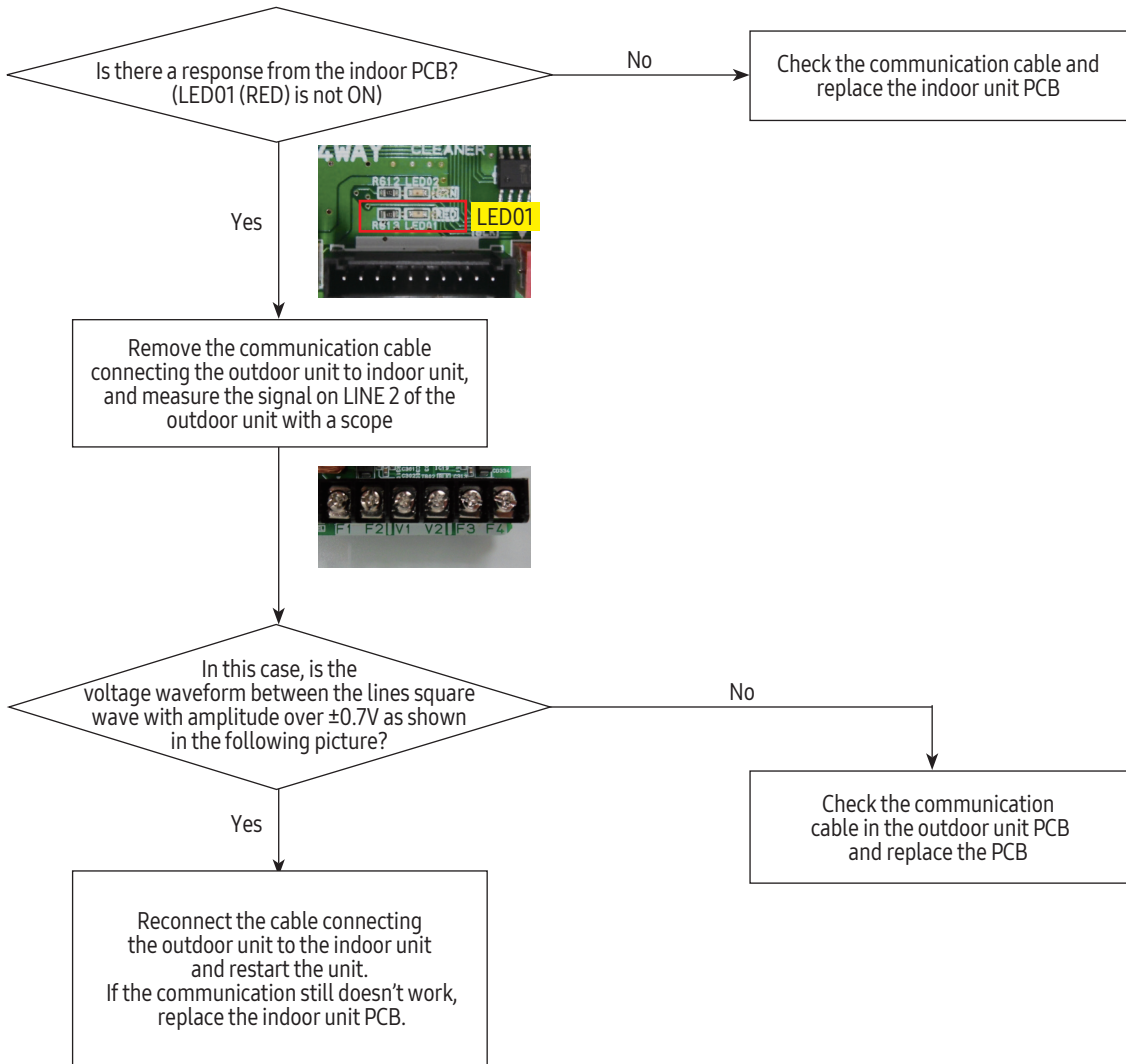

4-3-5 Indoor unit float sensor error

Indoor unit display	X (Operation) X (Defrost) ● (Timer) ● (Filter)
Symptom	The indoor unit floating sensor is open and that state is maintained for more than one minute
Failure	Increase in the drain pan water level due to failure of the indoor unit drain pump, or float sensor failure

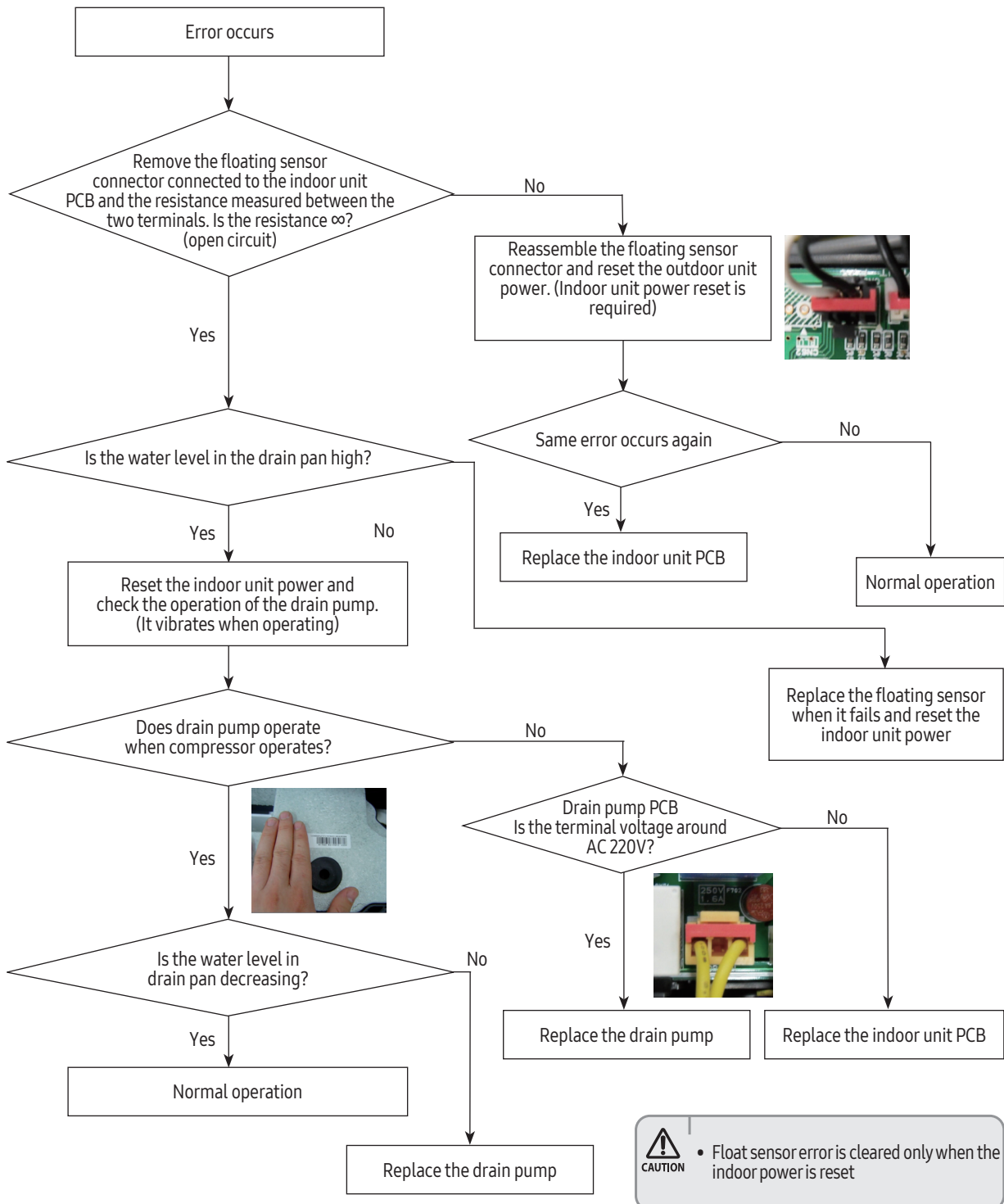

4-3-6 EEPROM circuit failure

Indoor unit display	● (Operation) ● (Defrost) ● (Timer) X (Filter)
Symptom	EEPROM circuit failure
Failure	EEPROM component failure, EEPROM circuit parts missing/damaged/soldering failure

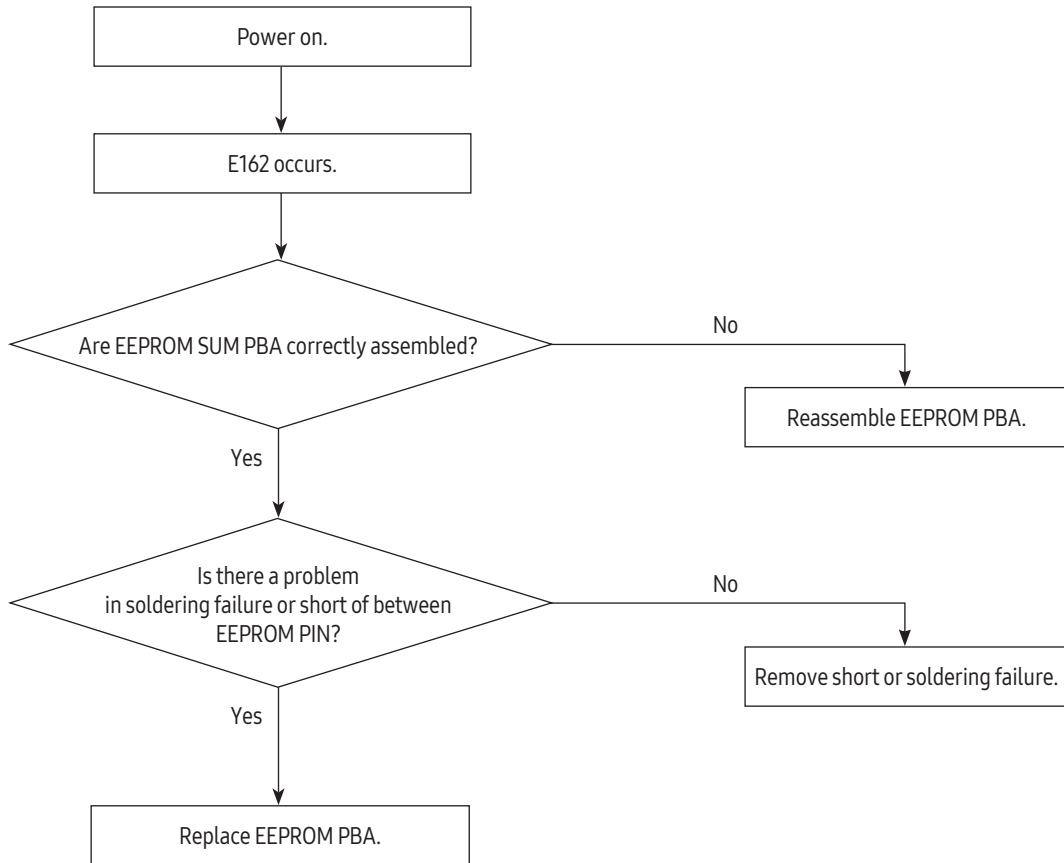

4-3-7 E407

Indoor unit display	
Symptom	High Pressure Switch Error or High Pressure Switch Connector Open
Failure	Check Comp Pressure Check the Connection of the CN003 on the MAIN-OUT PBA (Error that only covers an outdoor unit capacity of 7.1 KW or less)

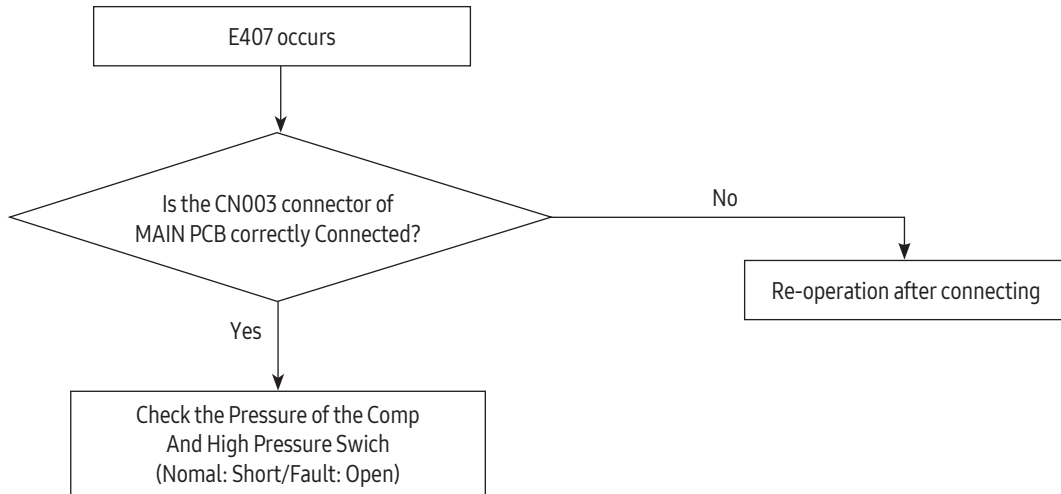

4-3-8 When the outdoor unit power is not ON - Initial Diagnosis: 3-phase products

1. Test items

- 1) Check the power connection of outdoor unit.
 - 2) Check the whole connection part of the power wire.
 - 3) Check the power on the indoor unit.
 - 4) Check the connection of the power wire of the Terminal Block.
 - 5) Check the connection of the power wire between the Main↔EMI PBA of the outdoor unit.
 - 6) Connect the power wire. (Never forget to turn off the power of the Terminal Box).
 - 7) Check the power supply parts. (Check after turning off the power of the Terminal Box!)
 - 8) Check everything is normal after separating the fan motor connector and resetting the power.
(Separate the connector after turning off the power of the Terminal Box! When detaching and attaching the connector during power supply, the motor can be damaged.)
- 7-segment off.
 - Conduct the following test if the mode is not Eco-mode (power saving mode).

2. Check procedure

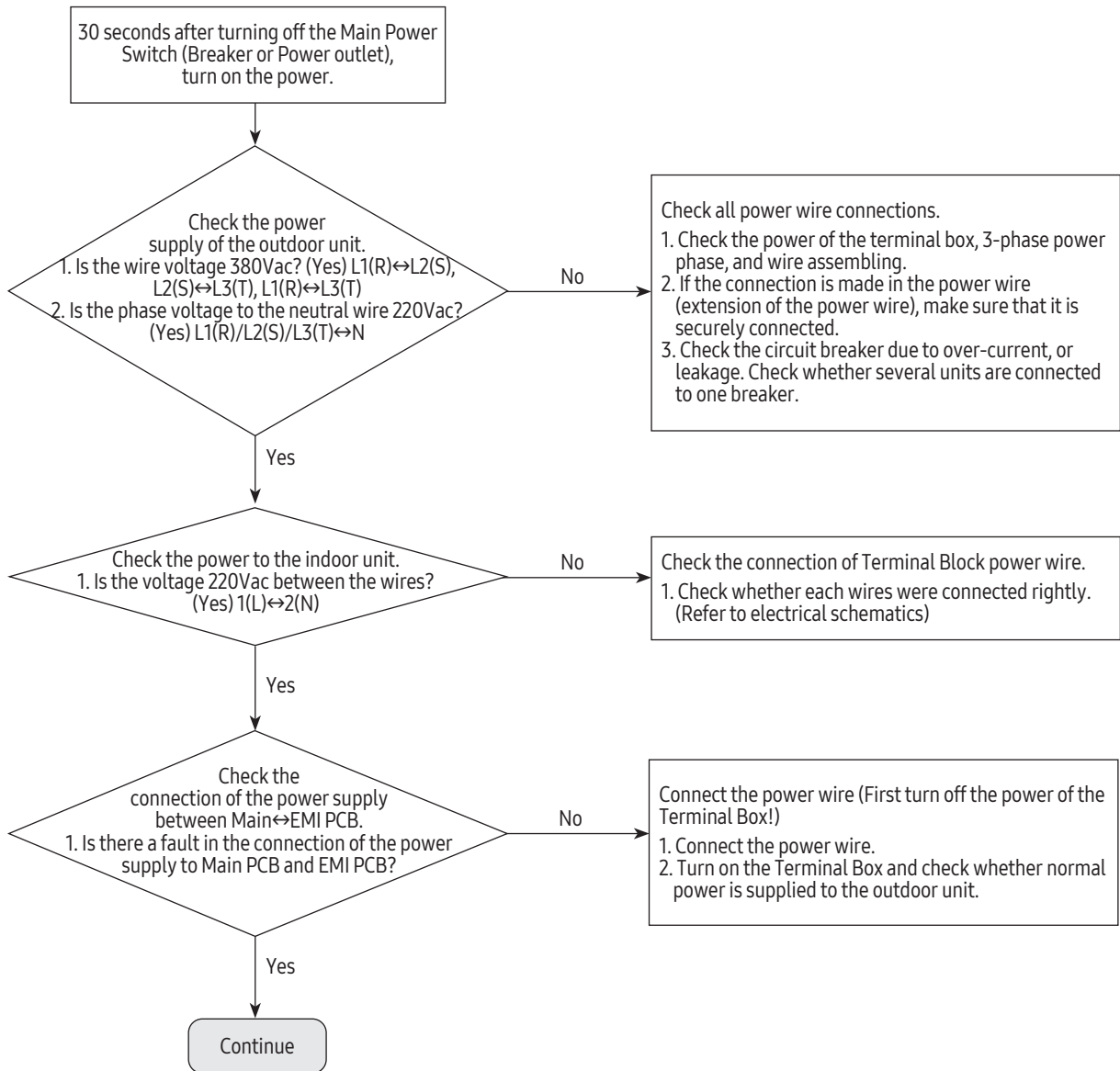

When the outdoor unit power is not ON - Initial Diagnosis: 3-phase products (cont.)

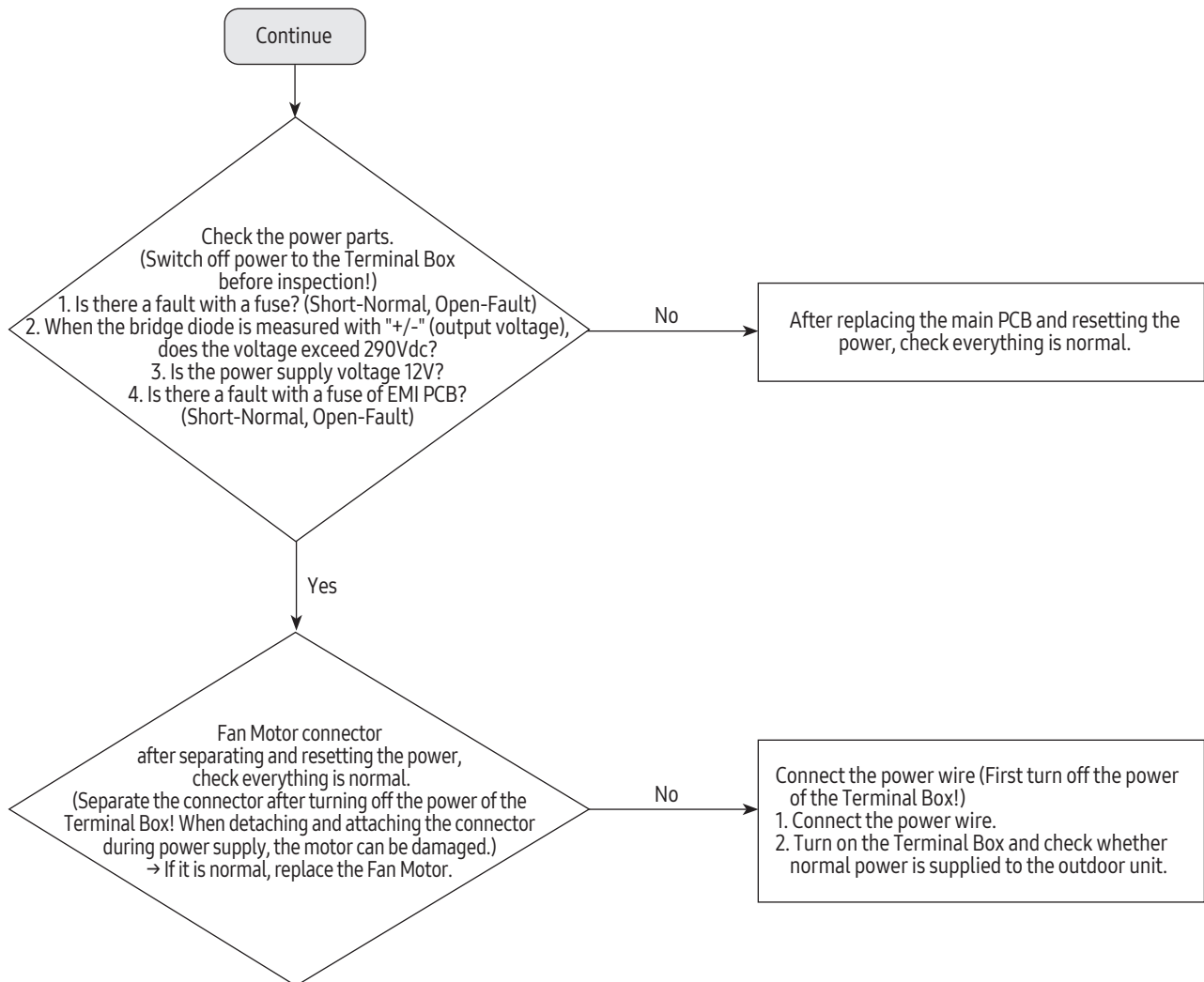

When the outdoor unit power is not ON - Initial Diagnosis: 1-phase products

1. Test items

- 1) Check the power connection of outdoor unit.
- 2) Check the whole connection part of the power wire.
- 3) Check the power on the indoor unit.
- 4) Check the connection of the power wire of the Terminal Block.
- 5) Check the connection of the power wire between the Main↔EMI PBA of the outdoor unit.
- 6) Connect the power wire. (Never forget to turn off the power of the Terminal Box).
- 7) Check the power supply parts. (Check after turning off the power of the Terminal Box!)
- 8) Check everything is normal after separating the fan motor connector and resetting the power.

- 7-segment off.
- Conduct the following test if the mode is not Eco-mode (power saving mode).

(Separate the connector after turning off the power of the Terminal Box! When detaching and attaching the connector during power supply, the motor can be damaged.)

2. Check procedure

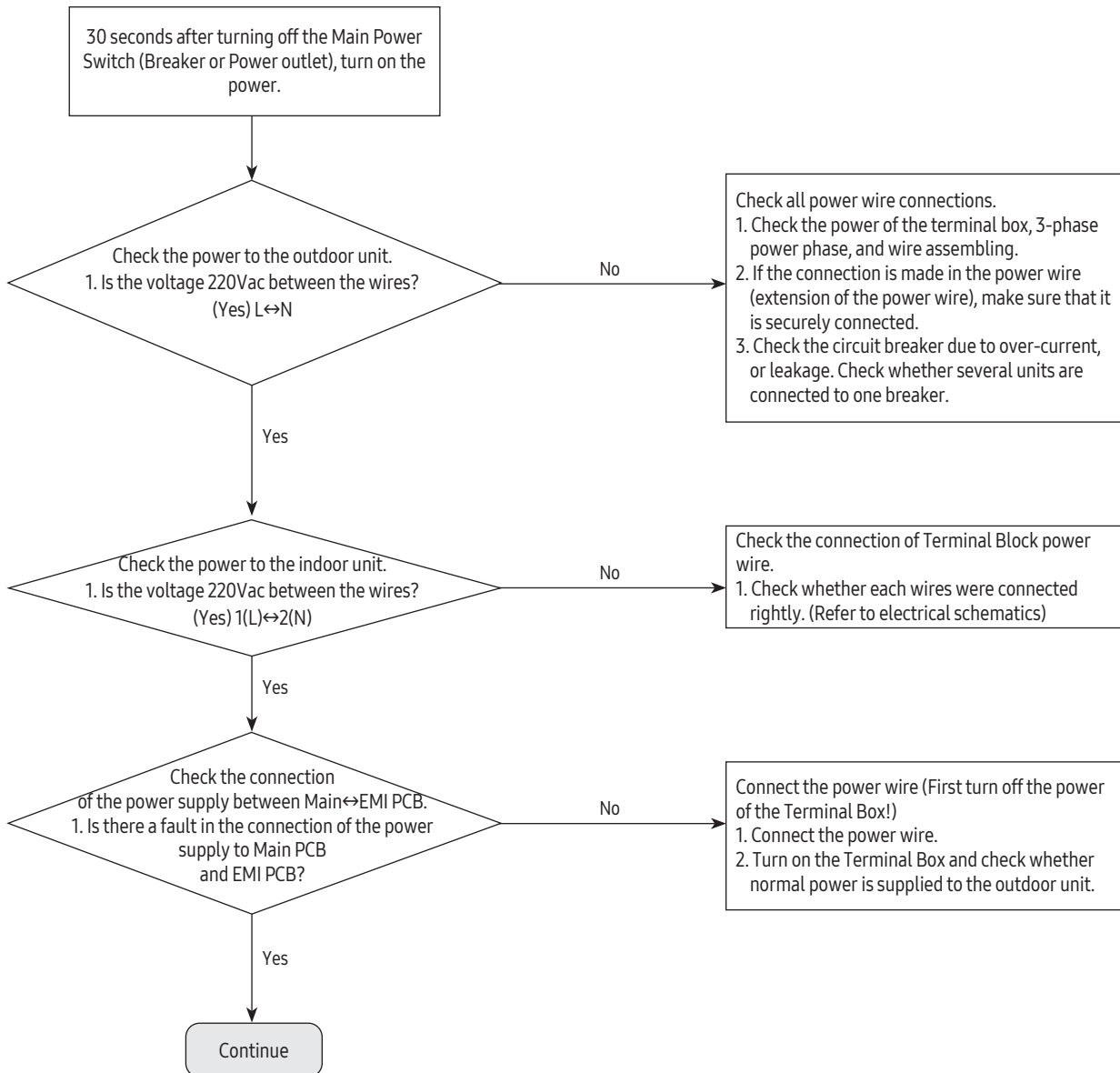

When the outdoor unit power is not ON - Initial Diagnosis: 1-phase products (cont.)

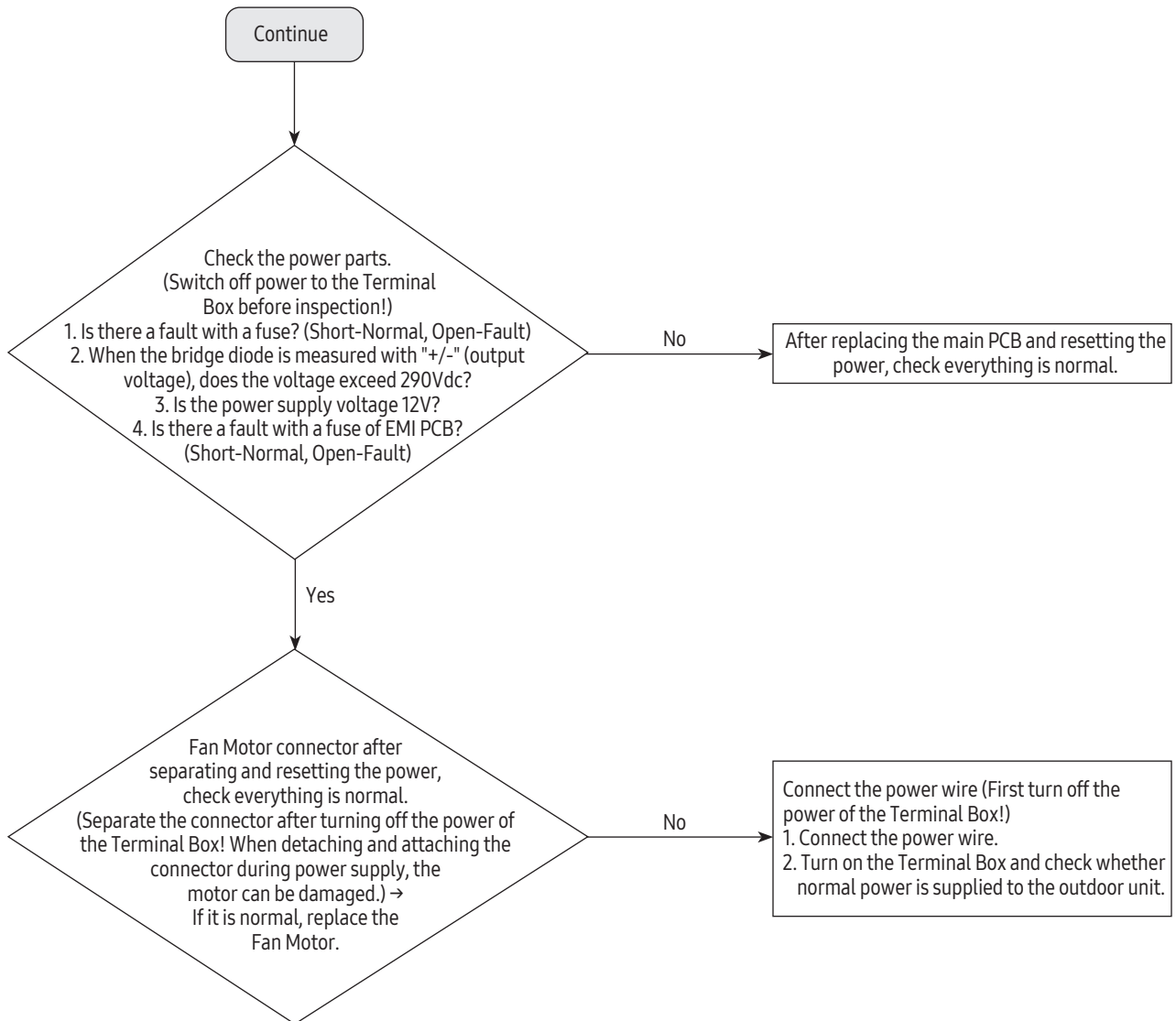

4-3-9 Indoor/outdoor communication error (1min.) (Error Code: E202)

1. Test items
 - 1) Check the communication wire and power wire connection.
 - 2) Check the communication connector connection.
 - CN31 of outdoor unit Main PCB.
 - 3) Check the communication circuit on the PCB.

2. Check procedure

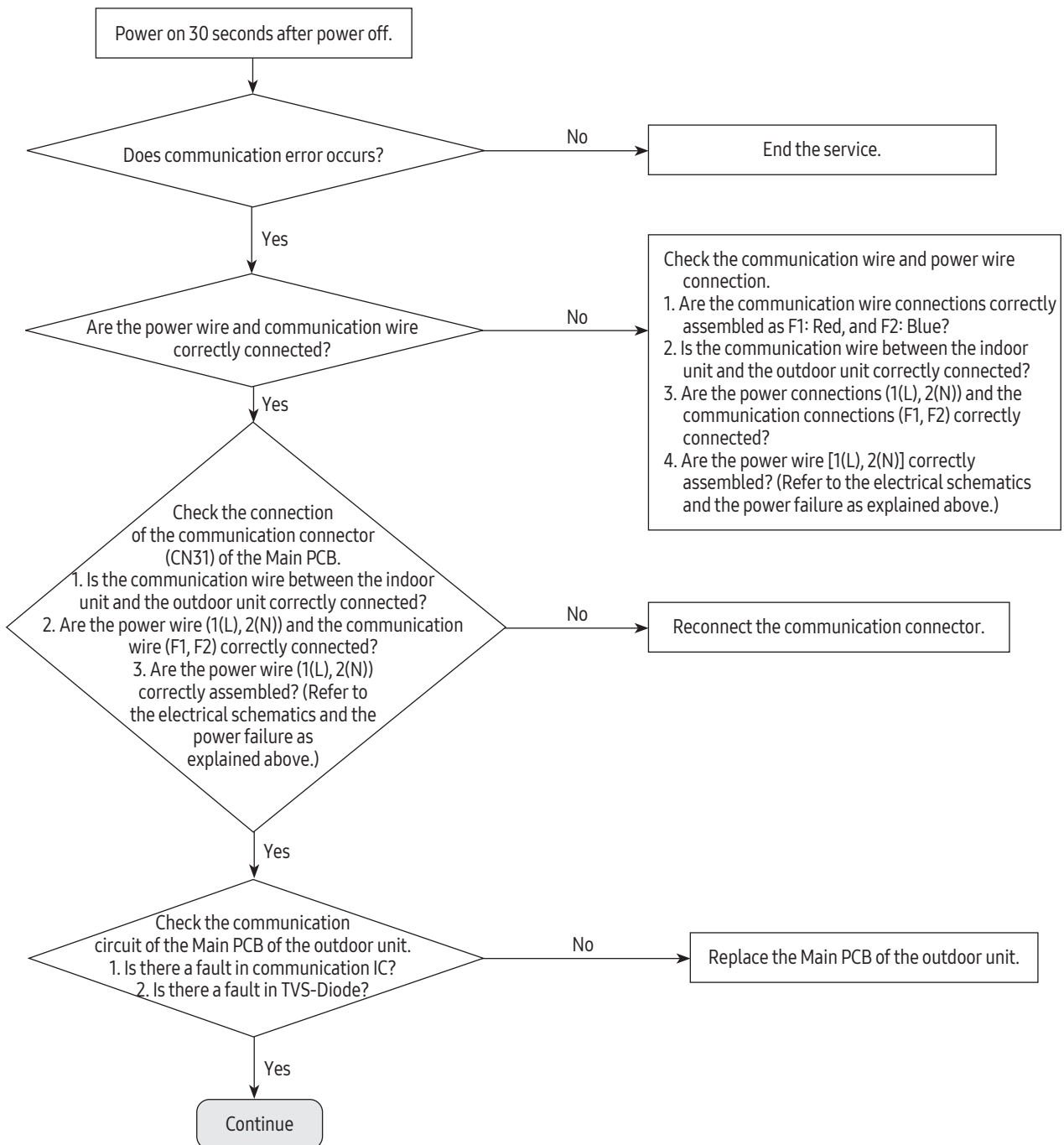

Indoor/outdoor communication error (1 min.) (Error Code: E202) (cont.)

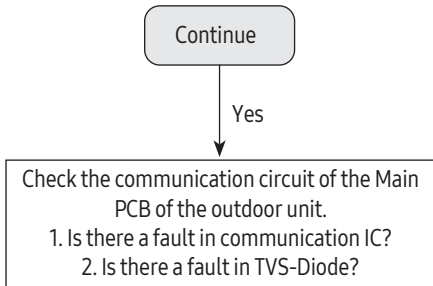

Measuring Part	Communication IC Measuring Part (Circuit Diagram)	Example of Measuring Communication IC	Example of Measuring TVS-Diode
Location			
Measuring Point	#5-GND, #6- Communication A, #7- Communication B, #8-Vcc		

Communication IC Measuring (Port)	Steady-state Measuring Value		Remark
	COM 1(RED)		
#6 - #5	0.9kΩ ~ 1.2kΩ		Measuring after separating the communication connection
#7 - #5	0.9kΩ ~ 1.2kΩ		
#8 - #5	4.7Vdc ~ 5.3Vdc		

TVS-Diode Measuring	Steady-state Measuring Value
Both ends of diode	1kΩ or above

4-3-10 Communication error between outdoor unit INV ↔ MAIN MICOM (1 min.)(Error Code: E203)

1. Test items

- 1) Is power supplied to outdoor unit Inverter PCB?
- 2) Check the power wire connection and fuse.
- 3) Is there a problem in the communication wire connections between the outdoor unit Inverter (CN31) ↔ Main PCB (CN39)?
- 4) Check the communication wire connections.

2. Check procedure

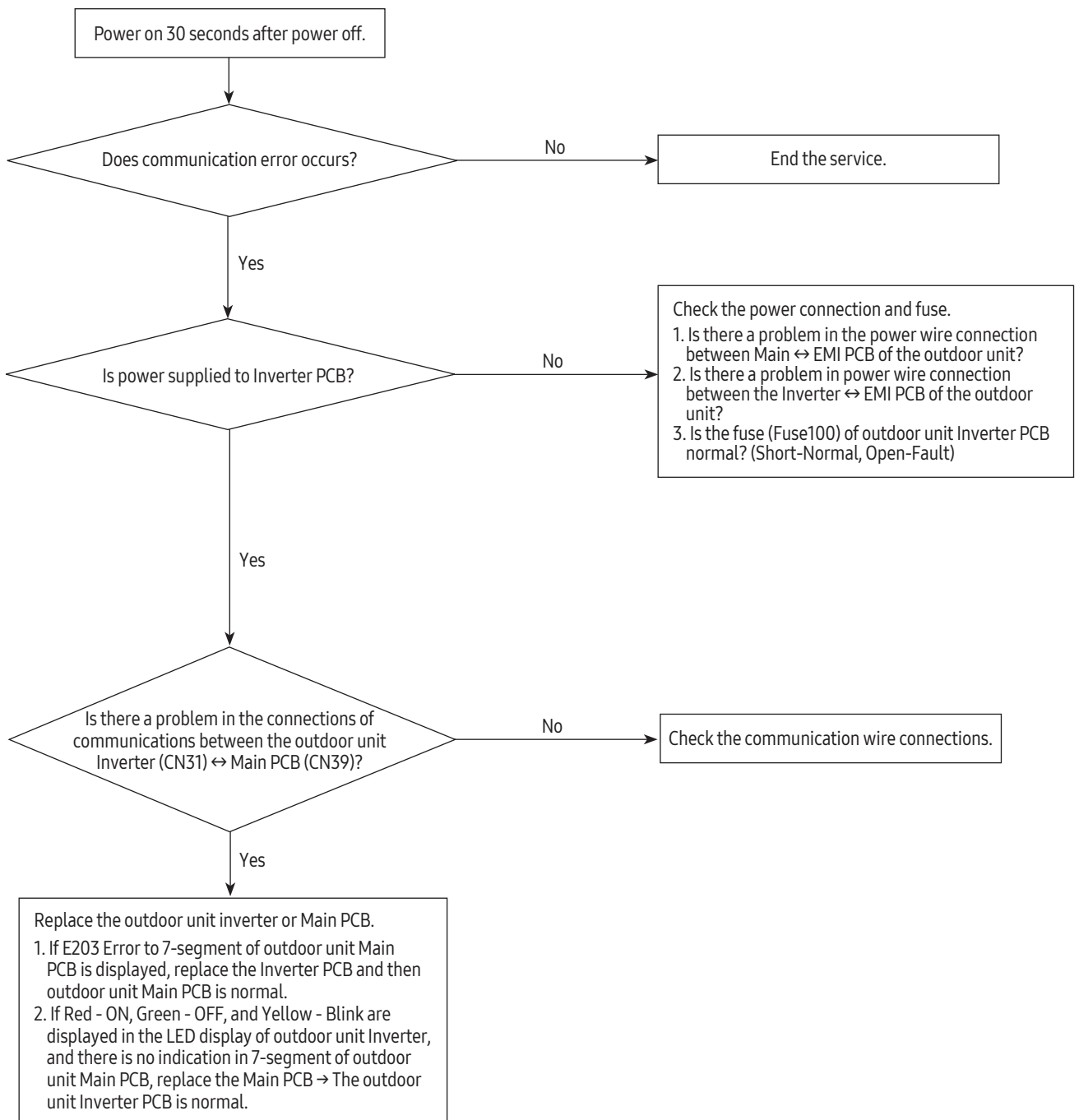

4-3-11 Outdoor sensor error (Error Code: E221, E231, E251, E320)

1. Test items
 - 1) Check the connection of the temperature sensor connector.
 - 2) Check the resistance value of the temperature sensor.
2. Check procedure

Error CODE	Description
E221	Outdoor temperature sensor error
E231	Outdoor temperature sensor error
E251	Outdoor temperature sensor error
E320	Outdoor OLP sensor error

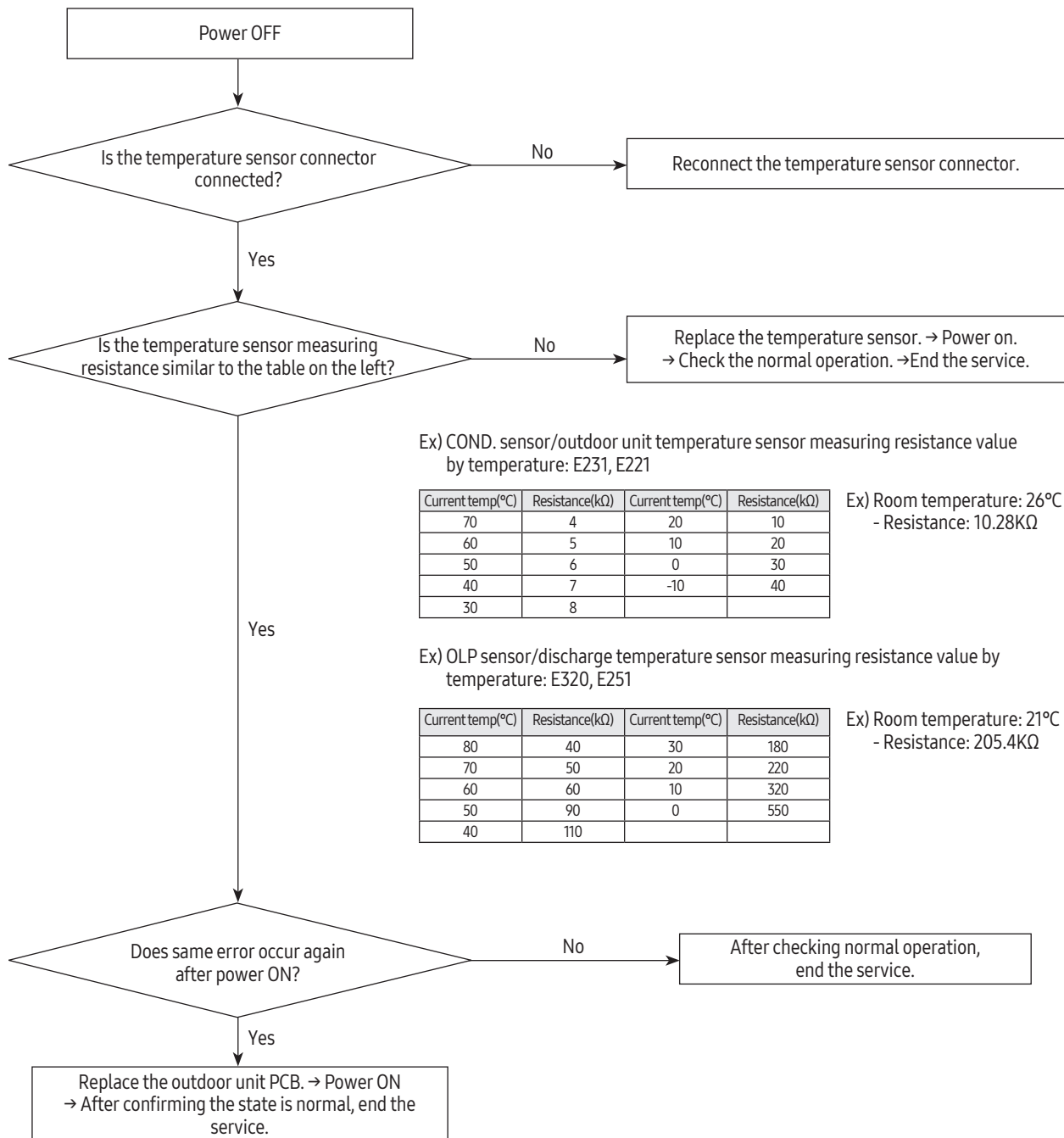

4-3-12 Reverse phase/Loss phase detection (3-phase outdoor unit) (Error Code: E425)

1. When power is on, it checks the power status used for 3-phase power compressor.
When the order of 3-phase L1 (R) – L2 (S) – L3 (T) is changed (Reverse phase) or there is a phase that does not supply power (Loss phase), it will display *E425* and the air conditioner will stop operating. *E425*
 - 1) Check the voltage on L1(R) – L2(S) phase/L1(R) – L3(T) phase/L2(S) – L3(T) phase.
 - 2) When there is any terminal that does not have normal voltage, check the external power of the air conditioner and take appropriate measures.
 - 3) If 3-phase power is normal check the phase of the power wire using 3-phase tester. If it shows reverse phase, change the current power wire connection.
 - 4) After completing above, press reset key (K3) then check the power again.

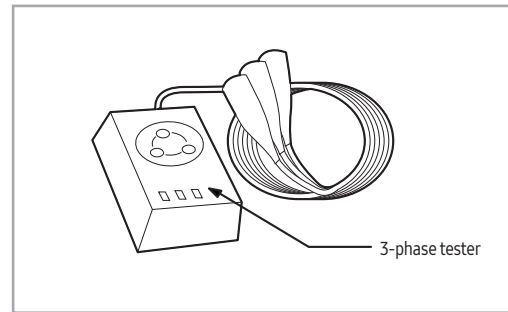

4-3-13 Compressor down due to freezing control (Error Code: E403)

1. Test items

- 1) Check the normal operation of indoor Fan/Motor.
- 2) Check the normal operation of indoor EEV.
- 3) Check the IN/OUT sensor of indoor heat exchanger.
- 3) Check the clogging of indoor air inlet part.

2. Check procedure

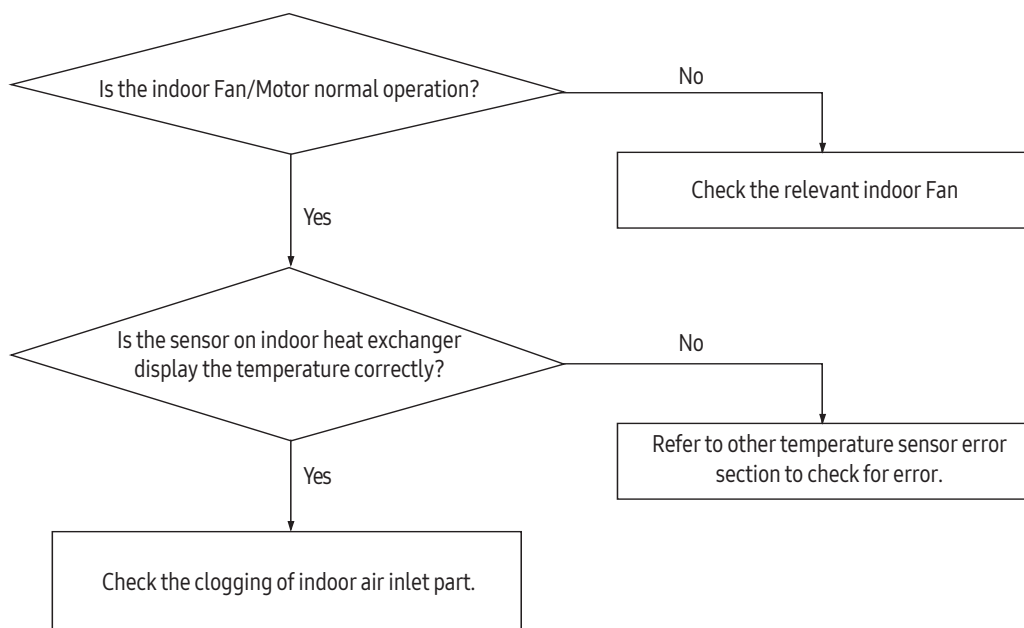

4-3-14 Outdoor unit Fan error (Error Code: E458, E475)

1. Test items

- 1) Check the connection of Fan connectors (CN90, CN91)
- 2) Check the voltage of the fan motor connector in the inverter PBA of the outdoor unit.
- 3) Check the power connection of the outdoor unit Inverter PCB.
- 4) Check the Fan Motor single parts. (Be sure to turn off the power and separate the motor connector after 30 seconds!)

2. Check procedure

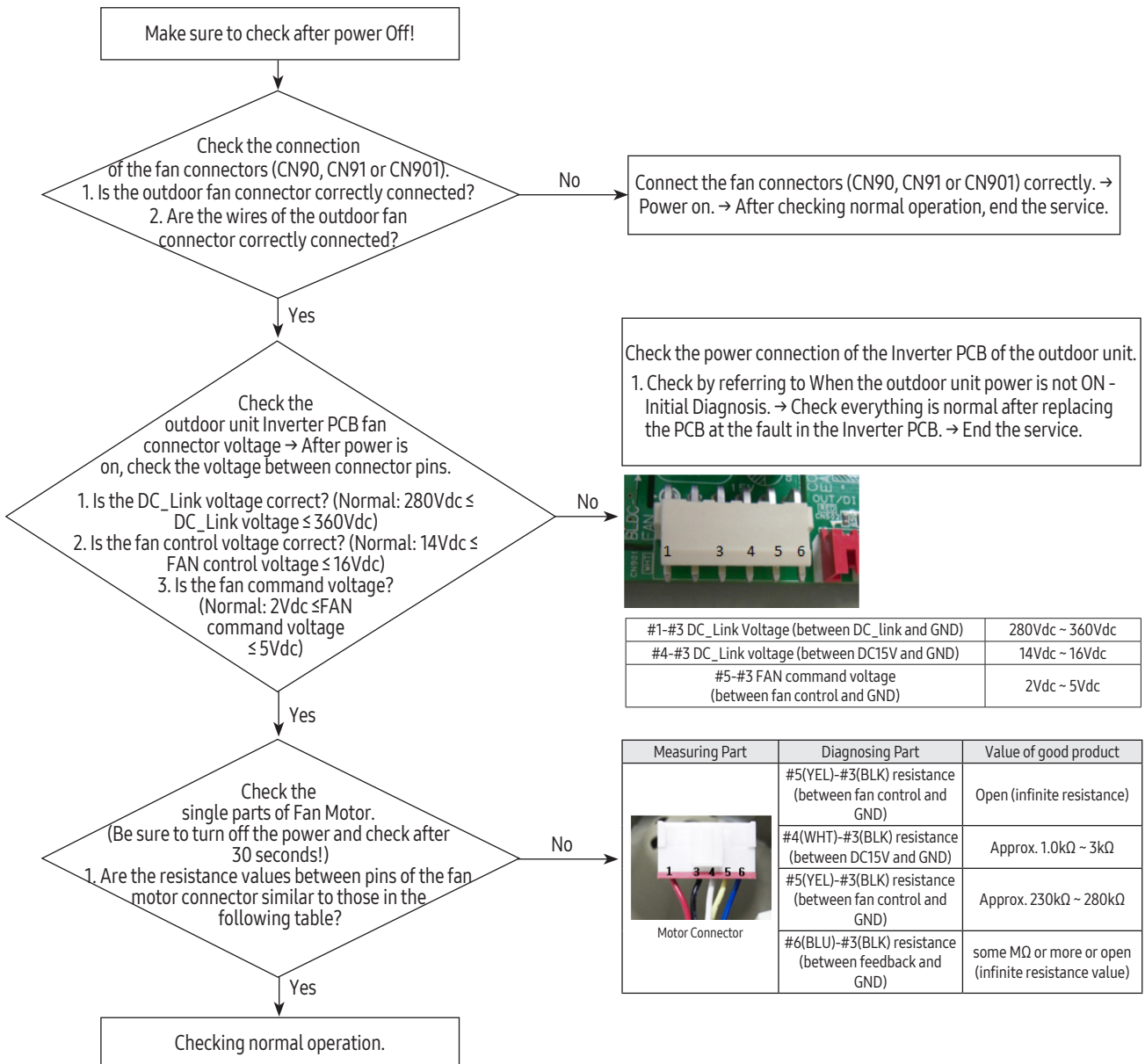

- ※ At least 30 seconds after power is OFF, attach/detach the fan motor connector! → Threatened to cause secondary damage to the motor and the PCB.
- ※ Check the Inverter PCB or Fan Motor single parts and only if there is a fault, replace!
- ※ Do not replace the Main PCB of the outdoor unit relating to the fault in the Fan Motor!
→ If the error is indicated on 7-segment of the Main PCB of the outdoor unit, the Main PCB of the outdoor unit has no fault.
→ In case of a control problem, it is possible to solve with S/W update.

4-3-15 Compressor starting error/rotation error (Error Code: E461, E467)

1. Test items
 - 1) Check the power connection./Check the restart after power reset.
 - 2) Check the compressor and the state of the compressor wire assembling.
 - 3) Check the defective for compressor wire single parts.
2. Check procedure

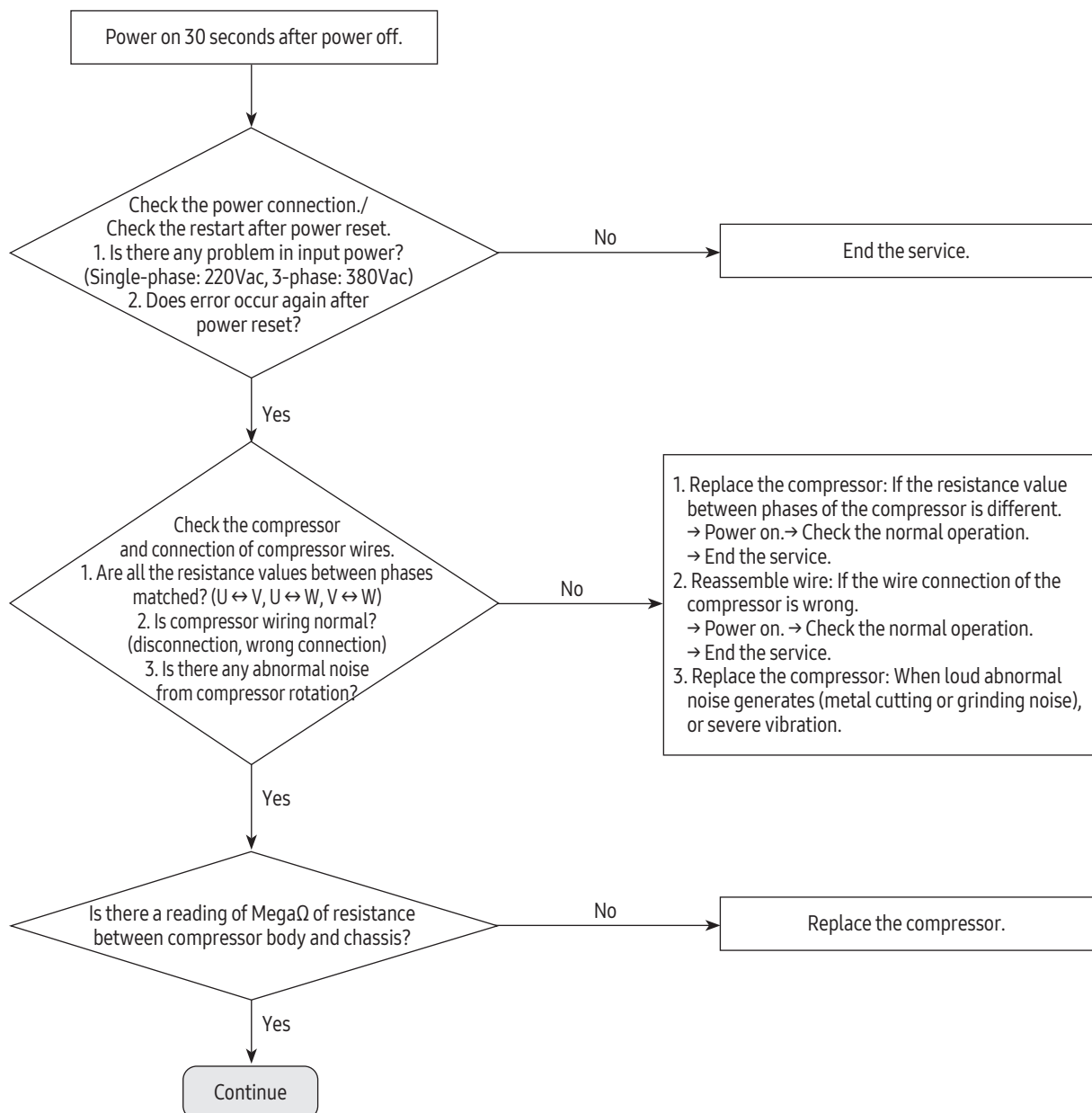

Compressor starting error/rotation error (Error Code: E461, E467) (cont.)

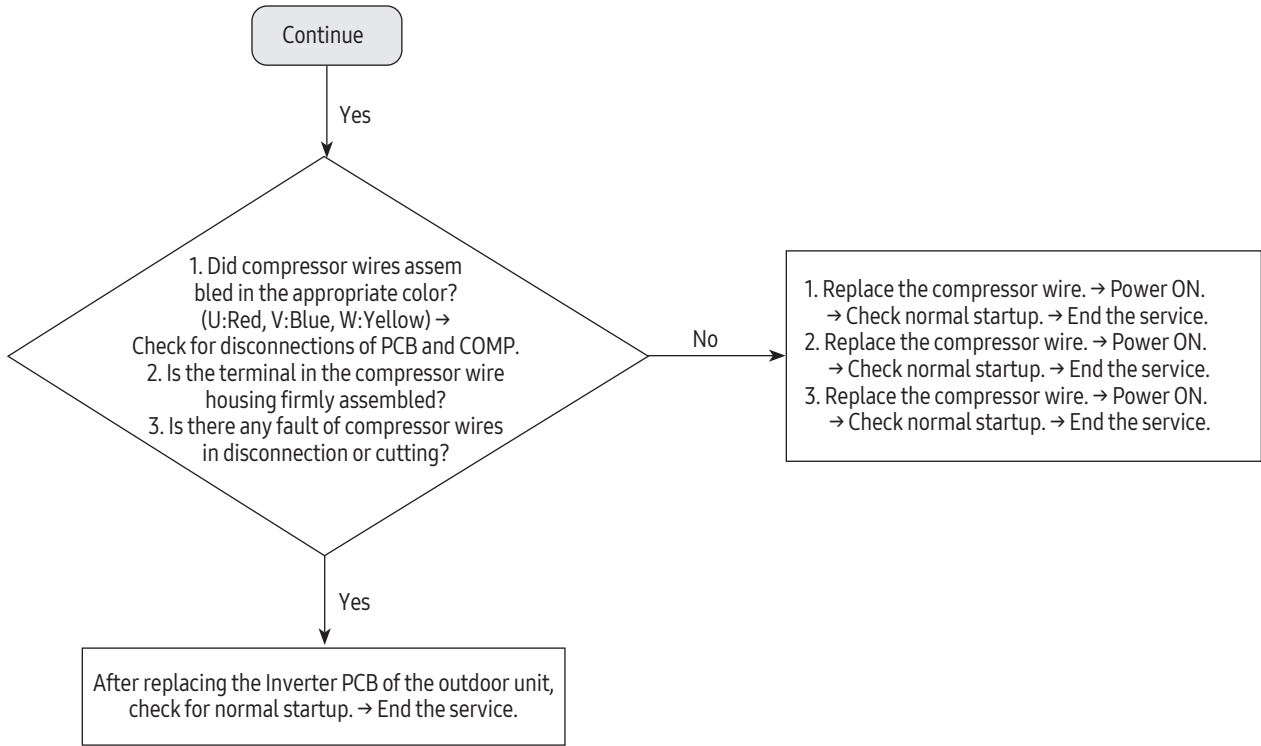

- ※ E461, E467 Error-related, EMI/outdoor unit Main/Indoor unit Main PCB do not replace!
→ This error is related to the compressor and Inverter PCB. (Not related to the above PCB)
- ※ Ensure that the service valve is open!
→ When the service valve is closed, the defects may be caused by differential pressure when starting the compressor.

4-3-16 Full current error/PFC over-current error (Error Code: E462, E484)

1. Test items
 - 1) Check the power connection./Check the restart after power reset.
 - 2) Install outdoor unit and check environment.
 - Check for wire disconnection related to outdoor unit Inverter PCB and check the installation environment.
 - 3) Check the indoor unit installation environment.
 - 4) Check the opening of service valve.
2. Check procedure

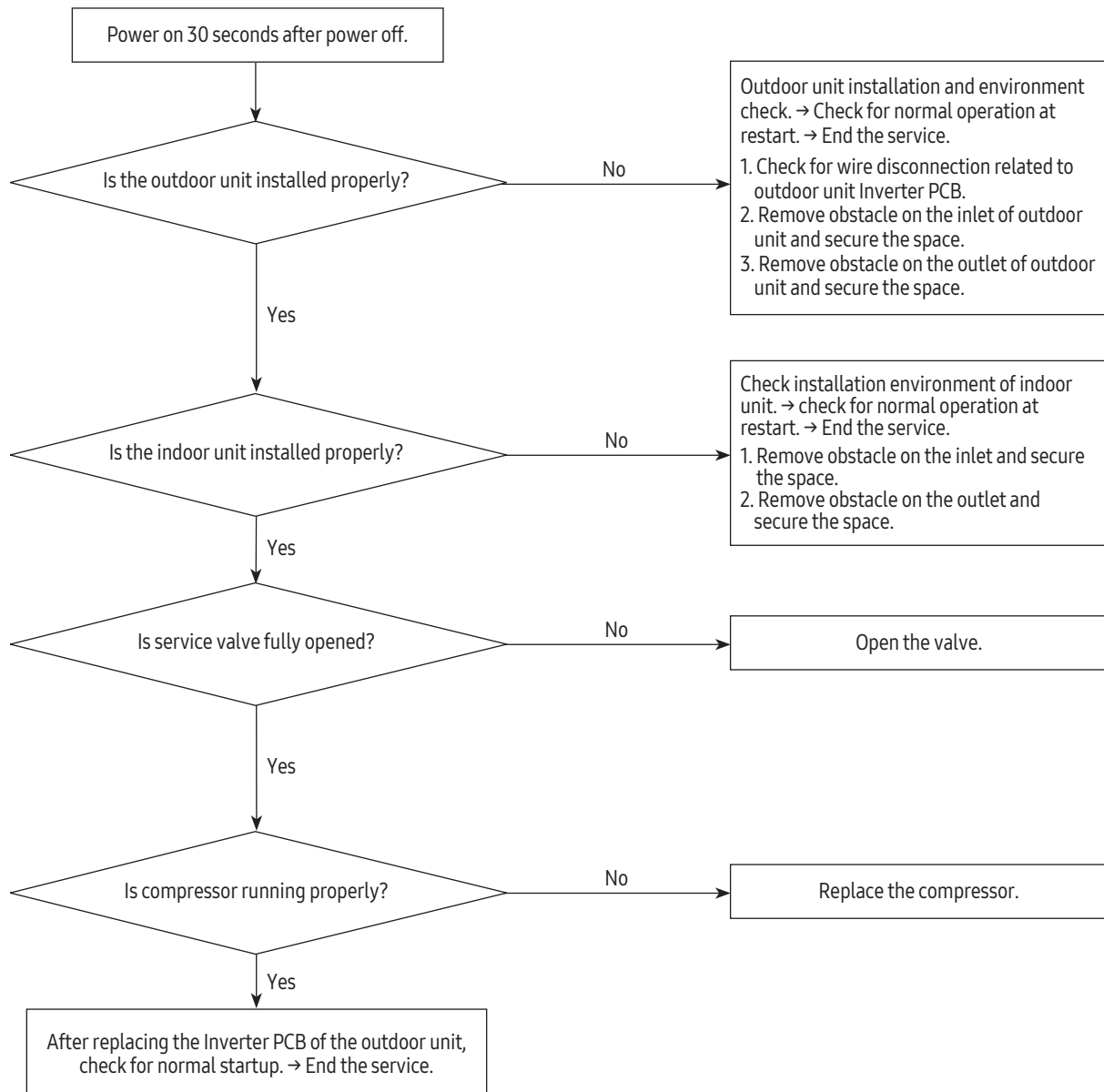

4-3-17 IPM over current error (Error Code: E464)

1. Test items
 - 1) Check the power connection./Check the restart after power reset.
 - 2) Install outdoor unit and check environment.
 - Check for wire disconnection related to outdoor unit Inverter PCB and check the installation environment.
 - After having installed several units, please check that communication wires are not interchanged with piping.
 - 3) Check the indoor unit installation environment.
 - 4) Check the opening of service valve.
 - 5) Check the status of compressor assembly and wiring.
 - 6) Check the defective for compressor wire single parts.

2. Check procedure

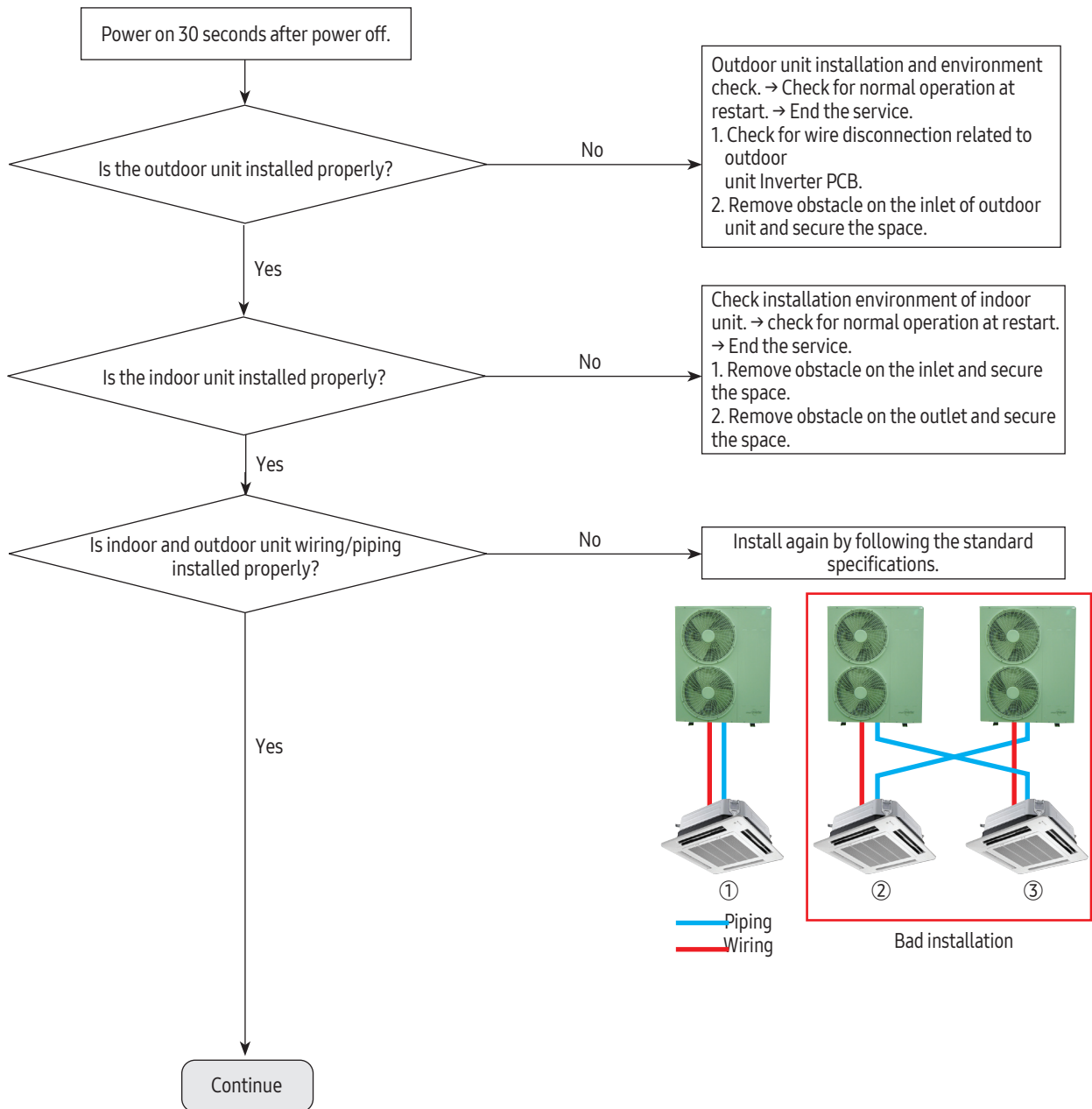

IPM over current error (Error Code: E464) (cont.)

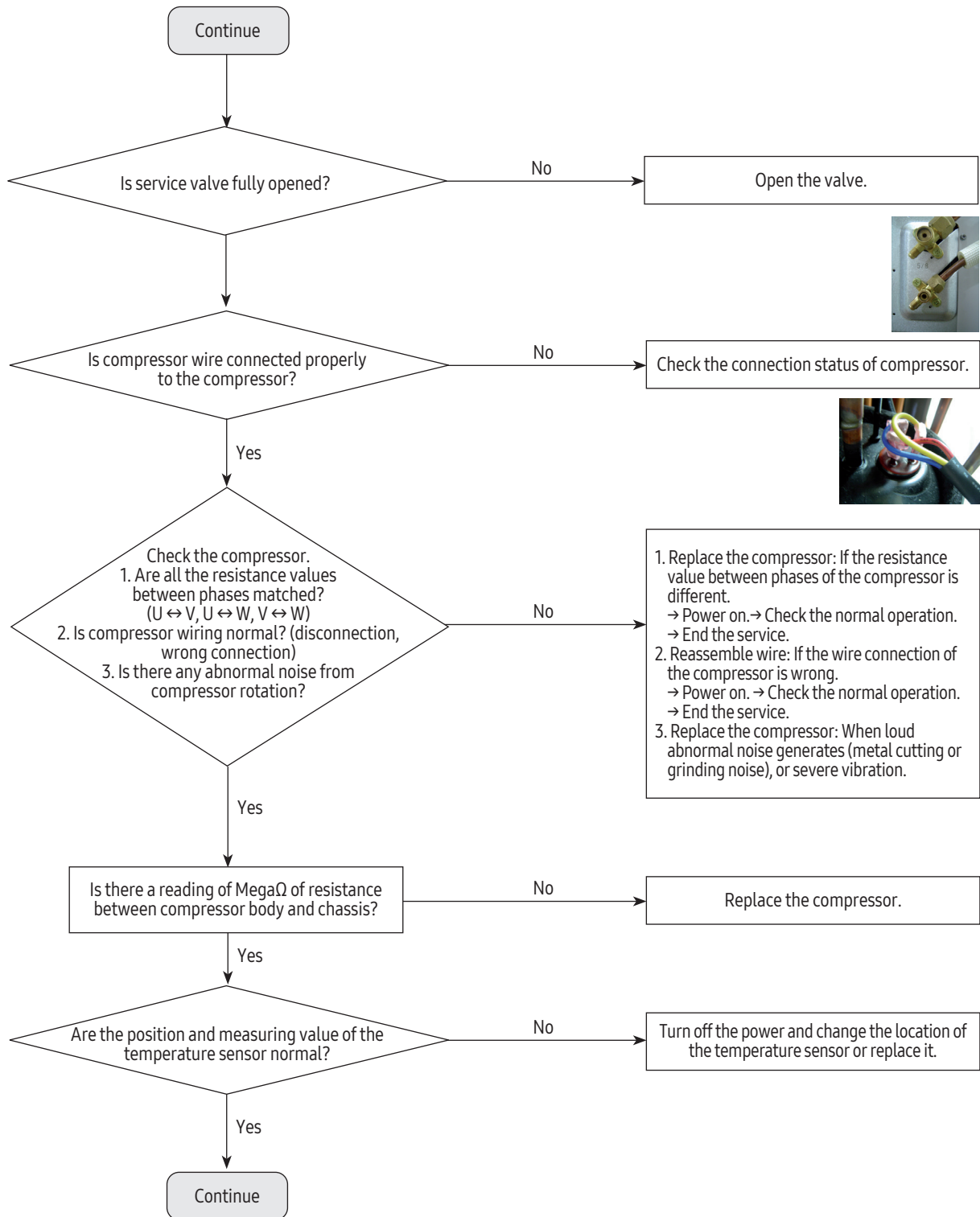

IPM over (Over Current) error (Error Code: E464) (cont.)

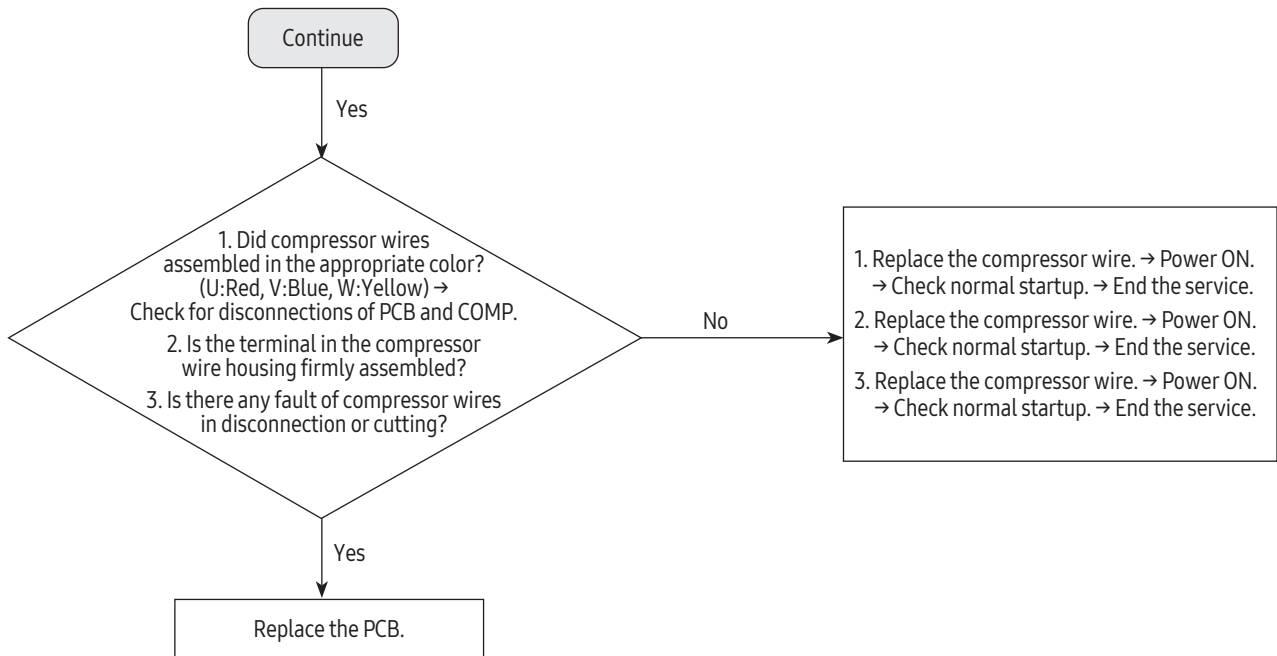

- ※ E46 Error-related, EMI/outdoor unit Main/Indoor unit Main PCB do not replace!
→ This error is related to the Inverter PCB. (Not related to the above PCB)
- ※ Ensure that the service valve is open!
→ When the service valve is closed, the defects may be caused by differential pressure when starting the compressor.

**4-3-18 DC LINK over-current/low-voltage error (Error Code: E466)
H/W DC_Link Over Voltage Error (Error Code: E483)
AC Input Voltage Sensor Error (Error Code: E488)**

1. Test items

- 1) Check the power connection./Check the restart after power reset.
→ Is there a fault in input power? (Single-phase: 220Vac, 3-phase: 380Vac)
→ Does error occur again at operation after power is reset?
- 2) Check the connection of the power, and check whether the jointed power connection exists.
→ After having installed several units, please check that communication wires are not interchanged with piping.
- 3) Check the reactor and its connecting wires.
- 4) Check the fuses of EMI PBA.
- 5) Check the Terminal Block and Power Terminal Box and the wire assembly.

2. Check procedure

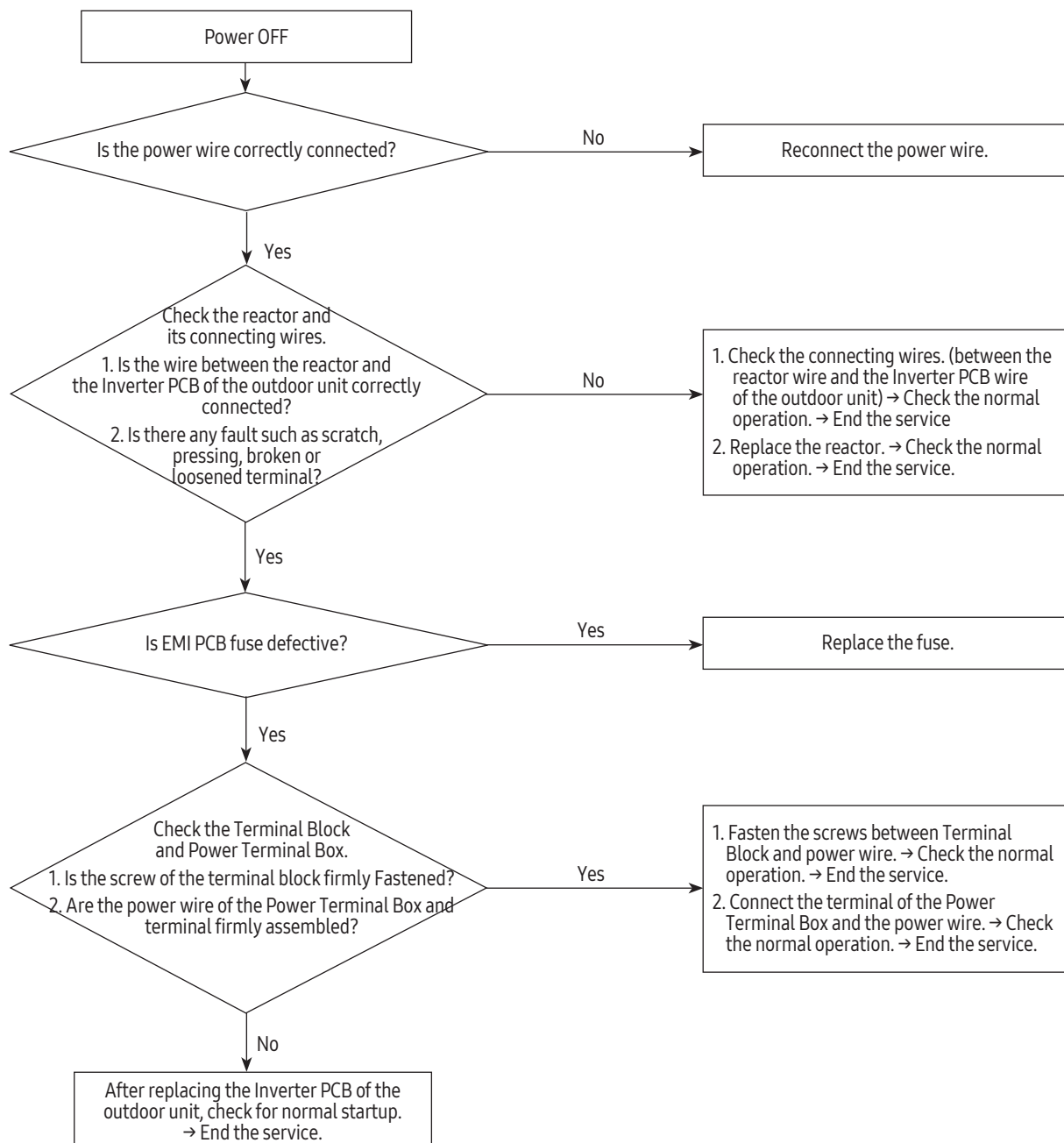

4-3-19 Gas leakage error (Error Code: E554)

1. Test items

- 1) Check the power connection./Check the restart after power reset.
 - Is there a fault in input power? (Single-phase: 220Vac, 3-phase: 380Vac)
 - Does error occur again at operation after power is reset?
- 2) Check the compressor and the state of compressor wire assembling.
- 3) Check the outdoor unit installation environment.
 - Check for disconnection of the wires regarding the Inverter PCB of the outdoor unit and check the installation environment.
 - At the site where several units were installed at the same time, check whether communication wire and pipes have been wrongly connected!

2. Check procedure

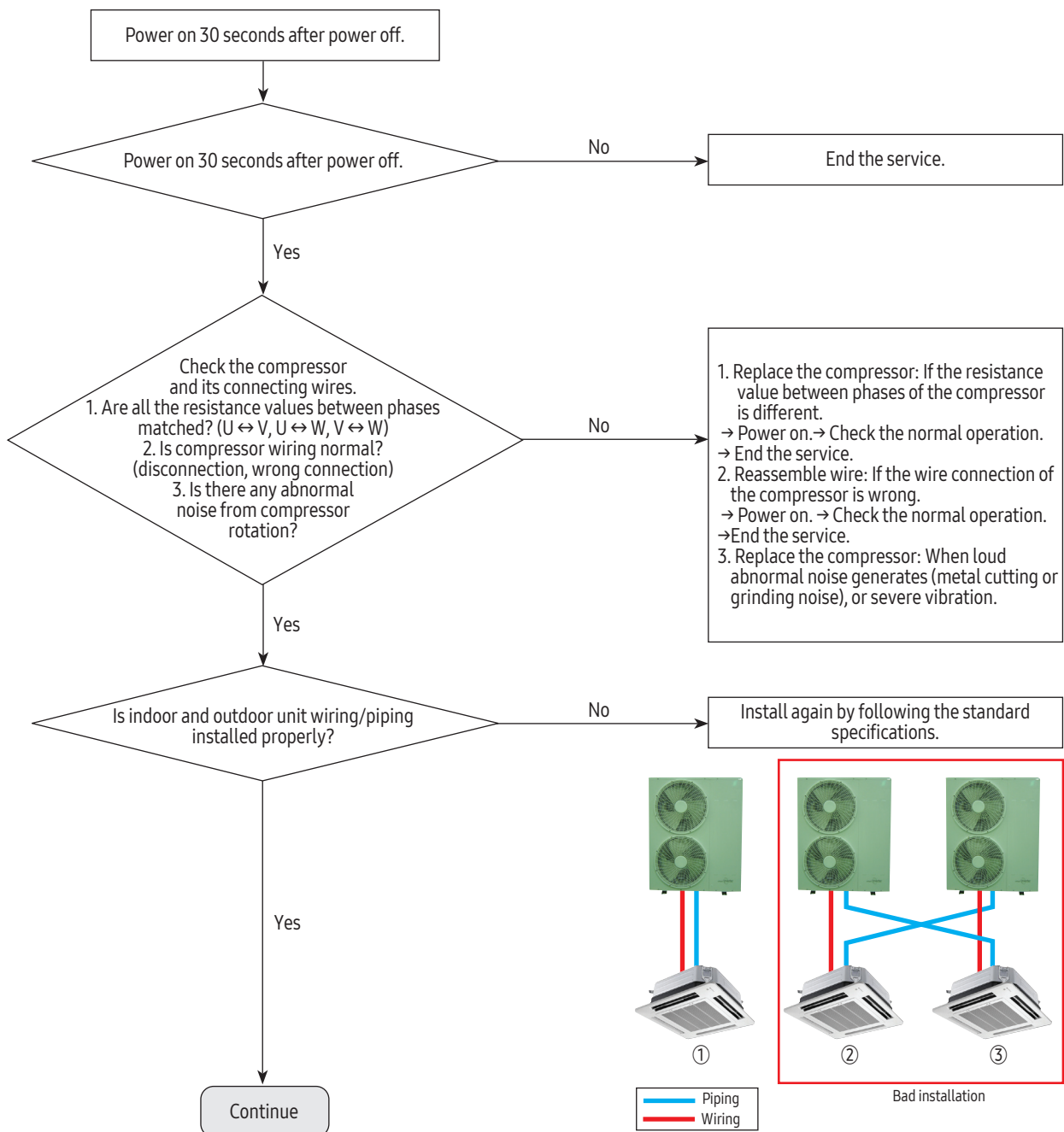

4-3-20 Outdoor unit High Pressure Switch Error (E507)

1. Check items
 - 1) Is the high pressure switch connected correctly?
 - 2) Is there any problem with service valves?
 - 3) Is the air circulation of indoor and outdoor heat exchange unit normal?
 - 4) Is the installation piping length and refrigerant amount of the product appropriate?
2. Check procedure

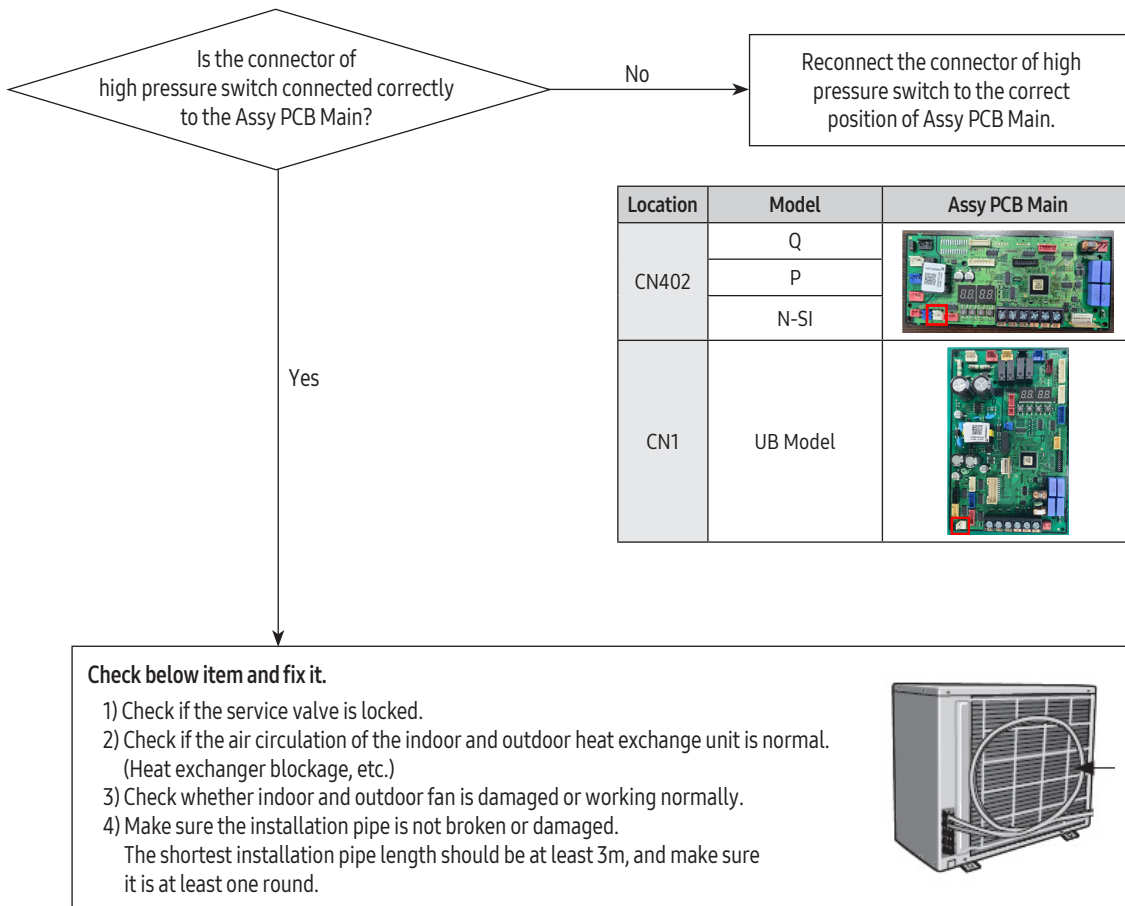

Gas leakage error (Error Code: E554) (Cont.)

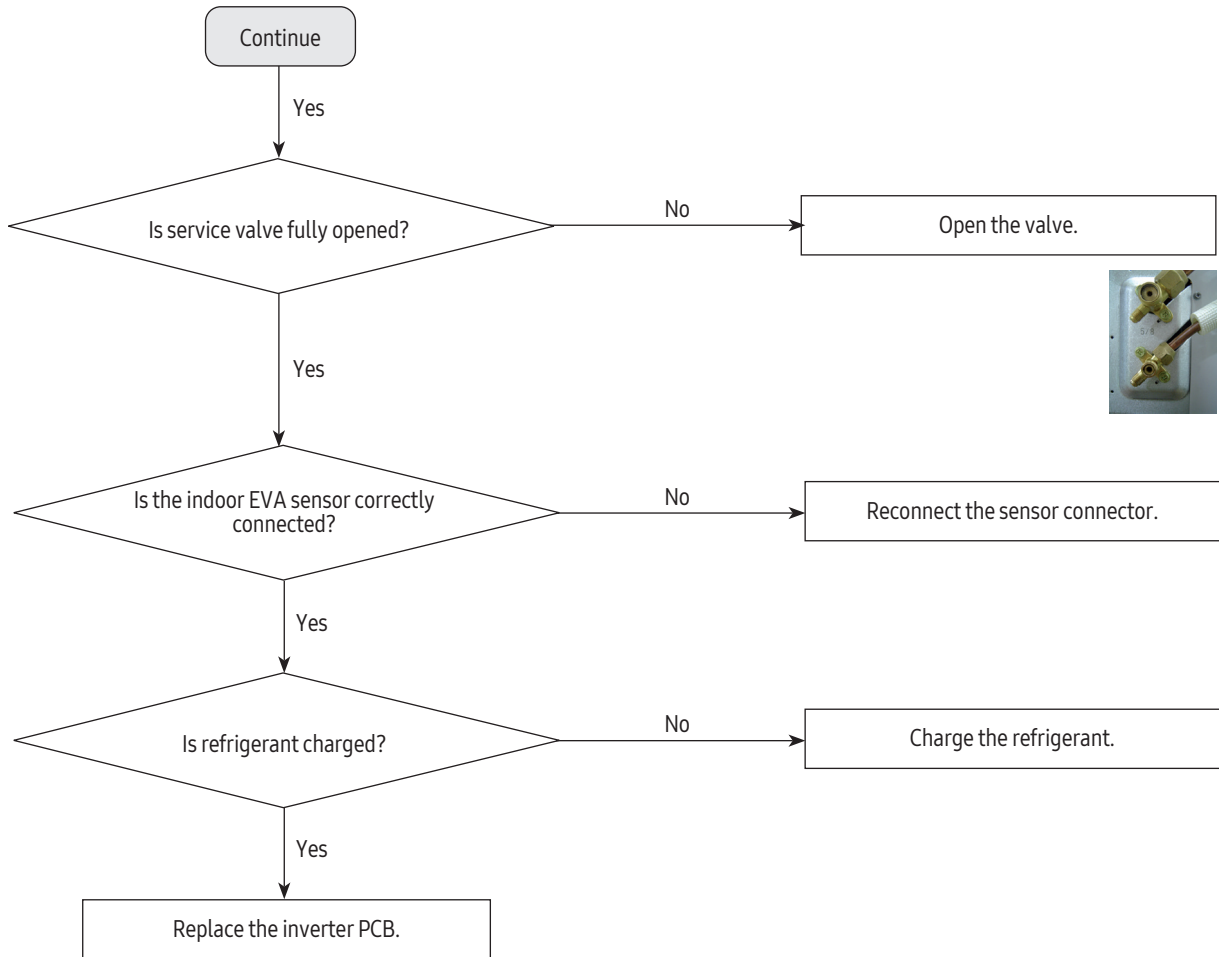

4-3-21 Pipe blockage error (Error Code: E422)

1. Test items
 - 1) Check the open state of the outdoor unit service valve.
 - 2) Check the connection of the pipe.
 - 3) Check the operation of the EEV.
 - 4) Check the refrigerant leakage.
 - 5) Check the connection of the indoor unit PBA EVA sensor.
 - 6) Check the fault in the indoor unit EVA sensor.
2. Check procedure

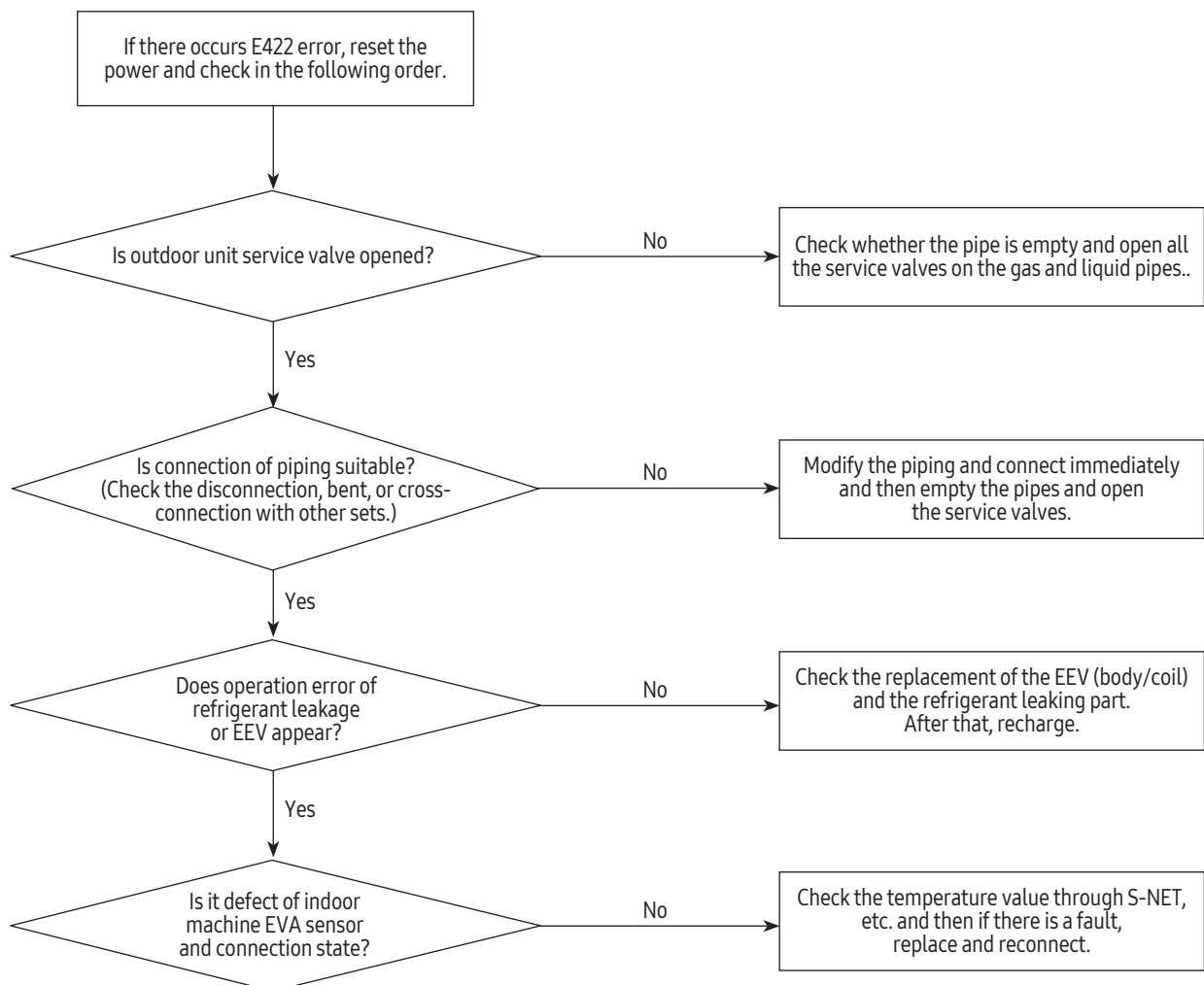

4-3-22 Smart install mode was not carried out (Error Code: E508)

Smart install mode?

When installing the air conditioner the first time, the installation status and fault status and performance of the product is a self-diagnostic function to determine comprehensively.

(The corresponding model is necessarily the general operation can be carried out when the smart install mode.)

Installation procedures of smart install mode

(1) Check the installation status of air conditioner.

- ▶ Check the power wire, communication wire, power connection, service valve opening, additional amount of refrigerant.
- ▶ When supplying power upon installation, a warning (error) of not having run in the installation smart install mode is displayed and the product will not run properly.

Model	Indoor unit	Outdoor unit
360 Cassette	Red lights up	E508

(2) Enter the smart install mode.

- ▶ Enter of the outdoor unit: Press for at the same time 5 seconds K1, K4 switches.
- ▶ Enter of the remote control: Press for at the same time 4 seconds [Power] + [Set] + [Mode] buttons.
- ▶ The progress status of installation smart install mode is shown in "00~99"(%).
- ▶ The smart install may take about 10 minutes.

Model	Indoor unit	Outdoor unit
360 Cassette	It is blinking in sequence. (Ice blue → Yellow green → Blue → Red → Ice blue)	"F" "F" "r" "d" After lasting for 3 minutes "F" "F" "00~99" display.

(3) The installation smart install mode is complete.

- ▶ Success in the installation smart install mode: The unit will enter a general operation standby mode upon blinking to show a success.

Indoor unit	Outdoor unit
Indicator light of main unit switches off.	"F" "F" "r" "F" After blinking for 10 seconds. It will enter the general operation stand by mode.

- ▶ Smart Install failure: Error code blink

※ In the event of Error Error code reference, please carry a house from scratch after an action mode for the Smart Install Error.

Precautions

- ▶ When needing to have additional piping before entering the installation smart install mode, charge refrigerant additionally according to the manual. At this time, it is possible to run the cooling test (K2 switch once) and heating test (K1 switch once).
 - ▶ When the installation smart Install mode is not run, the remote control and main unit button will not work.
[E508 (Smart install mode was not carried out) error displayed.]
 - ▶ The installation smart install mode operation may be interrupted by pressing the K3 switch.
[Display the E508 (Smart install mode was not carried out) error upon interruption.]
 - ▶ While running in the installation smart install mode, the installation smart Install mode operation may not be interrupted even by pressing the K1 or K2 switch.
 - ▶ While running in the installation smart install mode, the system status information may be checked by pressing the K4 switch.
 - ▶ When pressing the K1 and K4 switches for 5 seconds upon successfully running in the installation smart install mode, the system will run the installation smart install mode again.
 - ▶ When having an error in the installation smart install mode, operation in the installation smart install mode may be interrupted.
Please run the installation smart install mode again upon taking appropriate action for the error.
(Refer to troubleshooting)
 - ▶ When the installation smart install mode is not completed successfully even after resolving all the errors, the unit will not work, displaying an error code of E508 (Smart install mode was not carried out). Upon resolving the problem, try to complete running the installation smart install mode.
- ※ Displayed E508 is not a malfunction, it is indication that did not carried out the smart Install mode after air conditioner installation.

4-3-23 Others

1. **EEPROM option error (E163): Reset the options.**
2. **Temperature fuse error: E198**
 - If the Terminal Box temperature rise fuse is disconnected, replace the PCB.
 - Check the wiring connector of temperature fuse.
3. **Current sensor error: Upload EEPROM to the Main PCB of the outdoor unit.**
 - After checking for normal operation of PCB, replace the inverter PCB.
4. **Compressor Vlimit error: E465**
 - If the compressor is abnormally run, replace the compressor and then ensure that it works normally.
 - If the compressor is normally run, check the assembling between the heatproof plate and the Inverter PCB and then if there is no abnormality, replace the Inverter PCB.
5. **DC link voltage sensor error: E469**
 - Error occurs when DC LINK value is not normal (DC LINK VOLTAGE: 280~320V)
 - Check the value of DC link when error occurs and check the reactor disconnection
6. **EEPROM read/write error: E470**
 - Error occurs when there is no EEPROM data in the set.
 - Check the model name and insert EEPROM for corresponding model or load the EEPROM data.
7. **Input current sensor error: E485**
 - Detect the input sensor while the set is in stop status to check if there's any problem.
 - When error occurs, turn on/off the power for number of time and if same error occurs while the power is off, replace the Inverter PCB.
8. **OTP error: E471**
 - Upload EEPROM to the Main PCB of the outdoor unit.
9. **Capacity inconsistency error: E556**
 - Check the model name between the outdoor and indoor unit and re-enter the option code to the indoor unit.
10. **3-phase power wire disconnection: E424**
 - Check for disconnection of the 3-phase (open) power wire, and check the disconnected EMI PBA fuse.
11. **Outdoor unit freezing detection (at the stop of the compressor): E403**
Outdoor overload protection control (at the stop of the compressor): E404
 - Check whether the fan and the motor operate normally.
 - Check the operation of EEV.
 - Check the temperature sensor of the indoor unit heat exchanger.
 - Check the indoor unit inlet blockage.
12. **Outdoor unit compressor discharging temperature protection control: E416**
 - Check for lack of refrigerant.
 - Check the blockage of the solenoid valve.
 - Check the malfunction of the exhaust temperature sensor.
 - Check the EEV.
13. **Error of impossibility to operate heating at outdoor temperature exceeding 30°C: E440**
Error of impossibility to operate cooling at outdoor temperature of -5°C or under: E441
 - It is not the error code in the product and it is a specification to protect the product by limiting the temperature scope of use.
 - Use by referring to the temperature scope of use on the product manual, etc.

14. OLP overheating and compressor stop: E463

- Check the opening of the sub valve.
- Check the amount of the cooling water.
- Check the OLP sensor.

15. Current sensor error: E468

- Check the EEPROM data.
- Check the PCB operation.

16. IPM (IGBT Module) or PFCM temperature sensor error: E474**IPM overheat error for outdoor unit inverter compressor: E500**

- Check whether IPM is correctly assembled on the heatproof plate.
- Check whether the inlet is blockage.
- If there is a defect, replace the IPM.

17. Mismatching indoor unit and outdoor unit error: E563

AC026/035/052RNJDKG:

- AC***RNJDKG models are not available to install DPM. Do not install DPM.

The other models:

- Check the indoor unit cycle option code.

5. PCB Diagram and Parts List

5-1 Indoor Unit

5-1-1 MAIN PCB

- 1Way CST: AC026/035RN1DKG
- 4Way CST: AC052/071/100/120/140RN4DKG
- Ceiling: AC052/071RNCDKG
- Mini 4Way CST: AC026/035/052/071RNNDKG
- ▶ Type A

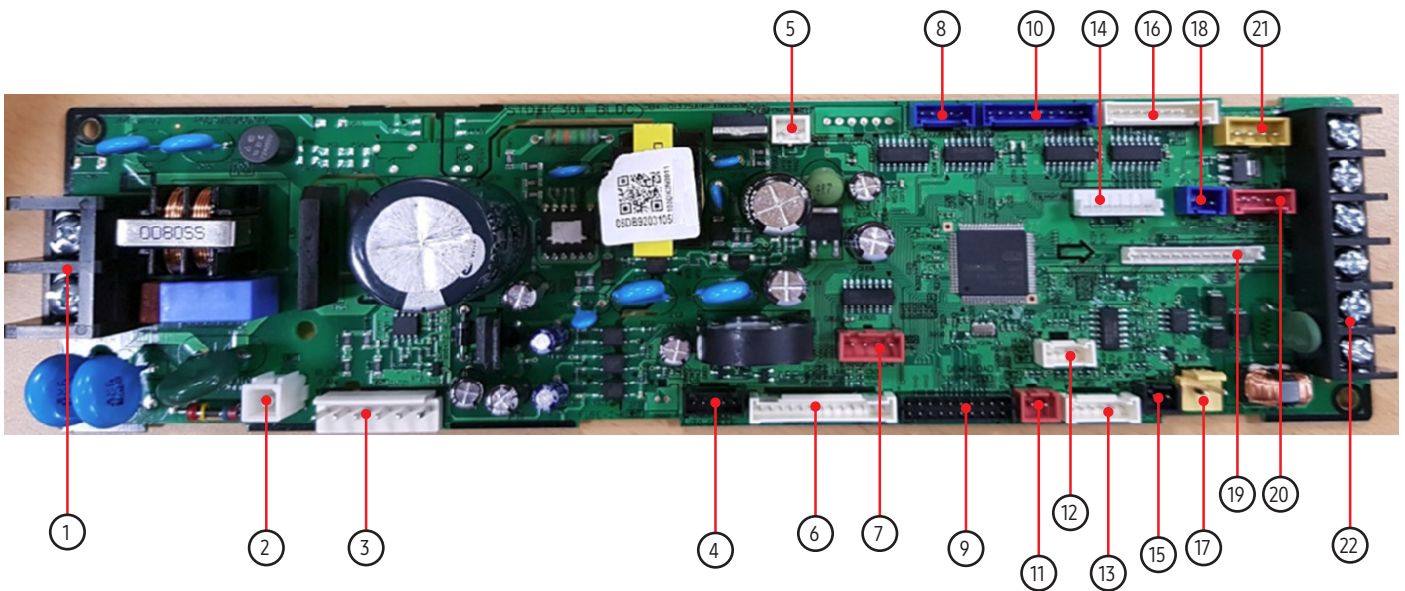

This Document can not be used without Samsung's authorization.

<p>① TB101-AC POWER #1: AC POWER (L) #2: AC POWER (N)</p>	<p>② CN101-EARTH #1: EARTH</p>	<p>③ CN701-BLDC MOTOR #1: DC310V #3: GND #4: DC15V #5: FAN RPM #6: RPM FEEDBACK</p>	<p>④ CN809-AUTO GRILLE #1: DC12V #4: REMOCON OUT #5: GND</p>	<p>⑤ CN412-ROOM SENSOR #1: ROOM SENSOR #2: GND</p>
<p>⑥ CN501-DISPLAY #1: DC12V #2: LED_0 #3: LED_1 #4: LED_2 #5: LED_3 #6: LED_4 #7: LED_5 #8: REMOCON SIGNAL OUTPUT #9: AUTO SWITCH #10: REMOCON SIGNAL INPUT #11: GND #12: DC5V #13: GND</p>	<p>⑦ CN81-COMP/ERROR MONITOR #1: DC12V #2: ERROR OUT (GND) #3: DC12V #4: COMP/OPER. OUT (GND)</p>	<p>⑧ CN807-LOUVER5 #1: DC12V #2~#5: LOUVER SIGNAL</p>	<p>⑨ CN301-DOWNLOAD</p>	<p>⑩ CN806-LOUVER3/4 #1: DC12V #2~#5: LOUVER SIGNAL #6: DC12V #7~#10: LOUVER SIGNAL</p>
<p>⑪ CN83-EXT CTRL #1: GND #2: EXTERNAL CONTROL SIGNAL</p>	<p>⑫ CN414-HUMIDITY SENSOR #1: DC5V #2: GND #3: THERMISTOR SENSOR #4: HUMIDITY SENSOR</p>	<p>⑬ CN413:THERMISTOR #1: EVA-IN SENSOR #2: GND #3: EVA-OUT SENSOR #4: GND #5: DISCHARGE SENSOR #6: GND</p>	<p>⑭ CN201-EEPROM #1: GND #3: DC5V #4: EEPROM_SELECT #5: EEPROM_SO #6: EEPROM_SI #7: EEPROM_CLK</p>	<p>⑮ CN411-FLOAT SWITCH #1: FLOAT SWITCH SIGNAL #2: GND</p>
<p>⑯ CN805-LOUVER1/2 #1: DC12V #2~#5: LOUVER SIGNAL</p>	<p>⑰ CN103-DRAIN PUMP #1: DRAIN PUMP (DC12V) #2: GND</p>	<p>⑱ CN804-VENTILATOR #1: DC12V #2: VENT SIGNAL OUTPUT (GND)</p>	<p>⑲ CN311-2WIRED REMOCON #1: DC12V #2: COM2_PTCTRL_MICOM #3: COM2_VCHECK_A #4: COM2_VCHECK_B #5: COM2_MICOM_AD #6: Vcc_PS_OUT(DC5V) #7: COM2_ENABLE #8: COM2_C (COM2_F3) #9: COM2_D (COM2_F4) #10: COM2_Tx #11: COM2_Rx #12: GND</p>	<p>⑳ CN401-HUMAN SENSING #1: DC12V #2: MAIN-HUMAN SENSOR COMM (TXD) #3: MAIN-HUMAN SENSOR COMM (RXD) #4: GND</p>
<p>㉑ CN801-SPI #1: GND #2: GND #3: SPI SIGNAL (DC12V)</p>	<p>㉒ TE04-COMMUNICATION #1: COM1 (F1) #2: COM1 (F2) #3: V1 (DC12V) #4: V2 (GND) #5: COM2 (F3) #6: COM2 (F4)</p>			

- 1Way CST: AC026/035RN1DKG
- 4Way CST: AC052/071/100/120/140RN4DKG
- Ceiling: AC052/071RNCDKG
- Mini 4Way CST: AC026/035/052/071RNNDKG (cont.)
- ▶ Type B

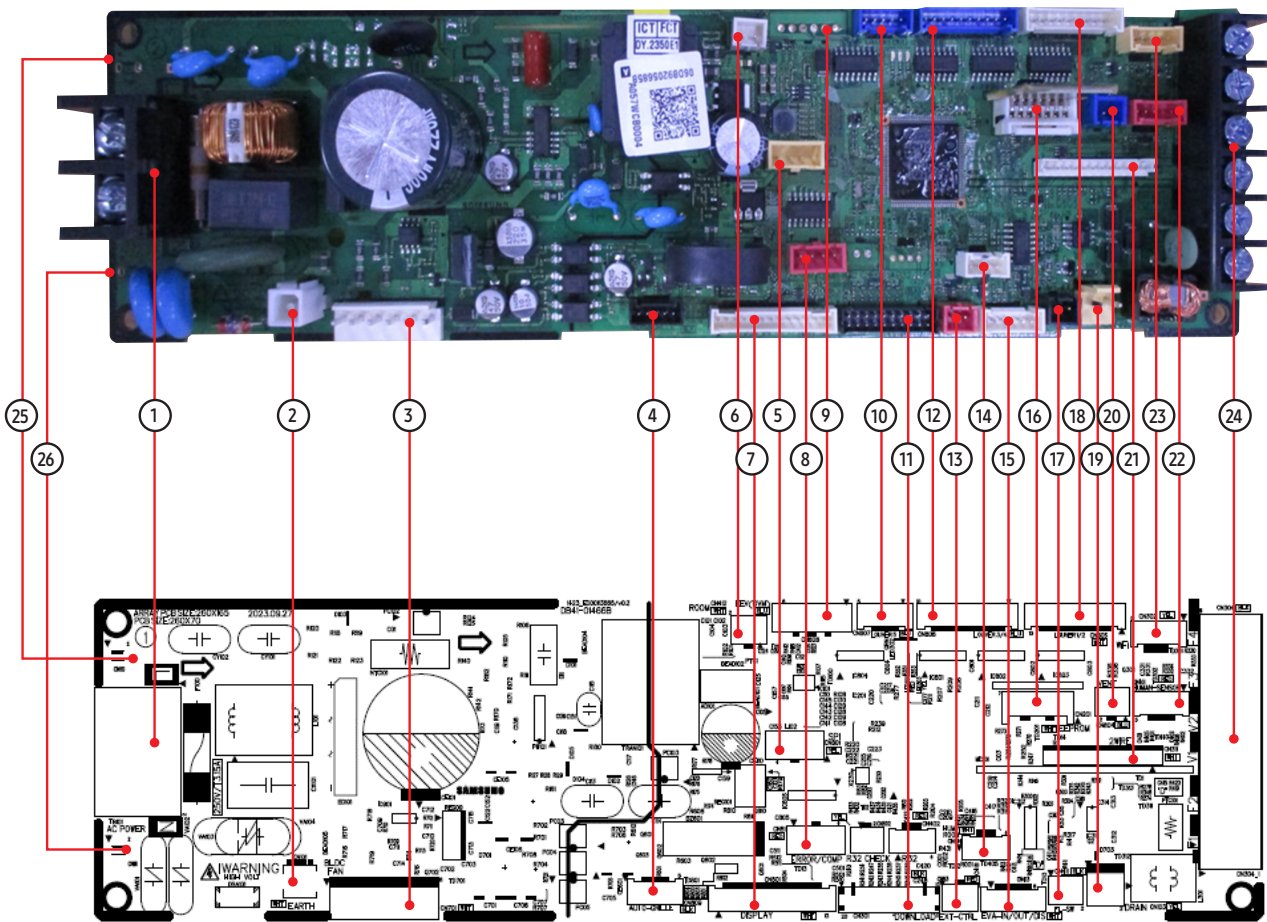

This Document can not be used without Samsung's authorization.

<p>① TB101-AC POWER #1: AC POWER (L) #2: AC POWER (N)</p>	<p>② CN101-EARTH #1: EARTH</p>	<p>③ CN701-BLDC MOTOR #1: DC310V #3: GND #4: DC15V #5: FAN RPM #6: RPM FEEDBACK</p>	<p>④ CN809-AUTO GRILLE #1: DC12V #4: REMOCON SIGNAL #5: GND</p>	<p>⑤ CN801-SPI #1: GND #2: GND #3: SPI SIGNAL (DC12V)</p>
<p>⑥ CN412-ROOM SENSOR #1: ROOM SENSOR #2: GND</p>	<p>⑦ CN501-DISPLAY #1: DC12V #2: LED_0 #3: LED_1 #4: LED_2 #5: LED_3 #6: LED_4 #7: LED_5 #8: REMOCON SIGNAL OUTPUT #9: AUTO SWITCH #10: REMOCON SIGNAL INPUT #11: GND #12: DC5V #13: GND</p>	<p>⑧ CN81-COMP/ERROR MONITOR #1: DC12V #2: ERROR OUT (GND) #3: DC12V #4: COMP/OPER. OUT (GND)</p>	<p>⑨ CN808-EEV (DVM) #1: WATER_VALVE1 #2: WATER_VALVE2 #3: NC #4: NC #5~#6: DC12V</p>	<p>⑩ CN807-LOUVER5 #1: DC12V #2~#5: LOUVER SIGNAL</p>
<p>⑪ CN301-DOWNLOAD</p>	<p>⑫ CN806-LOUVER3/4 #1: DC12V #2~#5: LOUVER SIGNAL #6: DC12V #7~#10: LOUVER SIGNAL</p>	<p>⑬ CN83-EXT CTRL #1: GND #2: EXTERNAL CONTROL SIGNAL</p>	<p>⑭ CN414-HUMIDITY SENSOR #1 DC5V #2: GND #3: THERMISTOR SENSOR #4: HUMIDITY SENSOR</p>	<p>⑮ CN413-THERMISTOR #1: EVA-IN SENSOR #2: GND #3: EVA-OUT SENSOR #4: GND #5: DISCHARGE SENSOR #6: GND</p>
<p>⑯ CN201-EEPROM #1: GND #3: DC5V #4: EEPROM_SELECT #5: EEPROM_SO #6: EEPROM_SI #7: EEPROM_CLK</p>	<p>⑰ CN411-FLOAT SWITCH #1: F/S SIGNAL #2: GND</p>	<p>⑱ CN805-LOUVER1/2 #1: DC12V #2~#5: LOUVER SIGNAL</p>	<p>⑲ CN103-DRAIN PUMP #1: DRAIN PUMP (DC12V) #2: GND</p>	<p>⑳ CN804-VENTILATOR #1: DC12V #2: VENT SIGNAL OUTPUT (GND)</p>
<p>㉑ CN311-2WIRED REMOCON</p>	<p>㉒ CN401-HUMAN SENSOR #1: DC12V #2: MAIN-HUMAN SENSOR COMM (TXD) #3: MAIN-HUMAN SENSOR COMM (TXD) #4: GND</p>	<p>㉓ CN302-WiFi #1: TXD #2: RXD #3: DC5V #4: GND #5: DC12V</p>	<p>㉔ TE04-COMMUNICATION #1: COM1 (F1) #2: COM1 (F2) #3: V1 (DC12V) #4: V2 (GND) #5: COM2 (F3) #6: COM2 (F4)</p>	<p>㉕ CN110-AC POWER #1: AC POWER (L)</p>
<p>㉖ CN111-AC POWER #1: AC POWER (N)</p>				

■ 360 CST: AC071/100/120/140RN4PKG

▶ Type A

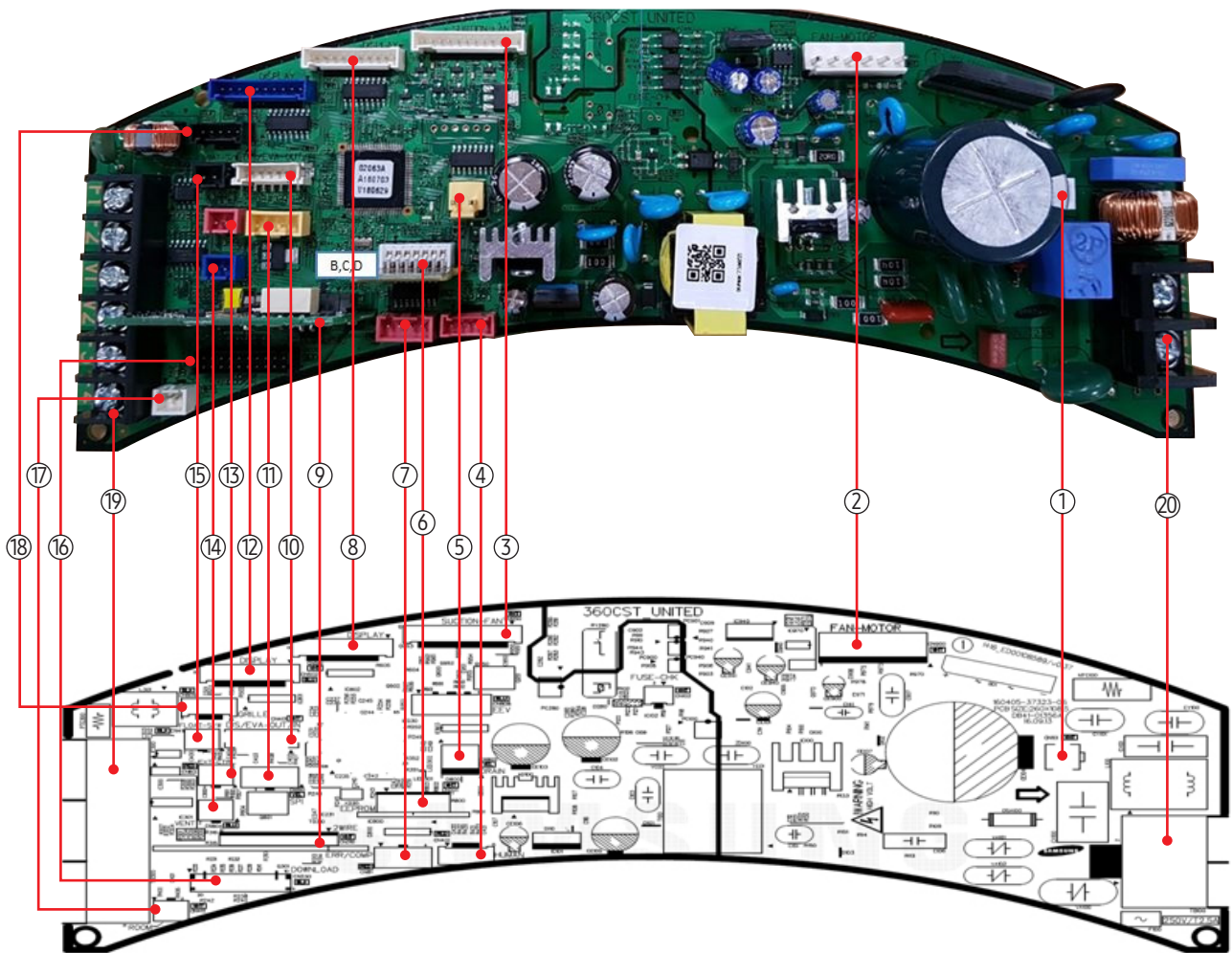

This Document can not be used without Samsung's authorization.

<p>① CN101-EARTH GND #1: EARTH</p>	<p>② CN900-BLDC MOTOR #1: DC 310V #3: GND #4: DC 15V #5: FAN RPM #6: RPM FEEDBACK</p>	<p>③ CN950-SUCTION FAN #1,#5 #9: DC12V #2 #6 #10: FAN FEEDBACK #3 #7 #11: GND #4 #8 #12: FAN CTRL</p>	<p>④ CN401-HUMAN SENSING SENSOR #1: DC12V #2: HUMAN SENSING SENSOR COMM (TXD) #3: HUMAN SENSING SENSOR COM (M (RXD)) #4: GND</p>	<p>⑤ CN802-DRAIN PUMP #1: D/P POWER (DC 12V) #2: GND</p>
<p>⑥ CN201-EEPROM #1: GND #3: DC 5V #4: EEPROM_SELECT #5: EEPROM_SO #6: EEPROM_SI #7: EEPROM_CLK</p>	<p>⑦ CN81-ERROR/COMP CHECK #1: DC12V #2: ERROR SIGNAL OUTPUT (GND) #3: DC12V #4: COMP/OPER. SIGNAL OUTPUT (GND) #13: GND</p>	<p>⑧ CN501-DISPLAY #1: BUZZER1 #2: BUZZER2 #3: LED1 #4: LED2 #5: LED3 #6: LED4 #7: LED5 #8: LED6 #9: LED7 #10: LED8</p>	<p>⑨ CN310-2WIRED REMOCON #1: DC12V #2: COM2_PCTRL_MICOM #3: COM2_VCHECK_A #4: COM2_VCHECK_B #5: COM2_MICOM_AD #6: VCC_PC_OUT (DC5V) #8: COM2_C (COM2_F3) #9: COM2_D (COM2_F4) #10: COM2_Tx #11: COM2_Rx #12: GND</p>	<p>⑩ CN413-THERNISTOR #1: EVA-IN SENSOR #2: GND #3: EVA-OUT SENSOR #4: GND #5: DISCHARGE SENSOR #6: GND</p>
<p>⑪ CN810-SPI #1: GND #2: GND #3: SPI POWER OUTPUT (DC12V)</p>	<p>⑫ CN502-DISPLAY #1: 12V #2: LED9 #3: LED10 #4: LED11 #5: LED12 #6: LED13 #7: REMOCON OUTPUT SIGNAL #8: REMOCON INPUTSIGNAL #9: GND #10: DV5V</p>	<p>⑬ CN83-EXL CTRL #1: F/S SIGNAL #2: GND</p>	<p>⑭ CN804-VENTILATOR #1: DC12V #2: VENTILATOR SIGNAL OUTPUT (GND)</p>	<p>⑮ CN411-FLOATS/W #1: F/S SIGNAL #2: GND</p>
<p>⑯ CN230-DOWNLOAD</p>	<p>⑰ CN412-ROOM SENSOR #1: ROOM SENSOR #2: GND</p>	<p>⑱ CN809-AUTO GRILL #1: DC12V #4: REMOCON SIGNAL #5: GND</p>	<p>⑲ TB300-COMMUNICATNION #1: COM1 (F1) #2: COM2 (F2) #3: V1 (DC12V) #4: V2 (GND) #5: COM2 (F3) #6: COM2 (F4)</p>	<p>⑳ TB100-AC POWER #1: AC POWER (L) #2: AC POWER (N)</p>

■ 360 CST: AC071/100/120/140RN4PKG (cont.)

▶ Type B

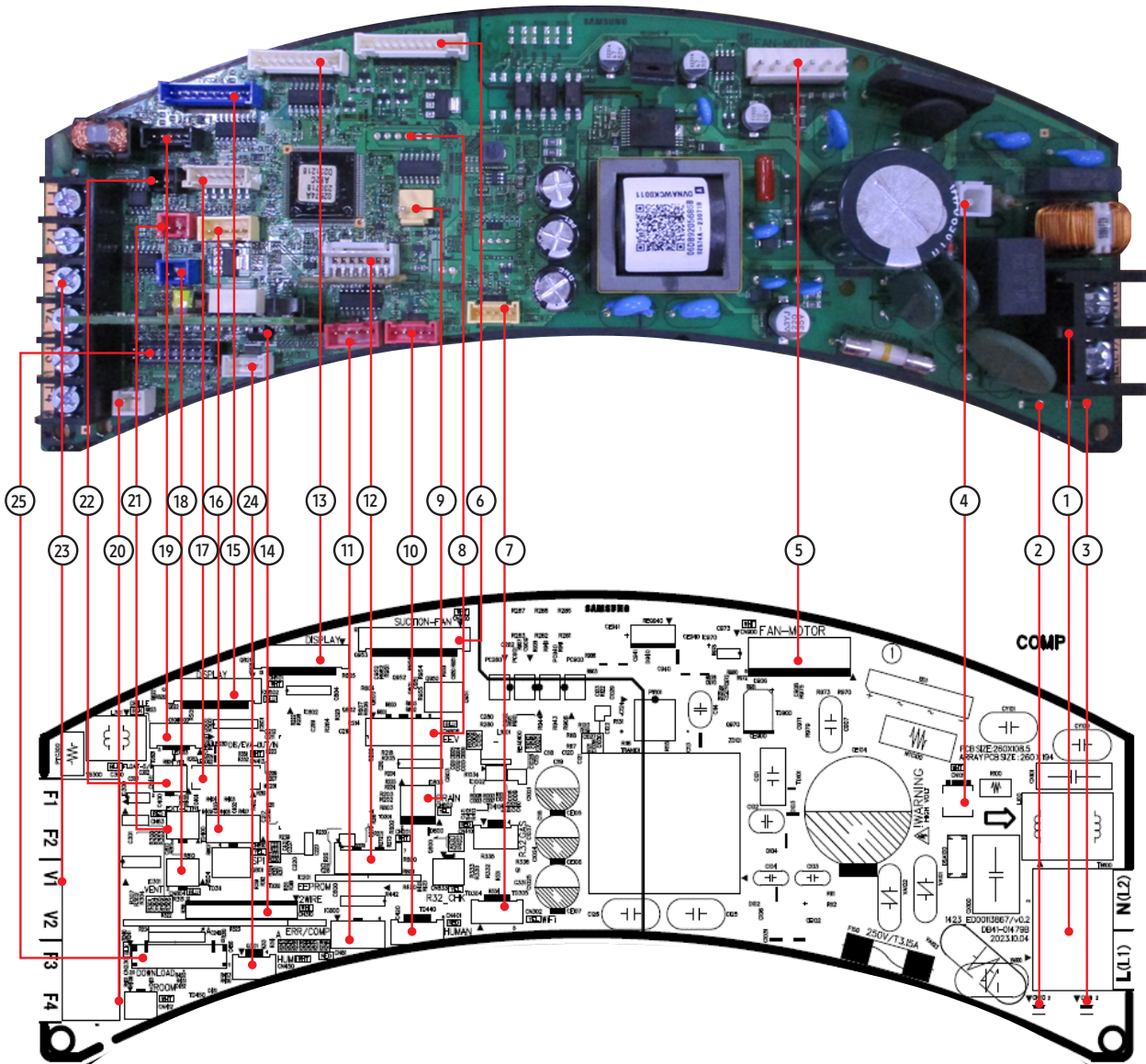

This Document can not be used without Samsung's authorization.

① TB100-AC POWER #1: AC POWER (L) #2: AC POWER (N)	② CN110-AC POWER #1: AC POWER (L)	③ CN111-AC POWER #1: AC POWER (N)	④ CN101-EARTH #1: GND	⑤ CN900-BLDC MOTOR #1: DC 310V #3: GND #4: DC 15V #5: FAN RPM #6: RPM FEEDBACK
⑥ CN950-SUCTION FAN #1,#5 #9: DC12V #2 #6 #10: FAN FEEDBACK #3 #7 #11: GND #4 #8 #12: FAN CTRL	⑦ CN302-WIFI #1: TXD #2: RXD #3: DCSV #4: GND #5: DC12V	⑧ CN808-EEV (DVM) #1: WATER_VALVE1 #2: WATER_VALVE2 #3: NC #4: NC #5~#6: DC12V	⑨ CN802-DRAIN PUMP #1: DRAIN PUMP (DC12V) #2: GND	⑩ CN401- HUMAN SENSOR #1: DC12V #2: MAIN-HUMAN SENSOR COMM (TXD) #3: MAIN-HUMAN SENSOR COMM (TXD) #4: GND
⑪ CN81-COMP/ERROR MONITOR #1: DC12V #2: ERROR OUT (GND) #3: DC12V #4: COMP/OPER. OUT (GND)	⑫ CN201-EEPROM #1: GND #3: DC 5V #4: EEPROM_SELECT #5: EEPROM_SO #6: EEPROM_SI #7: EEPROM_CLK	⑬ CN501-DISPLAY #1: BUZZER1 #2: BUZZER2 #3: LED1 #4: LED2 #5: LED3 #6: LED4 #7: LED5 #8: LED6 #9: LED7 #10: LED8	⑭ CN310-2WIRED REMOCON	⑮ CN502-DISPLAY #1: 12V #2: LED9 #3: LED10 #4: LED11 #5: LED12 #6: LED13 #7: REMOCON SIGNAL OUTPUT #8: REMOCON SIGNAL INPUT #9: GND #10: DV5V
⑯ CN810-SPI #1: GND #2: GND #3: SPI SIGNAL (DC12V)	⑰ CN413-THERMISTOR #1: EVA-IN SENSOR #2: GND #3: EVA-OUT SENSOR #4: GND #5: DISCHARGE SENSOR #6: GND	⑱ CN804-VENTILATOR #1: DC12V #2: VENTILATOR SIGNAL OUTPUT (GND)	⑲ CN809-AUTO GRILLE #1: DC12V #4: REMOCON SIGNAL #5: GND	⑳ CN412-ROOM SENSOR #1: ROOM SENSOR #2: GND
㉑ CN83-EXT CTRL #1: GND #2: EXTERNAL CONTROL SIGNAL	㉒ CN411-FLOAT SWITCH #1: F/S SIGNAL #2: GND	㉓ TB300-COMMUNICATNION #1: COM1 (F1) #2: COM2 (F2) #3: V1 (DC12V) #4: V2 (GND) #5: COM2 (F3) #6: COM2 (F4)	㉔ CN450-HUMIDITY SENSOR #1: DC 5V #2: GND #3: THERMISTOR SENSOR #4: HUMIDITY SENSOR	㉕ CN230-DOWNLOAD

■ Duct: AC026/035/052/071RNLDKG

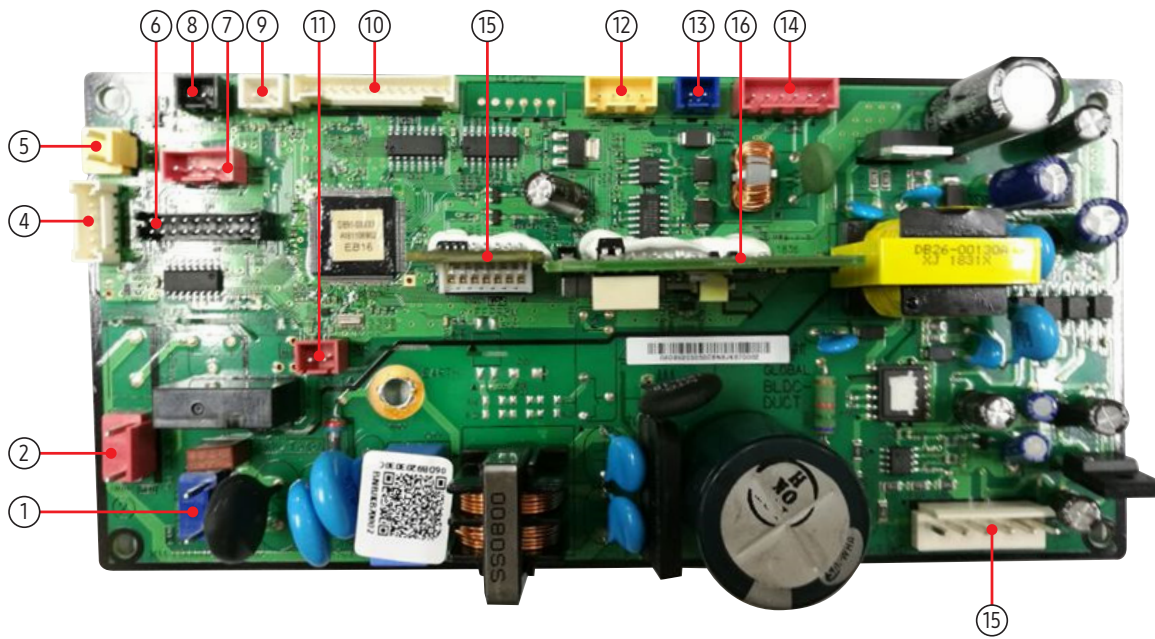

This Document can not be used without Samsung's authorization.

<p>① CN101: POWER #1: AC POWER (L) #3: AC POWER (N)</p>	<p>② CN702: HOT COIL #1: AC POWER (N) #3: HOT COIL POWER (L)</p>	<p>③ CN413: EVA IN/OUT/DIS #1: EVA IN SENSOR #2: GND #3: EVA OUT SENSOR #4: GND #5: DISCHARGE SENSOR #6: GND</p>	<p>④ CN103: DRAIN PUMP #1: DRAIN PUMP (DC12V) #2: GND</p>
<p>⑤ CN301: SW DOWNLOAD</p>	<p>⑥ CN81: ERROR/COMP CHECK #1: DC12V #2: ERROR OUT (GND) #3: DC12V #4: COMP/OPER. OUT (GND)</p>	<p>⑦ CN411: FLOAT SWITCH #1: FLOAT SWITCH SIGNAL #2: GND</p>	<p>⑧ CN411: FLOAT SWITCH #1: ROOM SENSOR #2: GND</p>
<p>⑨ CN501: DISPLAY #1: DC12V #2: LED_0 #3: LED_1 #4: LED_2 #5: LED_3 #6: LED_4 #7: BUZZER OUTPUT #8: REMOCON SIGNAL OUTPUT #9: AUTO SWITCH #10: REMOCON SIGNAL INPUT #11: GND #12: DC5V #13: BUZZER OUTPUT</p>	<p>⑩ CN83: EXT_CTRL #1: GND #2: EXT-CTRL SIGNAL</p>	<p>⑪ CN801: SPI #1: GND #2: GND #3: SPI SIGNAL (DC12V)</p>	<p>⑫ CN804: VENT #1: DC12V #2: VENTILATOR SIGNAL OUTPUT (GND)</p>
<p>⑬ CN302: COMM #1: COM1 (F1) #2: COM1 (F2) #3: V1 (DC12V) #4: V2 (GND) #5: COM2 (F3) #6: COM2 (F4)</p>	<p>⑭ CN703: BLDC FAN #1: DC310V #3: GND #4: DC15V #5: FAN RPM #6: RPM EFFDBACK</p>	<p>⑮ CN201: EEPROM #1: GND #3: DC 5V #4: EEPROM_SHEET #5: EEPROM_SO #6: EEPROM_SI #7: EEPROM_CLK</p>	<p>⑯ CN310: 2WIRED REMOCON #1: DC12V #2: COM2_PTCTRL_MICOM #3: COM2_VCHECK_A #4: COM2_VCHECK_B #5: COM2_MICOM_AD #6: Vcc_PS_OUT(DC5V) #7: COM2_ENABLE #8: COM2_C (COM2_F3) #9: COM2_D (COM2_F4) #10: COM2_Tx #11: COM2_Rx #12: GND</p>

■ Duct: AC035/052/071/100/120/140RNMDKG

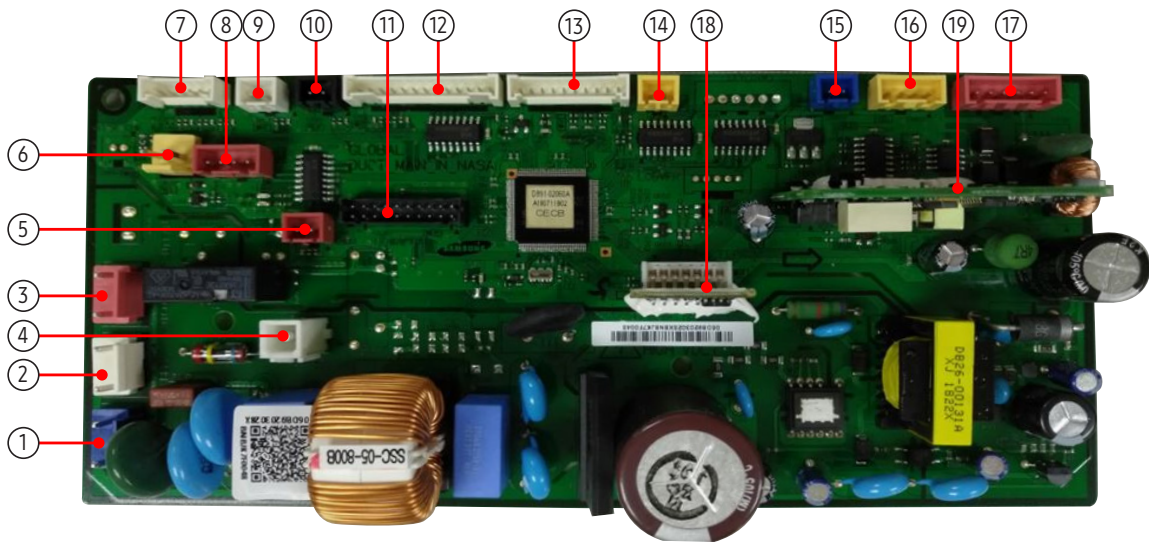

This Document can not be used without Samsung's authorization.

<p>① CN101: POWER #1: AC POWER (L) #3: AC POWER (N)</p>	<p>② CN906: BLDC PBA POWER #1: AC POWER (N) #3: AC POWER (L)</p>	<p>③ CN702: HOT COIL #1: N #2: NOT USED #3: L</p>	<p>④ CN1: EARTH #1: EARTH</p>
<p>⑤ CN83: EXT_CTRL #1: GND #2: EXT-CTRL SIGNAL</p>	<p>⑥ CN701: DRAIN PUMP #1: DRAIN PUMP (DC12V) #2: GND</p>	<p>⑦ CN413: EVA IN/OUT/DIS #1: EVA IN SENSOR #2: GND #3: EVA OUT SENSOR #4: GND #5: DISCHARGE SENSOR #6: GND</p>	<p>⑧ CN81: ERROR/COMP CHECK #1: DC12V #2: ERROR OUT (GND) #3: DC12V #4: COMP/OPER. OUT (GND)</p>
<p>⑨ CN412: ROOM #1: ROOM SENSOR #2: GND</p>	<p>⑩ CN411: FLOAT SWITCH #1: FLOAT SWITCH SIGNAL #2: GND</p>	<p>⑪ CN301: SW DOWNLOAD -</p>	<p>⑫ CN501: DISPLAY #1: DC12V #2: LED_0 #3: LED_1 #4: LED_2 #5: LED_3 #6: LED_4 #7: BUZZER OUTPUT #8: REMOCON SIGNAL OUTPUT #9: AUTO SWITCH #10: REMOCON SIGNAL INPUT #11: GND #12: DC5V #13: BUZZER OUTPUT</p>
<p>⑬ CN905: TO BLDC PBA SIGNAL #1: DC12V #2: GND #3: DC5V #4: BLDC POWER RELAY #5: OVER_TEMP #6: IPM_FAULT #7: REVERSE_OUT #8: FAN FEEDBACK #9: INRUSH_OUT #10: FAN_PWM</p>	<p>⑭ CN907: UART COMM. #1: MAIN_RXD_INV_TXD #2: MAIN_TXD_INV_RXD</p>	<p>⑮ CN804: VENT #1: DC12V #2: VENTILATOR SIGNAL OUTPUT (GND)</p>	<p>⑯ CN801: SPI #1: GND #2: GND #3: SPI SIGNAL (DC12V)</p>
<p>⑰ CN302: COMM. #1: COM1 (F1) #2: COM1 (F2) #3: V1 (DC12V) #4: V2 (GND) #5: COM2 (F3) #6: COM2 (F4)</p>	<p>⑱ CN302: EEPROM #1: GND #3: DC 5V #4: EEPROM_SHEET #5: EEPROM_SO #6: EEPROM_SI #7: EEPROM_CLK</p>	<p>⑲ CN302: 2WIRED REMOCON #1: DC12V #2: COM2_PTCRL_MICOM #3: COM2_VCHECK_A #4: COM2_VCHECK_B #5: COM2_MICOM_AD #6: Vcc_PS_OUT (DC5V) #7: COM2_ENABLE #8: COM2_C (COM2_F3) #9: COM2_D (COM2_F4) #10: COM2_Tx #11: COM2_Rx #12: GND</p>	

■ C-RAC: AC026/035/052/071RNADKG, AC100RNTDKG

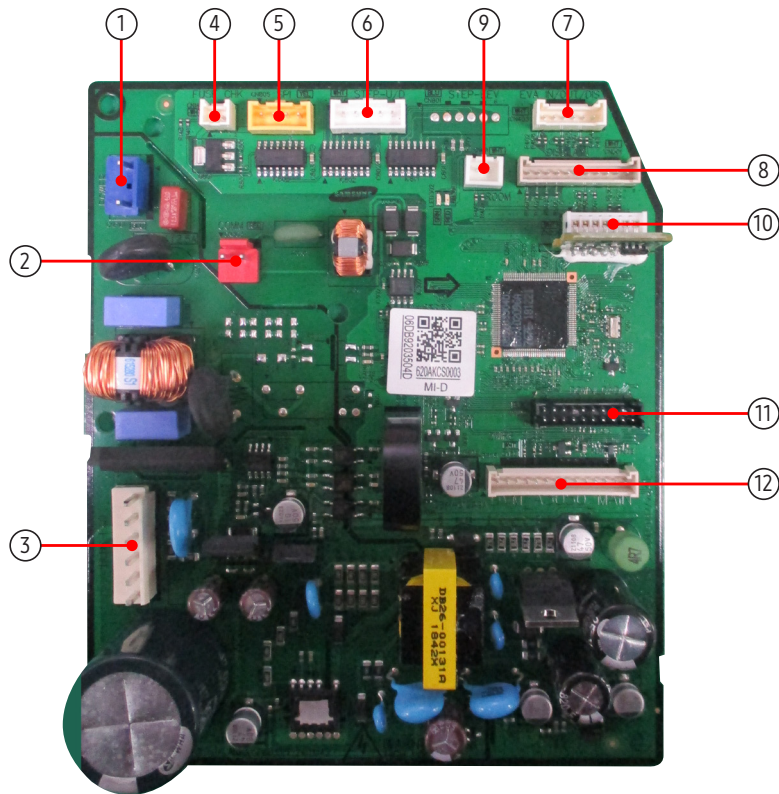

This Document can not be used without Samsung's authorization.

<p>① CNP101-POWER #1: AC POWER (L) #3: AC POWER (N)</p>	<p>② CN303-COM1 #1: COM2 (F3) #2: COM2 (F4)</p>	<p>③ CN701-BLDC FAN #1: DC 310V #3: GND #4 : DC 15V #5 : PWM SIGNAL #6 : FEEDBACK SIGNAL</p>	<p>④ CN140-FUSE CHECK #1: THERMAL FUSE SIGNAL #2: GND</p>
<p>⑤ CN805-SPI #1: GND #2: GND #3: SPI CONTROL SIGNAL</p>	<p>⑥ CN802-STEP UP/DOWN #1: DC 12V #2-5: LOUVER SIGNAL</p>	<p>⑦ CN403-EVA IN/OUT/DIS #1: EVA IN SENSOR #2: GND #3: EVA OUT SENSOR #4: GND #5: DISCHARGE SENSOR #6: GND</p>	<p>⑧ CN501-DISPLAY #1: LED_0 #2: LED_1 #3: LED_2 #4: AUTO_SW #5: GND #6: DC5V #7: REMOCON SIGNAL INPUT #8: LED_SPI</p>
<p>⑨ CN401-ROOM #1: ROOM SENSOR #2: GND</p>	<p>⑩ CN201-EEPROM #1: GND #3: DC 5V #4: EEPROM_SELECT #5: EEPROM_SO #6: EEPROM_SI #7: EEPROM_CLK</p>	<p>⑪ CN302-DOWNLOAD</p>	<p>⑫ CN301-to 2WIRE SUB #1: COM2_Tx #2: COM2_Rx #3: COM2_INVERSE #4: COM2_ENABLE #5: EXT_CTRL #6: COMP_OPER_CHECK #7: ERROR_CHECK #8: COM2_PS_OUT(DC5V) #9: GND #10: DC12V #11: COM2_PTCTRL_MICOM #12: COM2_VCHECK_A #13: COM2_VCHECK_B #14: COM2_VCHECK_AD</p>

■ Ceiling: AC100/120/140RNCDKG

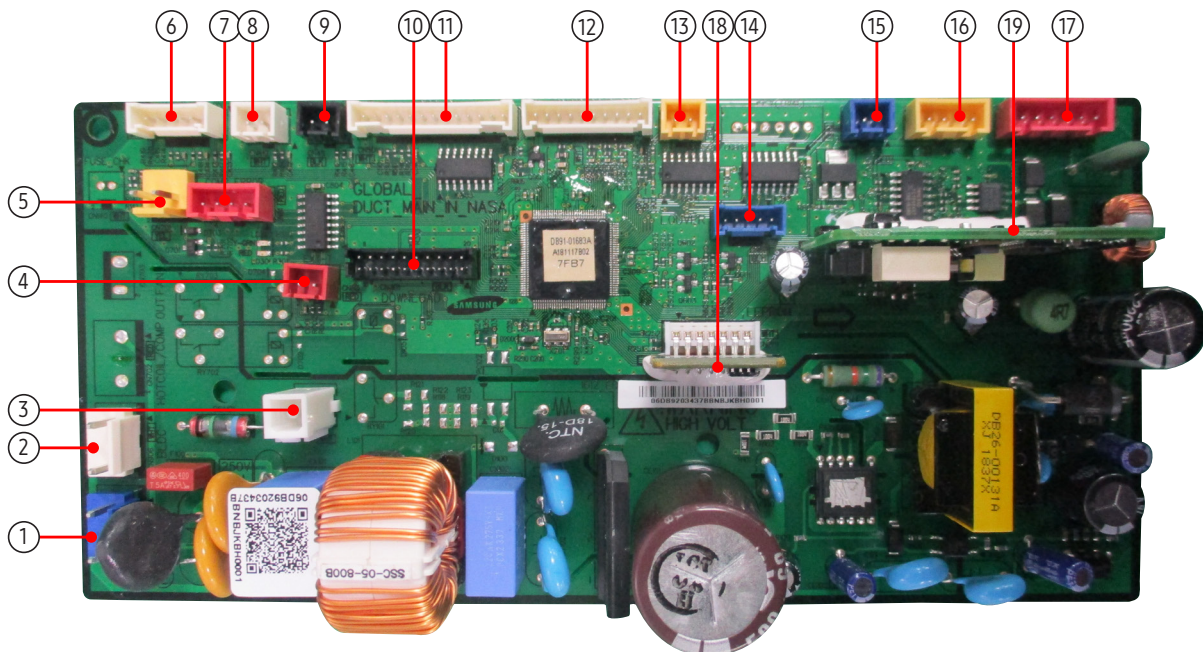

This Document can not be used without Samsung's authorization.

① CN101: POWER #1: AC POWER (L) #3: AC POWER (N)	② CN906: BLDC PBA POWER #1: AC POWER (N) #3: AC POWER (L)	③ CN1: EARTH #1: EARTH	④ CN83: EXT_CTRL #1: GND #2: EXT-CTRL SIGNAL
⑤ CN701: DRAIN PUMP #1: DRAIN PUMP (DC12V) #2: GND	⑥ CN413: EVA IN/OUT/DIS #1: EVA IN SENSOR #2: GND #3: EVA OUT SENSOR #4: GND #5: DISCHARGE SENSOR #6: GND	⑦ CN81: ERROR/COMP CHECK #1: DC12V #2: ERROR OUT (GND) #3: DC12V #4: COMP/OPER. OUT (GND)	⑧ CN412: ROOM #1: ROOM SENSOR #2: GND
⑨ CN411: FLOAT SWITCH #1: FLOAT SWITCH SIGNAL #2: GND	⑩ CN301: SW DOWNLOAD -	⑪ CN501: DISPLAY #1: DC12V #2: LED_0 #3: LED_1 #4: LED_2 #5: LED_3 #6: LED_4 #7: BUZZER OUTPUT #8: REMOCON SIGNAL OUTPUT #9: AUTO SWITCH #10: REMOCON SIGNAL INPUT #11: GND #12: DC5V #13: BUZZER OUTPUT	⑫ CN905: TO BLDC PBA SIGNAL #1: DC12V #2: GND #3: DC5V #4: BLDC POWER RELAY #5: OVER_TEMP #6: IPM_FAULT #7: REVERSE_OUT #8: FAN FEEDBACK #9: INRUSH_OUT #10: FAN_PWM
⑬ CN907: UART COMM. #1: MAIN_RXD_INV_TXD #2: MAIN_TXD_INV_RXD	⑭ CN804: VENT #1: DC12V #2: VENTILATOR SIGNAL OUTPUT (GND)	⑮ CN801: SPI #1: GND #2: GND #3: SPI SIGNAL (DC12V)	⑯ CN302: COMM. #1: COM1 (F1) #2: COM1 (F2) #3: V1 (DC12V) #4: V2 (GND) #5: COM2 (F3) #6: COM2 (F4)
⑰ CN302: EEPROM #1: GND #3: DC 5V #4: EEPROM_SHEET #5: EEPROM_SO #6: EEPROM_SI #7: EEPROM_CLK	⑱ CN302: 2WIRED REMOCON #1: DC 12V #2: COM2_PTCRL_MICOM #3: COM2_VCHECK_A #4: COM2_VCHECK_B #5: COM2_MICOM_AD #6: Vcc_PS_OUT (DC5V) #7: COM2_ENABLE #8: COM2_C (COM2_F3) #9: COM2_D (COM2_F4) #10: COM2_Tx #11: COM2_Rx #12: GND	⑲ CN601: LOUVER #1: DC12V #2~#5: LOUVER SIGNAL	

■ Console: AC026/035/052RNJDKG
▶ Type A

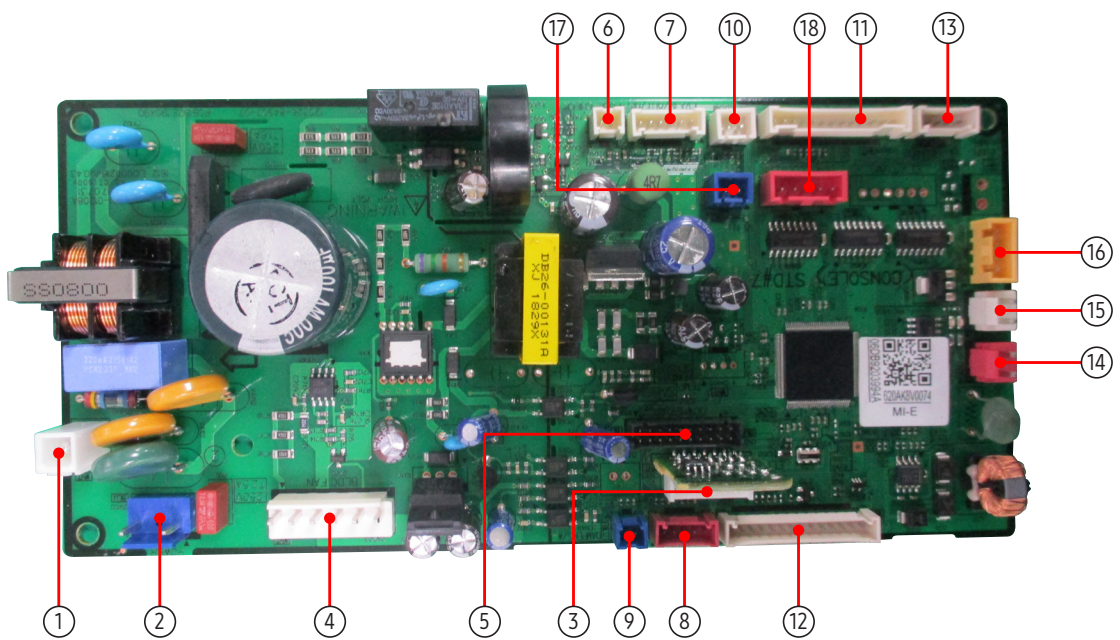

This Document can not be used without Samsung's authorization.

① CN101: EARTH #1: EARTH	② CN100: AC POWER #1: AC POWER (L) #3: AC POWER (N)	③ CN201: EEPROM #1: GND #3: DC 5V #4: EEPROM_SELECT #5: EEPROM_SO #6: EEPROM_SI #7: EEPROM_CLK	④ CN703: BLDC MOTOR #1: DC 310V #3: GND #4: DC 15V #5: FAN RPM #6: RPM FEEDBACK
⑤ CN83: DOWNLOAD	⑥ CN140: FUSE CHECK #1: THERMAL FUSE SIGNAL #2: GND	⑦ CN413: THERMISTOR #1: EVA IN SENSOR #2: GND #3: EVA OUT SENSOR #4: GND #5: DISCHARGE SENSOR #6: GND	⑧ CN401: HUMAN SENSING #1: DC12V #2: HUMAN SENSING SENSOR COMM (TXD) #3: HUMAN SENSING SENSOR COMM (M(RXD)) #4: GND
⑨ CN411: DAMPER S/W #1: DAMPER SWITCH SIGNAL #2: GND	⑩ CN412: ROOM SENSOR #1: ROOM SENSOR #2: GND	⑪ CN301: DISPLAY #1: DC12V #2: LED_0 #3: LED_1 #4: LED_2 #5: LED_3 #6: LED_4 #7: DC5V #8: REMOCON SIGNAL OUTPUT #9: AUTO SWITCH #10: REMOCON SIGNAL INPUT #11: GND #12: DC5V	⑫ CN501: 2WIRED REMOCON #1: COM2_Tx #2: COM2_Rx #3: COM2_INVERSE #4: COM2_ENABLE #5: EXT_CTRL #6: COMP_OPER_CHECK #7: ERROR_CHECK #8: COM2_PS_OUT(DC5V) #9: GND #10: DC12V #11: COM2_PTCRL_MICOM #12: COM2_VCHECK_A #13: COM2_VCHECK_B #14: COM2_VCHECK_AD
⑬ CN2: LOUVER #1: DC12V #2~#5: LOUVER SIGNAL	⑭ CN31: COMMUNICATION #1: COM2 (F3) #2: COM2 (F4)	⑮ CN32: DC12V #1: DC12V #2: GND	⑯ CN801: SPI #1: GND #2: GND #3: SPI SIGNAL (DC 12V)
⑰ CN804: VENTILATOR #1: DC 12V #2: VENT SIGNAL OUTPUT (GND)	⑱ CN806: DOWN LOUVER #1: DC12V #2~#5: LOUVER SIGNAL		

■ Console: AC026/035/052RNJDKG (cont.)

▶ Type B

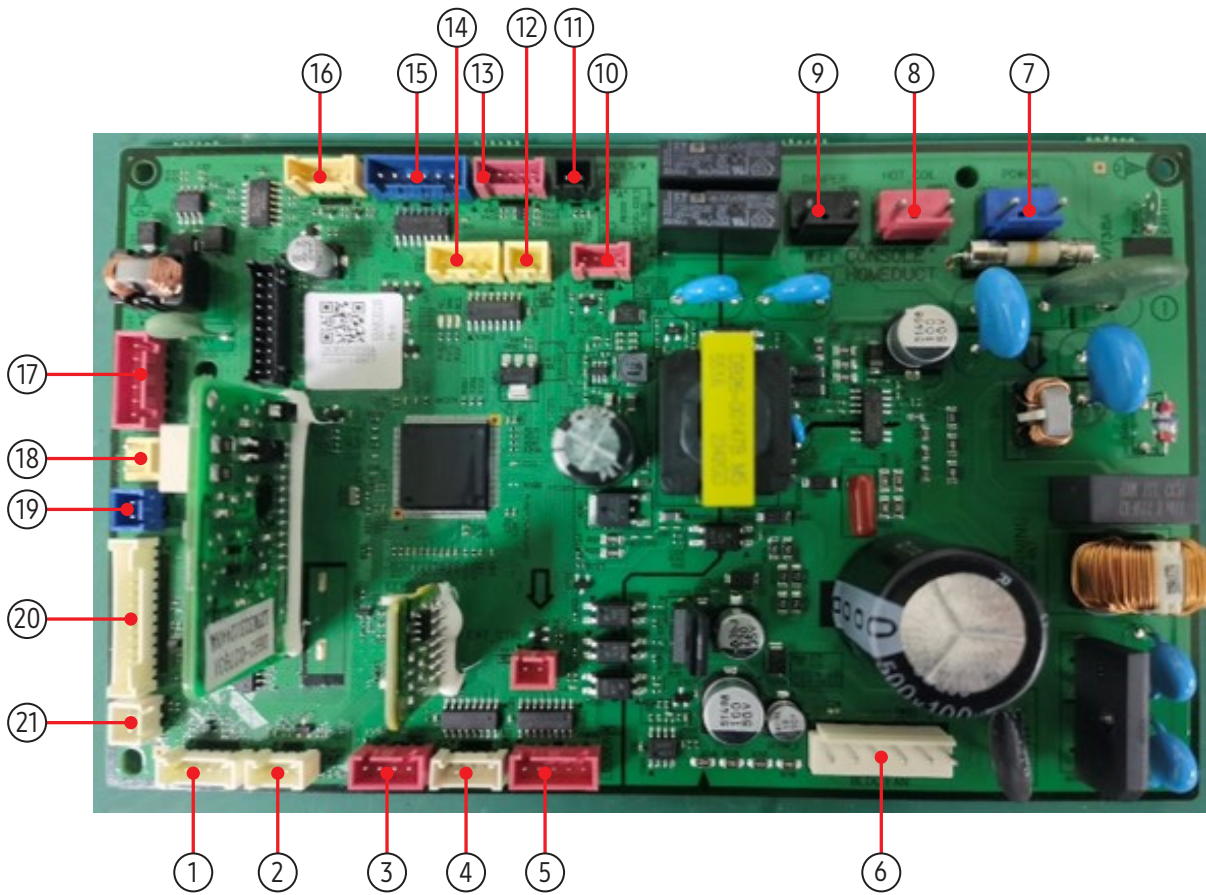

This Document can not be used without Samsung's authorization.

① CN413-THERMISTOR #1: EVA-IN SENSOR #2: GND #3: EEV_OUT SENSOR #4: GND #5: DISCHARGE SENSOR #6: GND	② CN405-HUMIDITY SENSOR #1: DC 5V #2: GND #3: THERMISTOR SENSOR #4: HUMIDITY SENSOR	③ CN81-COMP/ERROR MONITOR #1: DC12V #2: ERROR OUT (GND) #3: DC12V #4: COMP/OPER OUT (GND)	④ CN2-STEP MOTOR1 #1: 12V #2: SIGNAL1 #3: SIGNAL2 #4: SIGNAL3 #5: SIGNAL4
⑤ CN806-STEP MOTOR2 #1: 12V #2: SIGNAL1 #3: SIGNAL2 #4: SIGNAL3 #5: SIGNAL4	⑥ CN703-BLDC MOTOR #1: 310VDC #2: NULL #3: P_GND #4: 15VDC #5: MOTOR SIGNAL #6: FEEDBACK SIGNALL	⑦ CN100-AC POWER #1: AC POWER (L1) #2: AC POWER (L2)	⑧ CN102-HOT COIL1 #1: AC POWER (L2) #2: AC POWER (L1)
⑨ CN103-DAMPER #1: AC POWER (L2) #2: AC POWER (L1)	⑩ CN415-R32 SENSOR #1: GND #2: SIGNAL1 #3: SIGNAL2 #4: 5VDC	⑪ CN414-DAMPER SWITCH #1: DAMPER SIGNAL #2: GND	⑫ CN82-R32 CHECK #1: 12VDC #2: R32 CHECK SIGNAL
⑬ CN401-HUMAN SENSING #1: 12VDC #2: TXD #3: RXD #4: NULL #5: GND	⑭ CN805-SPI/UVC LED #1: GND #4: NULL #3: SIGNAL #4: NULL	⑮ CN808-EEV (DVM) #1: EEV_B_BAR_OUT #2: EEV_A_BAR_OUT #3: EEV_B_OUT #4: EEV_A_OUT #5: 12V #6: 12V	⑯ CN302-WIFI #1: TXD #2: RXD #3: DC5V #4: GND #5: DC12V
⑰ CN301-COMMUNICATION #1: COM1 (F1) #2: COM1 (F2) #3: V1 (DC12V) #4: V2 (GND) #5: COM2 (F3) #6: COM2 (F4)	⑱ CN800-DRAIN PUMP #1: DRAIN PUMP (DC12V) #2: GND	⑲ CN804-VENTILATOR #1: DC12V #2: VENT SIGNAL OUTPUT (GND)	⑳ CN511-DISPLAY #1: DC12V #2~#6: LED OUT (0,1,2,3,4) #8: REMOCON_SIGN_OUT #9: AUTO_SW #10: REMOCON_INT #11: GND #12: DV 5V #13: BUZZER_2
㉑ CN412-ROOM SENSOR #1: ROOM SENSOR #2: GND	㉒ CN412-ROOM SENSOR #1: EARTH		

5-1-2 Display PCB

■ 360 CST: AC071/100/120/140RN4PKG

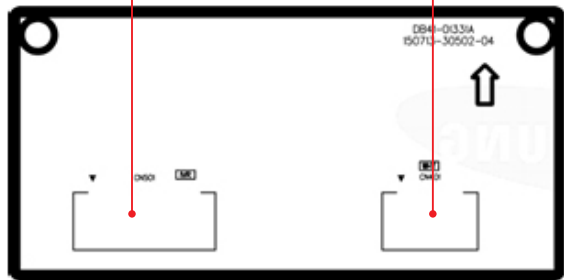
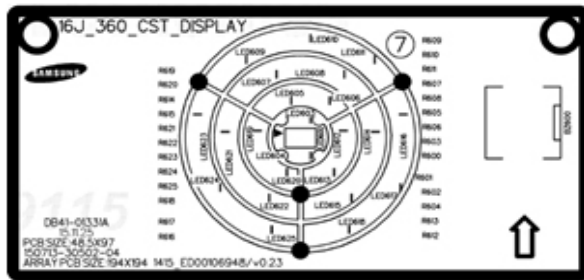
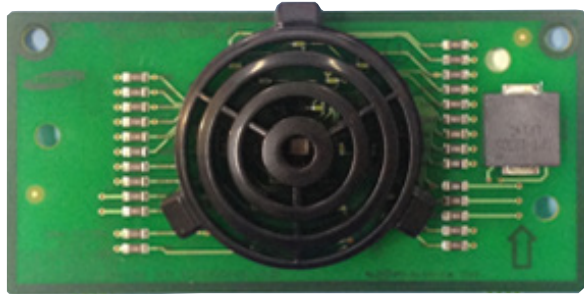

②

①

① **CN401 – DISPLAY1**

- #1: 12V
- #2: VISUALIZATION LED_SECTION2, LAYER2
- #3: VISUALIZATION LED_SECTION2, LAYER3
- #4: VISUALIZATION LED_SECTION3, LAYER1
- #5: VISUALIZATION LED_SECTION3, LAYER2
- #6: VISUALIZATION LED_SECTION3, LAYER3

② **CN501 – DISPLAY 2**

- #1: BUZZER1
- #2: BUZZER2
- #3: CENTER 3 COLOR LED - BLUE
- #4: CENTER 3 COLOR LED - GREEN
- #5: CENTER 3 COLOR LED - RED
- #6: CENTER LED – ICE BLUE
- #7: VISUALIZATION LED_SECTION1, LAYER1
- #8: VISUALIZATION LED_SECTION1, LAYER2
- #9: VISUALIZATION LED_SECTION1, LAYER3
- #10: VISUALIZATION LED_SECTION2, LAYER1

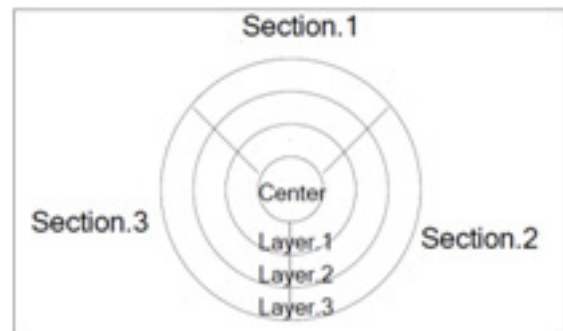

This Document can not be used without Samsung's authorization.

■ C-RAC: AC***RNADKG

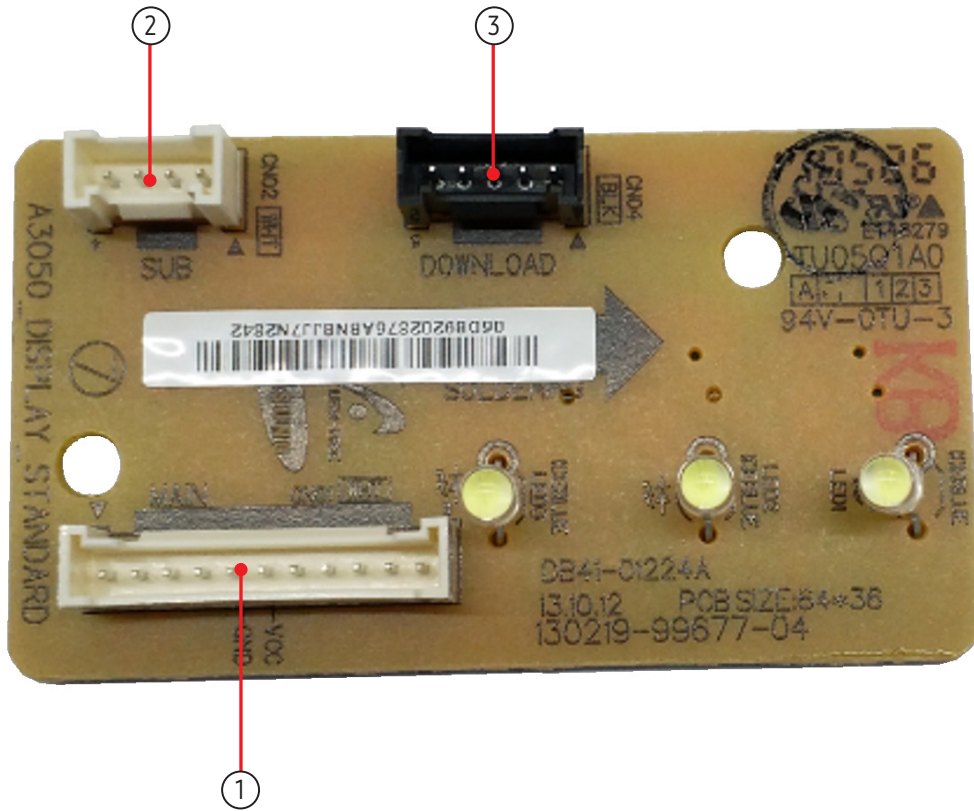

① CN01 - DISPLAY	② CN02 - SUB	③ CN04 - DOWNLOAD
#1: LED1	#1: GND	#1: VCC
#2: LED2	#2: DISPLAY	#2: TEST_RX
#3: LED3	#3: VCC	#3: TEST_TX
#4: GND	#4: GND	#4: MODE0
#5: GND		#5: GND
#6: VCC		
#7: SUB		
#8: -		
#9: TEST_RX		
#10: TEST_TX		
#11: MODE0		

■ C-RAC: AC100RNTDKG

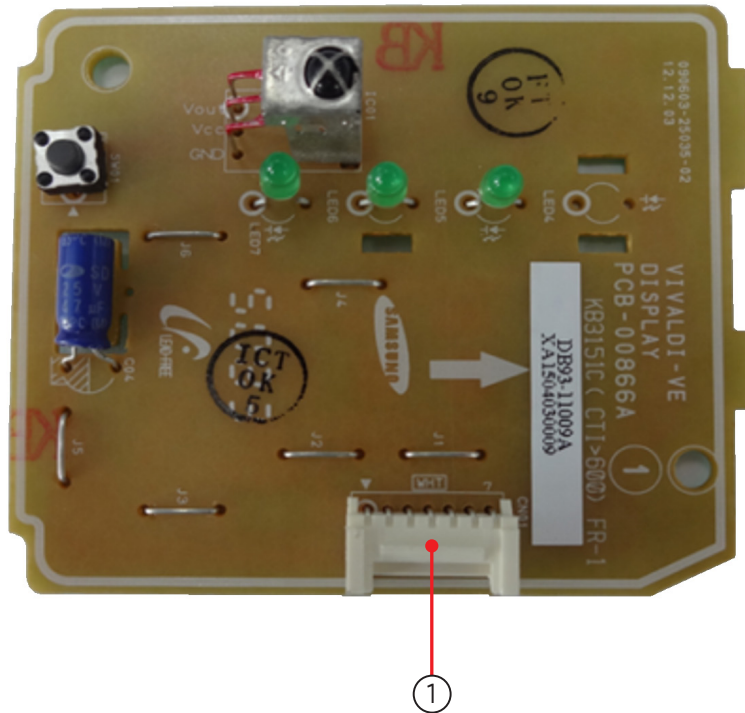

① CN101-DISPLAY

- #1: DC12V
- #2: LED_0
- #3: LED_1
- #4: LED_2
- #5: LED_3
- #6: LED_4
- #7: LED_5
- #8: REMOCON SIGNAL
- #9: PANEL SELECTION
- #10: REMOCON INT
- #11: GND
- #12: DC5V
- #13: -

■ Ceiling : AC052/071RNCDKG

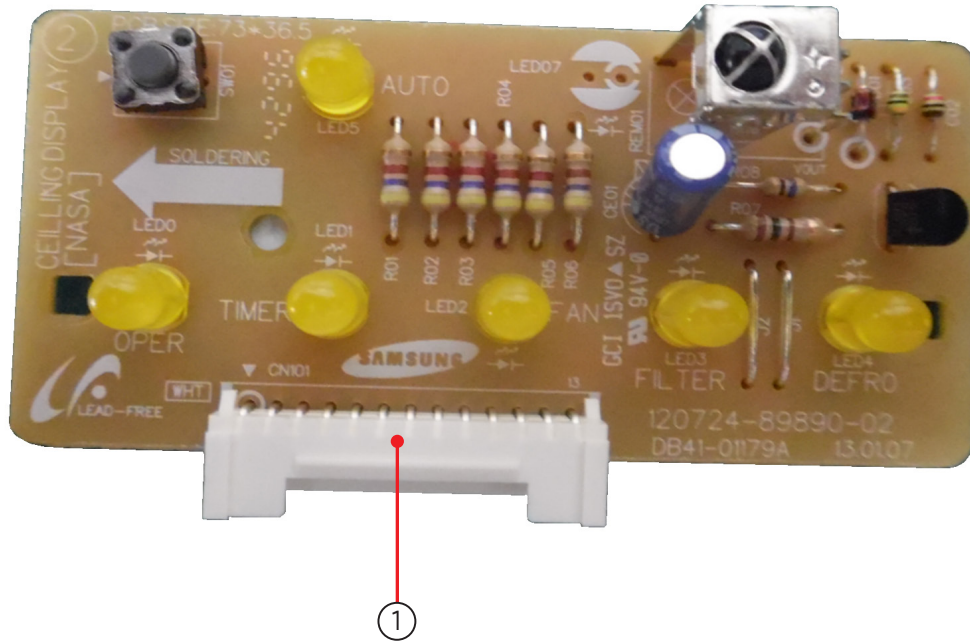

① CN101-DISPLAY
#1: DC12V
#2: LED_0
#3: LED_1
#4: LED_2
#5: LED_3
#6: LED_4
#7: LED_5
#8: REMOCON SIGNAL
#9: PANEL SELECTION
#10: REMOCON INT
#11: GND
#12: DC5V
#13: -

■ Ceiling: AC100/120/140RNCDKG

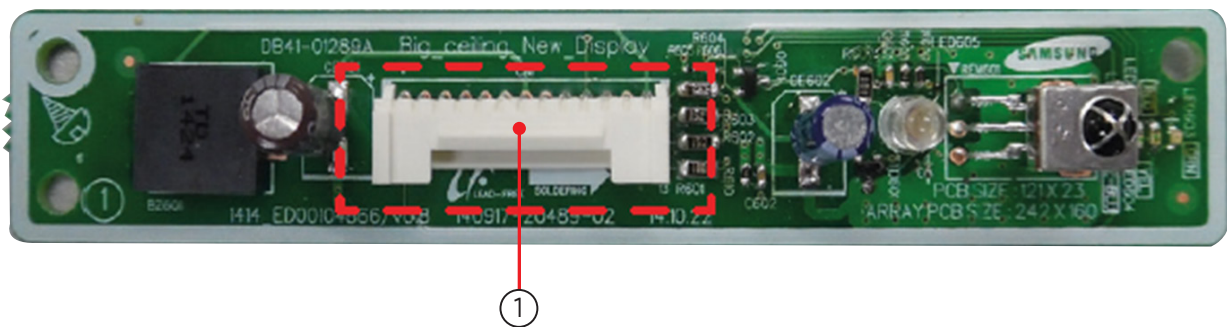

①	CN01: DISPLAY
#1:	DC12V
#1-6:	LED0-4
#7:	Buzzer
#8:	REMOCON SIGNAL
#9:	AUTO S/W
#10:	REMOCON INT
#11:	GND
#12:	VCC
#13:	BUZZER 2

■ Console: AC***RNJDKG

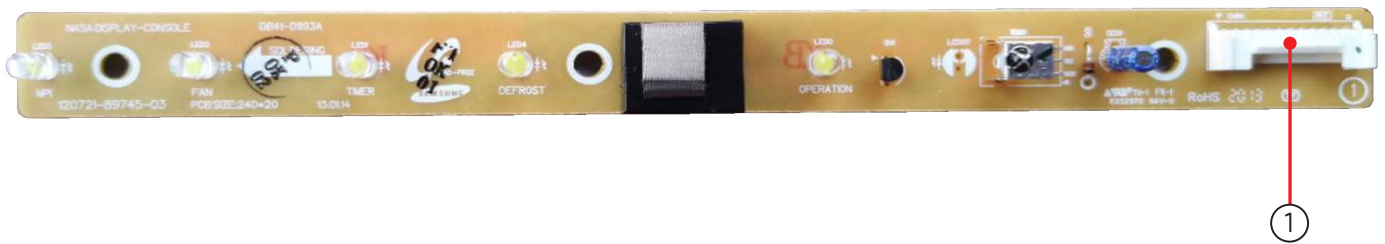

- | | |
|------|----------------------|
| ① | CN101-DISPLAY |
| #1: | DC12V |
| #2: | LED_0 |
| #3: | LED_1 |
| #4: | LED_2 |
| #5: | LED_3 |
| #6: | LED_4 |
| #7: | LED_5 |
| #8: | REMOCON SIGNAL |
| #9: | PANEL SELECTION |
| #10: | REMOCON INT |
| #11: | GND |
| #12: | DC5V |
| #13: | - |

5-1-3 Sub PCB

■ C-RAC: AC026/035/052/071RNADKG, AC100RNTDKG

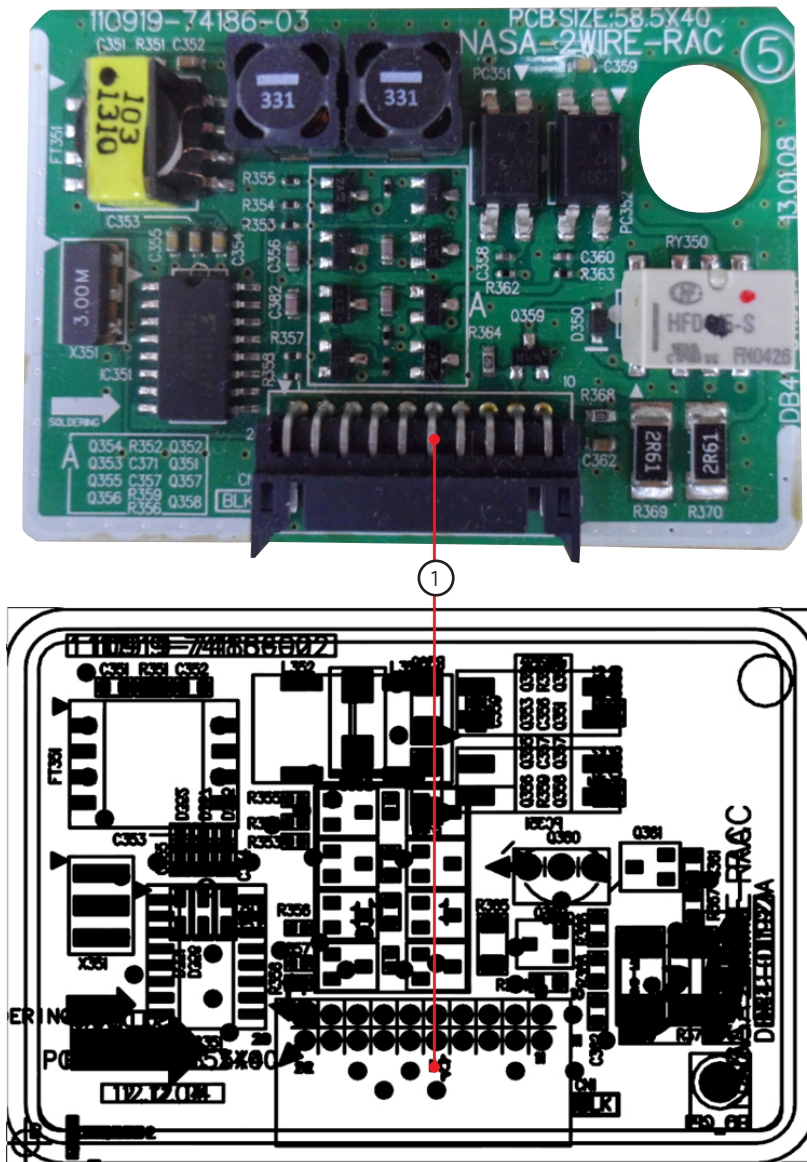

① CN1-2WIRES COMM.

- #1,#2,#19,#20: COMM. SIGNAL
- #3,#18: EXTERNAL CONTROL
- #4,#17: COMP CHECK
- #5,#16: ERROR CHECK
- #6: VCC (DC5V)
- #7,#14: GND
- #8,#13,#15: DC12V
- #9~#12: COMM. SIGNAL

This Document can not be used without Samsung's authorization.

- 1Way CST: AC***RN1DKG
- 4Way CST: AC***RN4DKG
- Mini4way CST: AC***RNNDKG
- Ceiling: AC052/071RNCDKG

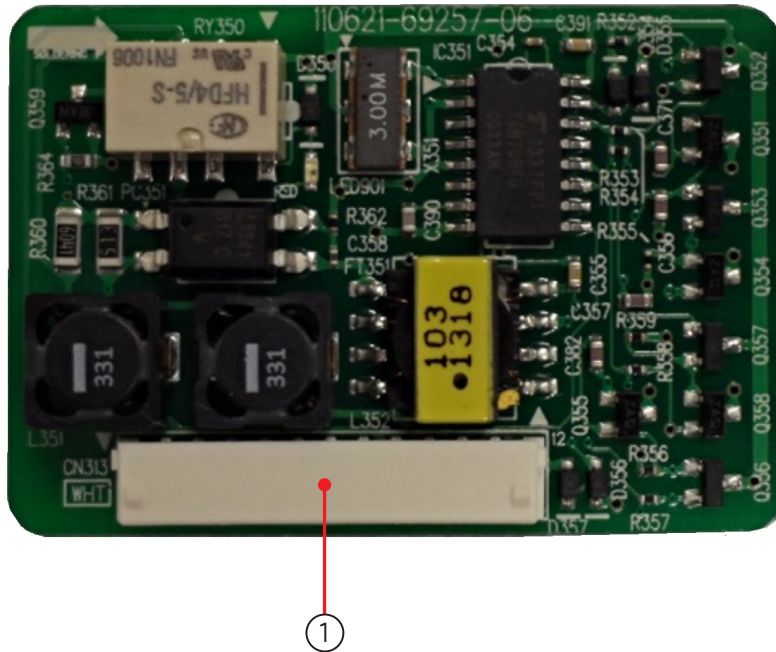

①	CN313-2 WIRE
#1:	DC12V
#2:	COM2_PCTRL_MICOM
#3:	COM2_VCHECK_A
#4:	COM2_VCHECK_B
#5:	COM2_MICOM_AD
#6:	Vcc_PS_OUT
#7:	COM2_ENABLE
#8:	COM2_C
#9:	COM2_D
#10:	COM2_Tx
#11:	COM2_Rx
#12:	GND

5-1-4 BLDC PBA

■ Duct: AC***RNMDKG

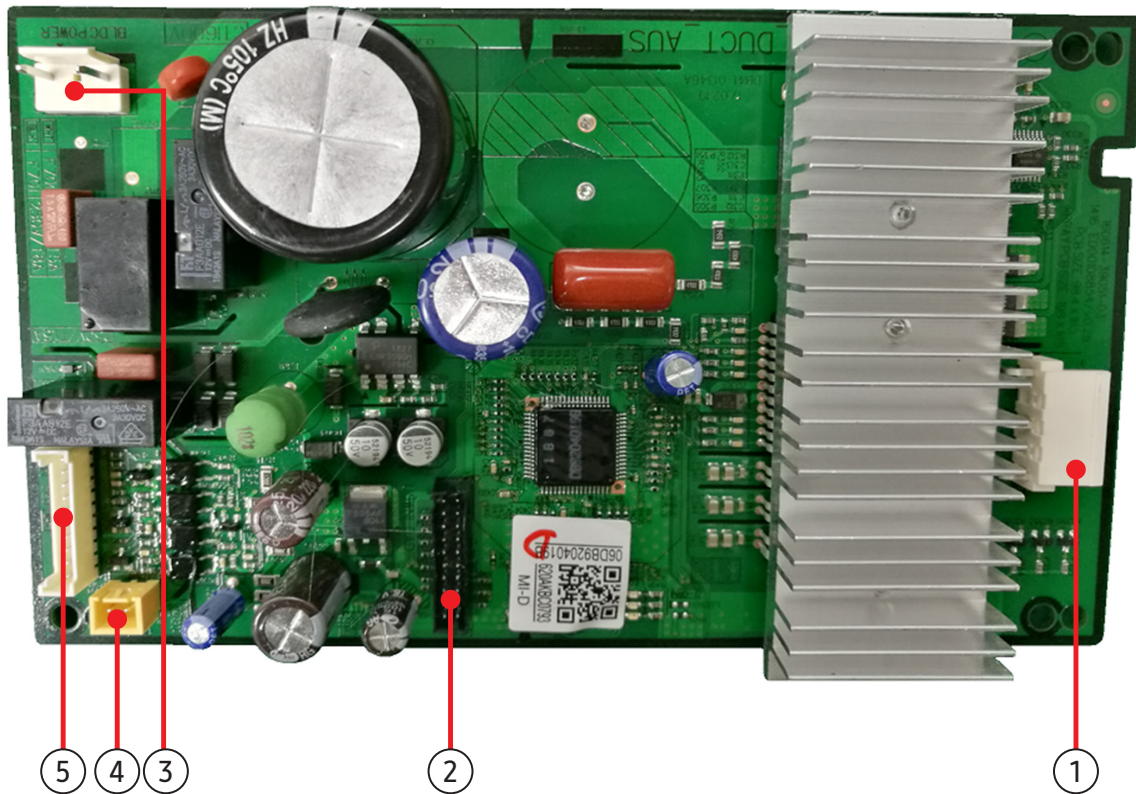

<p>① CN301: FAN MOTOR #1: MOTOR-U PHASE #2: NOT USED #3: MOTOR-V PHASE #4: NOT USED #5: MOTOR-W PHASE</p>	<p>② CN461: SW DOWNLOAD -</p>	<p>③ CN701: POWER #1: AC POWER (N) #3: AC POWER (L)</p>	<p>④ CN502: UART COMM. #1: MAIN_RXD_INV_TXD #2: MAIN_TXD_INV_RXD</p>
<p>⑤ CN501: TO MAIN SIGNAL #1: DC12V #2: GND #3: DC5V #4: BLDC POWER RELAY #7: GND #8: FAN FEEDBACK #10: FAN RPM</p>			

■ Ceiling: AC100/120/140RNCDKG

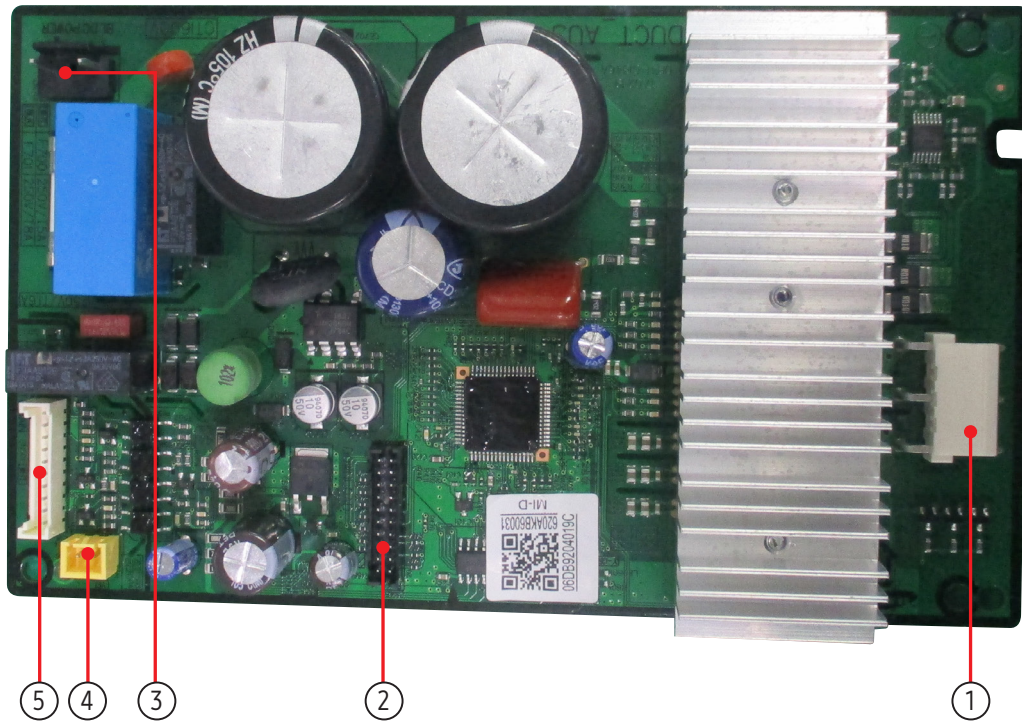

<p>① CN301: FAN MOTOR #1: MOTOR-U PHASE #2: NOT USED #3: MOTOR-V PHASE #4: NOT USED #5: MOTOR-W PHASE</p>	<p>② CN461: SW DOWNLOAD -</p>	<p>③ CN701: POWER #1: AC POWER (N) #3: AC POWER (L)</p>	<p>④ CN502: UART COMM. #1: MAIN_RXD_INV_TXD #2: MAIN_TXD_INV_RXD</p>
<p>⑤ CN501: TO MAIN SIGNAL #1: DC12V #2: GND #3: DC5V #4: BLDC POWER RELAY #7: GND #8: FAN FEEDBACK #10: FAN RPM</p>			

This Document can not be used without Samsung's authorization.

5-1-5 Receiver PCB

■ C-RAC: AC***RNADKG

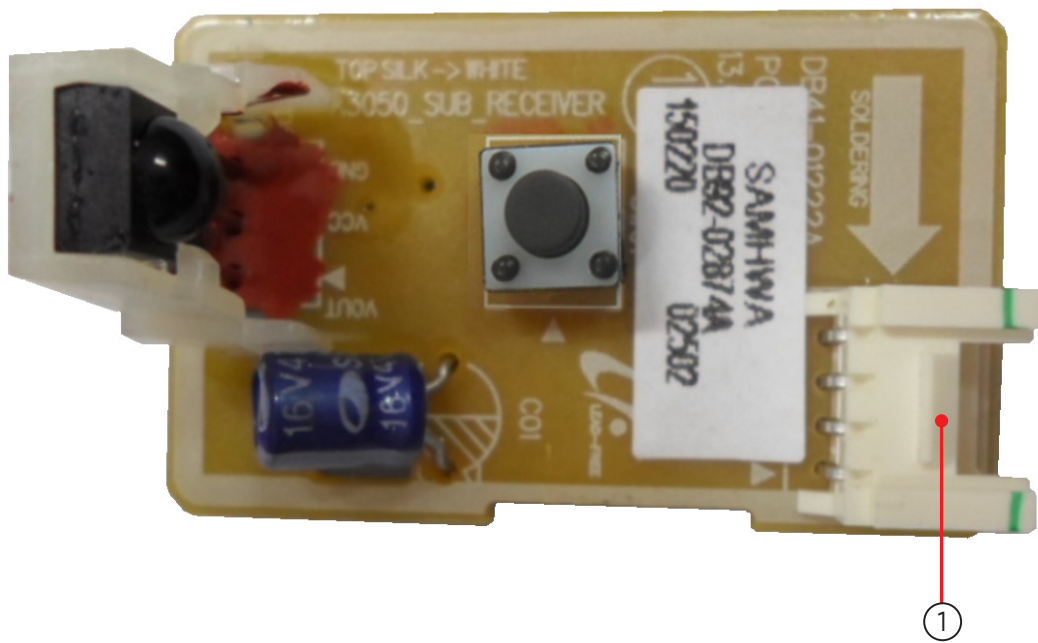

①	CN01-RECEIVER
#1:	GND
#2:	VOUT
#3:	VCC
#4:	S/W

5-1-6 Switch PCB

■ Console: AC***RNJDKG

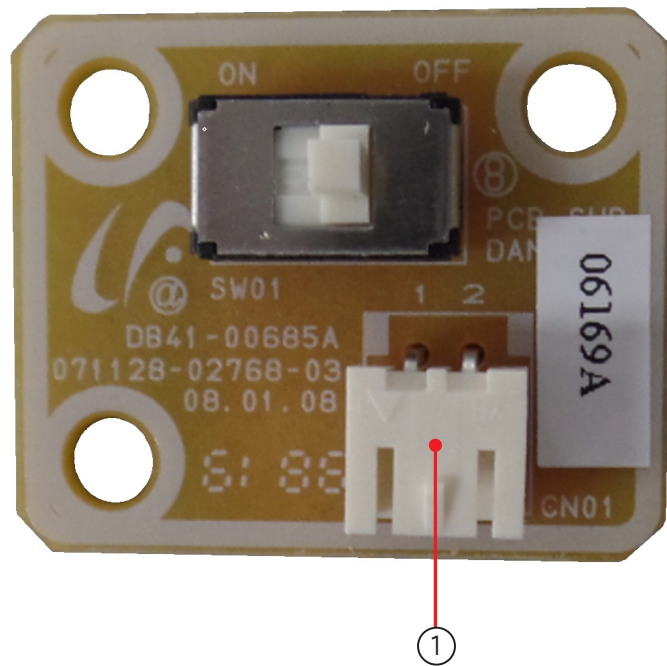

①	CN01 - DAMPER S/W
#1:	DAMPER S/W
#2:	GND

5-2 Outdoor Unit

5-2-1 MAIN PCB

■ AC026/035/052/071RXADKG

▶ Type A

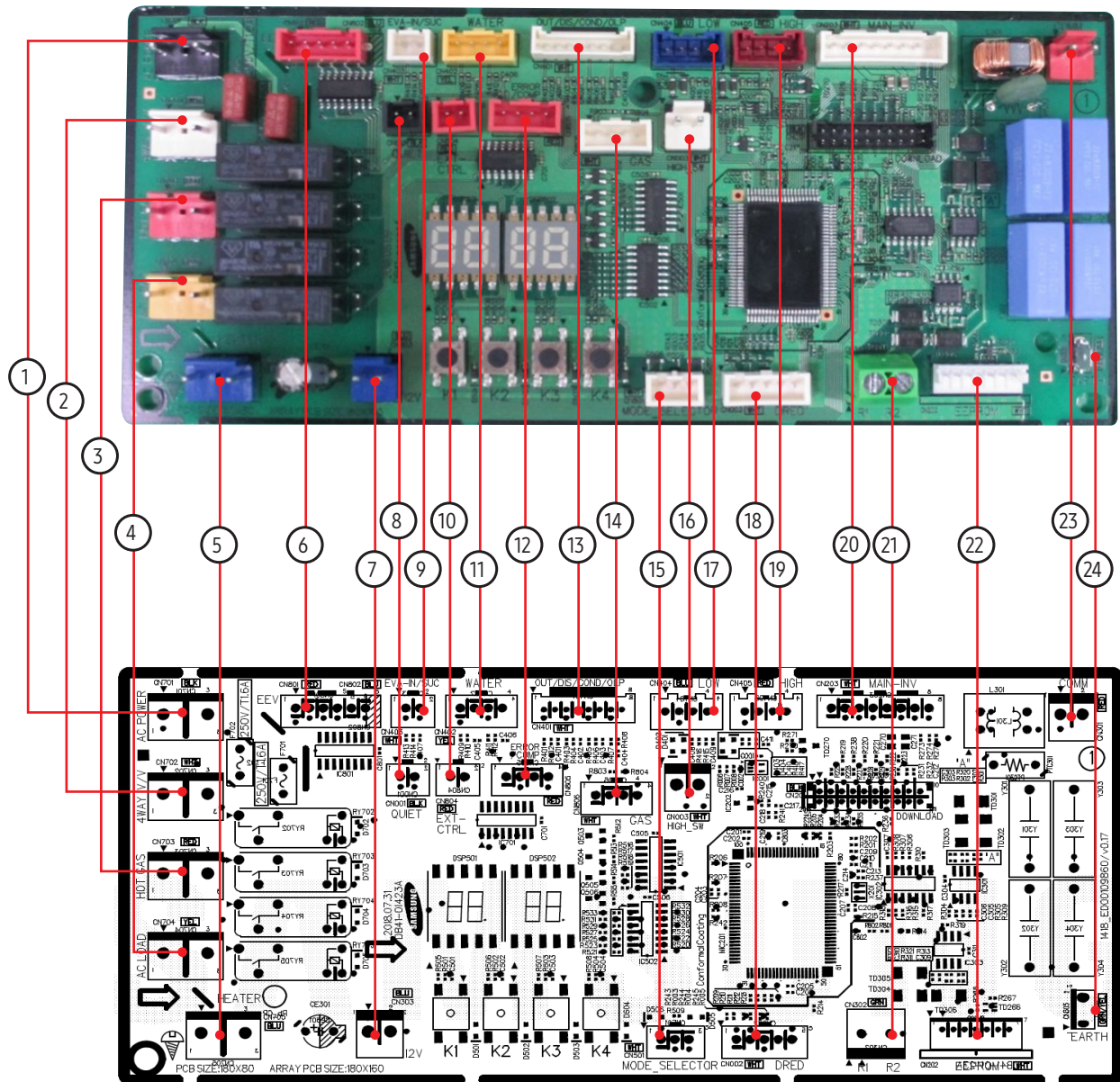

This Document can not be used without Samsung's authorization.

① CN701-AC POWER #1: L #2: - #3: N	② CN702-4WAY #1: N #2: - #3: L/ RELAY CONTACT	③ CN703-HOT GAS (AC LOAD) #1: N #2: - #3: L/ RELAY CONTACT	④ CN704-AC LOAD (AC LOAD) #1: N #2: - #3: L/ RELAY CONTACT
⑤ CN705-BASE HEATER (AC LOAD) #1: N #2: - #3: L/ RELAY CONTACT	⑥ CN801/CN802-EEV CAM/EDM #1: EEV A #2: EEV B #3: EEV A BAR #4: EEV B BAR #5, 6: 12V	⑦ CN303-DC 12V #1: DC12V #2: GND	⑧ CN001-QUIET #1: DC5V #2: GND
⑨ CN403-EVA IN SUCTION #1: SUCTION SENSOR #2: GND	⑩ CN804-EXTERNAL #1: DC 12V #2: GND	⑪ CN402-WATER IN, OUT SENSOR #1: WATER IN SENSOR #3: WATER OUT SENSOR #2,4: GND	⑫ CN805-COMP, ERROR CHECK #1, 3: DC 12V #2: ERROR CHECK #2: COMP CHECK
⑬ CN401-THERMISTOR #1: OUTDOOR SENSOR #3: DISCHARGE SENSOR #5: COND SENSOR #7: EEV B BAR #2, 4, 6, 8: GND	⑭ CN806-GAS SENSOR #1: DC5V #2: GND #3: - #4: GAS SENSOR	⑮ CN501-MODE SELETOR #1, 3: GRID_1 #2: GRID_2	⑯ CN003-HIGH PRESSURE SWITH #1: DC5V #3: GND
⑰ CN404-LOW PRESSURE SENSOR #1: - #2: LOW PRESSURE SENSOR #3: GND #4: DC5V	⑱ CN405-HIGH PRESSURE SENSOR #1: - #2: HIGH PRESSURE SENSOR #3: GND #4: DC5V	⑲ CN002-DRED #1~3: DRED 1, 2, 3 #4: GND #5: DC5V	⑳ CN203-MAIN-INV COMM #1: TXD #2: RXD #3: DC5V #4: GND #5: DC12V #6: POWER CTRL #7: AC ON #8: AC LOAD2
㉑ CM302-SOLUTION #1: R1+ #2: R2-	㉒ CN202-EEPROM #1~7: EEPROM	㉓ CM301-INDOOR-OUTDOOR COMM #1: F1 #2: F2	㉔ CN305-EARTH #1: EARTH

■ AC026/035/052/071RXADKG (cont.)

▶ Type B

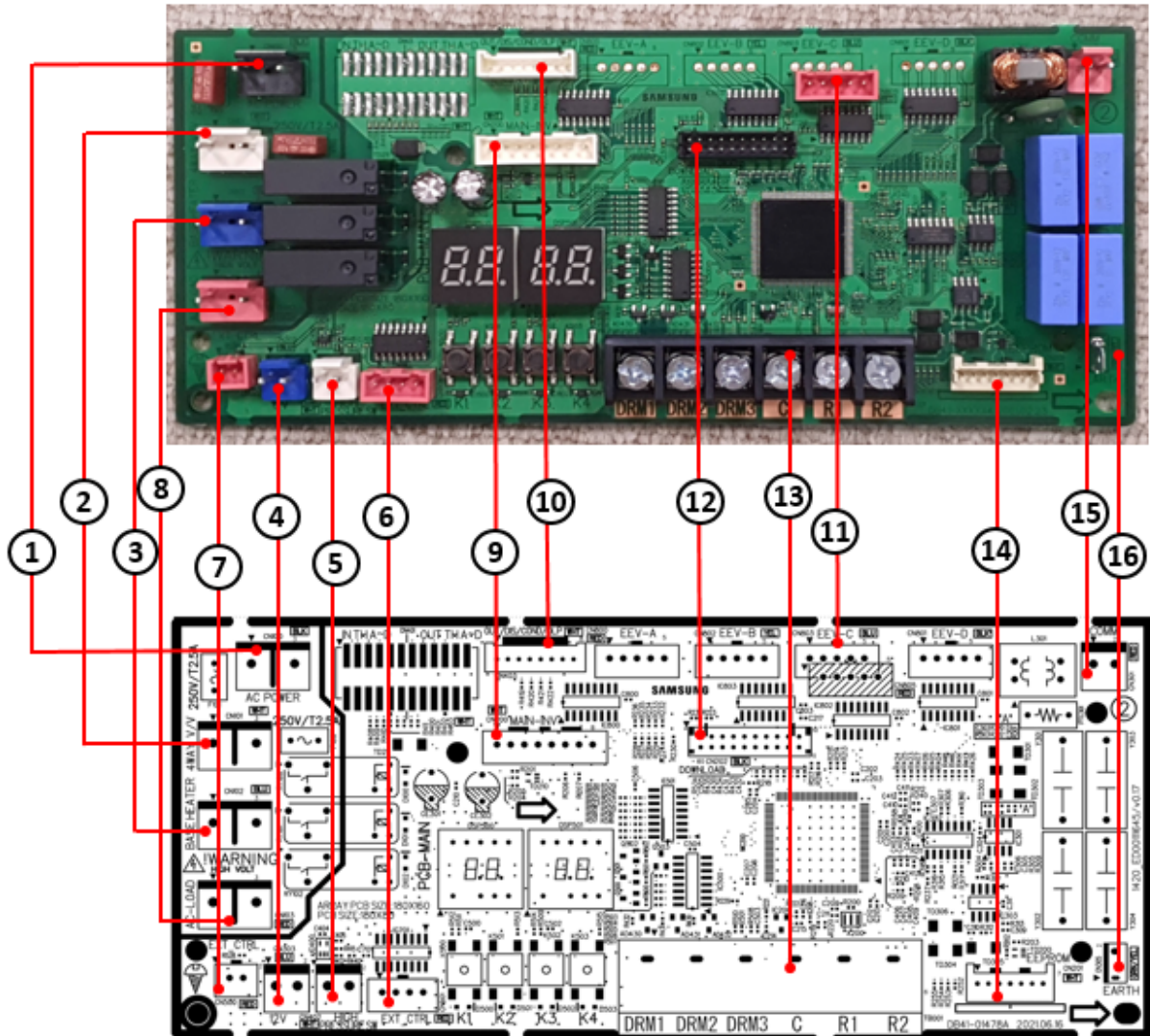

This Document can not be used without Samsung's authorization.

<p>① CN100-AC POWER #1: L-LIVE POWER INPUT #2: - #3: N-NEUTRAL POWER INPUT</p>	<p>② CN101-4WAY VALVE #1: L-L PHASE OUTPUT #2: #3: N-N PHASE OUTPUT</p>	<p>③ CN102-BASE HEATER #1: L-L PHASE OUTPUT #2: #3: N-N PHASE OUTPUT</p>	<p>④ CN303-DC12V #1: DC 12V #2: GND</p>
<p>⑤ CN402-HIGH PRESSURE SWITCH #1: HIGH PRESSURE SWITCH INPUT SIGNAL #2: GND</p>	<p>⑥ CN501-ERROR CHECK/ COMP CHECK #1: DC12V #2: ERROR CHECK #3: DC12V #4: COMP CHECK</p>	<p>⑦ CN500-EXTERNAL CONTROL #1: GND #2:EXTERNAL INPUT</p>	<p>⑧ CN103-BELT HEATER #1: L-L PHASE OUTPUT #2: #3: N-N PHASE OUTPUT</p>
<p>⑨ CN200-MAIN ↔ INV COMM #1: TXD #2: RXD #3: DC5V #4: GND #5: DC12V #6: INV POWER CTRL #7: MAIN AC LOAD POWER CTRL #8: -</p>	<p>⑩ CN403-THERMISTOR #1: OUTDOOR SENSOR #3: DISCHARGE SENSOR #5: CONDENSOR SENSOR #7: OLP SENSOR #2,4,6,8: GND</p>	<p>⑪ CN805-MAIN EEV #1: EEV C SIGNAL #2: EEV C SIGNAL #3: EEV C SIGNAL #4: EEV C SIGNAL #5: GND</p>	<p>⑫ CN202-DOWNLOAD #1-20: DOWNLOAD SIGNAL</p>
<p>⑬ TB001 #1: DRED SIGNAL(DRM1) #2: DRED SIGNAL(DRM2) #3: DRED SIGNAL(DRM3) #4: GND #5: R1 #6: R2</p>	<p>⑭ CN201-EEPROM #1: GND #2: - #3: 5V #4: EEPROM SIGNAL #5: EEPROM SIGNAL #6: EEPROM SIGNAL #7: EEPROM SIGNAL</p>	<p>⑮ CN301-ODU ↔ IDU COMM #1: F1 #2: F2</p>	<p>⑯ CN305-COMMUNICATION EMI EARTH #1: EARTH</p>

■ AC100/120/140RXAD*G

▶ Type A

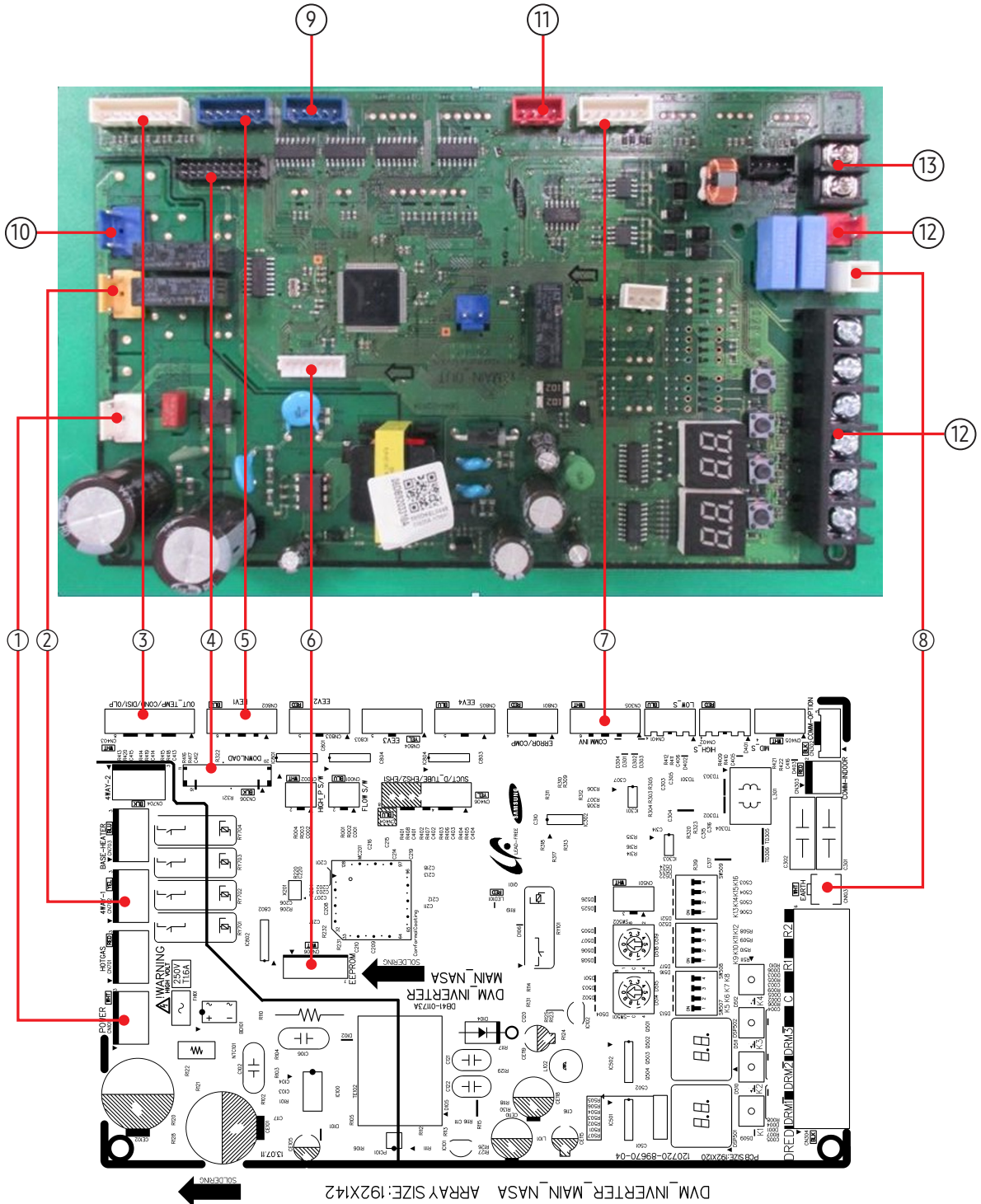

This Document can not be used without Samsung's authorization.

<p>① CN101 - POWER #1: AC POWER (N) #3: AC POWER (L)</p>	<p>② CN702 - 4WAY #1: AC POWER (N) #3: 4WAY POWER (L)</p>	<p>③ CN403 - SENSOR #1: OUTTEMP #2: GND #3: COND TEMP #4: GND #5: DISCHARGE TEMP #6: GND #7: OLP TEMP #8: GND</p>	<p>④ CN306 - DOWNLOAD</p>
<p>⑤ CN802 - EEV #1 ~ #4: EEV SIGNAL #5,#6: DC 12V</p>	<p>⑥ CN806 - EEPROM #1: GND #3: DC 5V #4: EEPROM_SELECT #5: EEPROM_SO #6:EEPROM_SI #7: EEPROM_CLK</p>	<p>⑦ CN305 - COMM INV #1: TXD_INVERTER #2: RXD_INVERTER #3: GND #4: DC5V #5: DC12V #6: INV_INRUSH_OUT</p>	<p>⑧ CN103 - EARTH #1: EARTH</p>
<p>⑨ [REDACTED] #1~#4: EEV SIGNAL #5: DC12V</p>	<p>⑩ [REDACTED] #1: AC POWER (N) #3: BASE HEATER POWER (L)</p>	<p>⑪ [REDACTED] #1: DC12V #2: ERROR SIGNAL OUTPUT (GND) #3: DC12V #4: COMP/OPER. SIGNAL OUTPUT (GND)</p>	<p>⑫ [REDACTED] #1: COM2 (F3) #2: COM2 (F4)</p>
<p>⑬ [REDACTED] #1: QUITE SWITCH #2: GND</p>	<p>⑭ [REDACTED] #1: DRM1 #2: DRM2 #3: DRM3 #4: GND #5: COMM (R1) #6: COMM (R2)</p>		

■ AC100/120/140RXAD*G (cont.)

▶ Type B

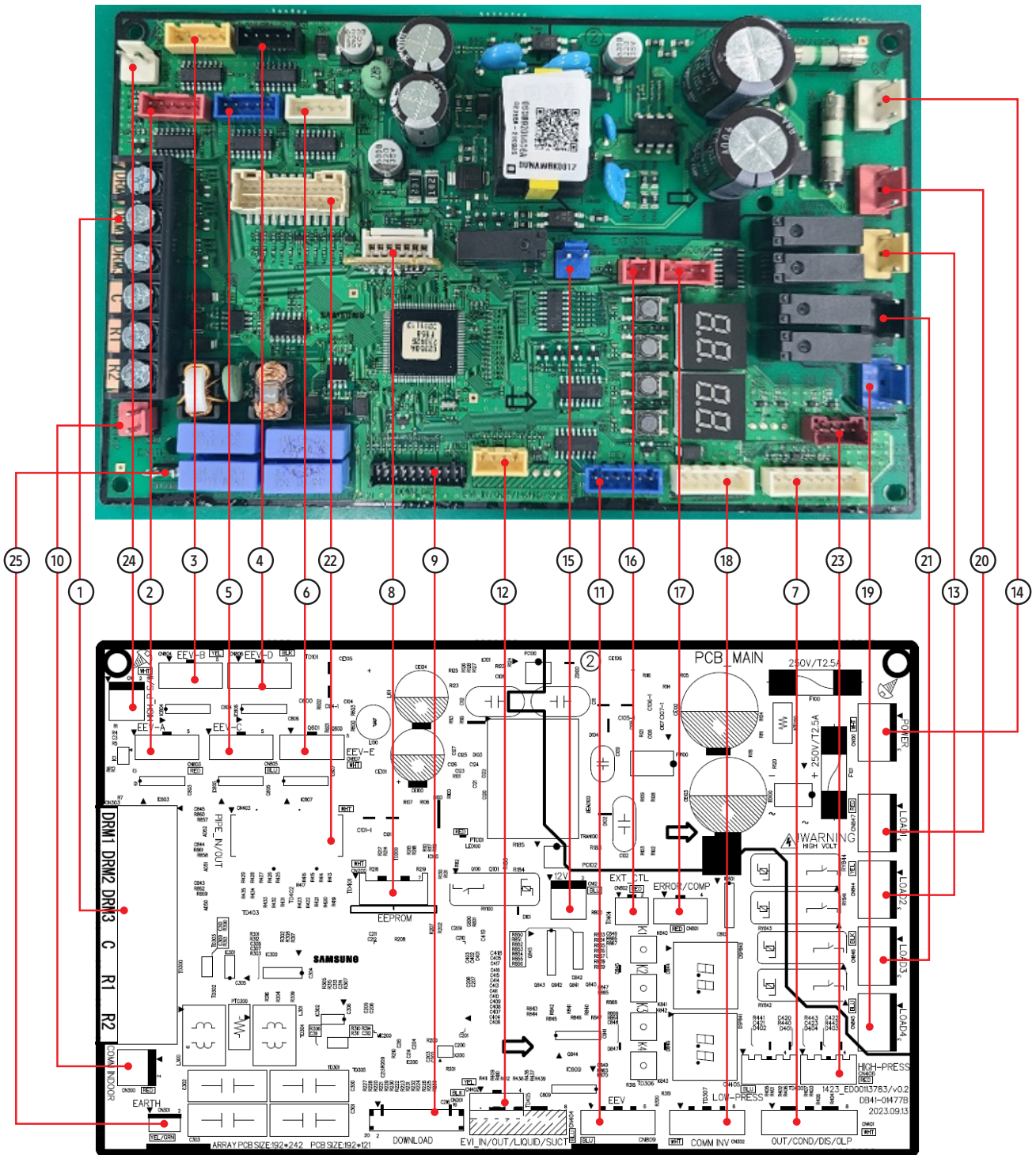

This Document can not be used without Samsung's authorization.

<p>① CN303 - DRED & UPPER CTRL #1: DRED SIGNAL (DRM1) #2: DRED SIGNAL (DRM2) #3: DRED SIGNAL (DRM3) #4: GND #5: R1 #6: R2</p>	<p>② CN803 - EEV A #1: EEV A SIGNAL #2: EEV A SIGNAL #3: EEV A SIGNAL #4: EEV A SIGNAL #5: GND</p>	<p>③ CN804 - EEV B #1: EEV B SIGNAL #2: EEV B SIGNAL #3: EEV B SIGNAL #4: EEV B SIGNAL #5: GND</p>	<p>④ CN806 - EEV D #1: EEV D SIGNAL #2: EEV D SIGNAL #3: EEV D SIGNAL #4: EEV D SIGNAL #5: GND</p>
<p>⑤ CN805 - MAIN EEV #1: EEV D SIGNAL #2: EEV D SIGNAL #3: EEV D SIGNAL #4: EEV D SIGNAL #5: GND</p>	<p>⑥ CN807 - EEV E #1: EEV A SIGNAL #2: EEV A SIGNAL #3: EEV A SIGNAL #4: EEV A SIGNAL #5: GND</p>	<p>⑦ CN401 - TEMPERATURE SENSOR #1: OUTDOOR TEMPERATURE SENSOR #3: DISCHARGE TEMPERATURE SENSOR #5: CONDENSOR TEMPERATURE SENSOR #7: OLP TEMPERATURE SENSOR #2,4,6,8: GND</p>	<p>⑧ CN200 - EEPROM #1: GND #2: - #3: 5V #4: EEPROM SIGNAL #5: EEPROM SIGNAL #6: EEPROM SIGNAL #7: EEPROM SIGNAL</p>
<p>⑨ CN306 - DOWNLOAD #1~20: DOWNLOAD SIGNAL</p>	<p>⑩ CN303 - ODU ↔ IDU COMMUNICAITON #1: F1 #2: F2</p>	<p>⑪ CN809 - MAIN EEV (EDM) #1: EEV A SIGNAL #2: EEV A SIGNAL #3: EEV A SIGNAL #4: EEV A SIGNAL #5: GND</p>	<p>⑫ CN402 - TEMPERATURE SENSOR #1: ESC IN TEMPERATURE SENSOR #3: ESC OUT TEMPERATURE SENSOR #2,4: GND</p>
<p>⑬ CN844 - 4WAY VALVE #1: L - RELAY CONTACT OUTPUT #2: - #3: N - NEUTRAL POWER OUTPUT</p>	<p>⑭ CN101 - AC POWER INPUT #1: L - LIVE POWER INPUT #2: - #3: N - NEUTRAL POWER INPUT</p>	<p>⑮ CN12 - DC12V #1: 12V #2: GND</p>	<p>⑯ CN800-EXTERNAL CONTROL #1: GND #2: EXTERNAL CONTROL INPUT SIGNAL</p>
<p>⑰ CN801 - ERROR CHECK/ COMP CHECK #1: DC 12V #2: ERROR CHECK #3: DC 12V #4: COMP CHECK</p>	<p>⑱ CN302 - MAIN ↔ INV COMMUNICAITON #1: TXD #2: RXD #3: GND #4: DC 5V #5: DC 12V #6: INV POWER CTRL</p>	<p>⑲ CN845 - BASE HEATER #1: L - RELAY CONTACT OUTPUT #2: - #3: N - NEUTRAL POWER OUTPUT</p>	<p>⑳ CN847 - AC-LOAD #1: L - RELAY CONTACT OUTPUT #2: - #3: N - NEUTRAL POWER OUTPUT</p>
<p>㉑ CN846 - EVI V/V #1: L - LIVE POWER INPUT #2: - #3: N - NEUTRAL POWER INPUT</p>	<p>㉒ CN401 - PIPE TEMPERTURE SENSOR #1~#10: PIPE IN TEMPERATURE SENSOR #13~#22: PIPE OUT TEMPERATURE SENSOR</p>	<p>㉓ CN405 - HIGH PRESSURE SENSOR #1: HIGH PRESSURE SENSING #3: GND #4: 5V</p>	<p>㉔ CN1 - HIGH PRESSURE SWITCH #1: HIGH PRESSURE SENSING #2: GND</p>
<p>㉕ CN301 - EARTH #1: EARTH</p>			

5-2-2 INVERTER PCB

■ PF#2: AC026/035RXADKG

▶ Type A

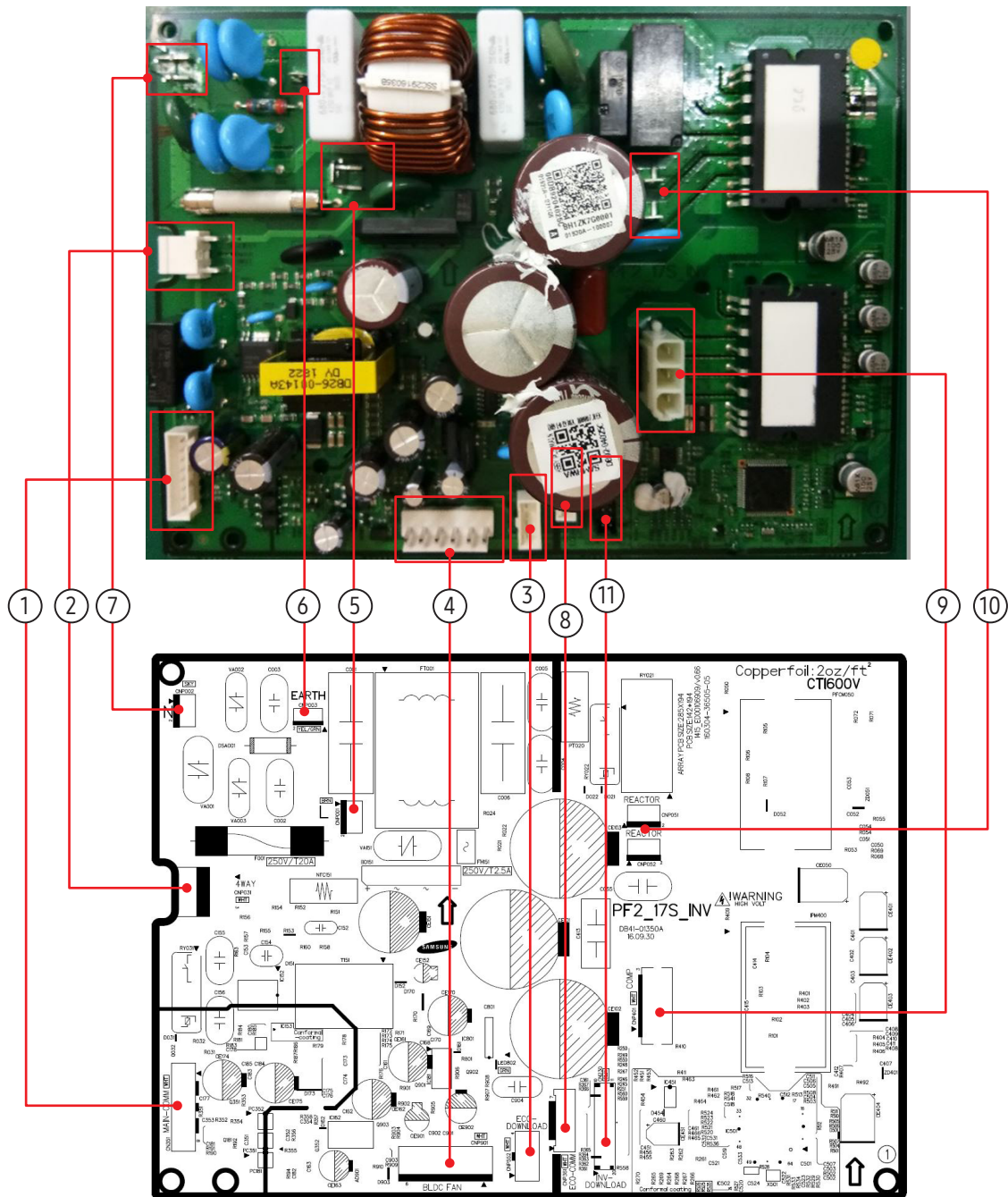

This Document can not be used without Samsung's authorization.

<p>① CN351 - MAIN INV. COMM #1: RXD #2: TXD #3: DC5V #4: GND #5: DC12V #6: POWER CTRL #7: 4WAY (AC LOAD) #8: -</p>	<p>② CNP031 - MAIN POWER #1: N #2: - #3: L</p>	<p>③ CNP552 - ECO DOWNLOAD #1: RXD_INV #2: TXD_INV #3: GND #4: DC5V</p>	<p>④ CNP901 #1: DC310V #2: - #3: GND #4: DC15V #5: V_sp #6: F/B</p>
<p>⑤ CNP001 - L/TAP TERMINAL #1: L</p>	<p>⑥ CNP003 - EARTH/TAP TERMINAL #1: EARTH</p>	<p>⑦ CNP002 - N/TAP TERMINAL #1: N</p>	<p>⑧ CNP361 - ECO DOWNLOAD #1~#7: ECO COMM PART</p>
<p>⑨ CNP401 - COMP #1: W Phase #2: V Phase #3: U Phase</p>	<p>⑩ CNP051,CNP052 - REACTOR #1: REACTOR</p>	<p>⑪ DOWNLOAD #1~#20: DOWNLOAD</p>	

► Type B

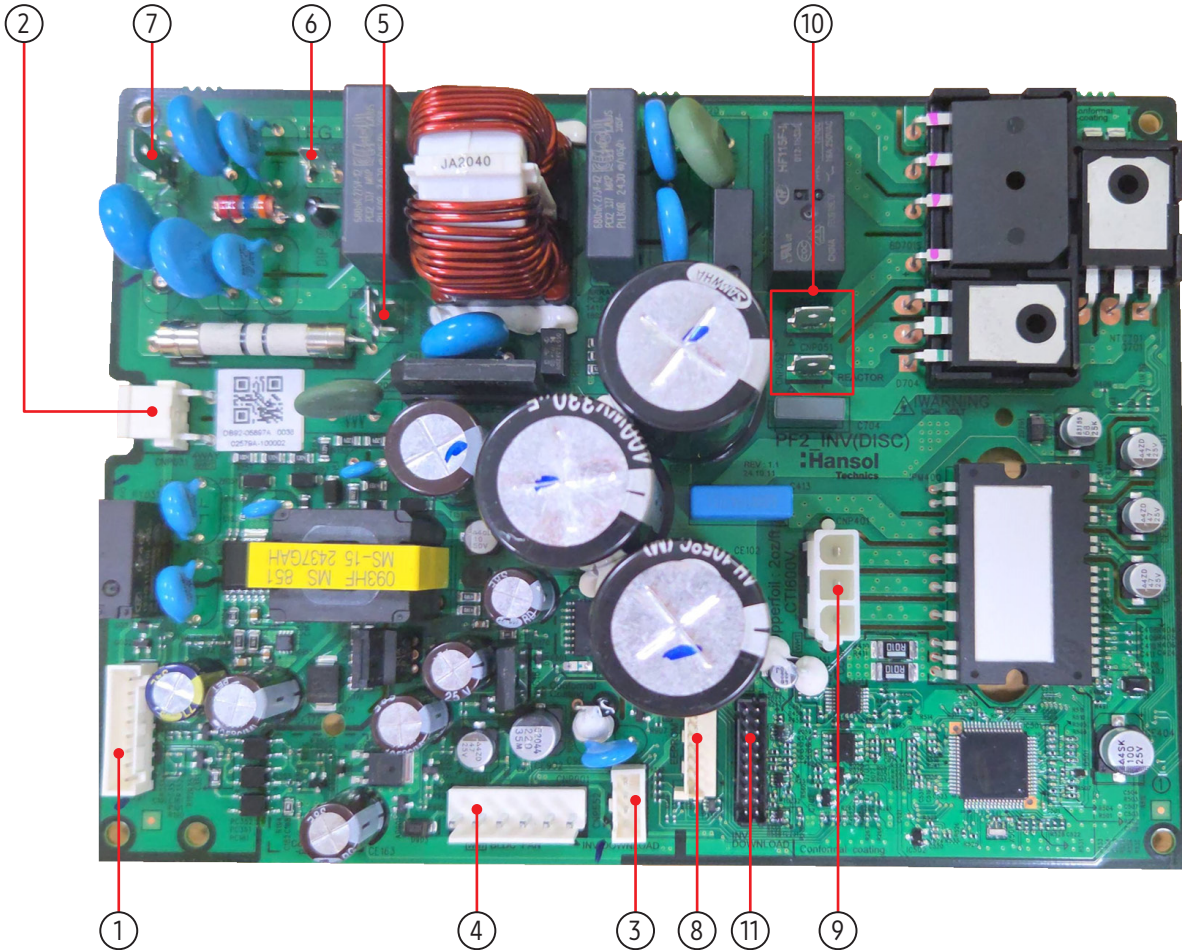

<p>① CNP351-MAIN INV #1: RXD #2: TXD #3: DC5V #4: GND #5: DC12V #6: POWER CTRL #7: AC LOAD #8: AC LOAD2</p>	<p>② CNP031-MAIN POWER #1: N #2: - #3: L</p>	<p>③ CNP552-ECO DOWNLOAD #1~4: ECO DOWNLOAD</p>	<p>④ CNP901-BLDC FAN #1: DC310V #2: - #3: PGND #4: DC15V #5: V_SP #6: F/B</p>
<p>⑤ CNP001-L/TAP TERMINAL #1: L</p>	<p>⑥ CNP003-EARTH/TAP TERMINAL #1: EARTH</p>	<p>⑦ CNP002-N/TAP TERMINAL #1: N</p>	<p>⑧ CN361-ECO DOWNLOAD #1~7: ECO COMM PART</p>
<p>⑨ CNP401-COMP #1: U,RED #2: V,BLU #3: W,YEL</p>	<p>⑩ CNP051, CNP052-REACTOR #CNP051, 052: REACTOR</p>	<p>⑪ CN230-INV DOWNLOAD #1~20: DOWNLOAD</p>	

This Document can not be used without Samsung's authorization.

■ PF#3: AC052/071RXADKG

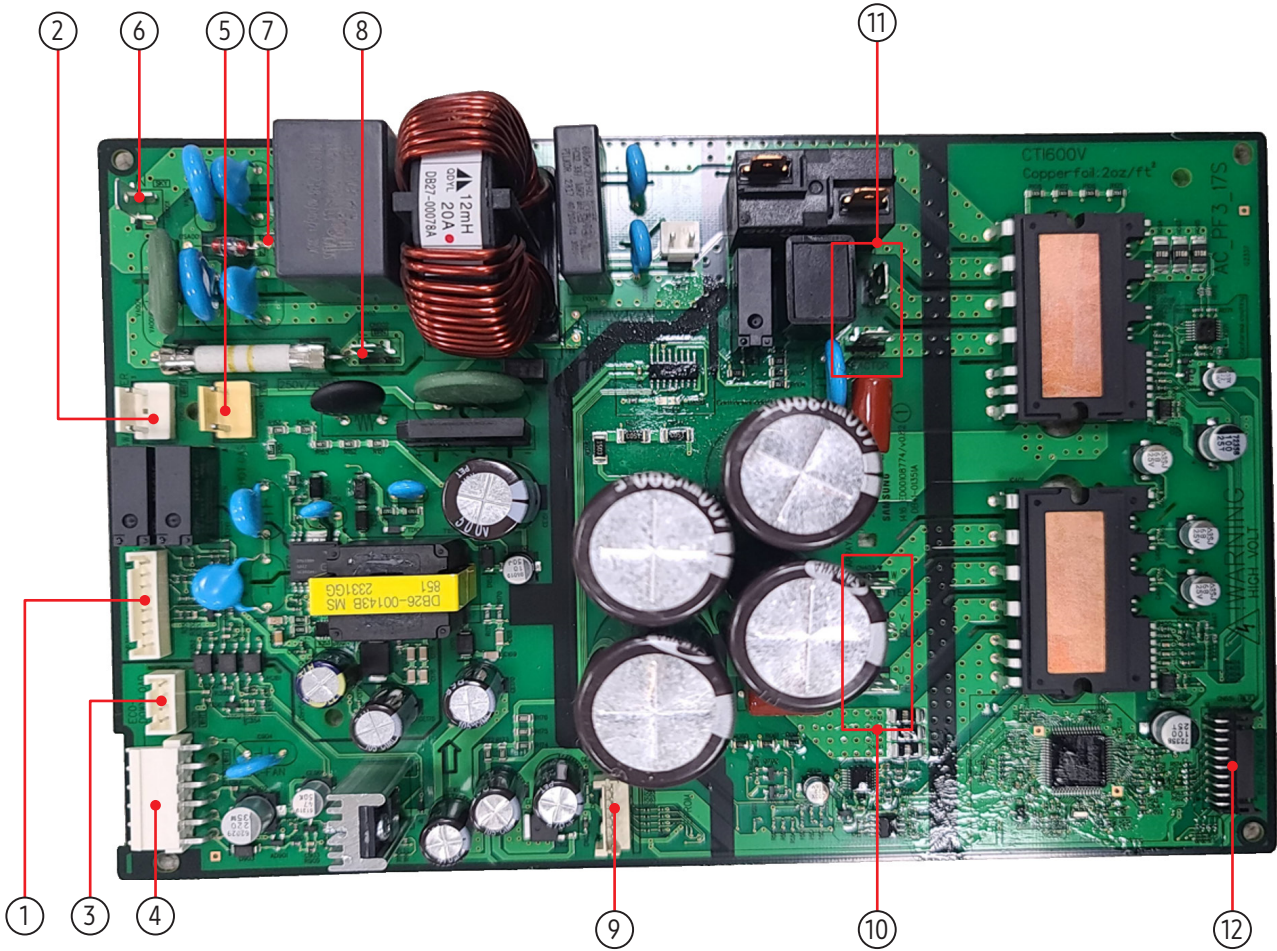

<p>① CNP351-MAIN INV #1: RXD #2: TXD #3: DC5V #4: GND #5: DC12V #6: POWER CTRL #7: AC LOAD #8: AC LOAD2</p>	<p>② CN030-MAIN POWER #1: N #2: - #3: L</p>	<p>③ CN571-ECO DOWNLOAD #1~4: ECO DOWNLOAD</p>	<p>④ CNP901- BLDC FAN #1: DC310V #2: - #3: PGND #4: DC15V #5: V_SP #6: F/B</p>
<p>⑤ CN241-HOT GAS (AC LOAD) #1: L/ RELAY CONTACT #2: - #3: N</p>	<p>⑥ CN001-N/ TAP TERMINAL #1: N</p>	<p>⑦ CN571-EARTH TAP TERMINAL #1: EARTH</p>	<p>⑧ CN002-L/ TAP TERMINAL #1: L</p>
<p>⑨ CN581-ECO COMM #1~7: ECO COMM port</p>	<p>⑩ CN401, 402, 403-COMP #CN401: U, RED #CN402: V, BLU #CN403: W, YEL</p>	<p>⑪ CN051, 052-REACTOR #CN501,052: REACTOR</p>	<p>⑫ CN551-DOWNLOAD #1~20: DOWNLOAD</p>

This Document can not be used without Samsung's authorization.

■ PF#4: AC100/120RXADKG

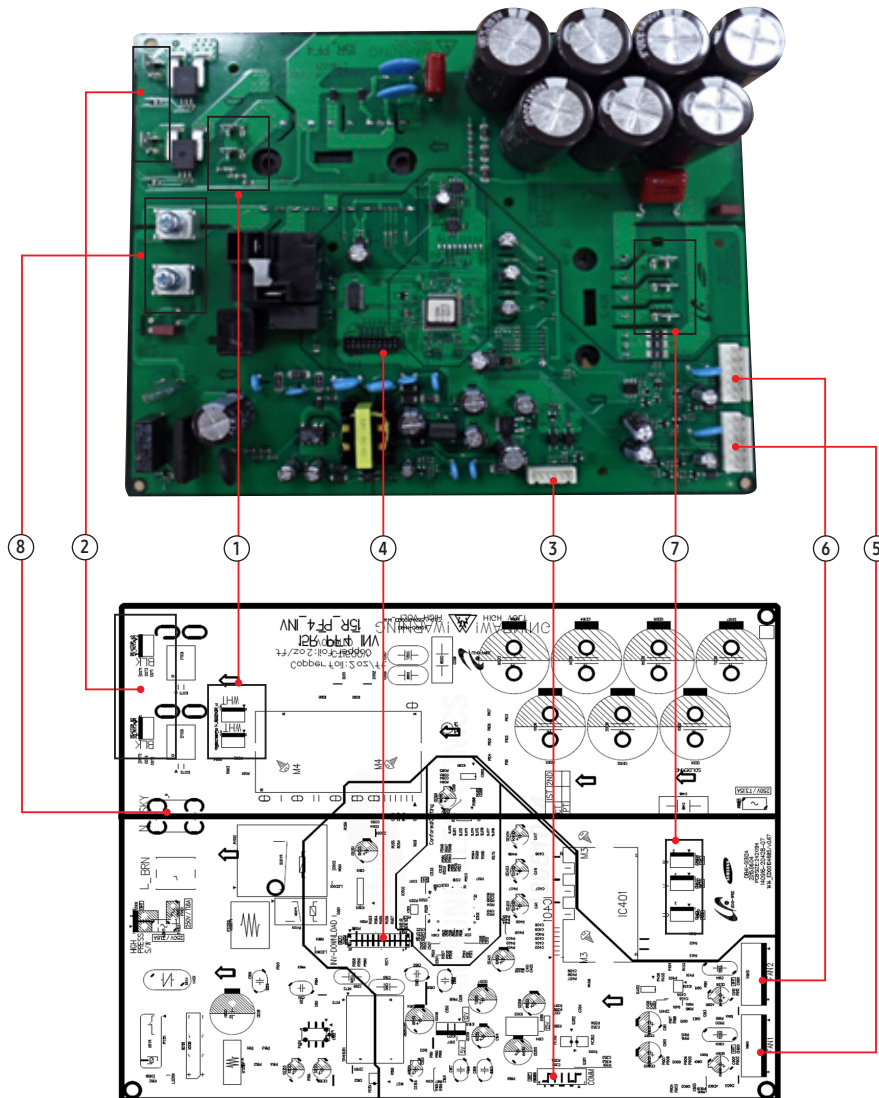

<p>① REACTOR: A1/B1 #REACTOR - A1:WHT #REACTOR - B1: WHT</p>	<p>② REACTOR: A2/B2 #REACTOR - A2: BLK #REACTOR - B2: BLK</p>	<p>③ CN351: Main COMM #1: RXD #2: TXD #3: GND #4: DC 5V #5: DC 12V #6: INV,SMPS SIGNAL</p>	<p>④ CN551: DOWNLOAD</p>
<p>⑤ CN901: Fan 1 #1: DC 310V #3: GND #4: DC 15V #5: FAN RPM #6: FAN RPM FEEDBACK</p>	<p>⑥ CN911: Fan 2 #1: DC 310V #3: GND #4: DC 15V #5: FAN RPM #6: FAN RPM FEEDBACK</p>	<p>⑦ CN401: COMP #1: COMP-U PHASE #2: COMP-V PHASE #3: COMP-W PHASE</p>	<p>⑧ L_N: AC POWER #L_BRN: AC POWER (L)/BRN #N_SKY: AC POWER (N)/SKY</p>

This Document can not be used without Samsung's authorization.

■ PF#5: AC140RXADKG

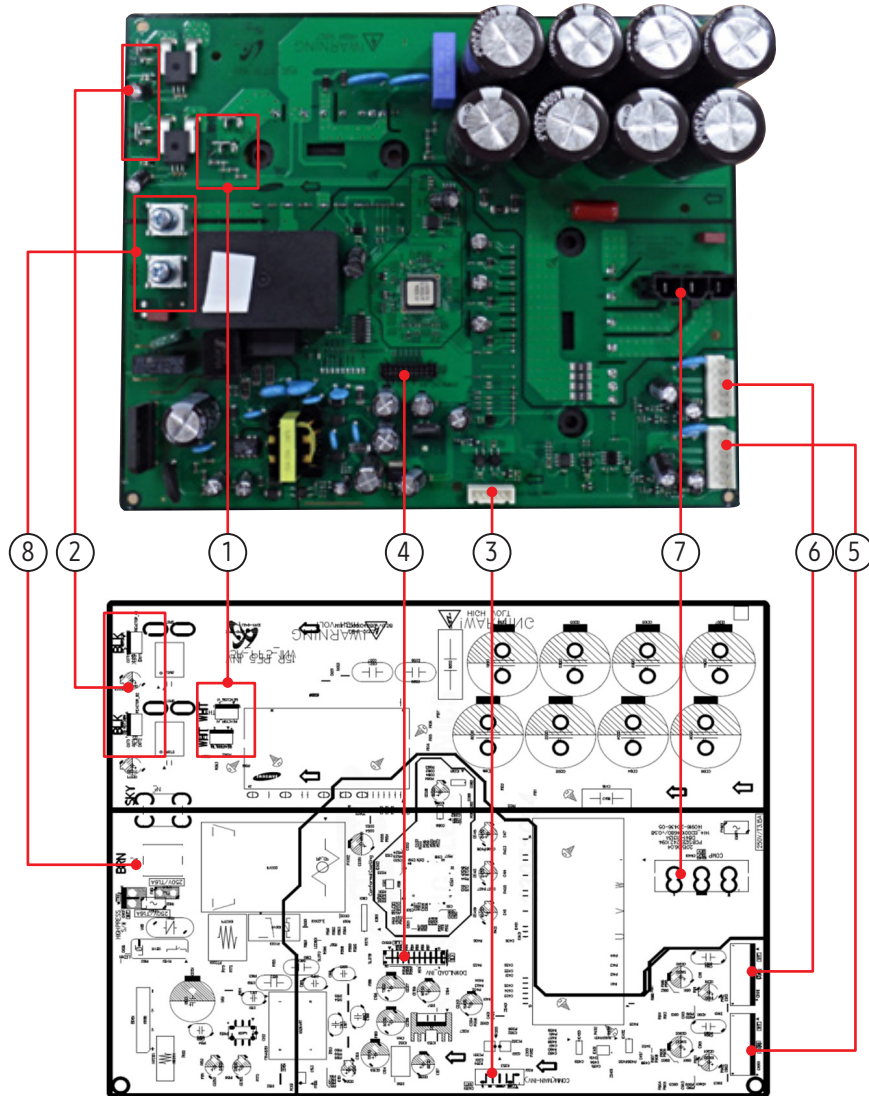

<p>① REACTOR: A1/B1 #REACTOR - A1:WHT #REACTOR - B1: WHT</p>	<p>② REACTOR: A2/B2 #REACTOR - A2: BLK #REACTOR - B2: BLK</p>	<p>③ CN351: Main COMM #1: RXD #2: TXD #3: GND #4: DC 5V #5: DC 12V #6: INV,SMPS SIGNAL</p>	<p>④ CN551: DOWNLOAD</p>
<p>⑤ CN901: Fan 1 #1: DC 310V #3: GND #4: DC 15V #5: FAN RPM #6: RPM FEEDBACK</p>	<p>⑥ CN911: Fan 2 #1: DC 310V #3: GND #4: DC 15V #5: FAN RPM #6:RPM FEEDBACK</p>	<p>⑦ CN401: COMP #1: COMP-U PHASE #2: COMP-V PHASE #3: COMP-W PHASE</p>	<p>⑧ L,N: AC POWER L_: AC POWER (L) N_: AC POWER (N)</p>

This Document can not be used without Samsung's authorization.

■ PF#6-1: AC100RXADNG

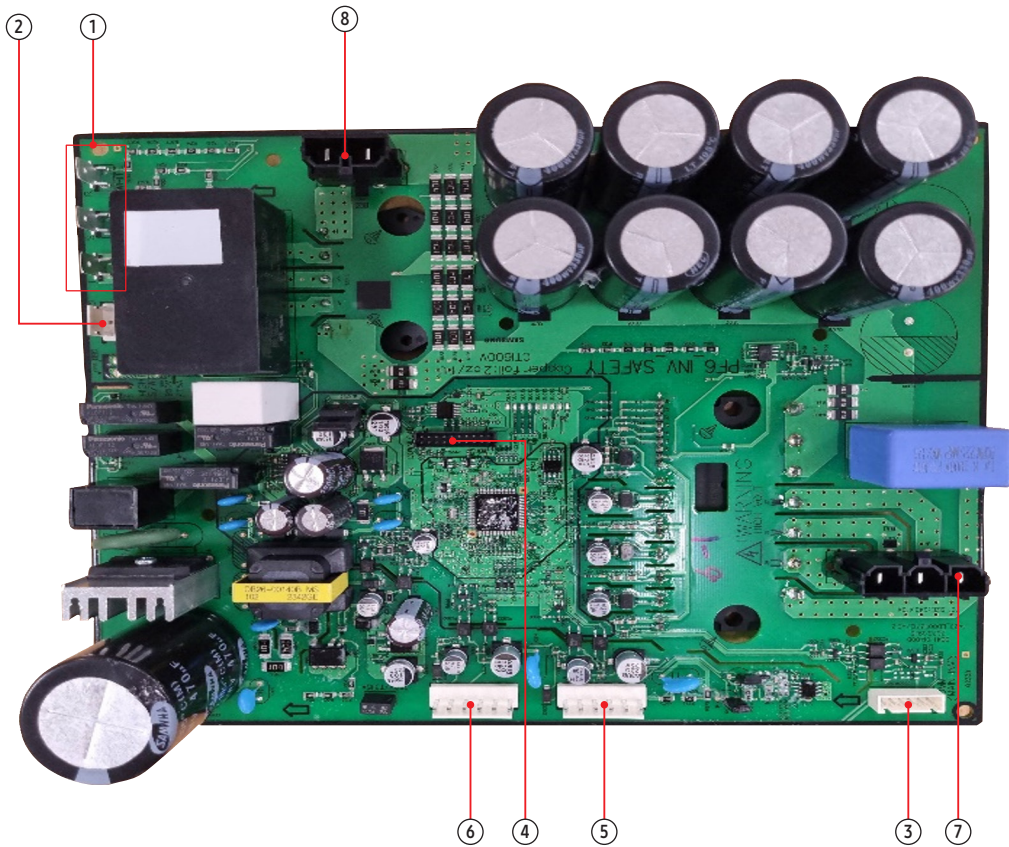

<p>① RST-AC INPUT 3Phase #R: AC 380~400V: WHT #S: AC 380~400V: BRN #T: AC 380~400V: BLK</p>	<p>② CN100-AC POWER #1: L_POWER #3: N_POWER</p>	<p>③ CN31-MAIN COMM #1: RXD #2: TXD #3: GND #4: DC 5V #5: DC 12V #6: SMPS RELAY</p>	<p>④ CN22-DOWNLOAD</p>
<p>⑤ CN900-BLDC MOTOR 1 #1: DC310V #3: GND #4: DC15V #5: FAN RPM #6: RPM FEEDBACK</p>	<p>⑥ CN901-BLDC MOTOR 2 #1: DC310V #3: GND #4: DC15V #5: FAN RPM #6: RPM FEEDBACK</p>	<p>⑦ CN400-COMP #1: U-phase #2: V-phase #3: W-phase</p>	<p>⑧ CN101-REACTOR #1: REACTOR #2: REACTOR</p>

This Document can not be used without Samsung's authorization.

■ PF#6: AC120/140RXADNG

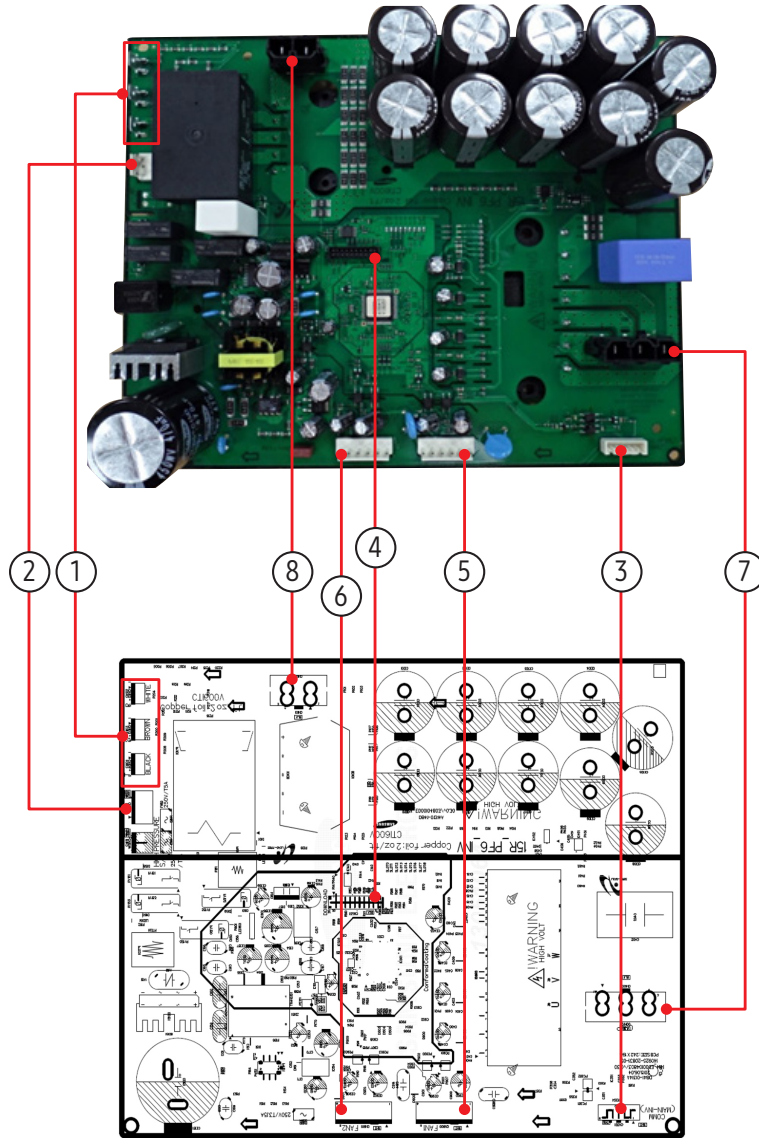

<p>① REACTOR: A1/B1 #REACTOR - A1: WHT #REACTOR - B1: WHT</p>	<p>② REACTOR: A2/B2 #REACTOR - A2: BLK #REACTOR - B2: BLK</p>	<p>③ CN351: Main COMM #1: RXD #2: TXD #3: GND #4: DC 5V #5: DC 12V #6: INV,SMPS SIGNAL</p>	<p>④ CN551: DOWNLOAD</p>
<p>⑤ CN901: Fan 1 #1: DC 310V #3: GND #4: DC 15V #5: FAN RPM #6: RPM FEEDBACK</p>	<p>⑥ CN911: Fan 2 #1: DC 310V #3: GND #4: DC 15V #5: FAN RPM #6: RPM FEEDBACK</p>	<p>⑦ CN401: COMP #1: COMP-U PHASE #2: COMP-V PHASE #3: COMP-W PHASE</p>	<p>⑧ L,N: AC POWER #L_: AC POWER (L) #N_: AC POWER (N)</p>

This Document can not be used without Samsung's authorization.

5-2-3 EMI PBA

■ AC100/120/140RXADKG

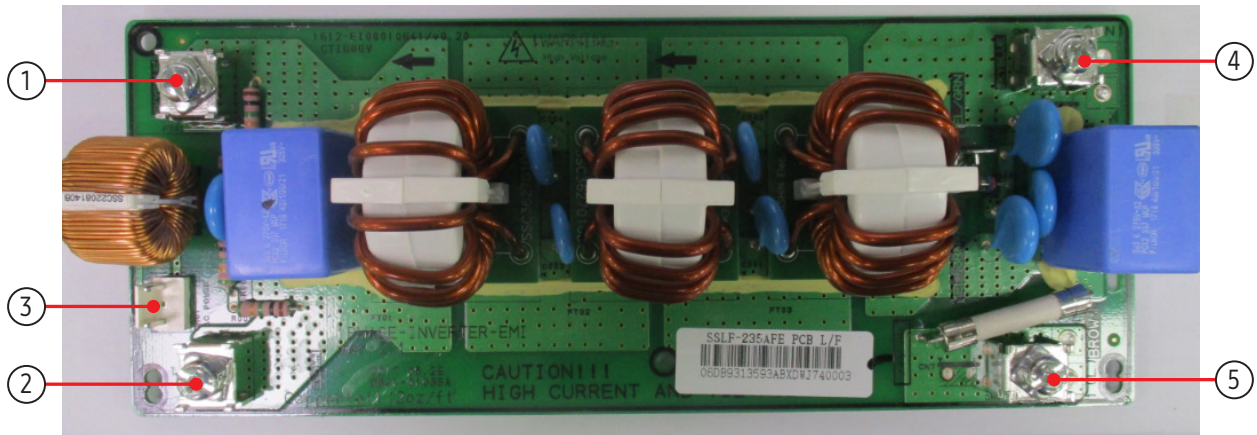

<p>① N1: AC POWER(N) #1: AC POWER (N)</p>	<p>② L1: AC POWER(L) #1: AC POWER (L)</p>	<p>③ CN01: POWER #1: AC POWER (L) #3: AC POWER (N)</p>	<p>④ CN5: AC POWER (N) #1: AC POWER (N)</p>
<p>⑤ CN4: AC POWER (L) #1: AC POWER (L)</p>			

This Document can not be used without Samsung's authorization.

■ AC100/120/140RXADNG

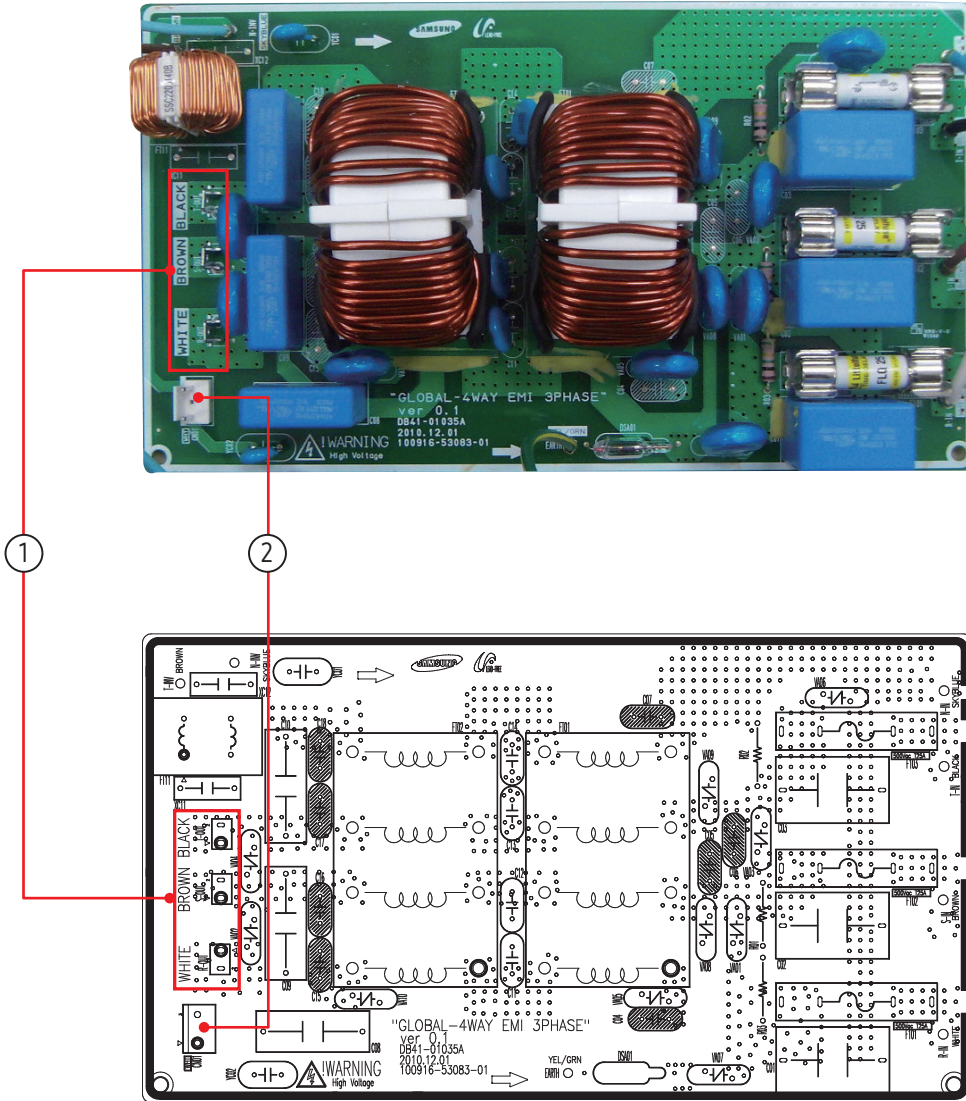

<p>① RST: AC Power 3phase #R: AC 380~400V: WHT #S: AC 380~400V: BRN #T: AC 380~400V: BLK</p>	<p>② CN01: AC Power #1-#3: AC 220~240V</p>
--	--

This Document can not be used without Samsung's authorization.

6. Wiring Diagram

6-1 Indoor Unit

■ 1Way: AC026/035RN1DKG

▶ Type A

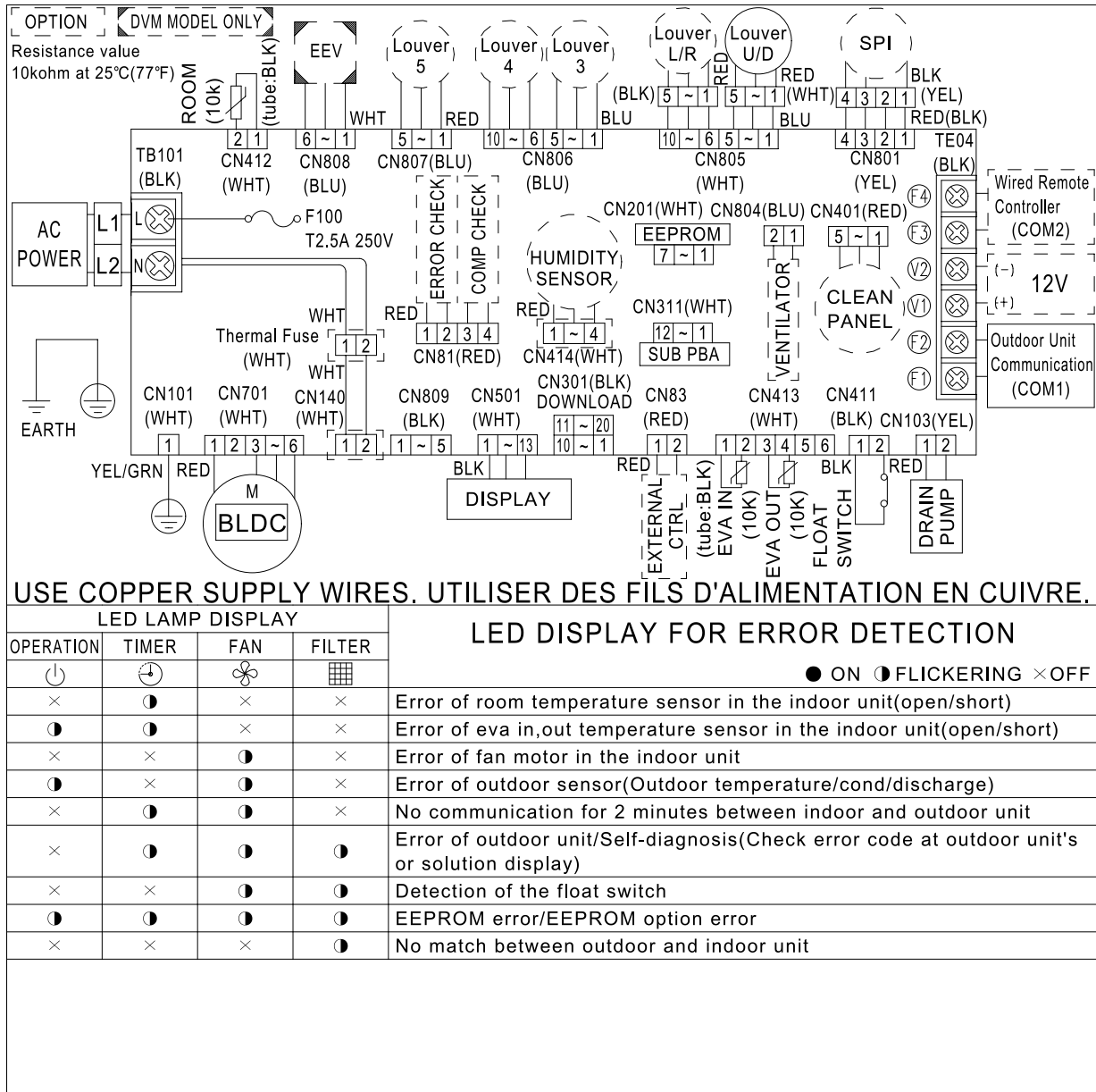

This Document can not be used without Samsung's authorization.

Indoor Unit (cont.)

■ 1Way: AC026/035RN1DKG (cont.)

▶ Type B

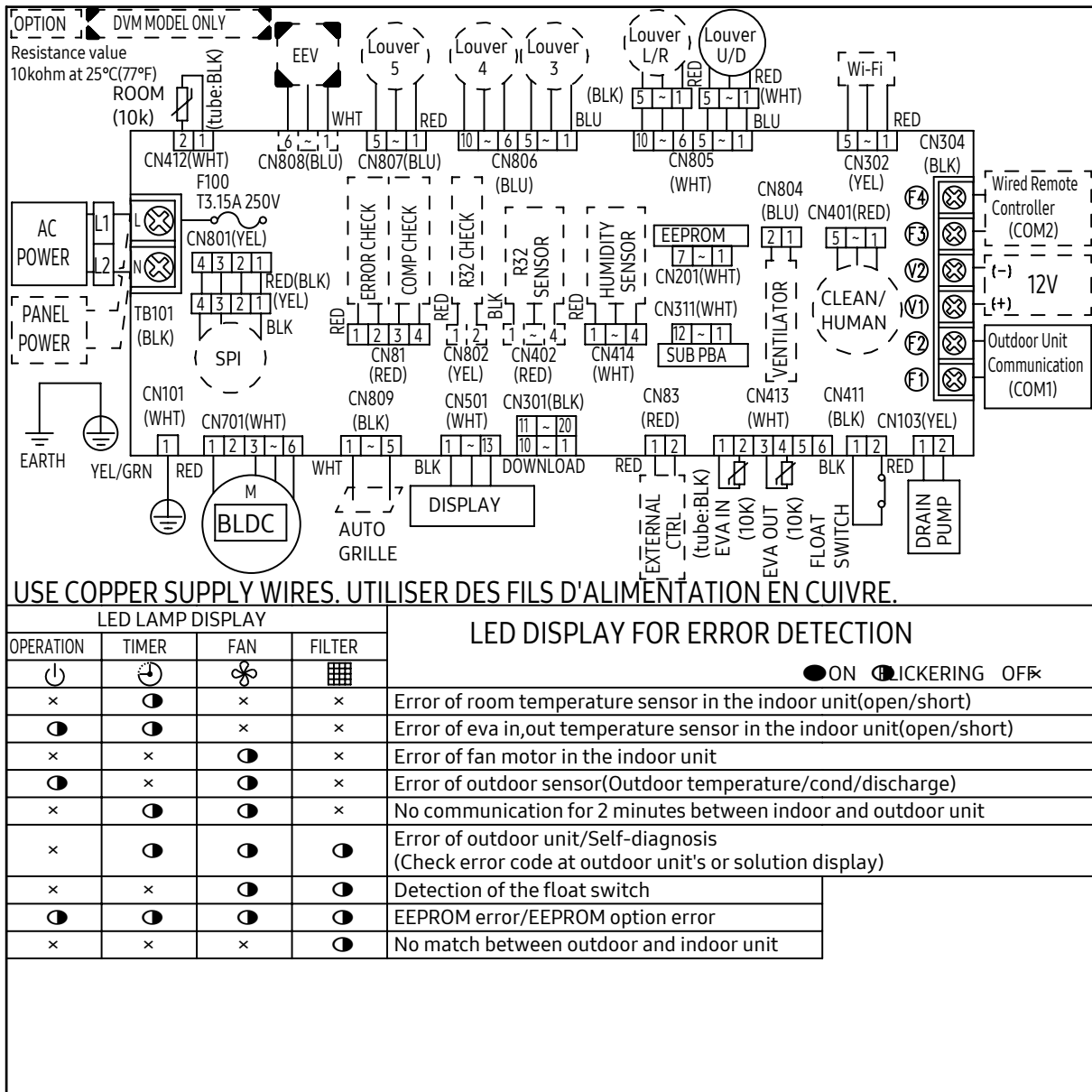

This Document can not be used without Samsung's authorization.

Indoor Unit (cont.)

- Mini 4Way CST: AC026/035/052/071RNNDKG
- ▶ Type A

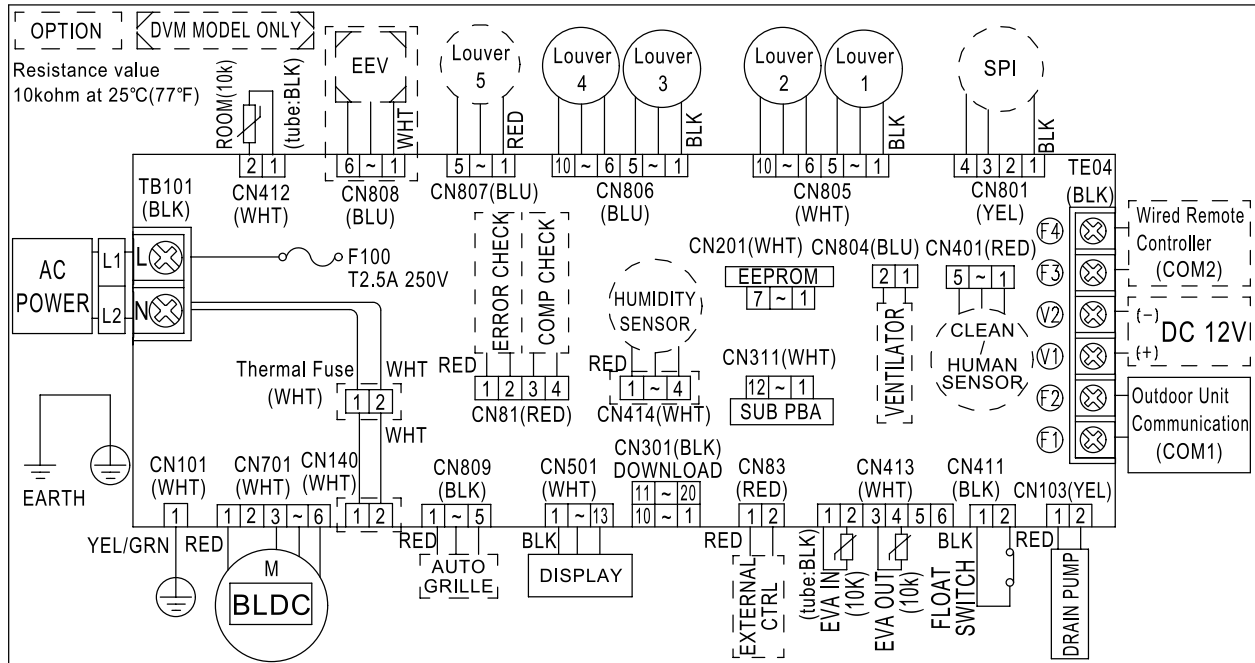

USE COPPER SUPPLY WIRES. UTILISER DES FILS D'ALIMENTATION EN CUIVRE.

LED LAMP DISPLAY				LED DISPLAY FOR ERROR DETECTION
OPERATION	DEFROST	TIMER	FILTER	
				● ON ○ FLICKERING × OFF
×	○	×	×	Error of room temperature sensor in the indoor unit(open/short)
○	○	×	×	Error of eva in,out temperature sensor in the indoor unit(open/short)
×	×	○	×	Error of fan motor in the indoor unit
○	×	○	×	Error of outdoor sensor(Outdoor temperature/cond/discharge)
×	○	○	×	No communication for 2 minutes between indoor and outdoor unit
×	○	○	○	Error of outdoor unit/Self-diagnosis (Check error code at outdoor unit's or solution display)
×	×	○	○	Detection of the float switch
○	○	○	○	EEPROM error/EEPROM option error
○	×	×	○	MDS (Motion Detecting Sensor) Error
○	○	×	○	No match between outdoor and indoor unit
○	×	○	○	High Pressure Blockage Error (Only CAC Model)

This Document can not be used without Samsung's authorization.

Indoor Unit (cont.)

■ Mini 4Way CST: AC026/035/052/071RNNDKG (cont.)

▶ Type B

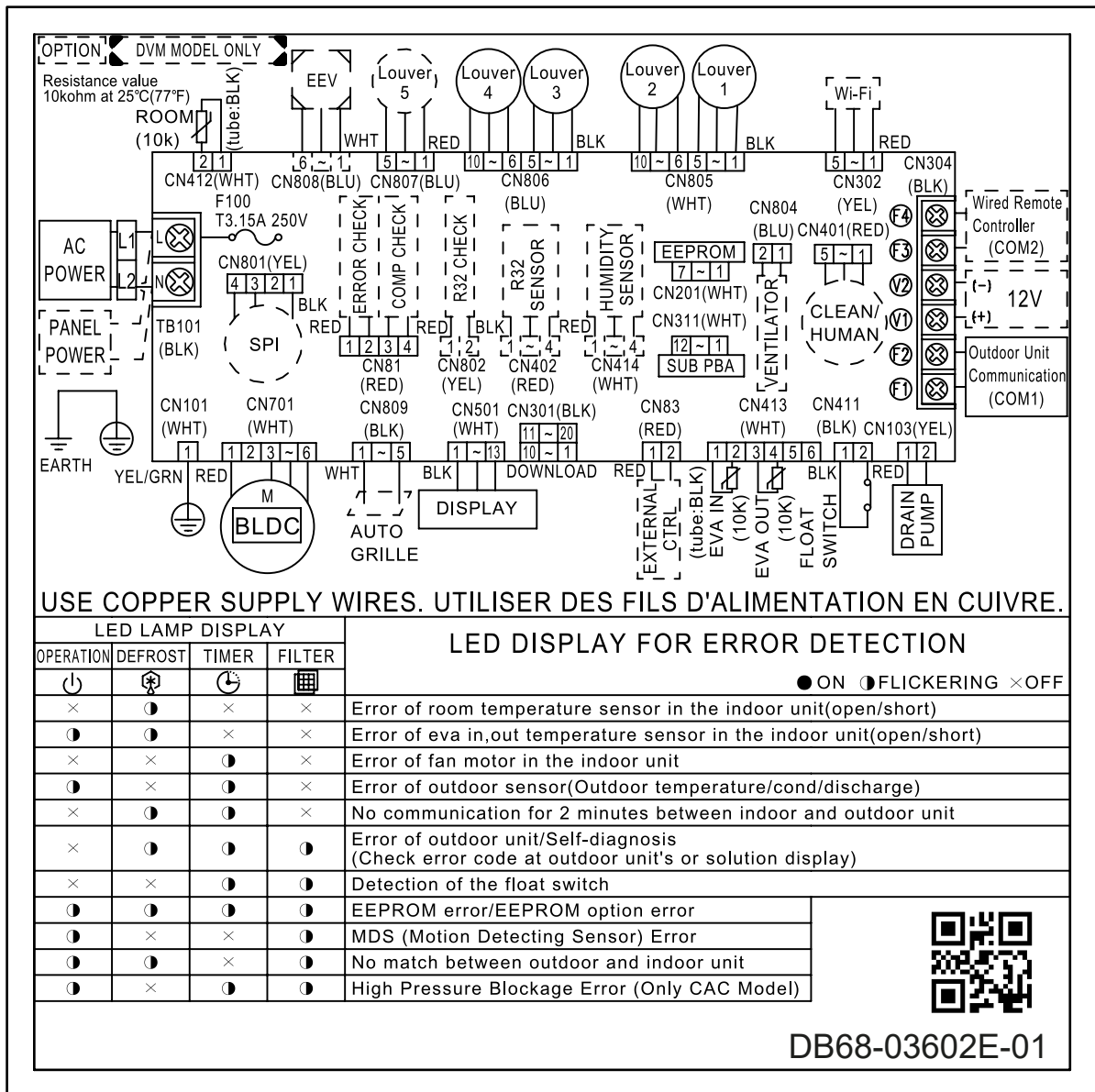

Indoor Unit (cont.)

■ 4Way CST : AC052/071/100/120/140RN4DKG (cont.)

▶ Type B

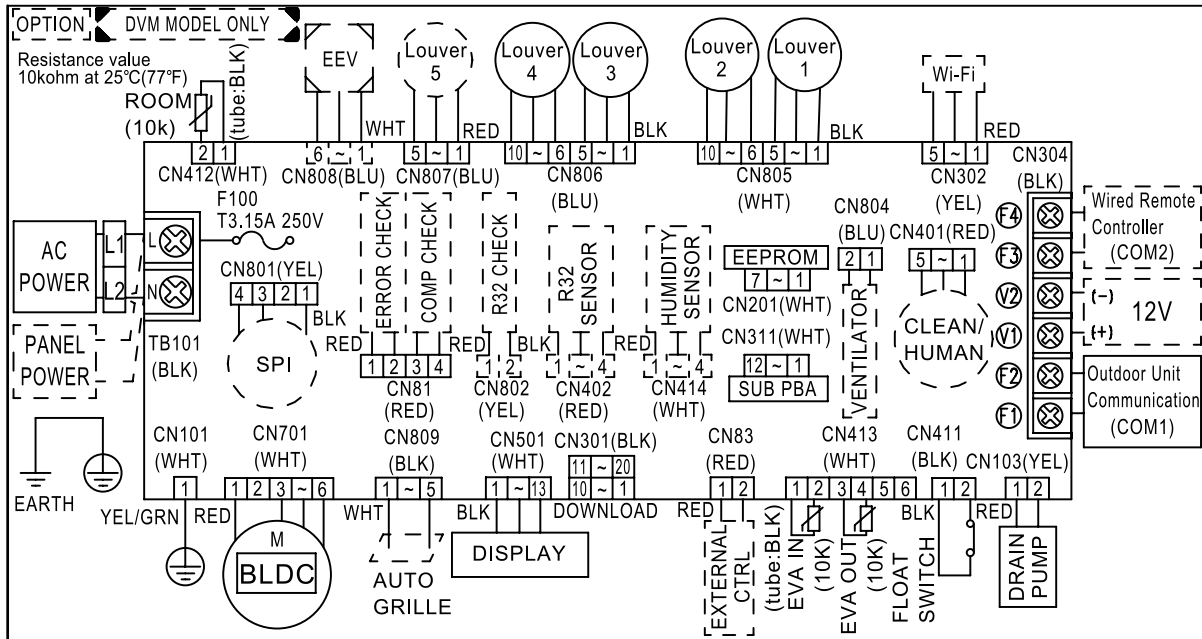

USE COPPER SUPPLY WIRES. UTILISER DES FILS D'ALIMENTATION EN CUIVRE.

LED LAMP DISPLAY				LED DISPLAY FOR ERROR DETECTION
OPERATION	DEFROST	TIMER	FILTER	
				● ON ○ FLICKERING × OFF
×	○	×	×	Error of room temperature sensor in the indoor unit(open/short)
○	○	×	×	Error of eva in,out temperature sensor in the indoor unit(open/short)
×	×	○	×	Error of fan motor in the indoor unit
○	×	○	×	Error of outdoor sensor(Outdoor temperature/cond/discharge)
×	○	○	×	No communication for 2 minutes between indoor and outdoor unit
×	○	○	○	Error of outdoor unit/Self-diagnosis (Check error code at outdoor unit's or solution display)
×	×	○	○	Detection of the float switch
○	○	○	○	EEPROM error/EEPROM option error
○	×	×	○	MDS (Motion Detecting Sensor) Error
○	○	×	○	No match between outdoor and indoor unit
○	×	○	○	High Pressure Blockage Error (Only CAC Model)

Indoor Unit (cont.)

■ 360 CST: AC071/100/120/140RN4PKG

▶ Type A

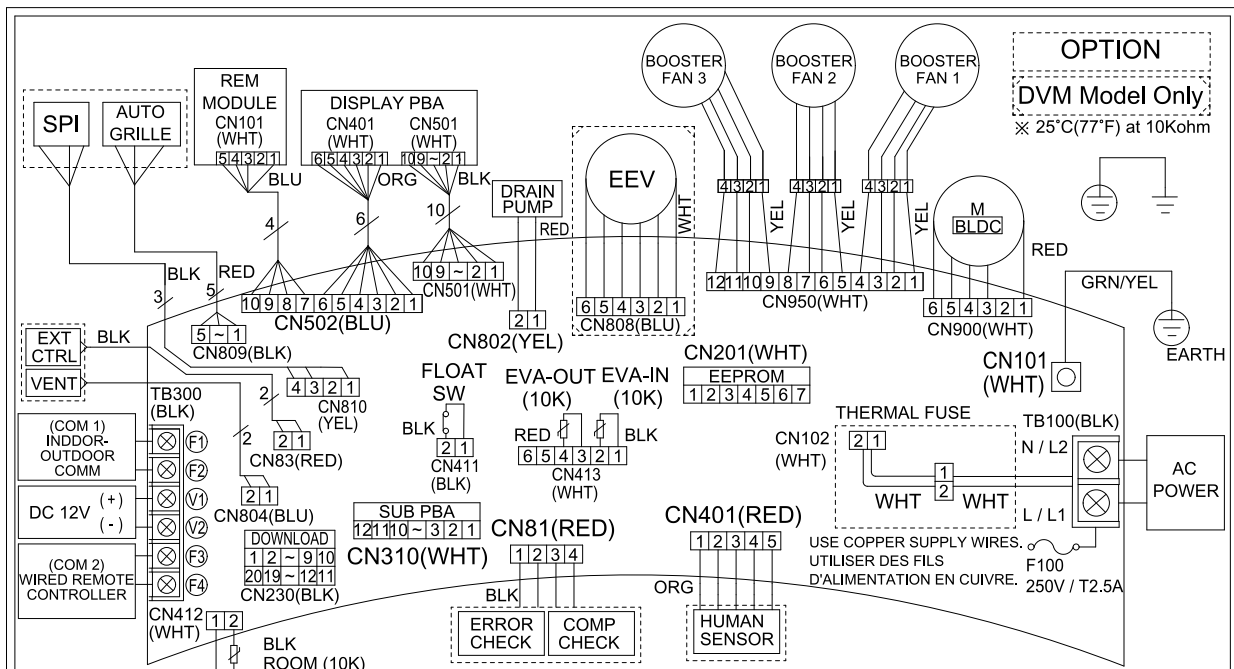

LED LAMP DISPLAY ● On ● Flickering	LED DISPLAY FOR ERROR DETECTION	LED LAMP DISPLAY ● On ● Flickering	LED DISPLAY FOR ERROR DETECTION
● ICE BLUE	Operating	● RED	Smart Install Error (Only CAC Model)
● ICE BLUE	Power Reset (Flickering every 2 seconds)	● RED - GRN Alternation of Flickering	Error of EVA- IN / OUT / DISCHARGE Sensor In the Indoor Unit (Open/short)
● ICE BLUE	Defrosting Operation (Flickering every 10 Seconds)	● RED - BLU Alternation of Flickering	Error of Fan Motor In the Indoor Unit
● BLU	Reserving Mode	● GRN - BLU Alternation of Flickering	Detection of the Float Switch
● GRN	Filter Usage Expiration	● ICE BLU - BLU Alternation of Flickering	Detection of the Thermal Fuse Open
● RED	Error of Room Sensor In the Indoor Unit (Open/short)	● ICE BLU - RED Alternation of Flickering	Miss Matching Of Indoor and Outdoor Unit (Only DVM Model)
● BLU	Error Of Outdoor Unit	● ICE BLU - GRN Alternation of Flickering	Miss Matching Of Indoor and Outdoor Unit (Only DVM Model)
● GRN	No Communication For 2 Minutes Between Indoor and Outdoor Unit	● RED - ICE BLU - GRN Alternation of Flickering	Error of EEPROM
● RED-ICE BLU-GRN Alternation of Flickering	Error of Motion Detecting Sensor		

This Document can not be used without Samsung's authorization.

Indoor Unit (cont.)

■ 360 CST: AC071/100/120/140RN4PKG (cont.)

▶ Type B

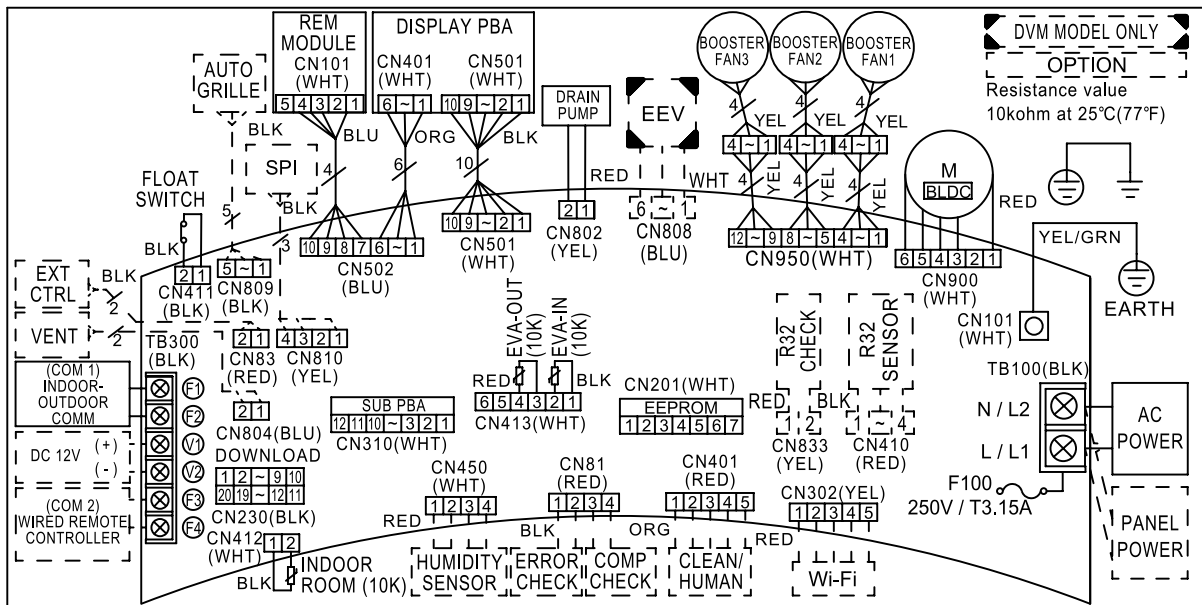

USE COPPER SUPPLY WIRES. UTILISER DES FILS D'ALIMENTATION EN CUIVRE.

LED LAMP DISPLAY ● ON ● FLICKERING	LED DISPLAY FOR ERROR DETECTION	LED LAMP DISPLAY ● ON ● FLICKERING	LED DISPLAY FOR ERROR DETECTION
● ICE BLUE	Operation	● RED	Smart Install Error(Only CAC Model)
○ ICE BLUE	Power Reset (Flickering every 2 seconds)	○ RED ↔ GREEN	Error of EVA- IN / OUT / DISCHARGE Sensor In the Indoor Unit (Open/short)
○ ICE BLUE	Defrosting Operation (Flickering every 10 Seconds)	○ RED ↔ BLUE	Error of Fan Motor In the Indoor Unit
● BLUE	Reserving Mode	○ GREEN ↔ BLUE	Detection of the Float Switch
● GREEN	Filter Usage Expiration	○ ICE BLUE ↔ BLUE	Detection of the Thermal Fuse Open
○ RED	Error of Room Sensor In the Indoor Unit (Open/short)	○ ICE BLUE ↔ RED	Miss Matching Of Indoor and Outdoor Unit (Only DVM Model)
○ BLUE	Error Of Outdoor Unit/Self-diagnosis (Check error code at outdoor unit's or solution display)	○ ICE BLUE ↔ GREEN	Error of Mixed Operation
○ GREEN	No Communication For 2 Minutes Between Indoor and Outdoor Unit	○ ICE BLUE ↔ GREEN ↔ RED	EEPROM error / EEPROM option error
○ ICE BLUE ↔ GREEN ↔ BLUE	Error of Motion Detecting Sensor	↔ : Alternation of Flickering	

Indoor Unit (cont.)

■ Duct: AC026/035/052/071RNLDKG

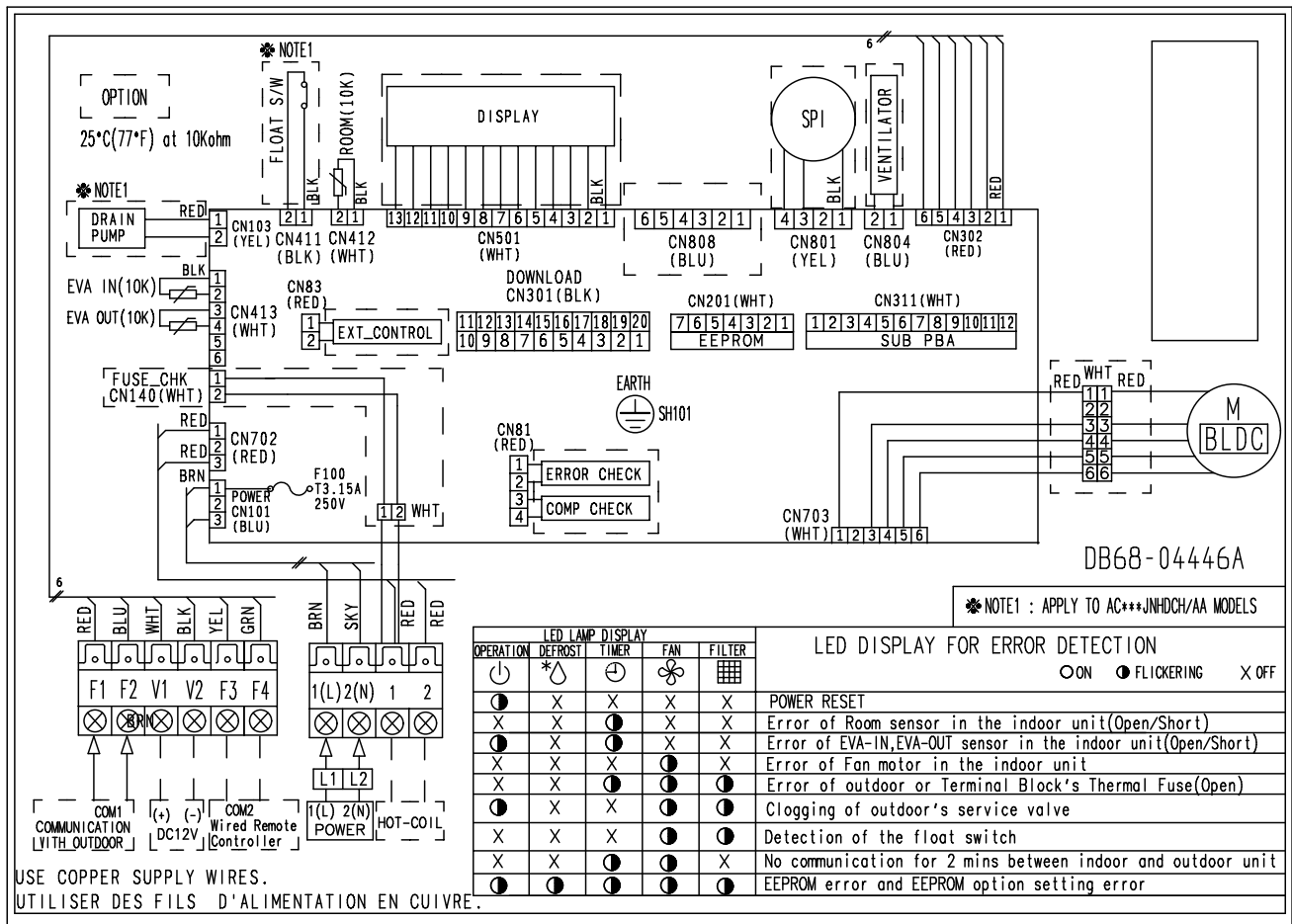

This Document can not be used without Samsung's authorization.

Indoor Unit (cont.)

■ Duct: AC035/052/071/100/120/140RNMDKG

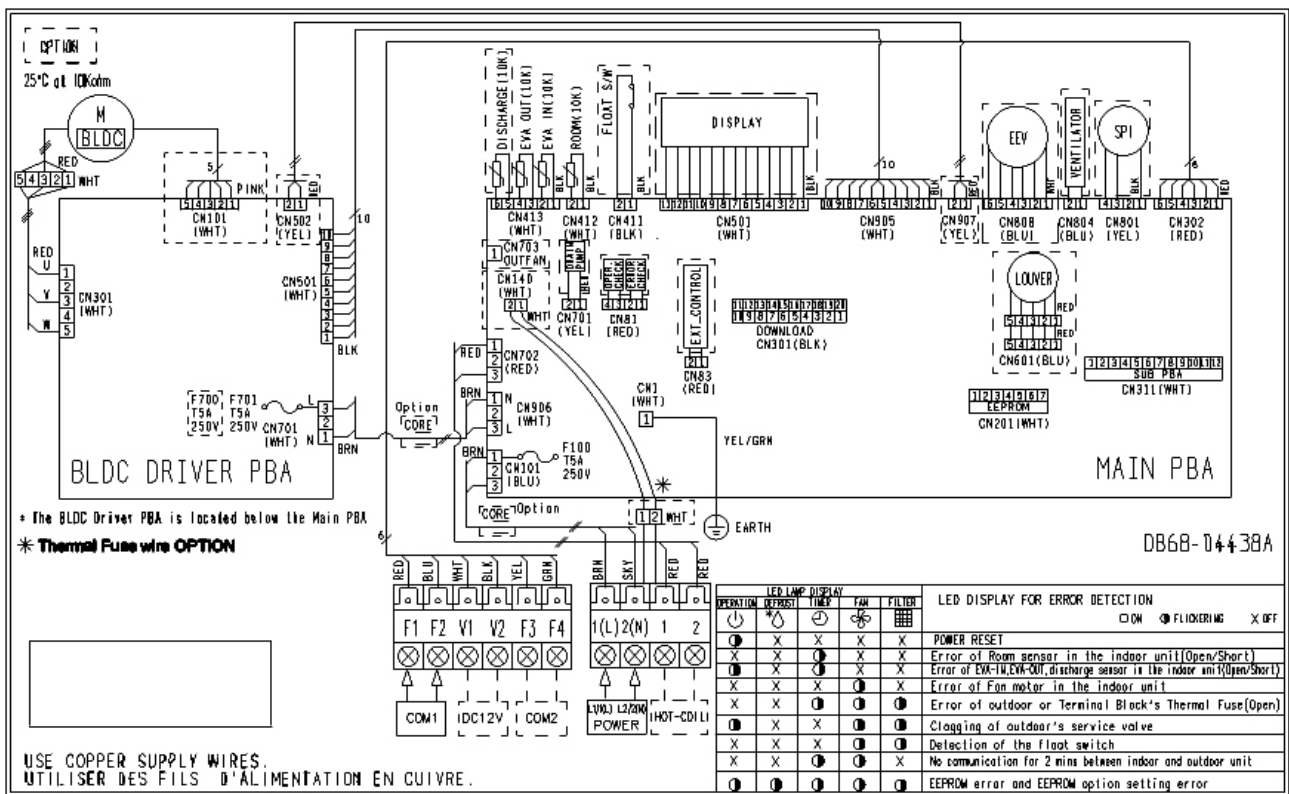

Indoor Unit (cont.)

■ C-RAC: AC026/035/052/071RNADKG, AC100RNTDKG

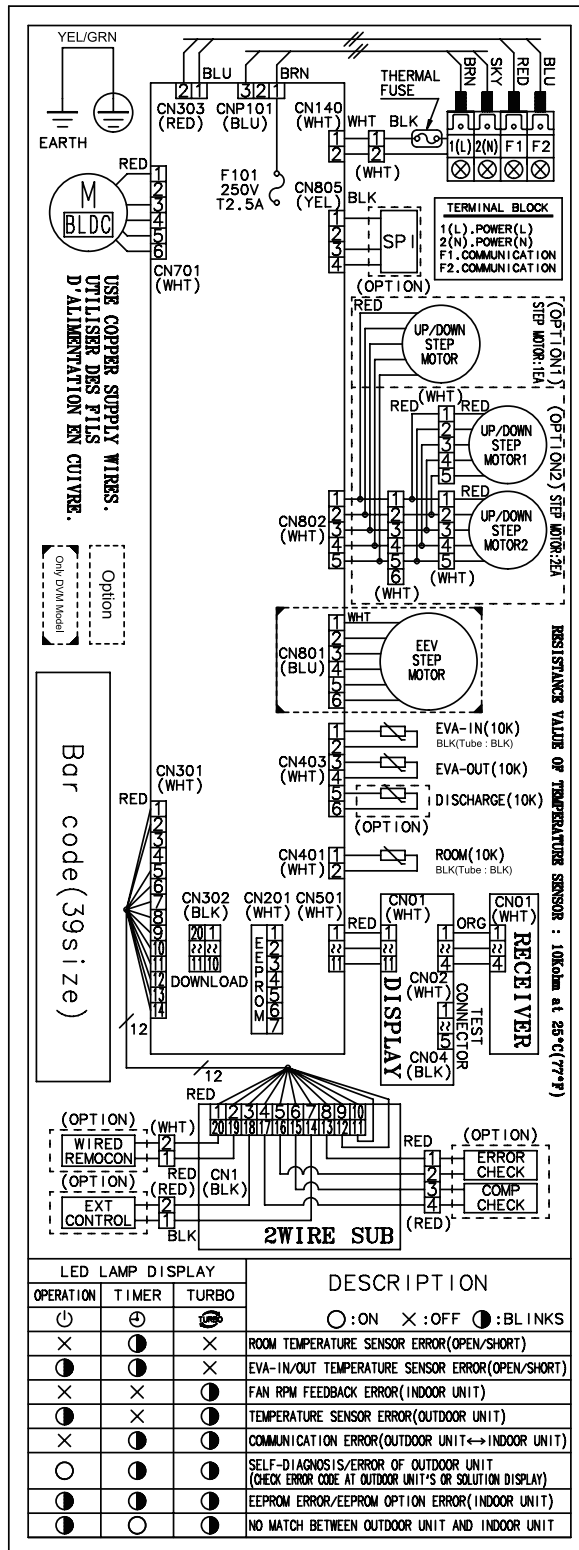

This Document can not be used without Samsung's authorization.

Indoor Unit (cont.)

■ Ceiling: AC052/071RNCDKG (cont.)

▶ Type B

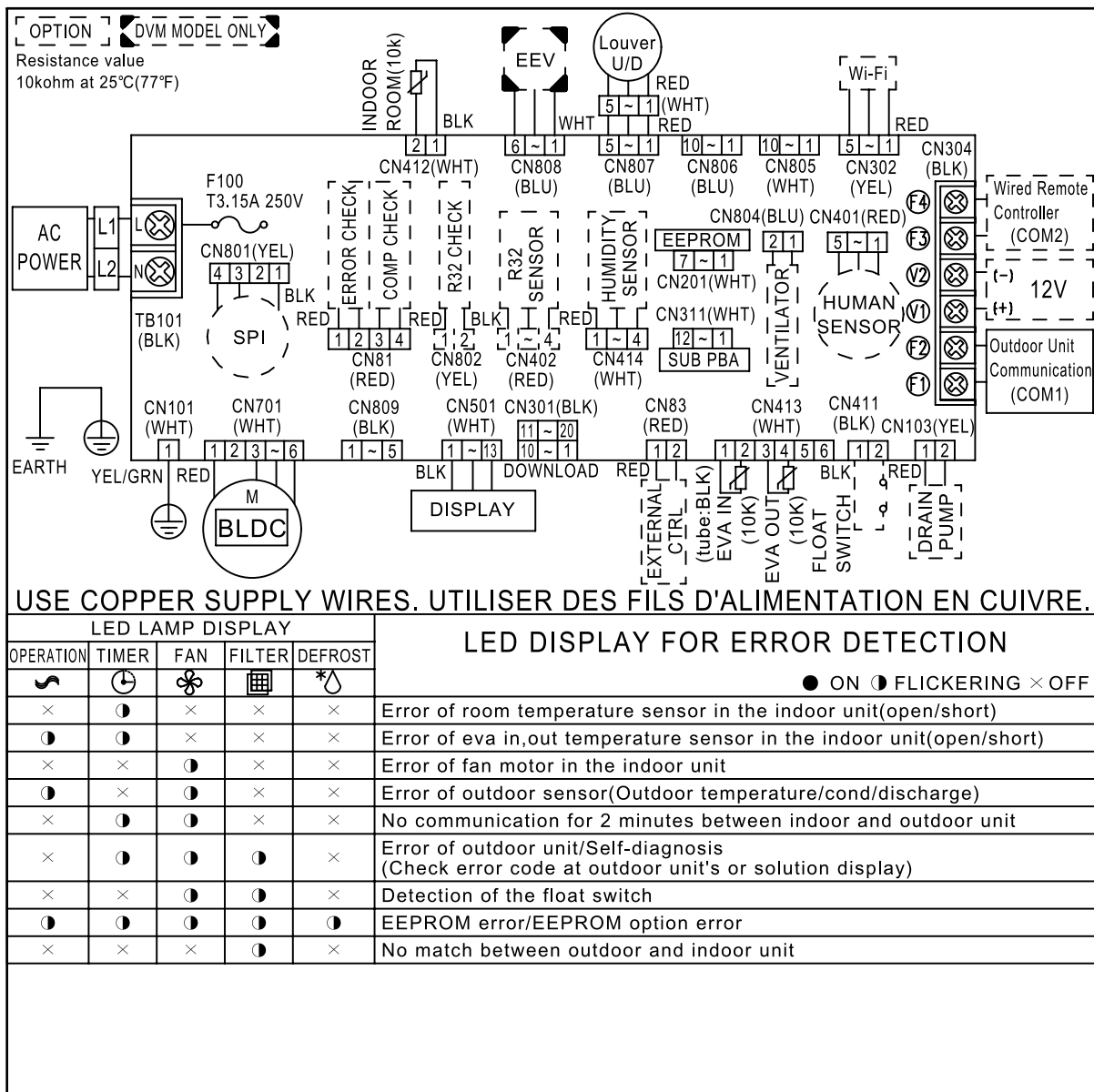

This Document can not be used without Samsung's authorization.

Indoor Unit (cont.)

■ Ceiling: AC100/120/140RNCDKG

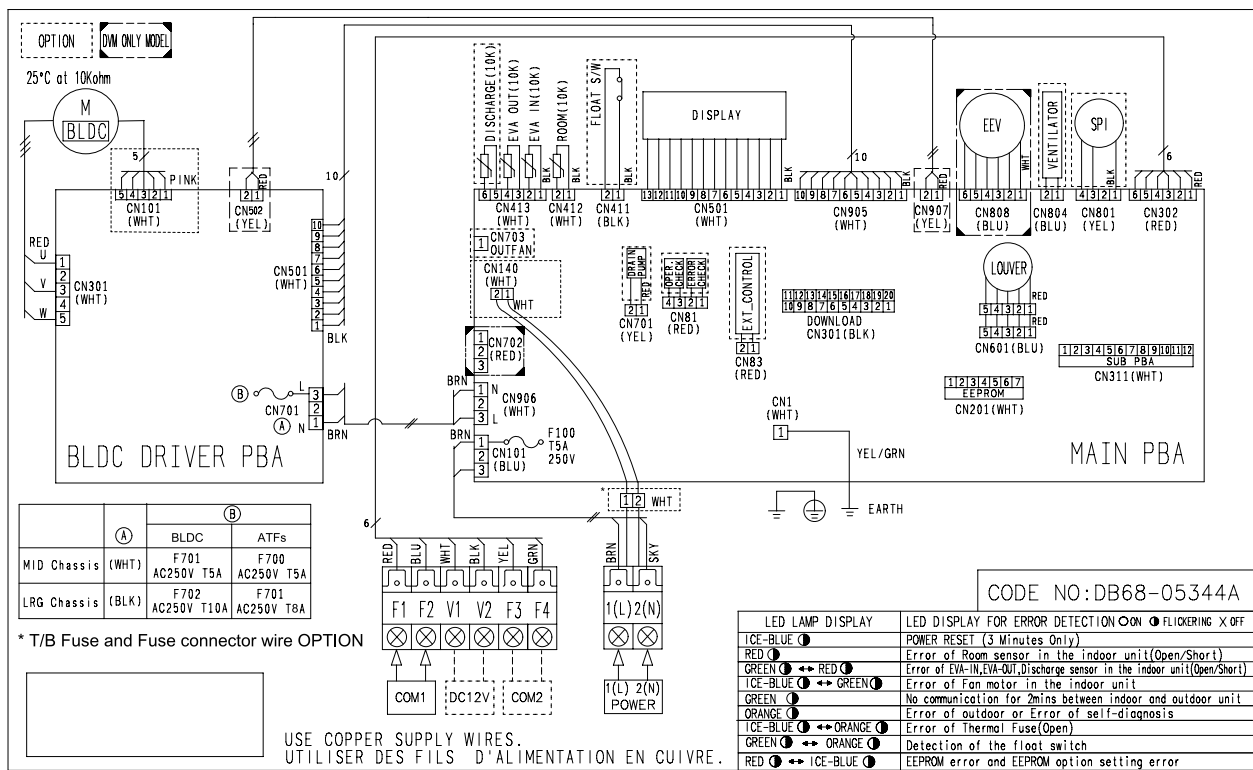

Indoor Unit (cont.)

- Console: AC026/035/052RNJDKG
- ▶ Type A

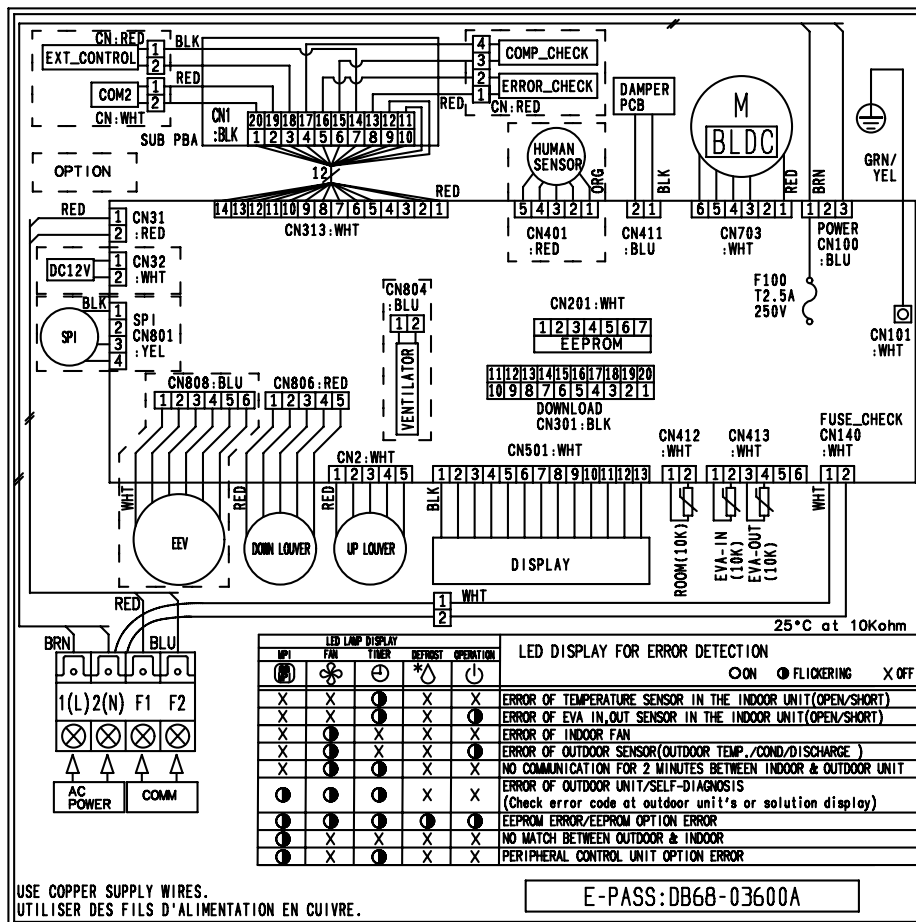

6-2 Outdoor unit

■ AC026/035RXADKG

▶ Type A

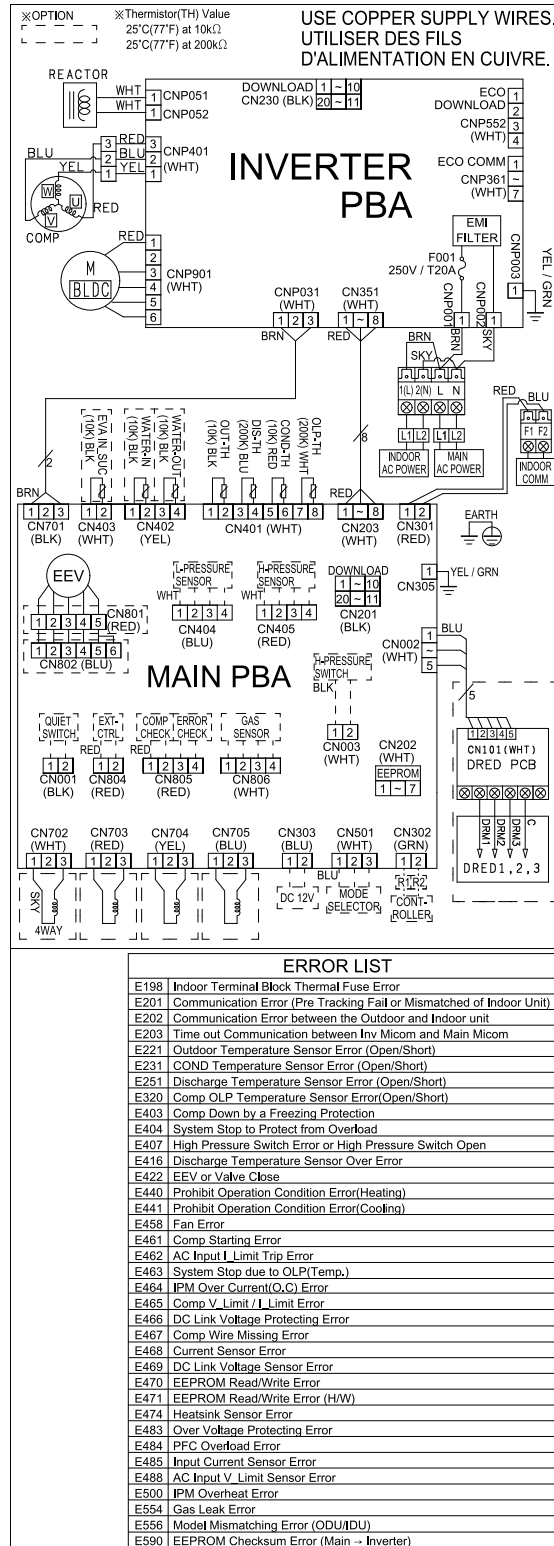

This Document can not be used without Samsung's authorization.

Indoor Unit (cont.)

■ AC026/035RXADKG (cont.)

▶ Type B

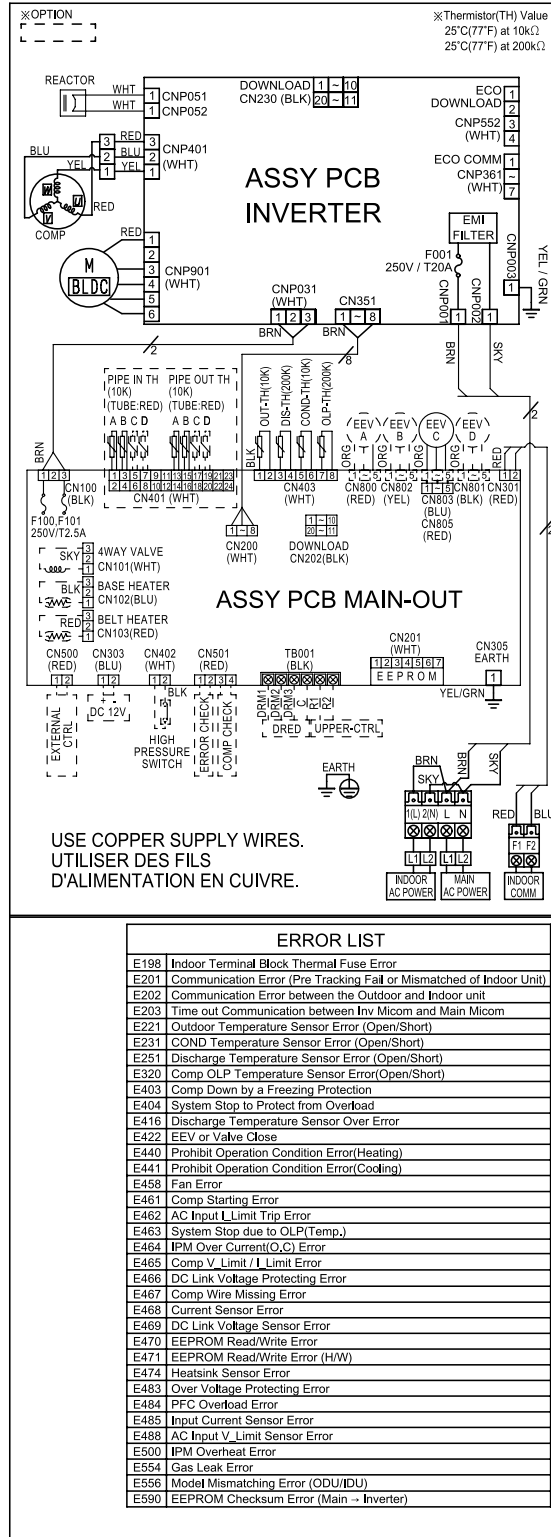

This Document can not be used without Samsung's authorization.

Outdoor unit (cont.)

■ AC052/071RXADKG

▶ Type A

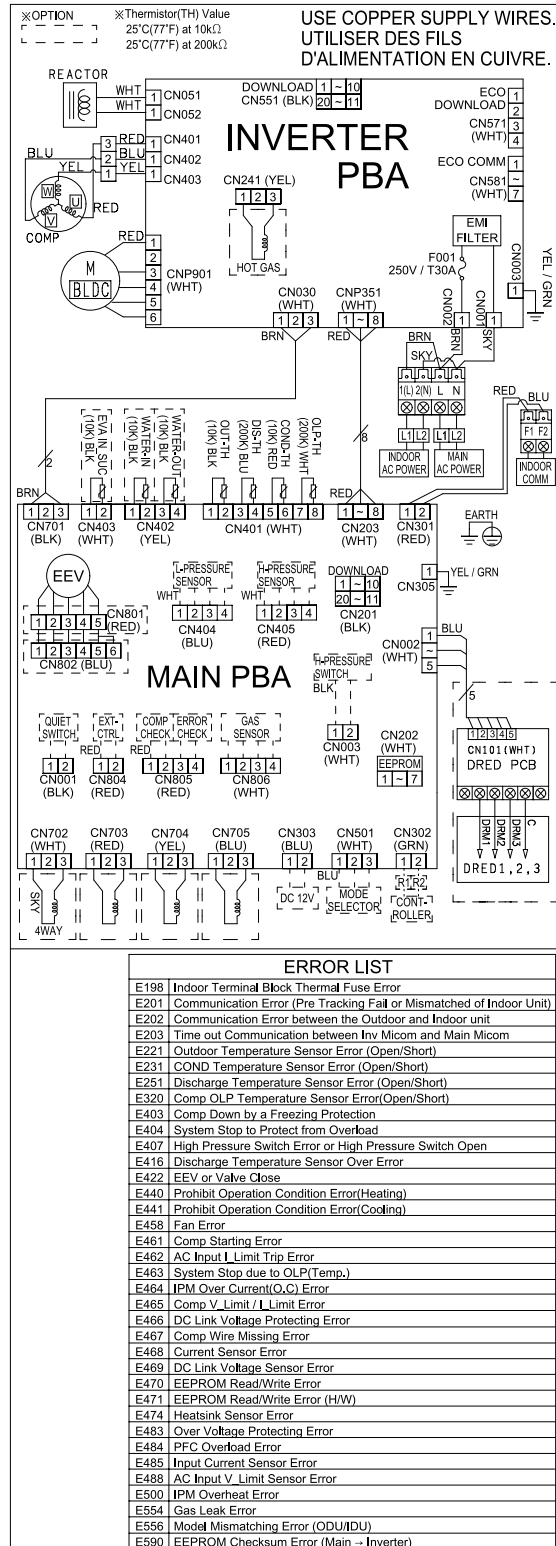

This Document can not be used without Samsung's authorization.

Indoor Unit (cont.)

■ AC052/071RXADKG (cont.)

▶ Type B

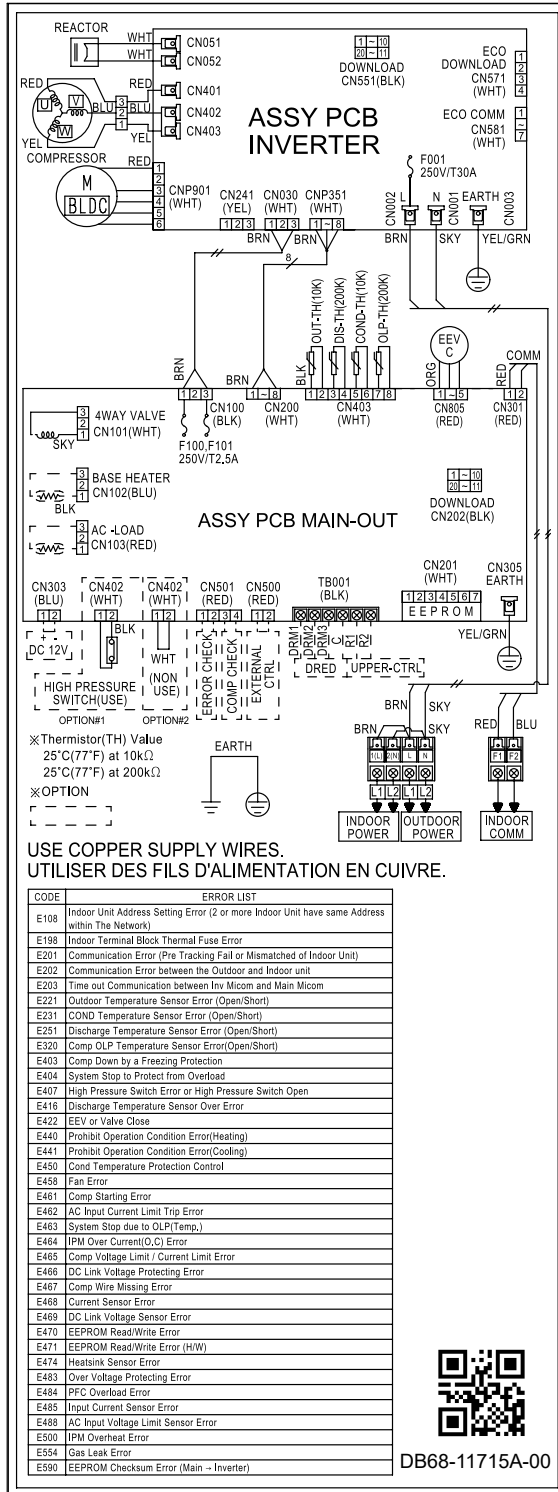

Outdoor unit (cont.)

■ AC100/120/140RXADKG ▶ Type A

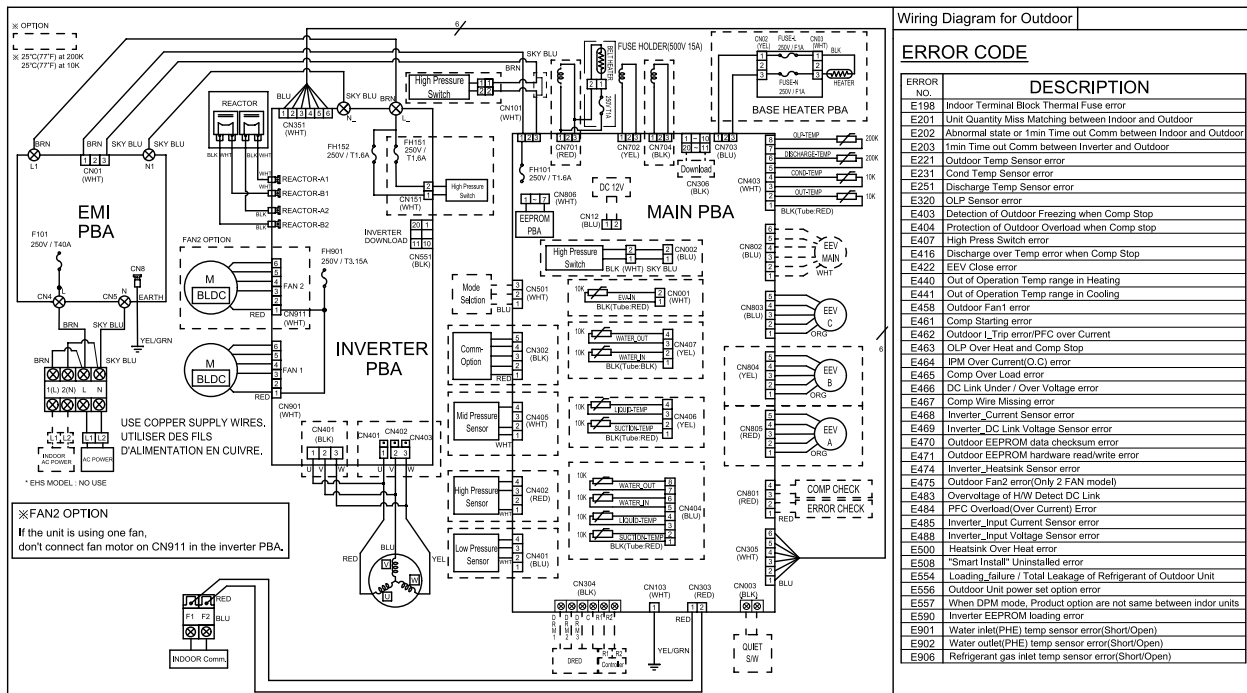

This Document can not be used without Samsung's authorization.

Indoor Unit (cont.)

■ AC100/120/140RXADKG (cont.)

▶ Type B

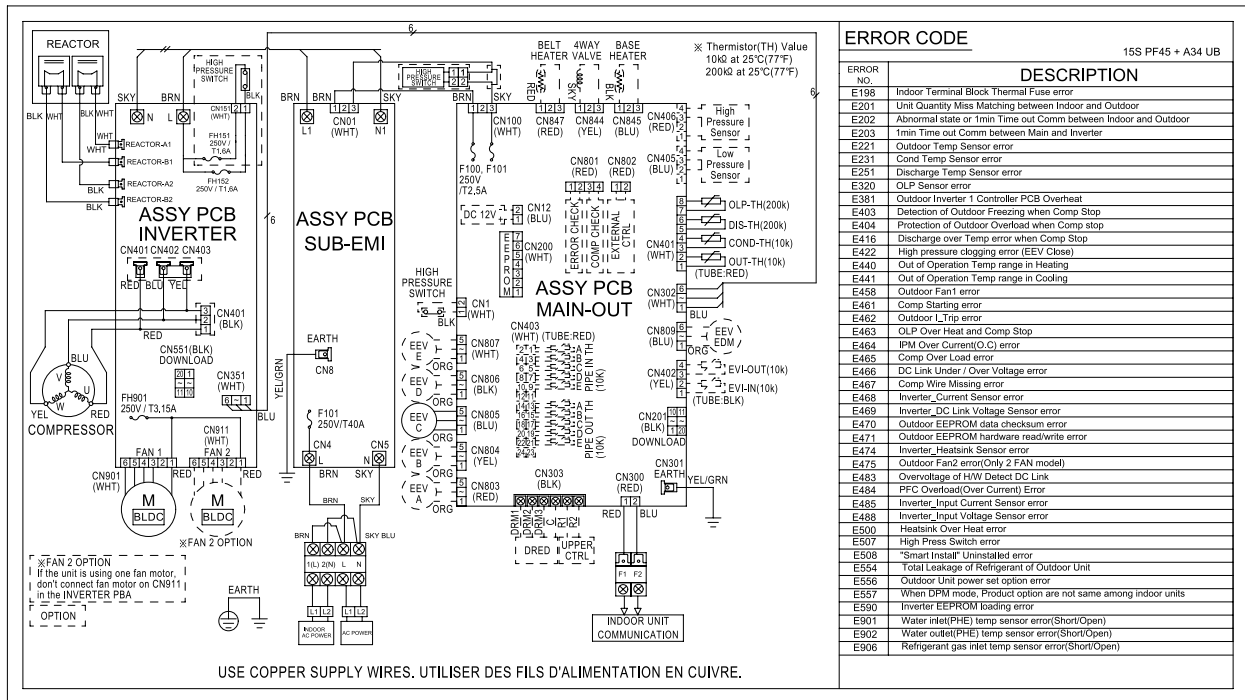

Outdoor unit (cont.)

- AC100/120/140RXADNG
- ▶ Type A

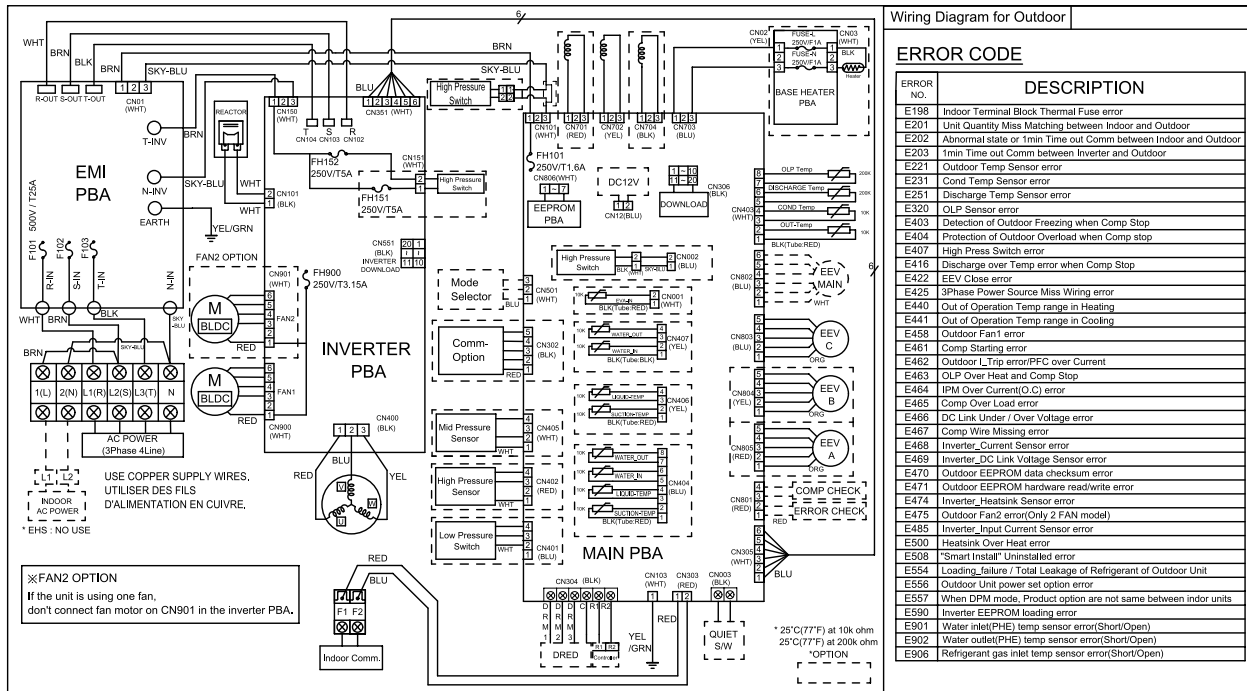

Wiring Diagram for Outdoor	
ERROR CODE	
ERROR NO.	DESCRIPTION
E198	Indoor Terminal Block Thermal Fuse error
E201	Unit Quantity Miss Matching between Indoor and Outdoor
E202	Abnormal state or 1min Time out Comm between Indoor and Outdoor
E203	1min Time out Comm between Inverter and Outdoor
E221	Outdoor Temp Sensor error
E231	Cond Temp Sensor error
E251	Discharge Temp Sensor error
E320	OLP Sensor error
E403	Detection of Outdoor Freezing when Comp Stop
E404	Protection of Outdoor Overload when Comp stop
E407	High Press Switch error
E416	Discharge over Temp error when Comp Stop
E422	EEV Close error
E425	3Phase Power Source Miss Wiring error
E440	Out of Operation Temp range in Heating
E441	Out of Operation Temp range in Cooling
E458	Outdoor Fan1 error
E461	Comp Starting error
E462	Outdoor L Trip error/FFC over Current
E463	OLP Over Heat and Comp Stop
E464	IPM Over Current(O.C) error
E465	Comp Over Load error
E466	DC Link Under / Over Voltage error
E467	Comp Wire Missing error
E468	Inverter Current Sensor error
E469	Inverter DC Link Voltage Sensor error
E470	Outdoor EEPROM data checksum error
E471	Outdoor EEPROM hardware read/write error
E474	Inverter Heatsink Sensor error
E475	Outdoor Fan2 error(Only 2 FAN model)
E485	Inverter Input Current Sensor error
E500	Heatsink Over Heat error
E508	"Smart Install" Uninstalled error
E554	Loading_failure / Total Leakage of Refrigerant of Outdoor Unit
E556	Outdoor Unit power set option error
E557	When DPM mode, Product option are not same between indoor units
E590	Inverter EEPROM loading error
E901	Water inlet(PHE) temp sensor error(Short/Open)
E902	Water outlet(PHE) temp sensor error(Short/Open)
E906	Refrigerant gas inlet temp sensor error(Short/Open)

This Document can not be used without Samsung's authorization.

Indoor Unit (cont.)

■ AC100/120/140RXADNG (cont.)

▶ Type B

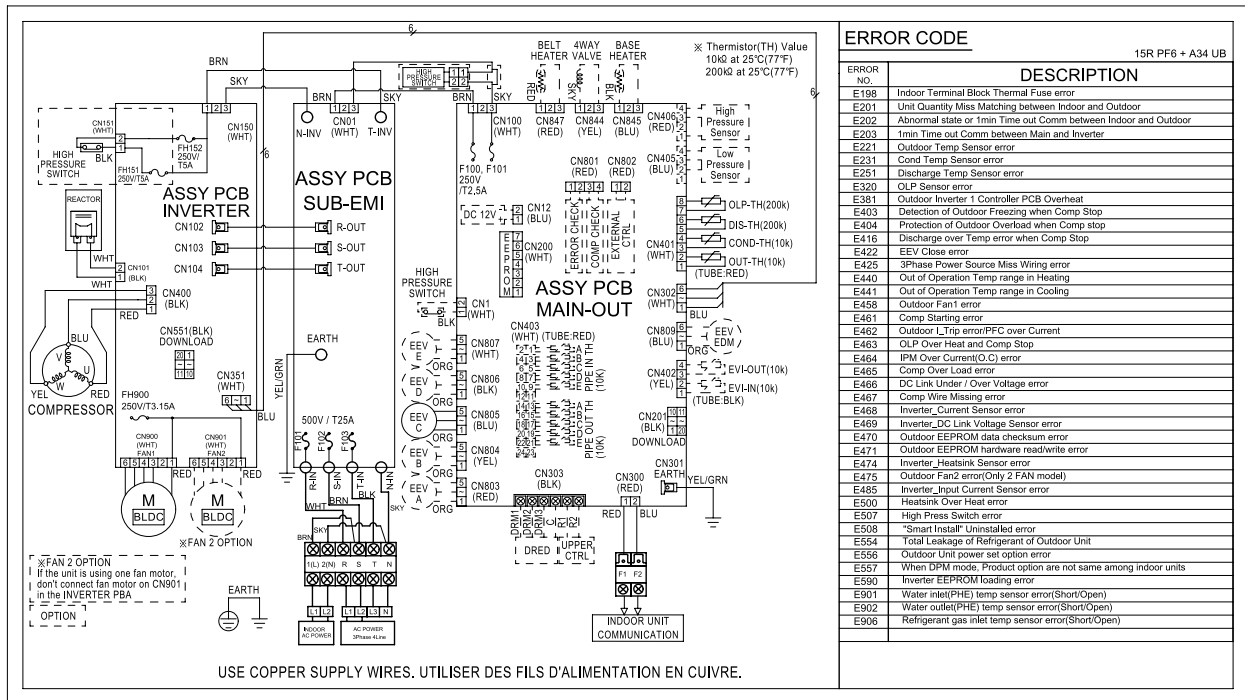

This Document can not be used without Samsung's authorization.

7. Reference Sheet

7-1 Index for Model Name

7-1-1 Indoor Unit

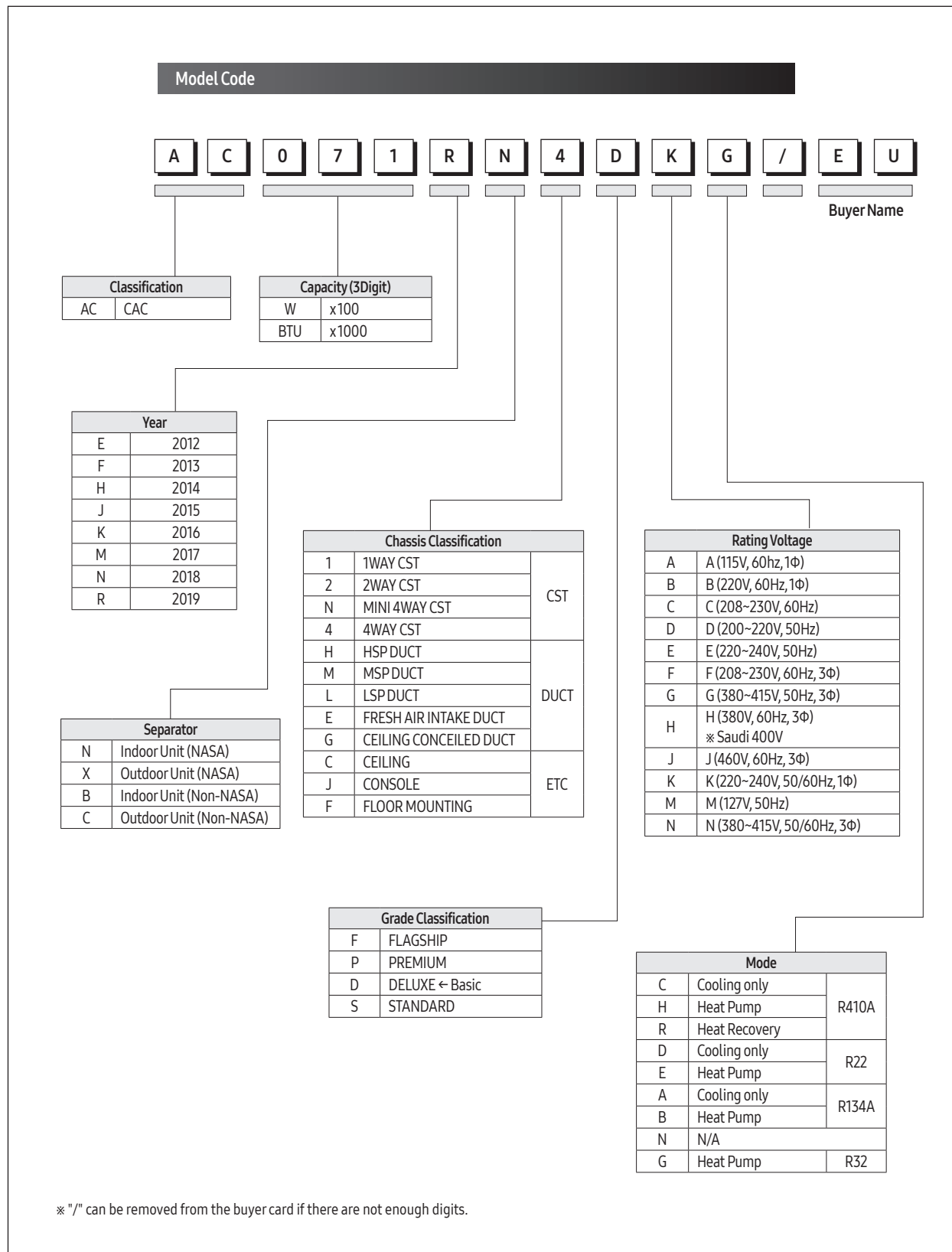

Index for Model Name (cont.)

7-1-2 Outdoor Unit

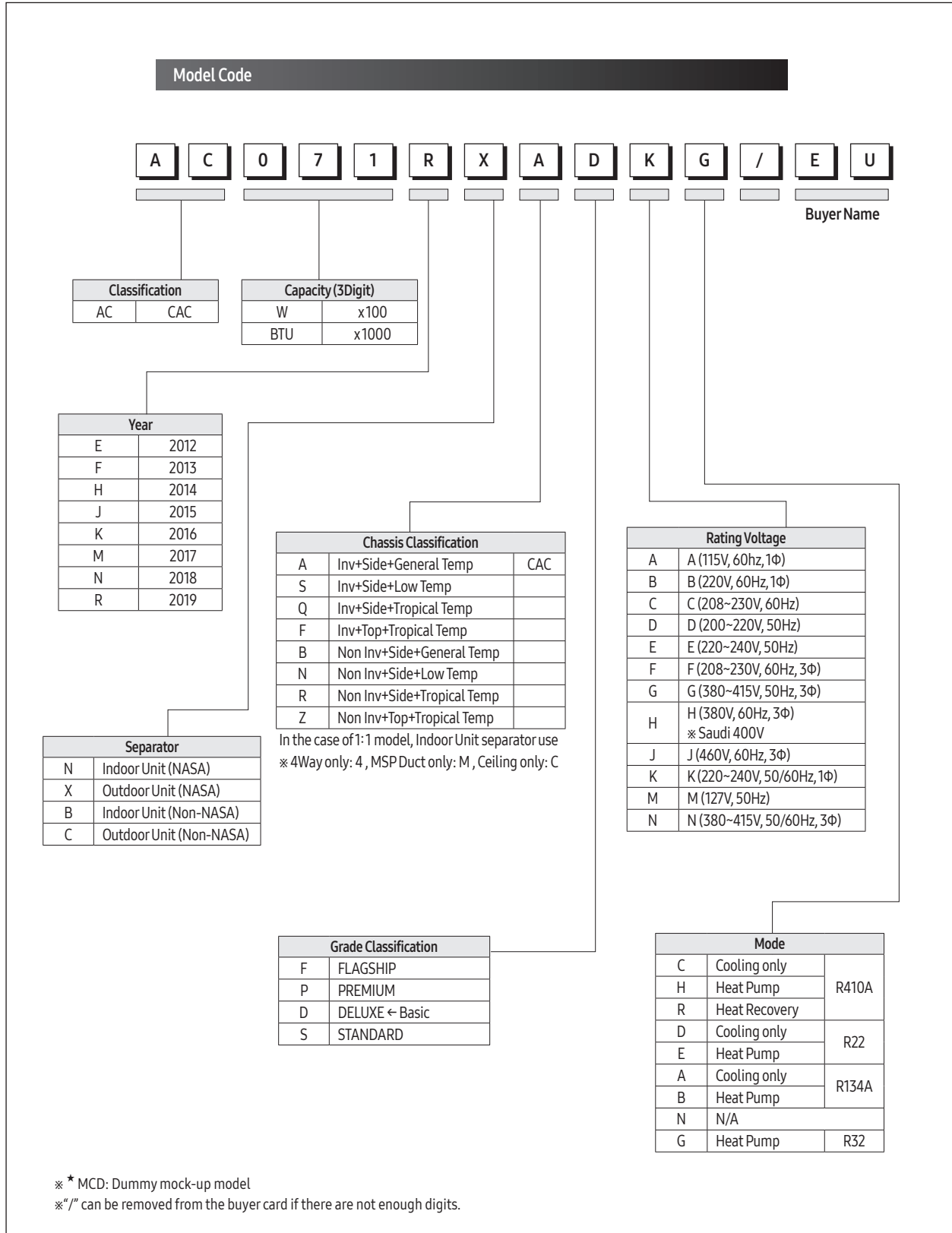

Index for Model Name (cont.)

7-1-3 Panel

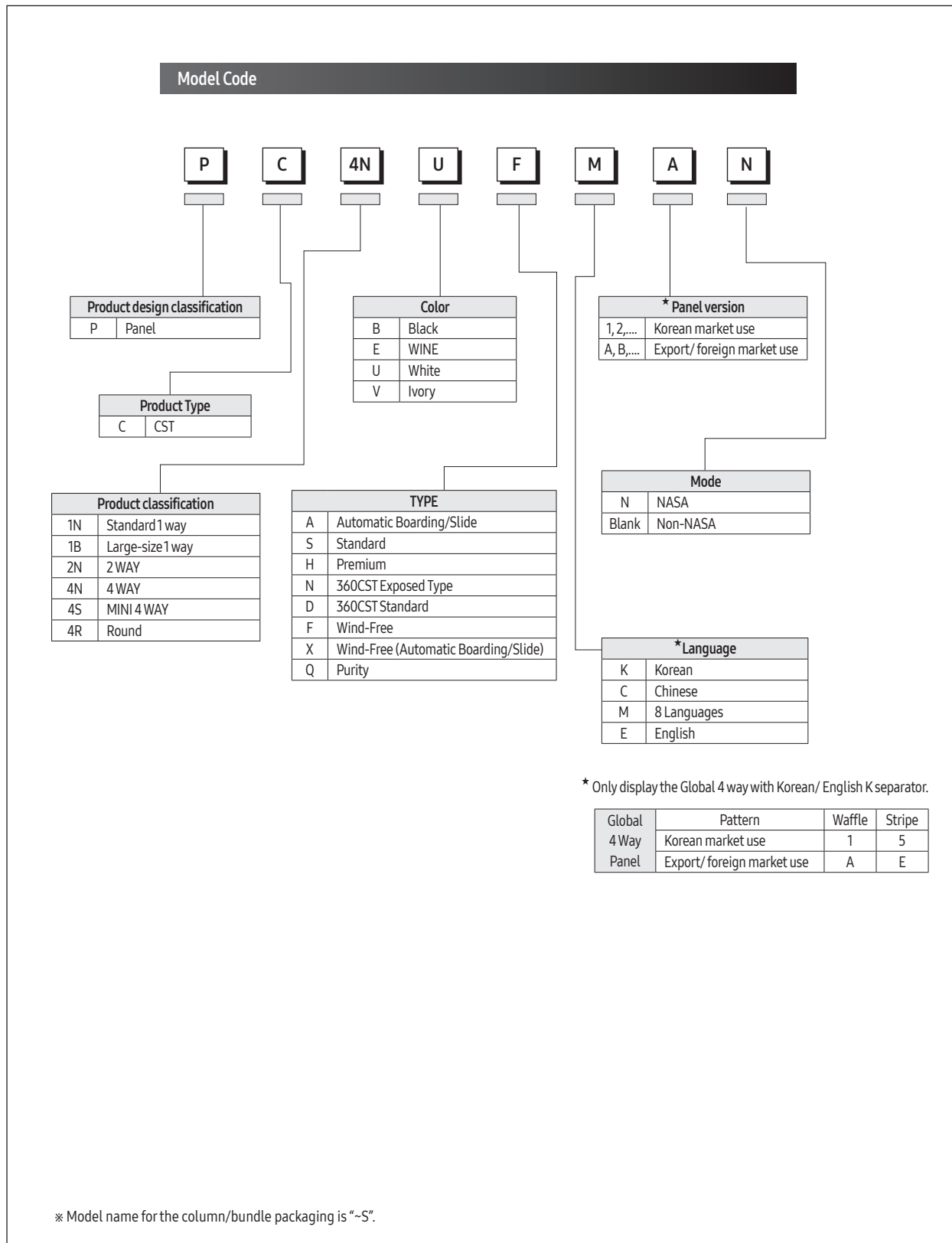

7-2 Refrigerating Cycle Diagram

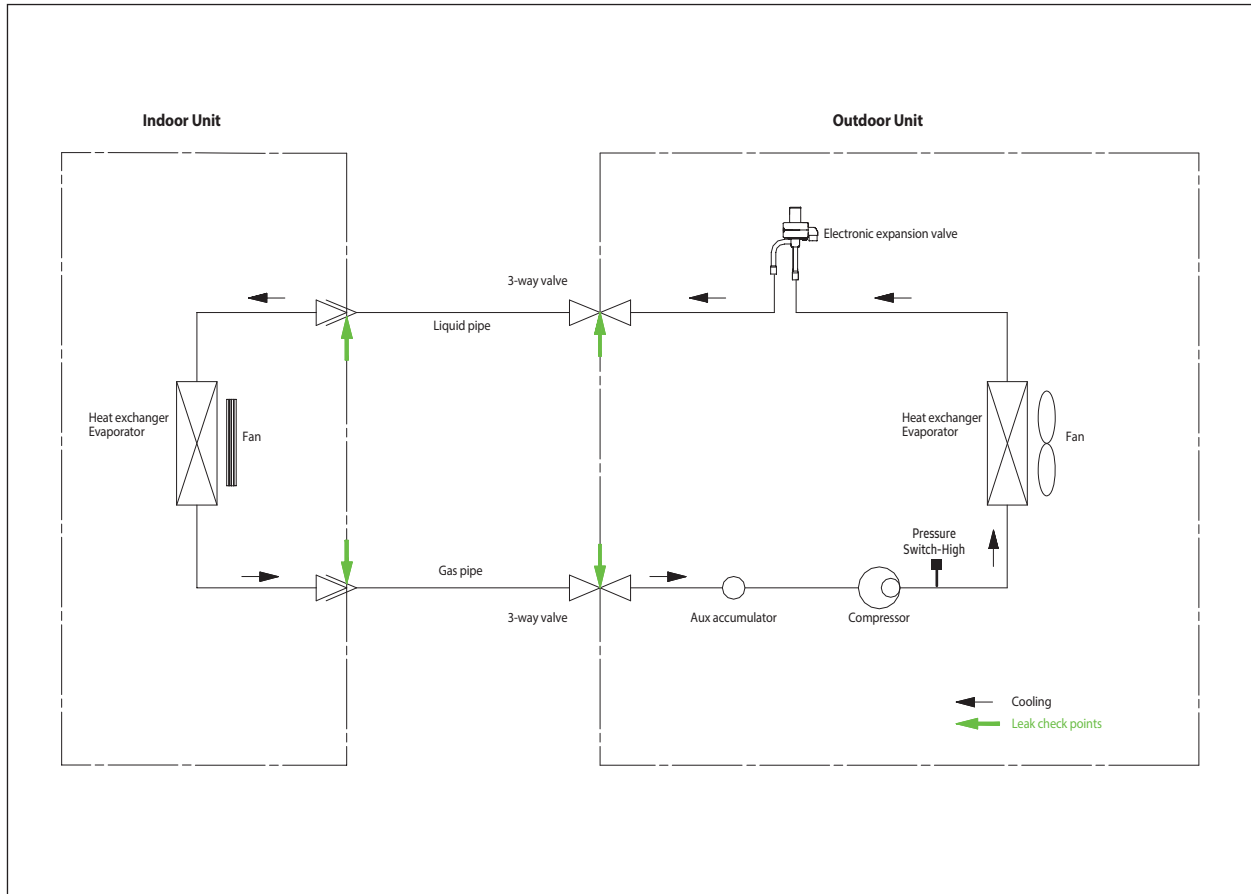

■ CONDENSER

High temperature and high pressure gas state refrigerant discharged from the compressor is converted to a liquid state as it is cooled down by the heat emission in the outdoor condenser unit, and sent to the evaporator.

■ COMPRESSOR

Low temperature and low pressure refrigerant is compressed and sent to the cycling system

■ EVAPORATOR

Liquid refrigerant sucked in through the capillary tubes cools down the room by absorbing the surrounding heat as it evaporates (converting from liquid to gas). (Absorbing heat required for evaporation)

■ SERVICE VALVE

You can open the valve by turning the need valve counterclockwise using hex wrench, and it is used for vacuum, gas purging, refrigerant injection, refrigerant purging, and indoor-outdoor unit connection.

■ ACCUMULATOR

Accumulator prevents the flow of liquid-state refrigerant into the compressor. (Liquid-state refrigerant flowing into the compressor will overload the compressor.)

SAMSUNG

GSPN (GLOBAL SERVICE PARTNER NETWORK)

Area	Web Site
Europe, CIS, Mideast & Africa	gspn1.samsungcsportal.com
Asia	gspn2.samsungcsportal.com
North & Latin America	gspn3.samsungcsportal.com
China	china.samsungportal.com

This Service Manual is a property of Samsung Electronics Co., Ltd.
Any unauthorized use of Manual can be punished under applicable
International and/or domestic law.

© Samsung Electronics Co., Ltd. August. 2025.
Printed in Korea.
Code No. AC-00232E_1